

GDS TPMS

USER'S GUIDE

CONTENTS

CHECK BEFORE USE	3
CHECK BEFORE USE	4
CAUTIONS AT USING	5
SPECIFICATION	10
COMPONENT	11
BASIC USAGE	12
DESCRIPTION FOR BODY	13
POWER ON/OFF & EXT. POWER SUPPLY	15
GDS TPMS SELF-DIAGNOSIS SYSTEM CONNECTION	17
TPMS DIAGNOSIS	19
INTRODUCTION FOR TPMS DIAGNOSIS MODE	20
ID REGISTER	22
DATA TREATMENT	31
APPENDIX	38
USER MAINTENANCE	39
GDS TPMS AND PERIPHERALS LIMITED WARRANTY	43
DISPOSAL OF OLD ELECTRICAL AND ELECTRONIC EQUIPMENT	45

Check before Use

- Check before Use ----- A-10-001
- Cautions at Using ----- A-10-002
- Specification ----- A-10-003



Check before Use



1. Introduction

Thank you for purchasing TPMS (Tire Pressure Monitoring System) of G.I.T which is the diagnosing equipment of GDS.

GDS TPMS, as the optional equipment of GDS diagnosing system of GDS, is the specific equipment for diagnosing the TPMS (Tire Pressure Monitoring System) installed at vehicle. Using GDS TPMS, you can diagnose the TPMS of your vehicle easily. Further, when system specification is changed (at replacing TPMS sensor, replacing TPMS control module), the changed specification can be registered by simply operation.

2. Configuration of Manual

This manual describes the basic items required for using the GDS TPMS module, mainly. Please refer to the GDS User's Manual for the guide for using GDS S/W and the same contents with the conventional GDS diagnosing functions.

Check before use	<ul style="list-style-type: none"> ● GDS TPMS configuration and characteristics, Cautions at using.
Basic usage	<ul style="list-style-type: none"> ● Description for basic usage of GDS TPMS
TPMS Diagnosis	<ul style="list-style-type: none"> ● Description for the functional manual relating to TPMS in the Vehicle S/W Management of GDS
APPENDIX	<ul style="list-style-type: none"> ● User Maintenance and How to install driver ● Description for disposal of used equipment and for limited warranty

3. Checking Items

GDS TPMS module is delicately structured electric equipment. Before using this product, you should check the cautions. G.I.T does not have any reliability for the damages caused by user's carelessness.

This chapter includes warnings and noticing sentences which user should read and be familiar with them before using the GDS TPMS module.

	<p>WARNING</p> <p>This indicates incorrect handling may result in a major accident involving death or serious injury.</p>
---	--

- ☞ All cables for GDS TPMS function should be connected correctly. During working functions, any cable should not be disconnected.
- ☞ When CABLE-BATTERY (P/No: GSTA-37210A) is connected to the vehicle battery, check if the polarity of battery terminal is correctly connected.
- ☞ Do not disassemble the GDS TPMS module. For maintenance, follow the instructions describing in the manual.
- ☞ When updating the GDS TPMS module, connect the external power supply (AC/DC adaptor) to supply the stable power.
- ☞ When using the AC/DC adaptor as the external power supply, adapter satisfying the specification regulated by GIT should be used.
- ☞ The accessory parts relating to the GDS TPMS should be authorized product by supplied by GIT.

- ☞ Use this equipment under the properly regulated temperature condition (Refer to specification)
- ☞ The equipment should be stored under the properly regulated temperature condition. (Refer to specification)
- ☞ This equipment should be only used for purpose regulated by GIT.
- ☞ Before using this equipment, you should be familiar with the manual enough.
- ☞ For the damages caused by user's carelessness and by that user does not comply with the cautions and warnings, it is reliable to user..
- ☞ The GIT product should be diagnosed or repaired by service manpower authorized by GIT.
- ☞ When exchanging rechargeable battery, you should read the manual and be familiar with the instructions.
- ☞ Use the only rechargeable battery supplied from the GIT.
- ☞ Do not disconnect the rechargeable battery arbitrarily.
- ☞ Do not sink the rechargeable battery into the water or wet it.
- ☞ Do not let the rechargeable battery near the fire.
- ☞ Do not impact the rechargeable battery and prick it with sharp object.
- ☞ Do not put it the rechargeable battery into microwave oven or high pressured container.
- ☞ Do not apply physical impact to the rechargeable battery.

- ☞ Be careful that the rechargeable battery is shorted.

- ☞ If any abnormal phenomena such as odor, heat, deformation or discoloration is appeared, do not use the rechargeable battery.

- ☞ Do not change the polarity of terminals.

- ☞ GIT has not any responsibility to any product except one supplied from GIT.

- ☞ Do not directly connect the rechargeable battery to the external power supply.

- ☞ Do not leave the rechargeable battery near the fire.

- ☞ Be careful that the anode (+) and cathode (-) terminals of the rechargeable battery are not shorted.

- ☞ The rechargeable battery is a consumable product so that it is not included into the warranty range of main product.

- ☞ For the warranty for the rechargeable battery and other expendables, please refer to the Warranty for Expenditures and Accessories of the warranty.

- ☞ If the rechargeable battery is damaged or deformed by user's carelessness, it cannot be repaired free of charge.

- ☞ The lifetime of rechargeable battery is different according to the using environment.



CAUTION

This indicates incorrect handling may lead to injury or damage to properties. Under certain conditions more serious consequences may result.

- ☞ Be careful that do not drop down the equipment.

- ☞ Do not put any goods on the GDS TPMS equipment.

- ☞ When connecting to the external power supply form the battery in the engine room, be careful that the connection line do not damaged by the heat from the engine room or driving part.

- ☞ When connecting the external power supply, check if the polarity is correct.

- ☞ All components should be restored in the appointed position when they are not using.

- ☞ Do not use the cable connected to the equipment as a handle.

- ☞ Do not store under the following environment.
 - High temperature or low temperature (refer to the specification)
 - High humidity or low humidity (refer to the specification)
 - Under the direct sunlight

- ☞ Do not put any heavy object on the equipment, do not apply any impact or do not shake it.

- ☞ During delivering product, do not apply any impact or shake it.

- ☞ Do not leave it near the object which can make fire by electric flames.

- ☞ Be careful that the main body and accessories of TPMS module do not contaminated by paint, chemical pigment, or acid material. It may cause corrosion of product.

- ☞ Do not expose the product to the X-ray or Microwave. It may cause serious damages on the product.

- ☞ Do not store the battery at the hot place. It may reduce the battery lifetime.

- ☞ When storing the GDS TPMS equipped with battery for a long time (3 months or more), comply with the storing instruction (temperature: $23\pm 5^{\circ}\text{C}$, humidity: $65\pm 20\%RH$).

- ☞ If your eyes are contacting with the liquid of battery, do not rub your eyes but clean with flowing water and then contact doctor.



SPECIFICATION



Check before use

Module: A-10-003

Item		Specifications
Micro Controller		8Bit MCU (MB95F136) @4MHz
Operating Voltage		7~35V DC
Communication Port Specification		RS 232, 9600 bps
TPMS LF/RF		LF: 125 kHz RF: 315MHz or 433MHz
TPMS Protocol		SIEMENS (FSK)
Rechargeable Battery		Li-Ion Polymer 2100mAh 1cell
Temperature	Operating	0°C~45°C (32°F~113°F) : Battery Charging -10°C~50°C (14°F~122°F) : Battery Discharging
	Storing	-10°C~70°C (14°F~158°F) (Refer to cautions of manual)
Relative Humidity	Operating	Noncondensing @ 0°C~10°C (32°F~50°F)
		90%RH @ 10°C~30°C (50°F~86°F) 70%RH @ 30°C~50°C (86°F~122°F)
	Storing	Noncondensing @ -10°C~70°C (14°F~158°F) (Refer to cautions of manual)
Ex Lamp	POWER	RED
	CHARGE	RED, GREEN
	LF/RF LED	RED, GREEN
Button		Power ON/OFF Key, Enter Key
Module Size		127 X 86 X 36 mm
Weight		255 g
Case		PC+ ABS
Shroud		TPE







COMPONENT

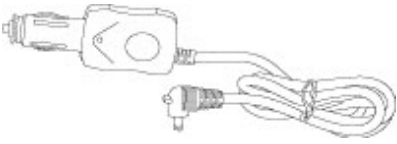

Check before use

Module: A-10-004

Part	Description	Qty.
<p>GDS TPMS Module</p> 	<p>P/No: G1TDDMN001</p> <p>This is the module for communicating directly using the wireless signal (RF/LF) with TPMS sensor installed at the tire for diagnosing the TPMS of vehicle.</p>	<p>1</p>
<p>CABLE-[D-SUB 9P]</p> 	<p>P/No: G1TDDCA002</p> <p>This is the cable for communicating PC having GDS S/W with the GDS TPMS module.</p>	<p>1</p>
<p>CABLE-CIGAR</p> 	<p>P/No: G1PDDCA002</p> <p>This is the cable for supplying the external power to the GDS TPMS module using the cigar lighter terminal.</p>	<p>1</p>
<p>CABLE-BATTERY</p> 	<p>P/No: GSTA-37210A</p> <p>This is the cable for supplying external power to the GDS TPMS module directly from the battery in the vehicle by connecting to the Cable - Cigar (P/No: G1PDDCA002).</p>	<p>1</p>
<p>CABLE-USB to RS232C CONVERTER</p> 	<p>P/No: G1TDDCA001</p> <p>This is the converter for changing the RS232 type connector to USB type in order to use USB port when PC has not RS232 port at connecting GDS TPMS module to the PC having GDS S/W.</p>	<p>1</p>

Basic Usage

- Description for Body ----- A-11-001
- Power ON/OFF and External Power Supply ----- A-11-002
- GDS TPMS Self-Diagnosis System Connection ----- A-11-003



<Figure 1. TPMS Diagnosing Module>

	Item	Function
①	POWER Button	Button for ON/OFF the power of TPMS module.
②	ENTER Button	Button for detecting diagnosing data and ID through the RF communication with TPMS sensor installed at the vehicle tire.
③	POWER LED	Showing the power condition of current GDS TPMS equipment.
④	LF/RF LED	Turning on at communicating with TPMS installed at the tire of vehicle.
⑤	CHARGE LED	Turning on at connecting the external power and showing the battery charging condition.

Body LED Turn-ON Condition

1) POWER LED Turn-ON Condition

		LED Status
Power	ON	RED
	OFF	OFF
Battery Voltage Low		RED Blinking

2) CHARGE LED

	LED Status
Full Charged	GREEN
Discharging	OFF
Charging	RED

3) LF/RF LED

	LED Status
LF sending	RED
RF receiving	GREEN Blinking
Waiting	OFF



1. Power ON

Press the POWER button of GDS TPMS module body for about 0.5 seconds or more until the red light is shown on the POWER LED.

2. Power OFF

Press the POWER button of GDS TPMS module body for about 1.5 seconds or more.

3. How to connect the External power

- Using CABLE-CIGAR (P/No: G1PDDCA002), power is supplied from the cigar lighter terminal of vehicle.
- Connecting CABLE-BATTERY P/No: GSTA-37210A) to CABLE-CIGAR (P/No: G1PDDCA002), power is supplied from the battery of vehicle directly.
- Power is supplied using the AC/DC adapter supplied with GDS.

NOTE:

- 👉 GDS TPMS module is designed so as it driven by the embedded rechargeable battery only.
- 👉 When battery is completely discharged, recharge it for 5 minutes or more after that the power can be ON.



Warning

- ☞ In order to prevent electric shock accident and to protect the equipment at supplying external power to TPMS module, use only the authorized power supplying method in the manual.
- ☞ Be careful that the power supplying cable does not contact to the driving part of the vehicle at supplying the external power to the TPMS module.

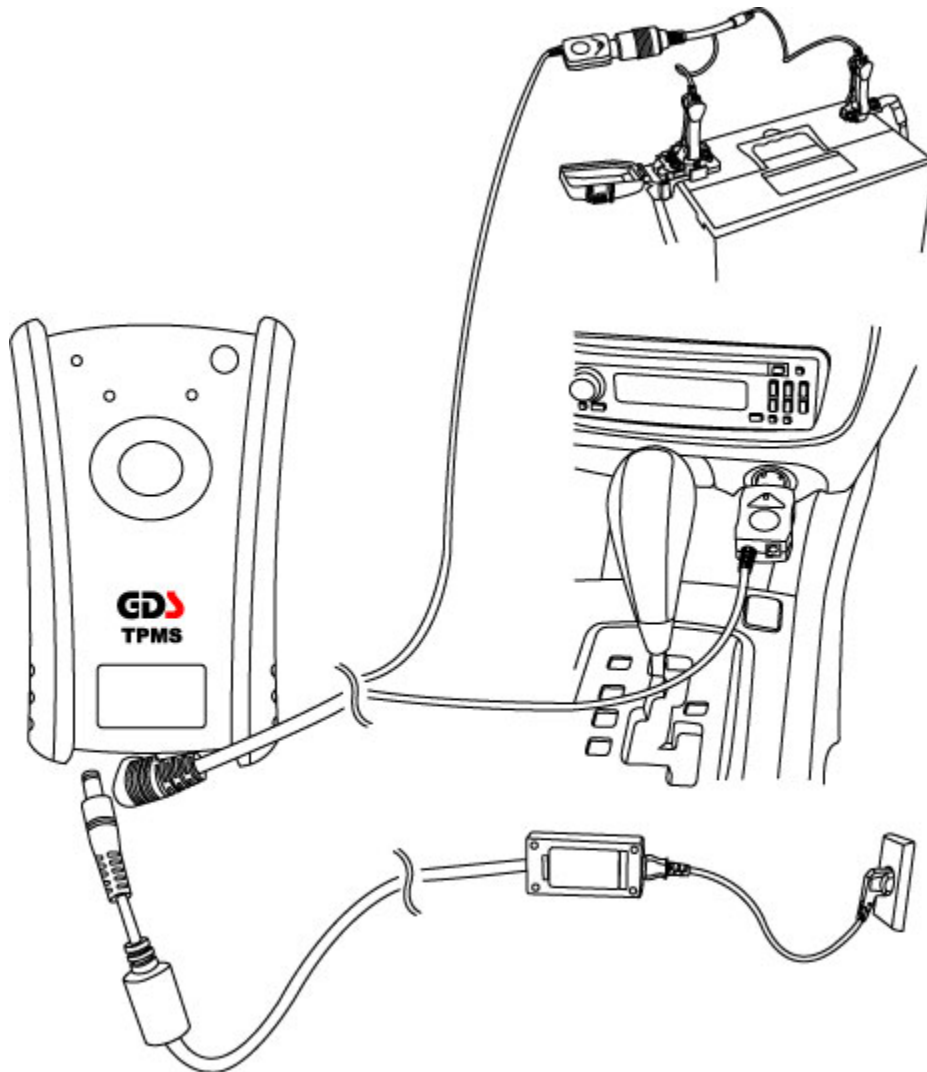

<Figure 1. TPMS module Ext. Power Connection>

For diagnosing the TPMS system, the diagnosing system should be configured and connected as following description.

1. GDS TPMS Diagnosis System Configuration

GDS VCI should be communicating with the vehicle through the DLC cable.

The PC having GDS Software should be communicating with GDS TPMS module through the RS 232 cable.

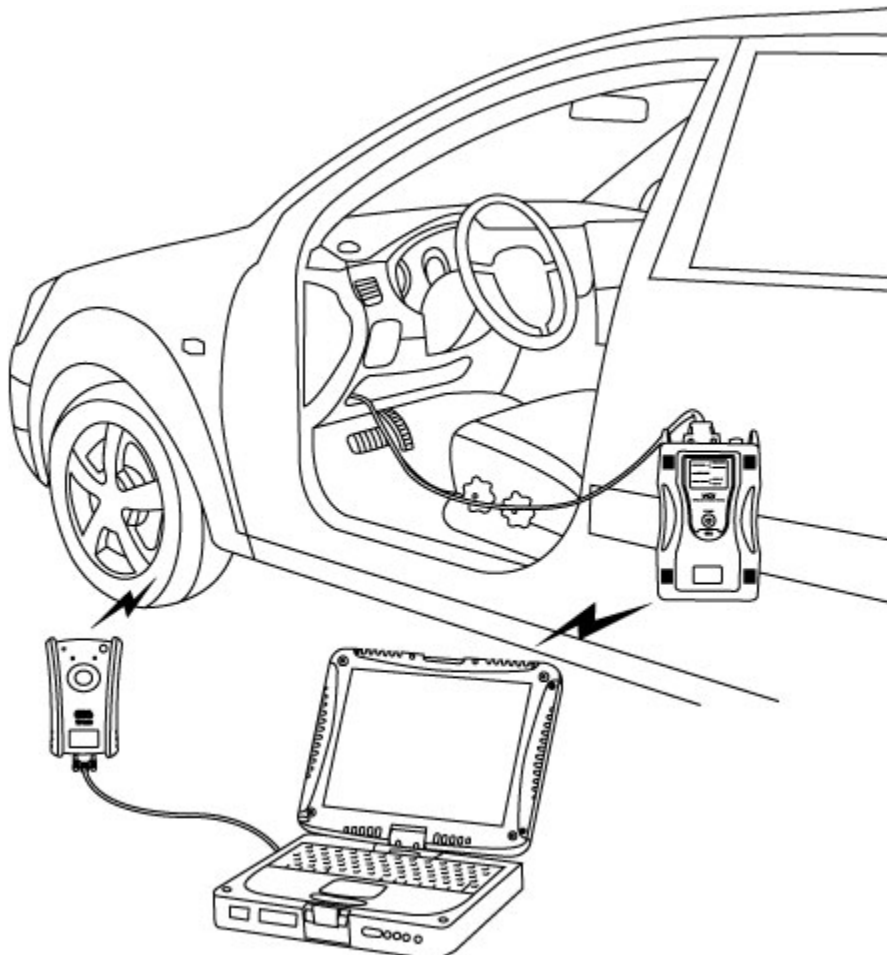

<Figure 1. GDS TPMS Connection>

Note:

If the PC having GDS S/W is not equipped with RS 232 port, connect them using CABLE-USB to RS232C CONVERTER (G1TDDCA001).

To use the USB to RS 232 CONVERTER (G1TDDCA001), the driver of the USB to RS 232 CONVERTER should be installed in the PC.

The USB to RS 232 converter driver is supplied with the product. At installing the driver, the USB to RS 232 CONVERTER is not connected to the PC.

TPMS DIAGNOSIS

- Introduction for TPMS Diagnosis Mode A-12-001
- ID Register A-12-002
- Data Treatment A-12-003

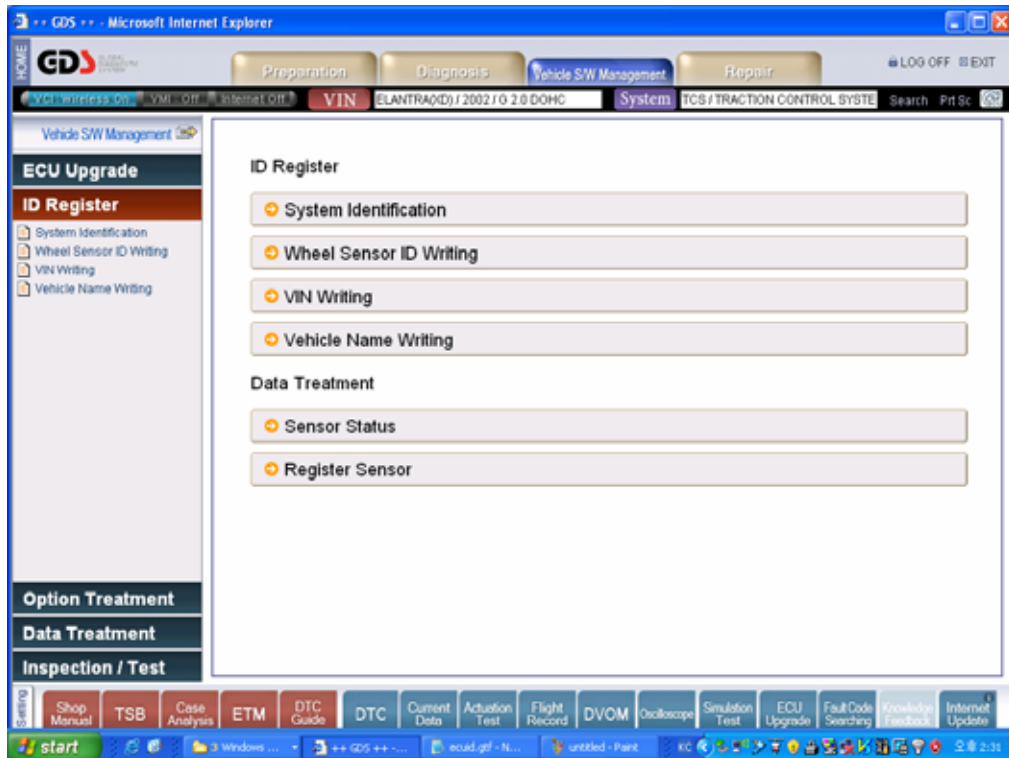

<Figure1. TPMS Screen>

1. ID Register

This is the function which can represent through the VCI.

System Identification	Function for confirming the detail information of the TPMS diagnosing vehicle and control module.
Wheel Sensor ID Writing	Function for inputting the each TPMS Sensor ID to the TPMS control module manually.
VIN Writing	Function for inputting the VIN (Vehicle Identification Number) to the TPMS control module. (When TPMS control module is exchanged, the model should be inputted.)
Vehicle Name Writing	Function for inputting the Vehicle Name to the TPMS control module. (When TPMS control module is exchanged, the model should be inputted.)

2. Data Treatment

This is the function which can represent through GDS TPMS module.

Sensor Status	Function for checking the current status relating to the Sensor ID, Market, Tire Type, Battery Level, Pressure, Temperature, and Acceleration by wireless communicating with the sensors installed at each tire.
Register Sensor	Function for registering TPMS sensor ID to the TPMS control module by detecting through wireless communication.

1. System Identification

Using the Vehicle Name, Part No., Part Name, Manufacture Data, S/W Ver., S/W No., Sensor ID supplied by this function, the detail information relating to the TPMS system saved in the TPMS control module.

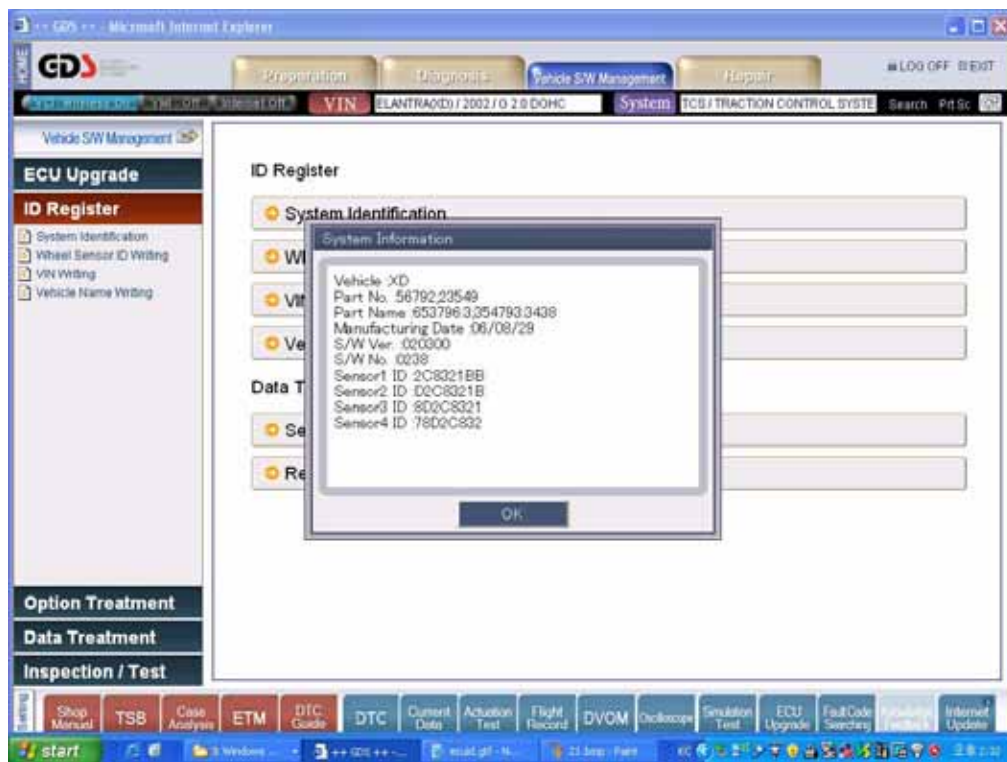

<Figure 1. System Information>

2. Wheel Sensor ID Writing

This function is to input the ID of TPMS Sensor to the TPMS control module, manually.

When the TPMS control module or the TPMS Sensor is exchanged, the TPMS Sensor ID should be registered using this function to operate the TPMS system properly.

- 1) After checking the sentence on the screen, press the “OK” button.

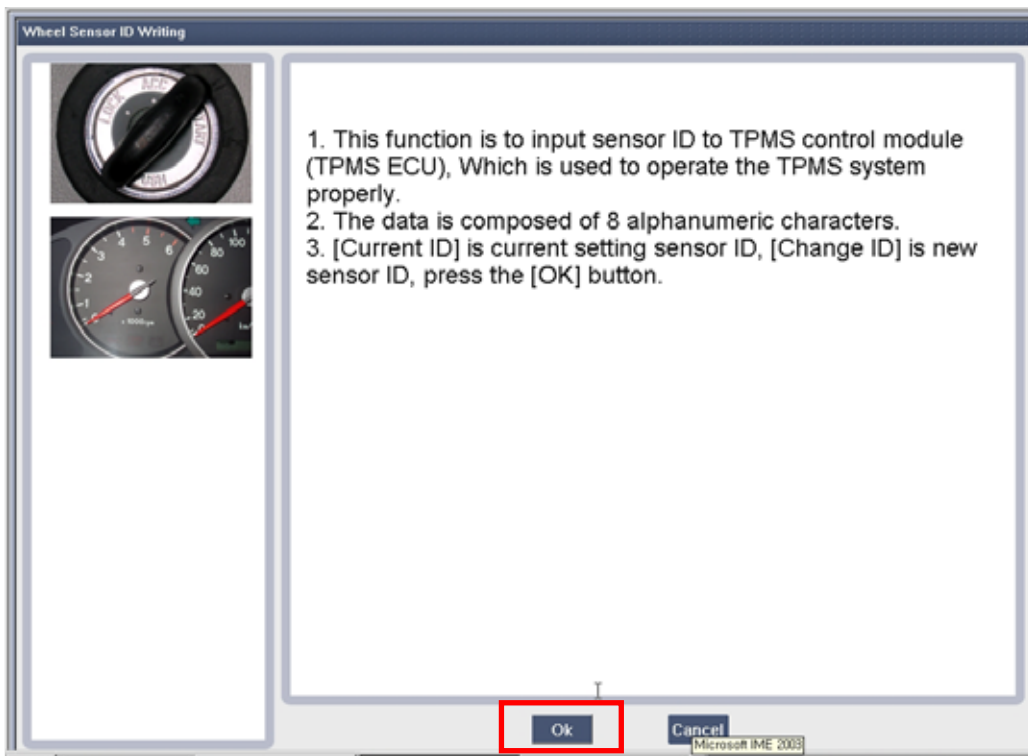

<Figure 2-1. Vehicle Condition required for registering TPMS Sensor ID >

Note:

Using GDS TPMS module at the Register Sensor function of Data Treatment, the TPMS Sensor ID can be registered automatically.

- 2) At the marked portion in the <Figure 2-2> screen, input the TPMS Sensor ID which will be registered by location correctly. The ID of TPMS sensor consists of 8 digits of Arabic numbers and alphabets.

Note:

After inputting each newly applied TPMS sensor ID, press “Save” button to save the TPMS sensor ID.

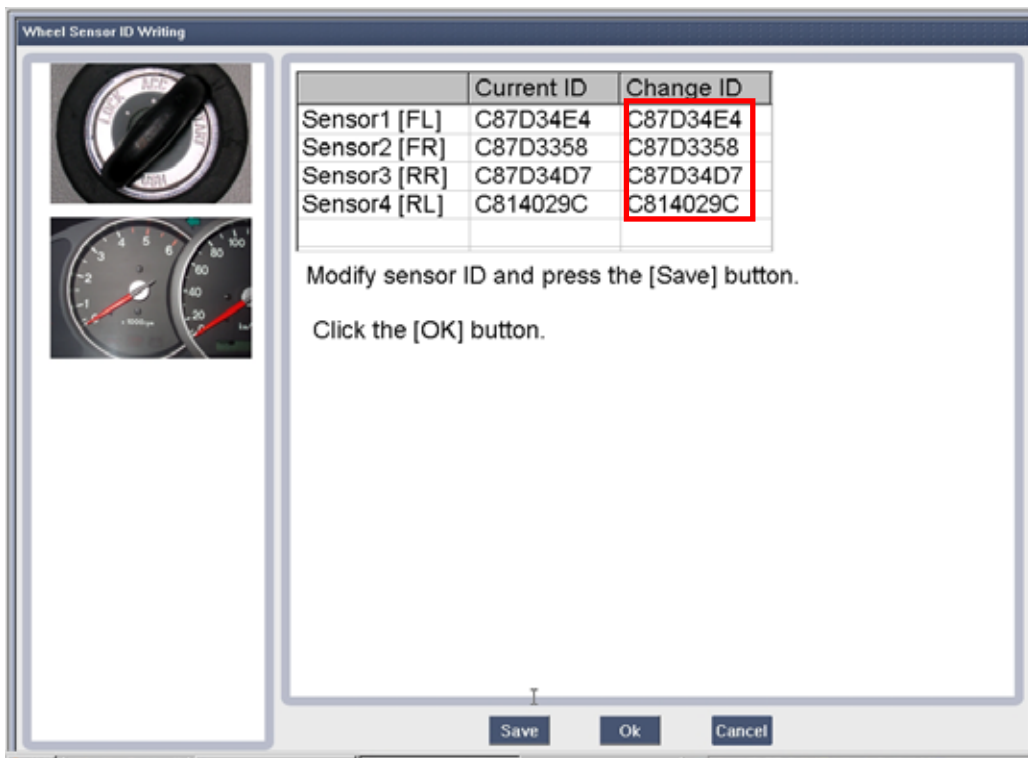

<Figure 2-2. TPMS Sensor ID Input>

- 3) After completing the new TPMS Sensor ID registration, following message box will be shown.

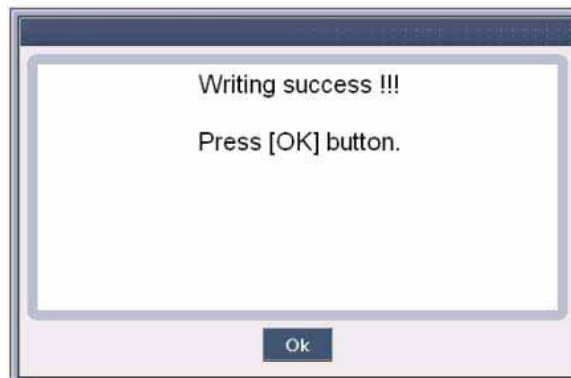

<Figure 2-3. TPMS Sensor ID Register Completion>

3. VIN Writing

This function is used to register the VIN (Vehicle Identification Number) into the TPMS control module.

When the TPMS control module is exchanged, the VIN should be registered using this function to operate the TPMS system properly.

- 1) After checking the sentence on the screen, press the “OK” button.

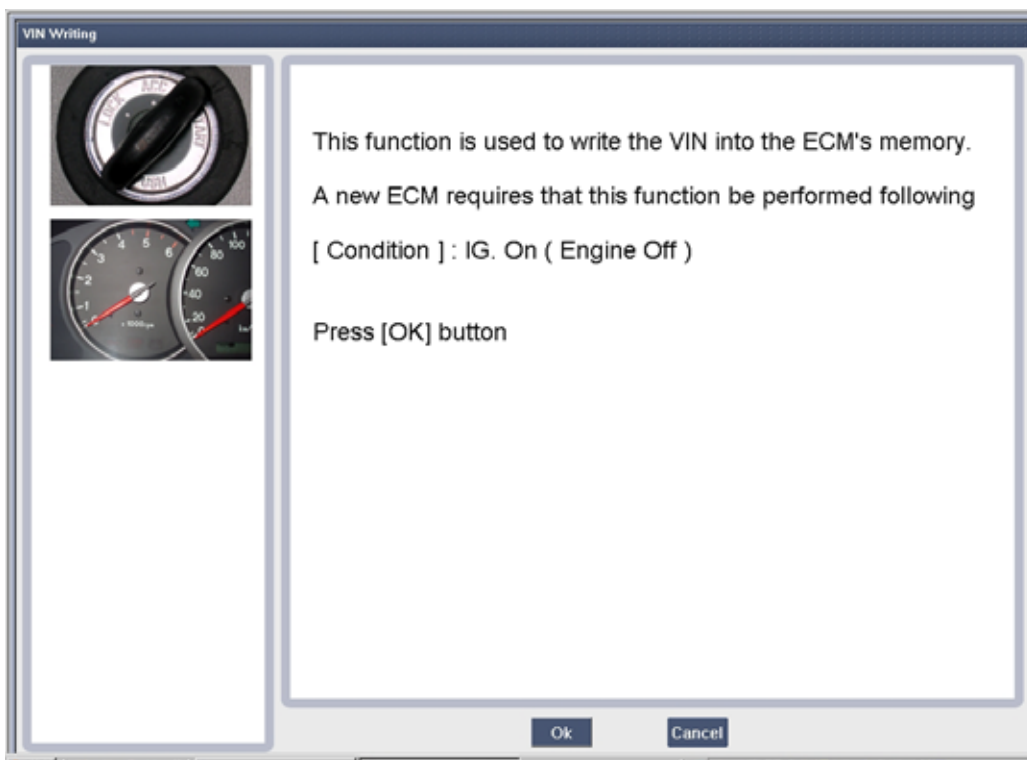

<Figure 3-1. VIN Writing Execution>

- 2) After inputting the VIN in the empty space shown in <Figure 3-2> correctly, press the “OK” button.

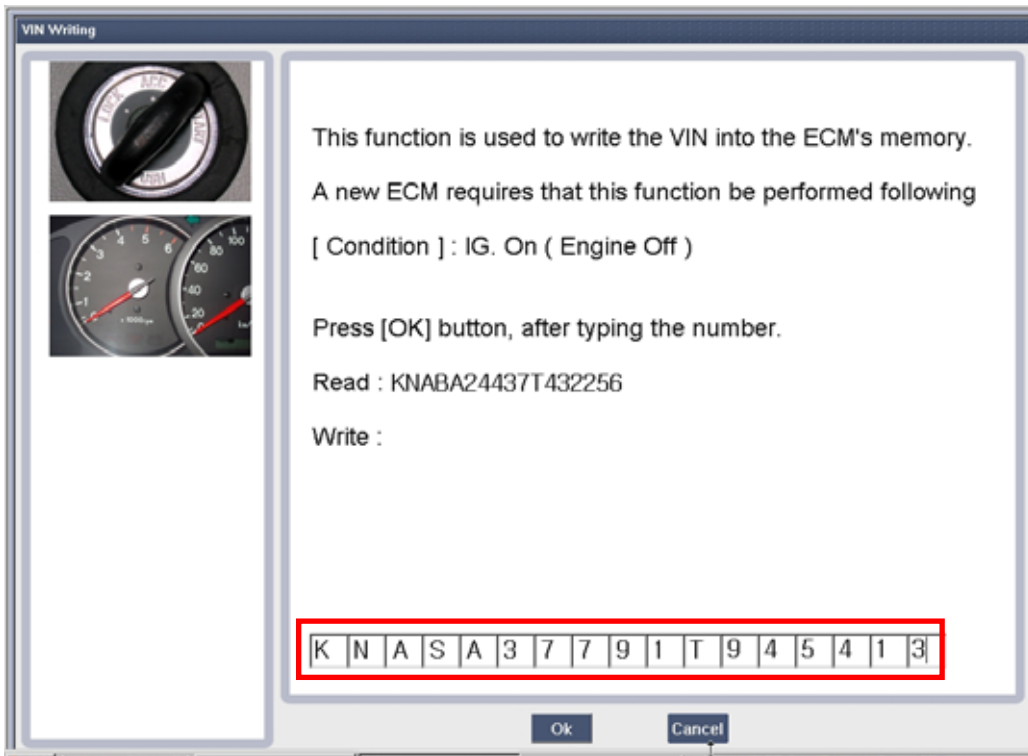

<Figure 3-2. VIN Input>

- 3) Completing VIN registration, following message will be shown.

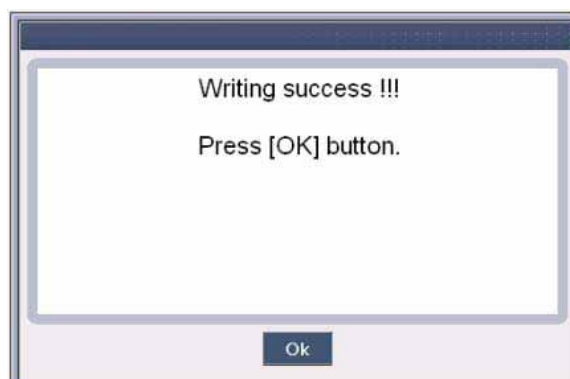

<Figure 3-3. VIN Registration Completion>

4. Vehicle Name Writing

This function is to input the Vehicle Name to the TPMS control module.

When TPMS control module is exchanged, the Vehicle Name should be registered correctly to the newly installed TPMS control module to operate the TPMS properly.

- 1) After checking the sentence on the screen, press the “OK” button.

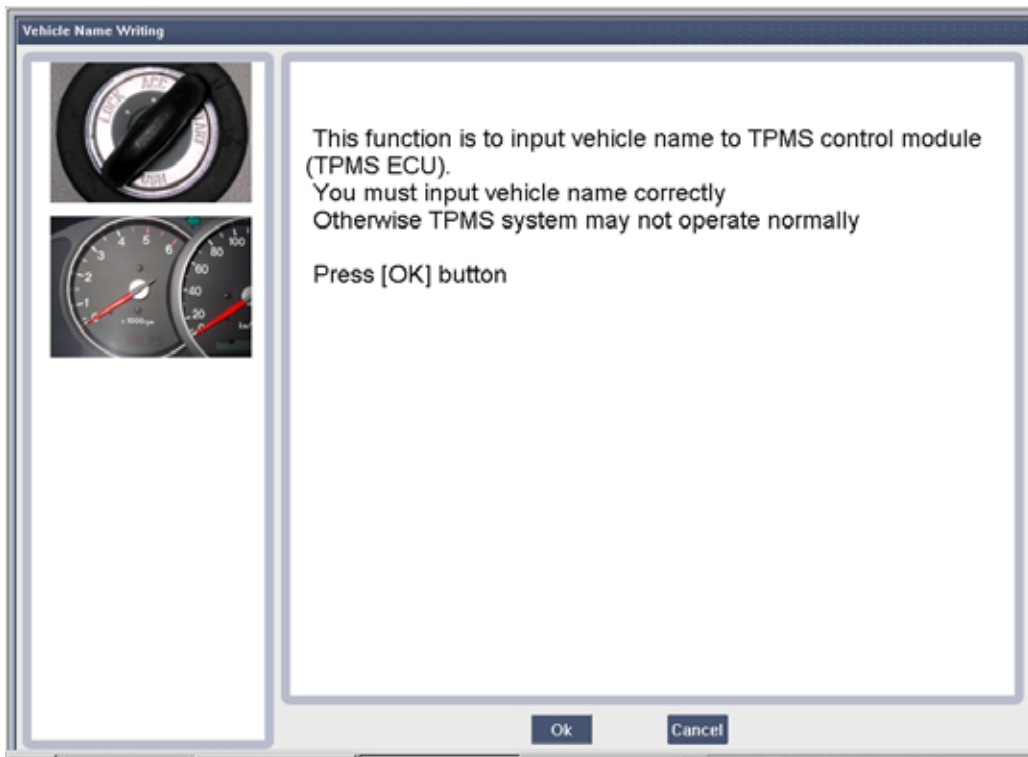

<Figure 4-1. Vehicle Name Writing Execution>

2) On the check box shown in <Figure 4-2>, the Vehicle Name can be checked.

Note:

The Vehicle Name shown through the check box shown in the <Figure 4-2> is the vehicle name selected by user when selecting the system of GDS Software automatically so that the user can not input arbitrarily.

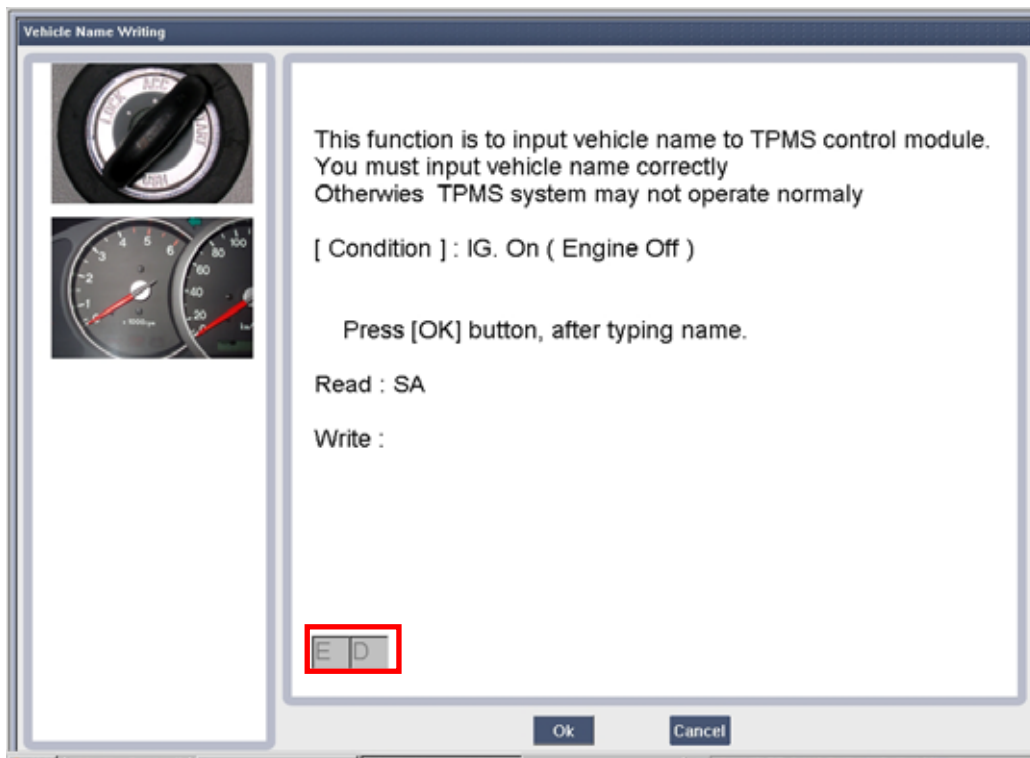

<Figure 4-2. Vehicle Name Writing >

3) Completing Vehicle Name registration, following message box will be shown.

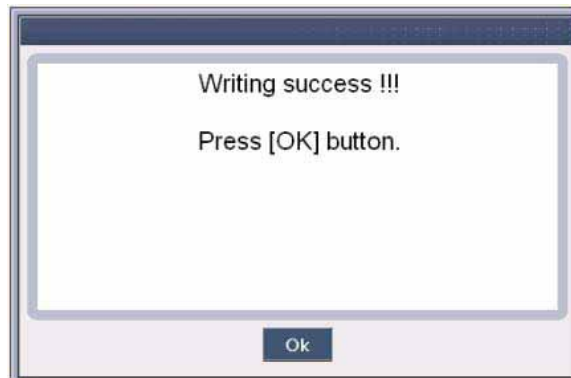

<Figure 4-3. Vehicle Name Writing Completion>

1. Sensor Status

Using GDS TPMS module, you can check the Current status of tire and TPMS sensor measured from each sensor.

- 1) After checking the sentence on the screen, press the “OK” button.

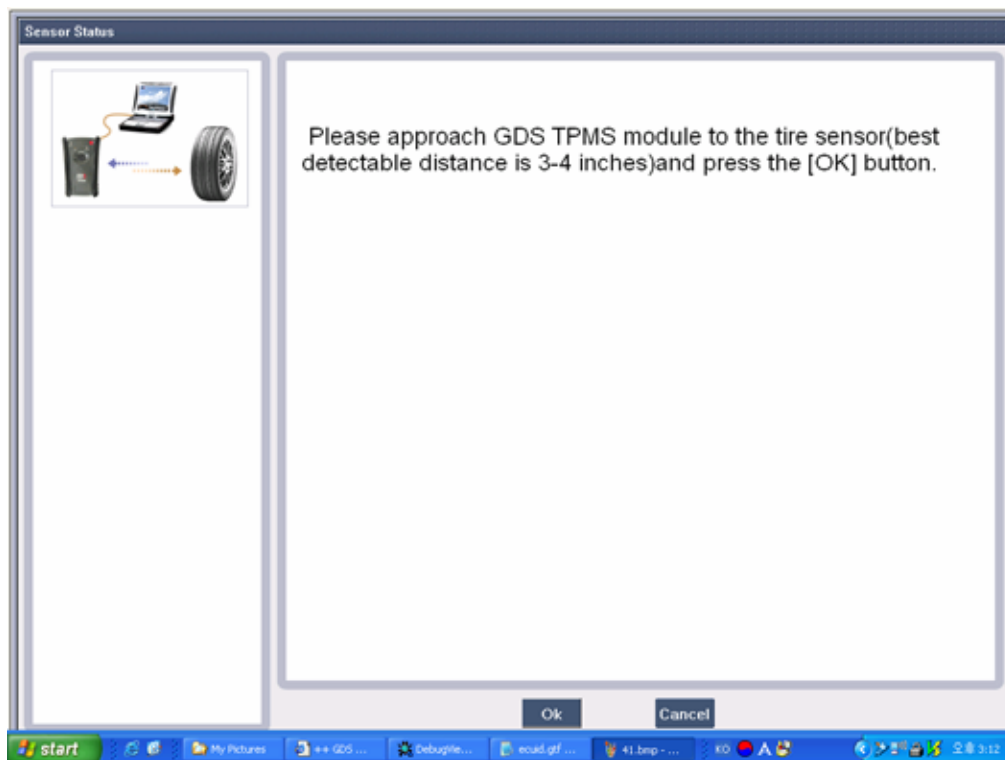

< Figure 1-1. Sensor Status Execution >

2) You can check the tire status through the wireless communication with the TPMS sensors installed each tire.

Locating the GDS TPMS module at about 3~4 inches (8~11cm) apart from the TPMS sensor, measure as following method.

 Press the “Enter” button of GDS TPMS module.

 On the PC screen, press the Retry button at the bottom in each Sensor Status Display Box.

Note:

The value shown on the Sensor Status Display box of PC screen is listed according to the measuring order by GDS TPMS module.



< Figure 1-2. Sensor Status Measuring >



< Figure 1-3. Sensor Status Checking >

2. Register Sensor

ID can be checked by wireless communication with TPMS Sensor using GDS TPMS module. The checked ID can be registered to the TPMS control module.

When the TPMS control module or the TPMS Sensor is exchanged, the TPMS Sensor should be registered using Register Sensor function to operate the TPMS system properly.

- 1) After checking the sentence on the screen, press the “OK” button.

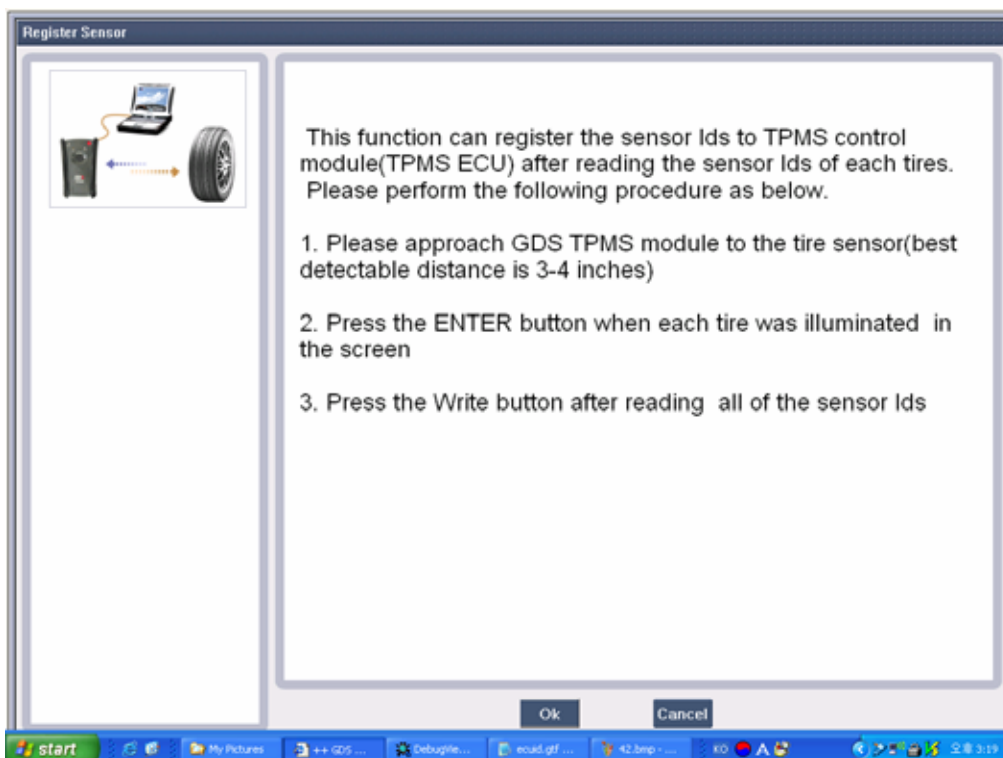

< Figure 2-1. Register Sensor Execution >

- 2) Locating the GDS TPMS module at the point 3~4 inches (8~11cm) apart from the TPMS sensor of tire indicated on the screen of PC connecting to the GDS TPMS module, press the “Enter” button.

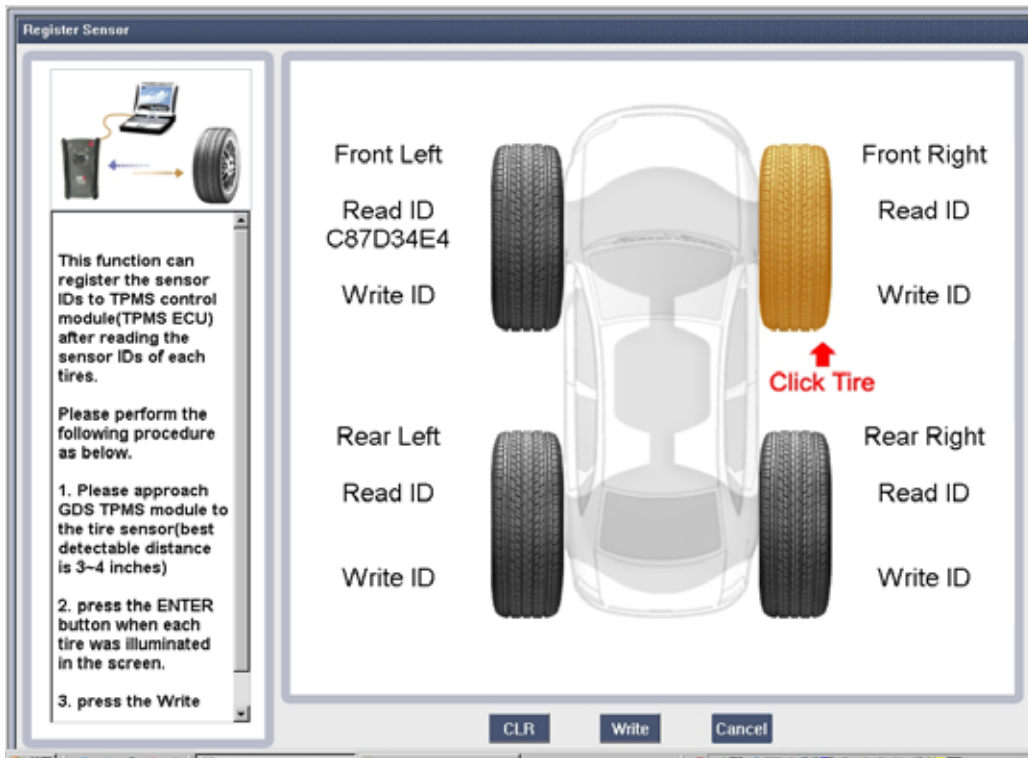

< Figure 2-2. TPMS Sensor ID reading >



< Figure 2-3. TPMS sensor ID Detecting >

- 3) After detecting ID of each TPMS sensor installed at the vehicle as shown <Figure 2-4>, press the “Write” button at the bottom of the screen then the new TPMS sensor ID will be registered to the TPMS control module.

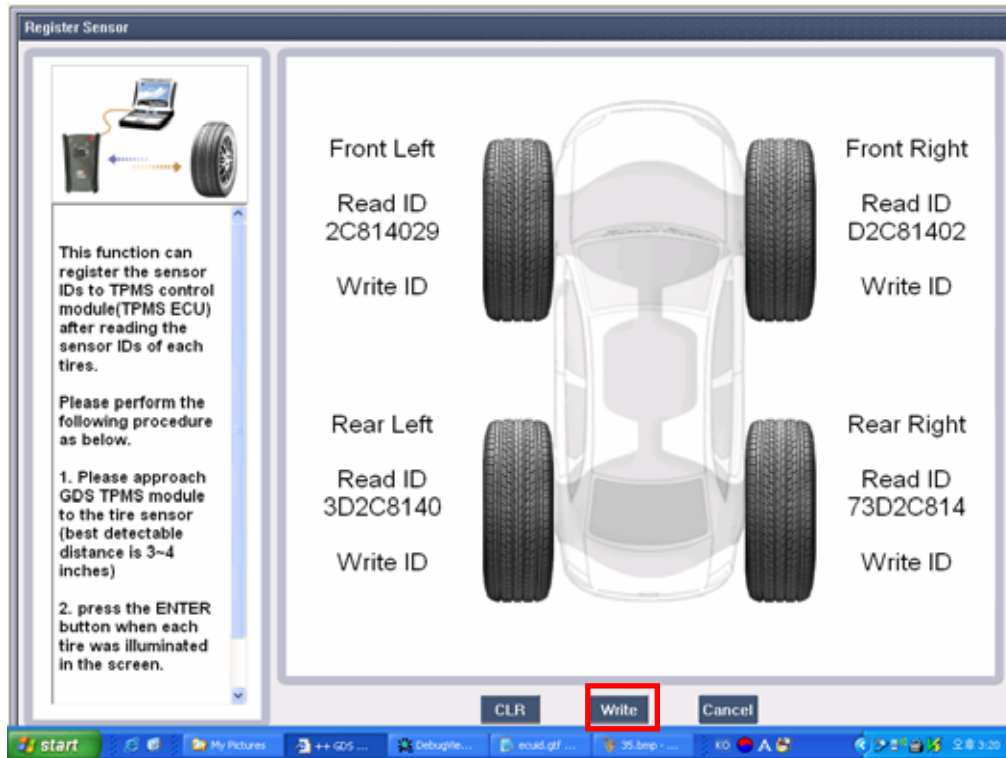

< Figure 2-4. TPMS Sensor ID Reading >

- 4) Completing TPMS Sensor ID registration, following message box will be shown.

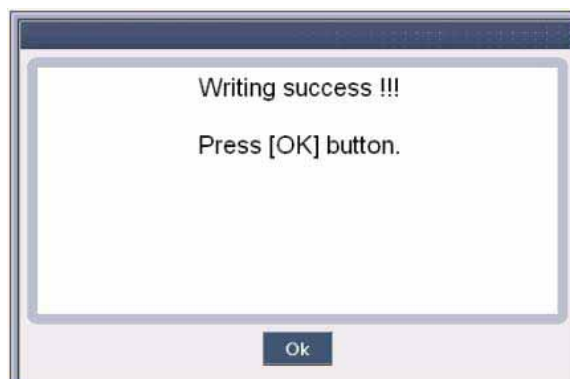

< Figure 2-5. TPMS Sensor ID registration completion >

APPENDIX

- User Maintenance A-13-001
- GDS TPMS AND PERIPHERALS LIMITED WARRANTY A-13-002
- Disposal of Old Electrical and Electronic Equipment A-13-003

When rechargeable battery of TPMS is exchanging, please comply with the following instructions.



Warning

Do not disassemble the TPMS module in any case except at exchanging the rechargeable battery.

If the product is damaged by user's carelessness, it is not responsible to the GIT.

1. Battery Removal

- 1) Remove the two coupling bolts of the rechargeable battery cover as shown in the <Figure 1>.

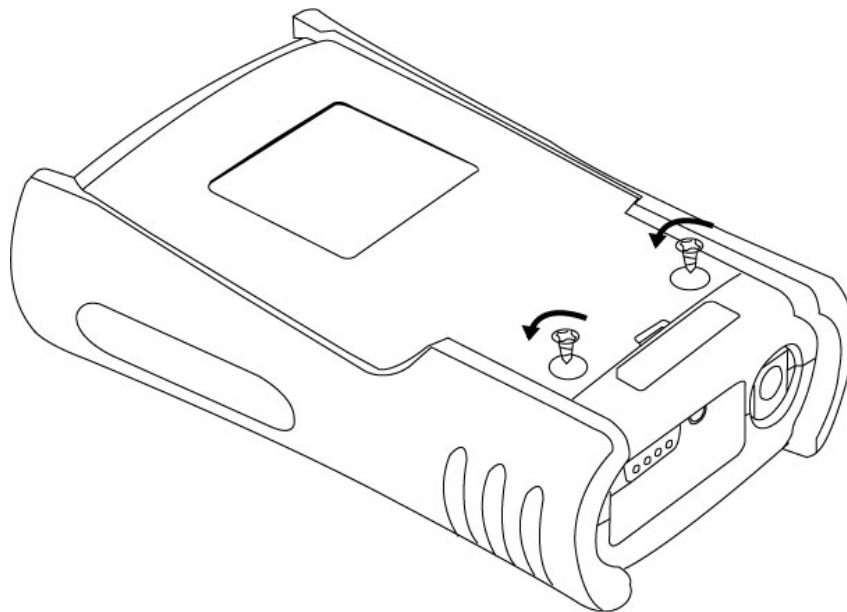

<Figure 1. Rechargeable Battery Cover Bolt Removal>

- 2) Remove the rechargeable battery cover along to the direction as shown in < Figure 2>.

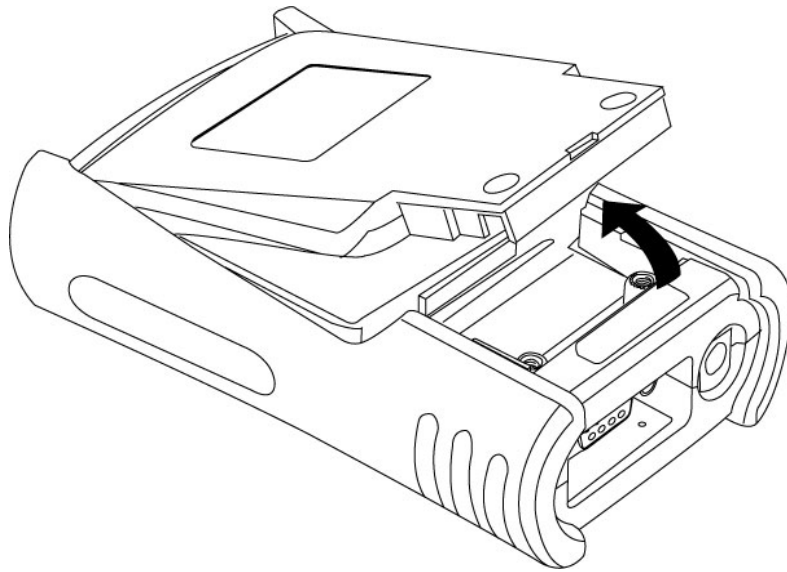

< Figure 2. Rechargeable Battery Cover Removal >

- 3) Remove the rechargeable battery as shown in < Figure 3>.

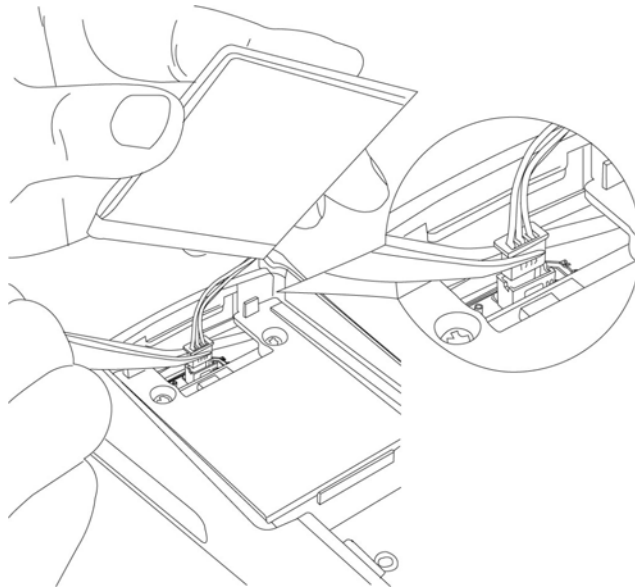

< Figure 3. Rechargeable Battery Removal >



Caution

When removing rechargeable battery connector, hold the connector body.

2. Battery Installation

- 1) Install the rechargeable battery as shown in < Figure 4 >.

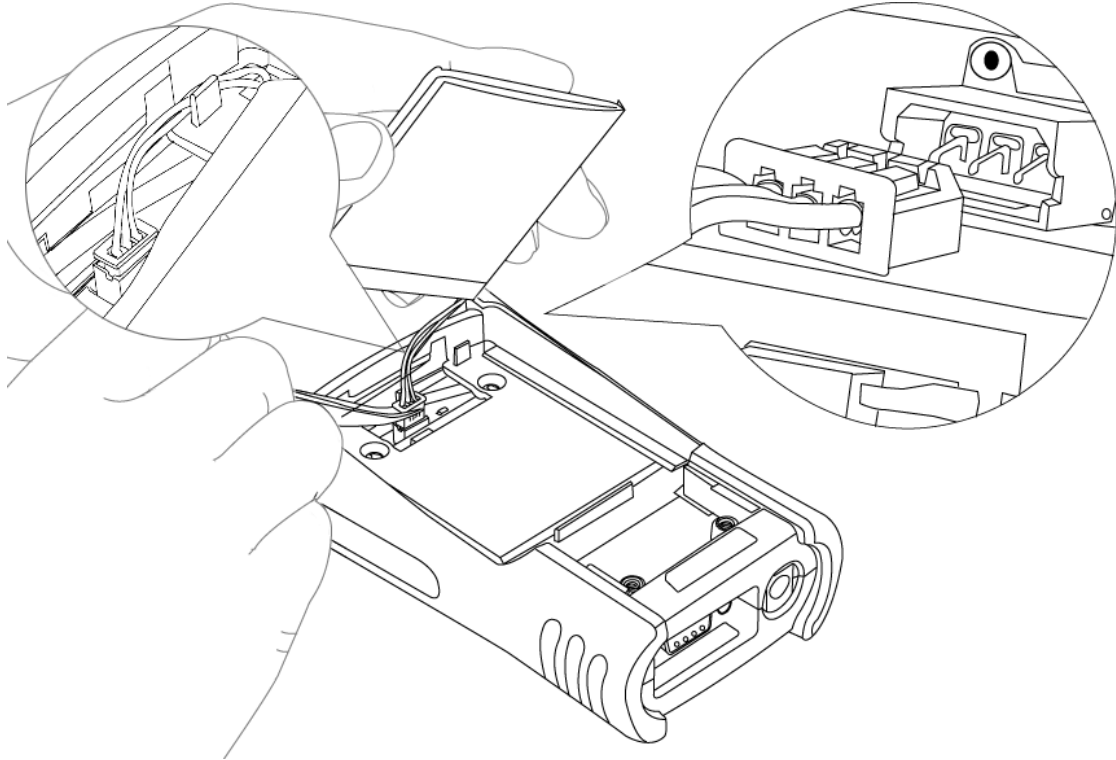

< Figure 4. Rechargeable Battery Installation >



Caution

When connecting the rechargeable battery connector to the TPMS module, please check the shape of connector.

Arrange the connector wires of rechargeable battery not to interfere with the body case or the rechargeable battery cover..

- 2) Take on the rechargeable battery cover along to the direction and according to the order as shown in < Figure 5>.

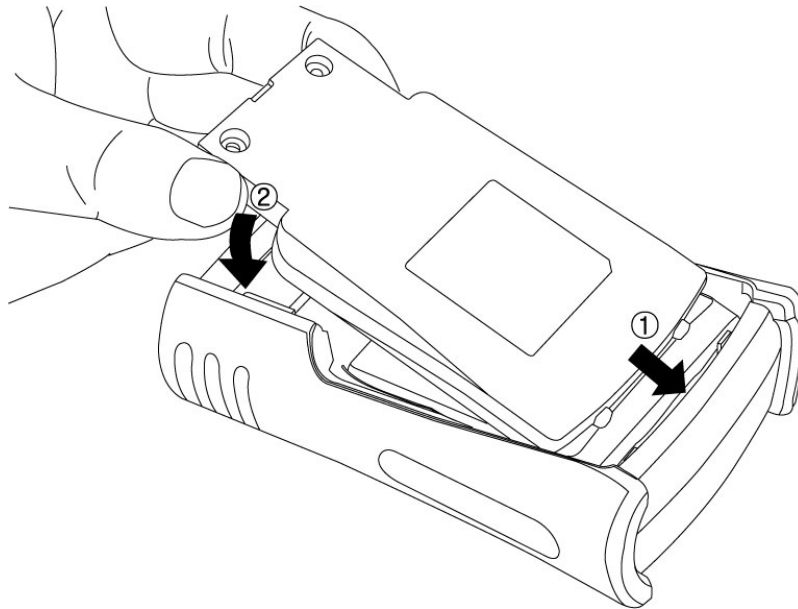

< Figure 5. Rechargeable Battery Cover Installation >

- 3) Assemble the bolts as shown in the following figure.

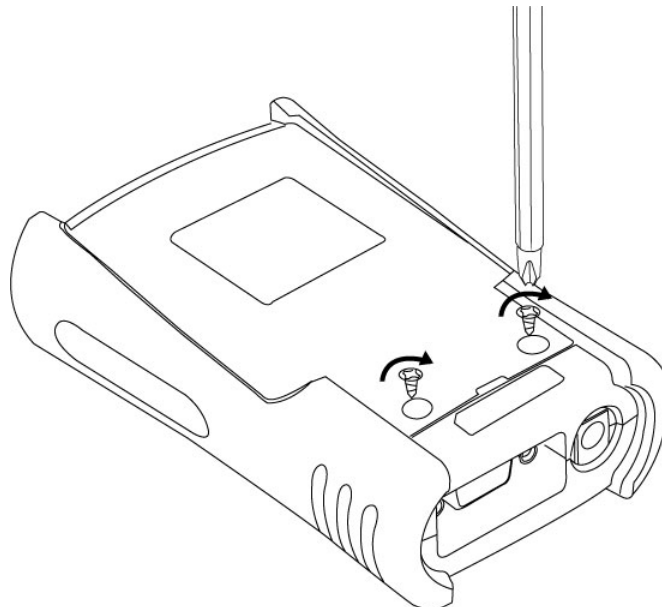

< Figure 6. Tightening Bolts >



GDS TPMS and Peripherals Limited Warranty



Providing that this product has been installed and used as instructed in the operation manual, Global Information Technology (referred to as “GIT”) will repair GDS TPMS module (main body other than software, which is covered by a separate warranty) with new or rebuilt parts, free of charge for three (3) years from the date of original purchase in the event of a defect in materials or workmanship. This warranty excludes all other options and accessories, which are covered for a period of one (1) year from the date of original purchase.

This warranty is extended solely to the original purchaser. A purchase receipt or other proof of evidencing the date of original purchase will be required before warranty service is provided.

This warranty only covers failures due to defects in materials or workmanship, which may occur during normal use. It does not cover damage which occurs in shipment or failures which may be caused by products not supplied by GIT, or failures resulting from alteration, accident, misuse, introduction of liquid material or other foreign matter into the product, abuse, neglect, installation, maladjustment of consumer controls, improper maintenance, modification or service by anyone other than GIT, or damage to be attributable to acts of God.

GIT SHALL NOT BE LIABLE FOR LOSS OF DATA OR OTHER INCIDENTAL OR CONSEQUENTIAL DAMAGES RESULTING FROM THE USE OF THIS PRODUCT, OR ARISING OUT OF ANY BREACH OF THIS WARRANTY. ALL EXPRESS AND IMPLIED WARRANTIES, INCLUDING THE WARRANTIES OF

MERCHANTABILITY AND FITNESS FOR A PARTICULAR PURPOSE ARE LIMITED TO THE APPLICABLE WARRANTY PERIOD SET FORTH ABOVE.

GIT's entire liability, and your exclusive remedy under this warranty shall be limited to the replacement, of any defective parts or functions in the product, which is returned to GIT's Service Center, together with a copy of the purchase receipt, during the aforementioned warranty period. Anything in the foregoing to the contrary notwithstanding, GIT shall have no obligation for any defects in the product resulting from your storage thereof, or for defects that have been caused by operation of the product other than on the operation manual or in environmental conditions other than those specified by GIT or by alteration, accident, misuse, abuse, neglect, mishandling, misapplication, installation, maladjustment of consumer controls, improper maintenance, modification of damage that is attributable to acts of God.

This limited warranty gives you specific legal rights, and you may also have other rights, which vary from country to country. The laws of Republic Korea, without regard to its conflict-of-laws rules, will govern this Limited Warranty.

To obtain help or technical Assistance, please contact your product supplier or distributor.



Disposal of Old Electrical and Electronic Equipment



WEEE (Waste Electrical and Electronic Equipment) symbol shown in [Figure 1] is indicated on the back of GDS TPMS main module

Please follow the regulation guide for disposal of Waste Electrical and Electronic Equipment.



<Figure 1: WEEE Symbol>

Disposal of Old Electrical & Electronic Equipment (Applicable in the European Union and other European countries with separate collection systems)

This symbol on the product or on its packaging indicates that this product shall not be treated as household waste. Instead it shall be handed over to the applicable collection point for the recycling of electrical and electronic equipment. By ensuring this product is disposed of correctly, you will help prevent potential negative consequences for the environment and human health, which could otherwise be caused by

Inappropriate waste handling of this product. The recycling of materials will help to conserve natural resources. For more detailed information about recycling of this product, please contact your local city office, your household waste disposal service or the shop where you purchased the product.

CAUTION: Changes or modifications not expressly approved by the party responsible for compliance could void the user's authority to operate the equipment.

This device complies with part 15 of the FCC Rules. Operation is subject to the following two conditions:
(1) This device may not cause harmful interference, and (2) this device must accept any interference received, including interference that may cause undesired operation.



NOTE: This equipment has been tested and found to comply with the limits for a Class B digital device, pursuant to Part 15 of the FCC Rules. These limits are designed to provide reasonable protection against harmful interference in a residential installation. This equipment generates, uses and can radiate radio frequency energy and, if not installed and used in accordance with the instructions, may cause harmful interference to radio communications. However, there is no guarantee that interference will not occur in a particular installation. If this equipment does cause harmful interference to radio or television reception, which can be determined by turning the equipment off and on, the user is encouraged to try to correct the interference by one or more of the following measures:

- Reorient or relocate the receiving antenna.
- Increase the separation between the equipment and receiver.
- Connect the equipment into an outlet on a circuit different from that to which the receiver is connected.
- Consult the dealer or an experienced radio/TV technician for help.

CE 0678