

Jabra[®]

Jabra PRO™ 920



A BRAND BY

GN Netcom

© 2011 GN Netcom A/S. All rights reserved. Jabra[®] is a registered trademark of GN Netcom A/S. All other trademarks included herein are the property of their respective owners.
(Design and specifications subject to change without notice).

MADE IN CHINA
Type: WHB003BS/HS



M105

DESIGN REGISTRATION PENDING INTERNATIONAL

REGISTER YOUR JABRA AT JABRA.COM/REGISTER - FOR NEWS, SUPPORT AND COMPETITIONS
www.jabra.com

81-03148 E

Quick Start Guide

www.jabra.com

CUSTOMER SUPPORT

EUROPE

Belgique/Belgium	+ 49 (0)8031 2651 72
Czech Republic	+ 420 800 522 722
Danmark	Kontakt venligst din nærmeste forhandler (via følgende link) www.jabra.dk/forhandler
Deutschland	+ 49 (0)8031 2651 72
España	+34 916 398 064
France	+ 33 (0) 130 589 075
Italia	+39 02 5832 8253
Luxembourg	+ 49 (0)8031 2651 72,
Nederland	+ 49 (0)8031 2651 72
Norge	+ 47 32 22 74 70
Österreich	+ 49 (0)8031 2651 72
Poland	0-801-800-550; + 48 12 254-40-15
Russia	techsupport.ru@jabra.com
Suomi	+ 358 204 85 6040
Sverige	+ 46 (0)8 693 09 00
United Kingdom	+ 44 (0)1784 220 172

ASIA

Australia	1-800-636-086 (local distributor)
China	+ 86-21-5836 5067
Hong Kong	800-968-265 (Toll free)
India	000-800-852-1185 (Toll free)
Indonesia	001-803-852-7664
Japan	+ 81-3-5297-7976
Malaysia	1800-812-160 (Toll free)
New Zealand	0800-447-982 (Toll free)
Philippines	1800-765-7022 (ETPI) 1800-1855-0144 (PLDT)
Singapore	800-8523-794 -(Toll free)
Taiwan	0080-186-3013 (Toll free)
Thailand	001-8008523-794 (Toll free)

For more languages please refer to the manuals on the CD.

MIDDLE EAST/AFRICA

E-mail Support: support.mea@gn.com

USA & CANADA

Canada	1-800-489-4199
USA	1-800-826-4656

GN Netcom A/S
Lautrupbjerg 7
DK-2750 Ballerup
Denmark

WEB

www.jabra.com (for the latest support information and online User Manuals).

LANGUAGES

ENGLISH / US	2
FRANÇAIS / FR	10
DEUTSCH / DE	18
ESPAÑOL / ES	26
繁體中文 / CHT	34

PACKAGE CONTENTS

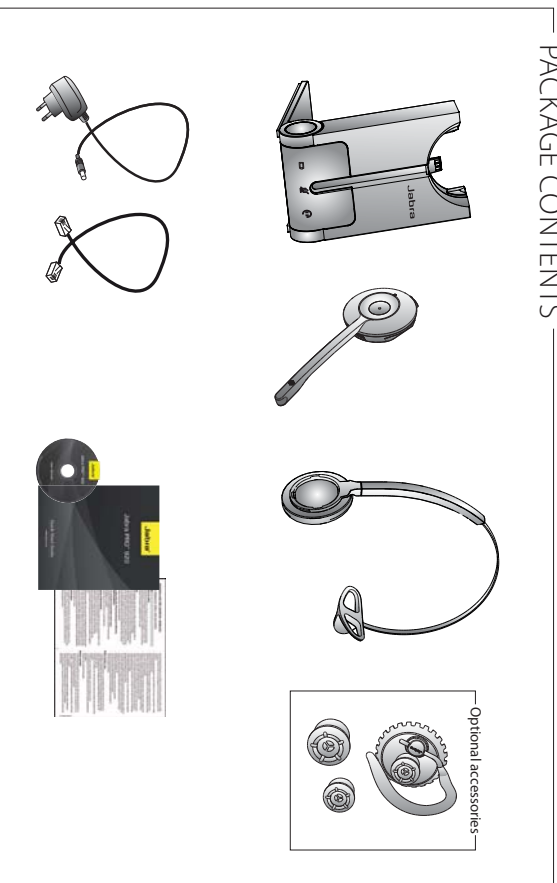

JABRA PRO 920 HEADSET

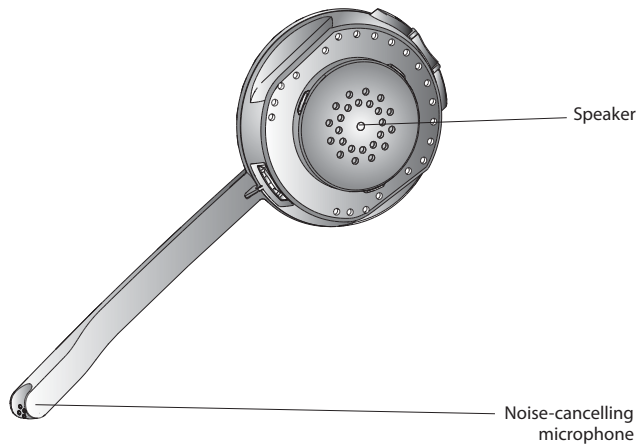
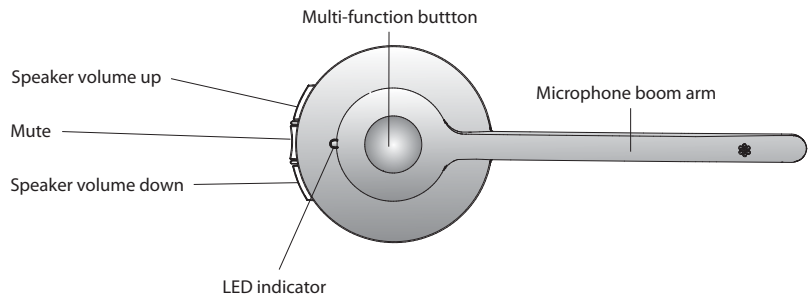

2

JABRA PRO 920 BASE

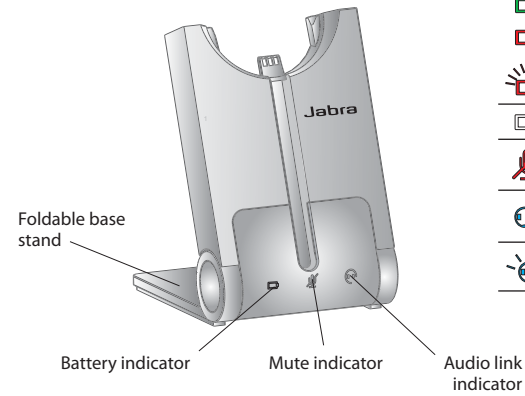

Icon	Event
	Battery charging (slow flash)
	Full battery
	Low battery
	Very low battery (fast flash)
	Unknown battery status
	Microphone muted
	Active audio link between headset and base
	Searching for headset

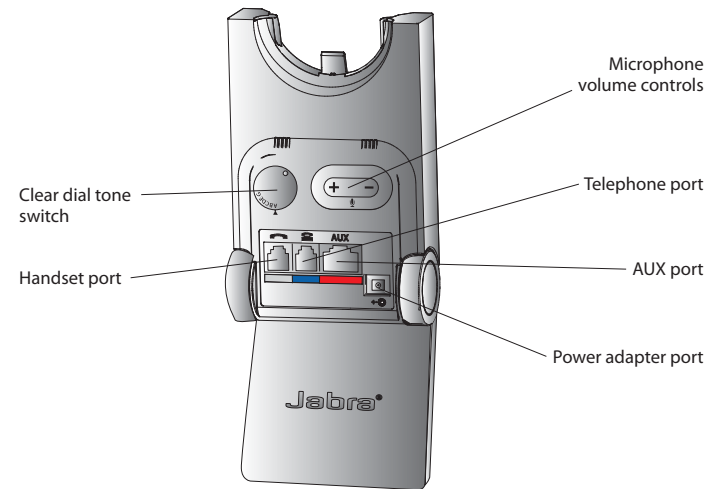

3

SETUP

STEP 1: ATTACH THE HEADBAND

1. Align the headset and the headband wearing-style attachment, as illustrated, and press firmly together until they click into place (snap-to-click).
2. Rotate the microphone boom arm for left or right ear use.
3. Adjust the length of the headband to fit snug against the head.

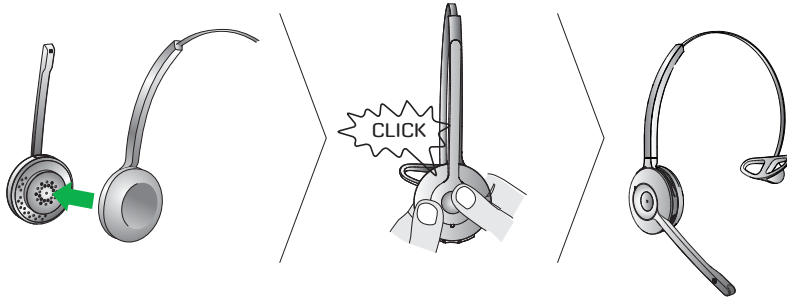

OPTIONAL ACCESSORIES

Attaching the earhook (not supplied in all regions)

1. Assemble the earhook wearing-style attachment for left or right ear use. If necessary, remove the earbud and replace with another size for best fit.
2. Align the headset and the earhook wearing-style attachment, as illustrated, and press firmly together until they click into place (snap-to-click).
3. Shape the earhook to fit snug around the ear.

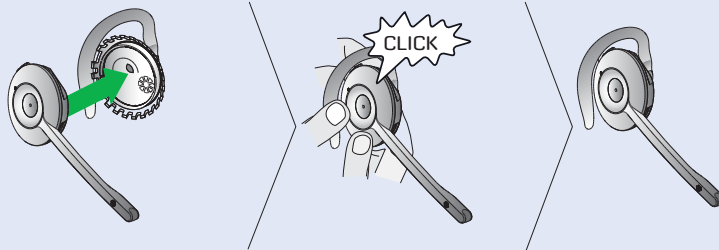

4

STEP 2: UNFOLD THE BASE

The Jabra PRO base stand can be folded into three positions: open, closed, and standing position.

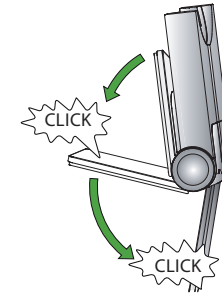

STEP 3: CONNECT TO POWER

1. Plug the supplied power adapter into the port marked  on the base.
2. Connect the power adapter to the mains power socket.

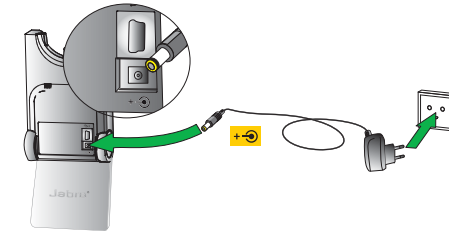

STEP 4: DOCK THE HEADSET

Dock the headset. When docked correctly the headset battery will begin charging, if needed.

Charge for 20 minutes or until the battery indicator on the base  is steady green. **Keep the headset docked during setup.**

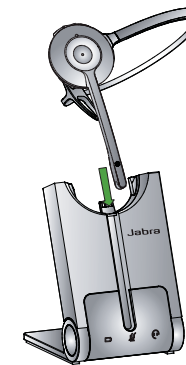



5

STEP 5: SELECT AND CONNECT TO A DESK PHONE

Select which desk phone you are connecting to from the following 4 options:

OPTION 1
Desk Phone with Headset Port

This type of desk phone has a dedicated headset port (usually at the back of the phone). These phones typically have a button on the front panel for switching between handset and headset.

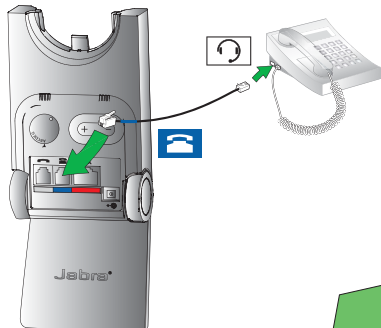

1. Plug the supplied telephone cable into the port marked  on the base.
2. Connect the telephone cable to the headset port  on the desk phone.



or

OPTION 3
Desk Phone with GN1000 remote Handset Lifter

The GN1000 remote handset lifter manually lifts the desk phone handset to make or answer a call. For mounting instructions refer to documentation supplied with the GN1000.

1. On the desk phone, unplug the handset cable from the phone body.
2. Connect the handset cable to the port marked  on the base.
3. Plug the supplied telephone cable into the port marked  on the base.
4. Connect the telephone cable into the handset port on the desk phone.
5. Connect the GN1000 cable into the port marked **AUX** on the base.

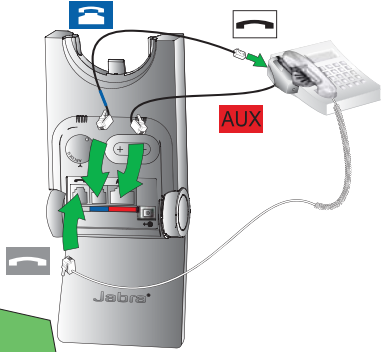

or

OPTION 2
Desk Phone with Jabra Link

A Jabra Link adapter enables an incoming call to be answered or ended by the headset multi-function button.

Contact your local Jabra dealer to purchase a Jabra Link adapter for your specific desk phone.

1. Connect the Jabra Link adapter as shown in adapter documentation supplied with the Jabra Link. On some phones the telephone cable will also need to be connected.
2. Call your connected desk phone using another phone to enable the Jabra Link adapter. Wait 10 seconds before answering the phone.

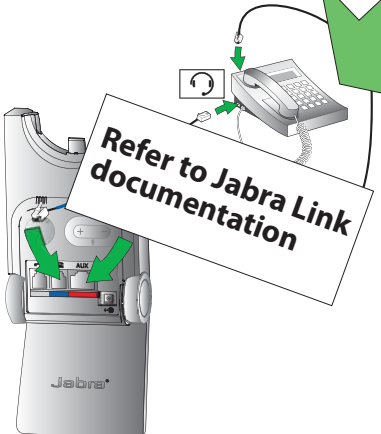



or

Refer to Jabra Link documentation

OPTION 4
Desk Phone without Headset Port

This desk phone does not have a dedicated headset port.

1. On the desk phone, unplug the handset cable from the phone body.
2. Connect the handset cable to the port marked  on the base.
3. Plug the supplied telephone cable into the port marked  on the base.
4. Connect the telephone cable into the handset port on the desk phone.

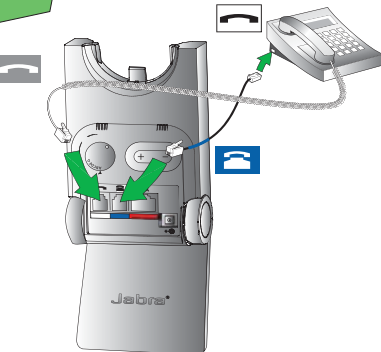

or

STEP 6: CONFIGURE THE SOUND

- 1 Put on the headset, or tap the headset multi-function button if the headset is currently undocked.
- 2 Get a dial tone by either pressing the headset button on the desk phone, or by lifting the desk phone handset. If there is no dial tone, check that all cables are connected correctly.
- 3 Dial a friend or colleagues phone number using the desk phone. If you cannot hear anything refer to 'Having sound problems?' below.
- 4 Check your speaking volume. If the listener says your speaking volume is too quiet or too loud, adjust the microphone +/- volume buttons on the back of the base. Ensure the listener does not adjust their own volume.
- 5 When finished, end the call.

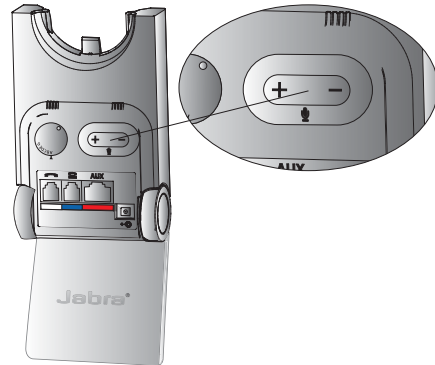

**IMPORTANT
Having sound problems?**

If you cannot hear anything during the test call, or the sound is distorted, try rotating the clear dial tone switch on the back of the base from A-G until the sound is optimal. For further details refer to section 4.1 in the user manual on the CD.

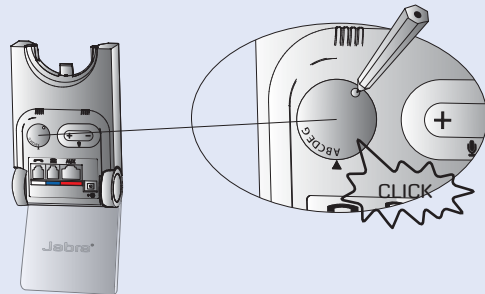

YOU HAVE NOW SUCCESSFULLY CONNECTED YOUR JABRA PRO 920

HOW TO MAKE A CALL



US

<p>OPTION A Desk phone with headset port</p>	
<p>OPTION B Desk phone without headset port</p>	
<p>OPTION C Desk phone with GN1000 or electronic hookswitch</p>	