



On-Camera Video LED Light - LED Dual Color

PT-DVL308C2

USER GUIDE

BEFORE USING YOUR NEW PRODUCT,
PLEASE READ THESE INSTRUCTIONS TO PREVENT ANY DAMAGE.



PT-DVL308C2

On-Camera Video LED Light - LED Dual Color

Contents

Welcome	3
Important safety instructions	3
Features	4
Package contents	4
Front view	5
Back view	6
Remote control	7
LCD panel (video light and remote control)	8
Setting up your flash	9
Providing power to your video light	9
Understanding the remote control	11
Using your video light	12
Mounting your video light	12
Turning your video light on and off	13
Selecting the brightness and color temperature ..	13
Setting the channel and group	14
Specifications	15
Legal statements	16
One-year limited warranty - Platinum	17

PT-DVL308C2 On-Camera Video LED Light - LED Dual Color

Welcome

Congratulations on your purchase of a high-quality Platinum product. Your PT-DVL308C2 on-camera video light represents the state-of-the-art in video light design and is designed for reliable and trouble-free performance.

Important safety instructions

- 1 Read these instructions.
- 2 Keep these instructions.
- 3 Heed all warnings.
- 4 Follow all instructions.
- 5 Do not use this apparatus in the water.
- 6 Clean only with a dry cloth.
- 7 Install in accordance with the manufacturer's instructions.
- 8 Do not store near any heat sources such as radiators, heat registers, stoves, or other apparatus (including amplifiers) that produce heat.
- 9 Only use attachments/accessories specified by the manufacturer.
- 10 Refer all servicing to qualified service personnel. Servicing is required when the apparatus has been damaged in any way, liquid has been spilled or objects have fallen into the apparatus, the apparatus has been exposed to rain or moisture, does not operate normally, or has been dropped.
- 11 To reduce the risk of fire or electric shock, do not expose this device to rain, moisture, dripping, or splashing, and no objects filled with liquids, such as vases, shall be placed on it.

3



 PLATINUM™



Features

Package contents

- LED video light
- Remote control
- Diffusion filter
- Rechargeable Lithium Ion battery
- Battery charger
- AC adapter
- Mini stand
- Handle
- *User Guide*
- *Quick Start Guide*

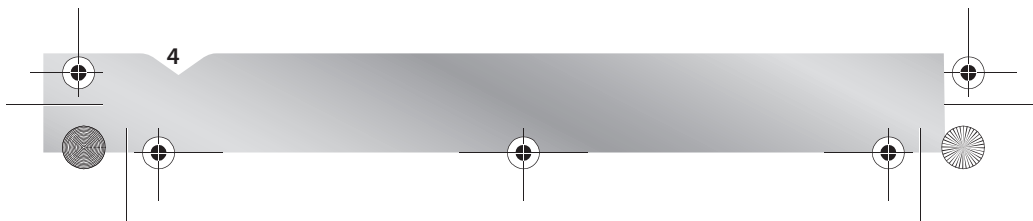
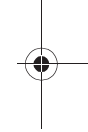
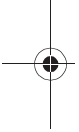

PT-DVL308C2 On-Camera Video LED Light - LED Dual Color

Front view

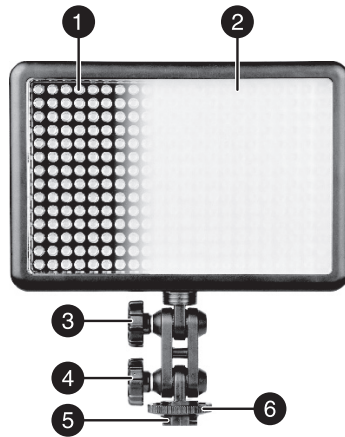

#	Item	Description
1	LEDs (308)	Provide the light.
2	Diffusion filter	Helps to diffuse the light to provide a more uniform and softer illumination.
3	Upper angle adjusting knob	Sets the vertical angle of the video light. Use in conjunction with the lower angle adjusting knob to obtain the desired light angle.
4	Lower angle adjusting knob	Sets the vertical angle of the video light. Use in conjunction with the upper angle adjusting knob to obtain the desired light angle.
5	Camera hot shoe connector	Slides into your camera's hot shoe to mount the video light to your camera.
6	Locking ring	Secures the video light to your camera's hot shoe.



PLATINUM

Back view

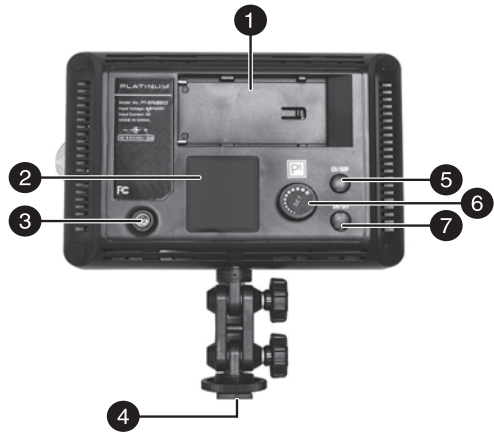

#	Item	Description
1	Battery compartment	Install the included NP-550/570 rechargeable battery into this compartment to power the video light.
2	LCD panel	Displays setting and status information.
3	DC IN power jack	Connect an AC adapter (6.5~12VDC - provided) to this jack to power your video light using external power.
4	Mounting hole	1/4-in mounting hole to mount your video light on the handle or a tripod.
5	CH/GRP button	Enables the Select dial to set the channel and group. Press once for group and twice for channel.

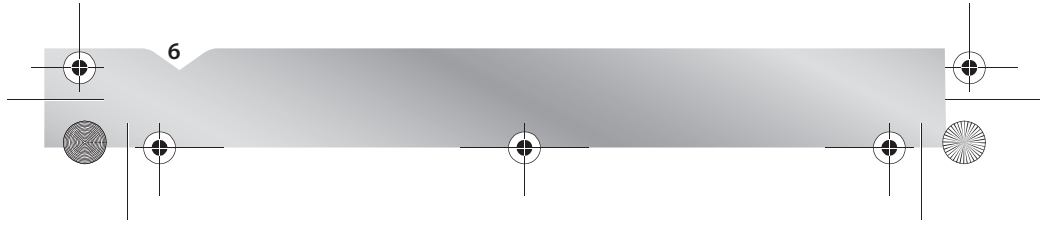

PT-DVL308C2 On-Camera Video LED Light - LED Dual Color

#	Item	Description
6	Select dial/ SET button	Turn the Select dial to set the brightness of your video light. Press the SET button, then turn the Select dial to adjust the color temperature of your video light. Turn to select the channel or group when enabled by pressing the CH/GRP button.
7	Power button	Press to turn your video light on or off.

Remote control

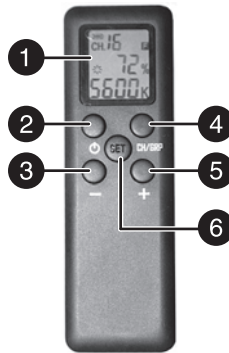

#	Item	Description
1	LCD panel	Displays information and video light settings.
2	⏻ (power) button	Press to activate or deactivate the LED groups.
3	- button	Press to adjust the light brightness and color temperature.
4	CH/GRP button	Enables the + button to select the channel and group.

PLATINUM

#	Item	Description
5	+ button	Press to adjust the light brightness and color temperature. Press to select the channel or group when enabled by pressing the CH/GRP button.
6	SET button	Press to enable the + button to set the color temperature (changeable version only).

LCD panel (video light and remote control)

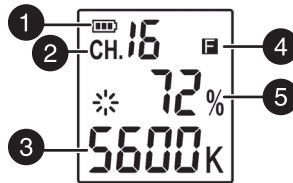

#	Item	Description
1	Battery charge indicator	Shows the current level of battery charge when using battery power.
2	Channel number	Shows the currently selected channel number. This should be the same on both the video light and the remote control. If you are using several video lights with a single remote control, select the channel of the video light you want to control on the remote control.
3	Color temperature	Shows the currently selected color temperature.
4	Controllable group	Shows the currently selected LED group.
5	Brightness	Shows the currently selected brightness level.

Setting up your flash

Providing power to your video light



Battery installed



AC adapter connected

Caution

- Use only the NP-550 or NP-570 Lithium Ion battery (provided) with your video light. Use of any other type of battery may damage your video light and void your warranty.

Notes

- When you use the Lithium Ion battery to power your video light, the battery charge level is shown on the LCD panel. When the indicator blinks, the battery charge level is low and it should be recharged.
- When you use the AC adapter (provided) to power your video light, no indicator is displayed when the voltage is above 10V.
- The AC adapter does not charge the battery when installed on the video light. To charge the battery, use the battery charger provided.

PLATINUM

Installing the Lithium Ion battery

- 1** Insert the NP-550 or NP-570 Lithium Ion battery into the battery compartment and slide it in until it locks. Make sure that the + and – match what is indicated in the compartment.



- 2** Turn on your video light using the button on the back of the light or the remote control.

Connecting the optional AC adapter

- 1** Turn off the power using the button on the back of the video light.
- 2** Remove the battery.
- 3** Plug the DC output connector of the AC adapter into the DC IN jack on the back of your video light.



- 4** Plug the AC adapter into a standard wall outlet.
- 5** Turn on your video light using the button on the back of the light or the remote control.

PT-DVL308C2 On-Camera Video LED Light - LED Dual Color

Understanding the remote control

Note the following when using the remote control:

- Pressing the  (power) button on the remote control only activates or deactivates the LED groups. It does not turn off the video light. You cannot turn on the video light with the remote control.
- You can control six LED groups (A through F) and select one of 16 channels. Set the group and channel on the remote control the same as the video light.
- Press the + and - buttons to adjust the color temperature.

Installing batteries in the remote control

- 1 Turn your remote control over, then open and remove the door to the battery compartment.
- 2 Insert two (2) "AAA" size batteries into the battery compartment. Make sure that you match the + and - symbols on the batteries with the + and - symbols in the battery compartment.
- 3 Reinstall and close the battery compartment door.

Caution

Follow these precautions when using batteries in this device:

- Use only the size and type of batteries specified.
- Make sure that you follow the correct polarity as indicated in the battery compartment when installing batteries. Reversed batteries may cause damage to your remote control
- Do not mix different types of batteries together (for example, alkaline, rechargeable, and carbon zinc), or semi-used batteries with fresh ones.
- If your remote control is not to be used for a long period of time, remove the batteries to prevent damage or injury from possible battery leakage.
- Do not throw batteries into a fire. Dispose of used batteries as hazardous waste.



PLATINUM™



Using your video light

Mounting your video light

For your convenience, you have several mounting options available. You can mount your video light on any of the following:

- Directly on your camera or camcorder.



- On the handle (provided).



- On the mini-stand (provided).

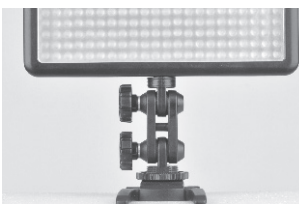

PT-DVL308C2 On-Camera Video LED Light - LED Dual Color

- On a light stand or tripod (not provided).

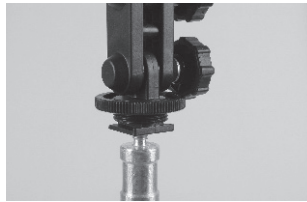

The mounting instructions are similar for all of the options. The camera or stand selected should have either a hot shoe connector or a 1/4-in screw available on which to mount your video light.

- If a hot shoe connector is available, slide the mounting foot into the hot shoe and tighten the locking ring to secure your video light.
- If a 1/4-in screw is available, screw it into the 1/4-in mounting hole on the bottom of your video light and tighten the locking ring to secure your video light.
- If neither a hot shoe connector or 1/4-in mount screw is available, you may be able to purchase a connecting bracket to facilitate mounting.

Turning your video light on and off

- 1 Press the power button on the back of your video light to turn your video light on.
The video light turns on and the LCD panel shows the current status of the light.
- 2 Press the button again to turn it off.

Selecting the brightness and color temperature

You can set the brightness level and the color temperature by using the Select dial/SET button on the back of your video light, or by using the buttons on the remote control.

PLATINUM

- 1** Adjust the brightness level (10%-100%) by turning the Set dial on the back of the video light or pressing the + button on the remote control.
The brightness level is shown on the LCD panel (on the back of the video light and on the remote control).
- 2** Adjust the color temperature by pressing the SET button (the color temperature icon blinks), then turning the Set dial on the back of the video light or pressing the + button on the remote control.
The color temperature is shown on the LCD panel (on the back of the video light and on the remote control).

Setting the channel and group

- 1** Set the group (A to F) by pressing the CH/GRP button (the group icon blinks), then turning the Set dial on the back of the video light pressing the + or – button on the remote control.
The selected group is shown on the LCD panel (on the back of the video light and on the remote control).
- 2** Set the channel (1 to 16) by pressing the CH/GRP button twice (the channel icon blinks), then turning the Set dial on the back of the video light or pressing the + or – button on the remote control.
The selected channel is shown on the LCD panel (on the back of the video light and on the remote control).

PT-DVL308C2 On-Camera Video LED Light - LED Dual Color

Specifications

Specifications are subject to change without notice.

Parameter	Rating
Battery	7.4V Lithium Ion battery (Type NP-550 or NP-570 provided)
AC adapter	9 V DC at 2.5A
Channels	16
Groups	Six (A to F)
Power	21 Watts (Max)
Color temperature	3300~5600K±300K
Brightness (LUX)	860 (3 ft/1 m) at 4100K
	430 (3 ft/1 m) at 3300K
	430 (3 ft/1 m) at 5600K
Brightness range	3300K/5600K - 10%-100%
	3400K~5500K - 25%-100%
LED quantity	5600K - 154
	3300K - 154
Operating temperature	14~122°F (-10~50°C)
Dimensions (w/o handle)	7.6 x 7.1 x 1.7 in (193.4 x 179.72 x 42.36 mm)
Weight	15.3 oz. (433.3 g)

Remote control	
Power	3.0 V (two AAA batteries - not provided)
Wireless frequency	433 MHz
Effective distance	66 ft (20 m)



Remote control	
Channels	16
Groups	Six (A to F)
Operating temperature	14~122°F (-10~50°C)
Dimensions	4.7 x 1.5 x 0.6 in (120 x 38 x 15 mm)
Weight	1.25 oz. (35.5 g)

Legal statements

FCC Caution - §15.21:

Changes or modifications not expressly approved by the party responsible for compliance could void the user's authority to operate the equipment.

FCC Statement - §15.105(b):

This equipment has been tested and found to comply with the limits for a Class B digital device, pursuant to part 15 of the FCC Rules. These limits are designed to provide reasonable protection against harmful interference in a residential installation. This equipment generates, uses and can radiate radio frequency energy and, if not installed and used in accordance with the instructions, may cause harmful interference to radio communications. However, there is no guarantee that interference will not occur in a particular installation. If this equipment does cause harmful interference to radio or television reception, which can be determined by turning the equipment off and on, the user is encouraged to try to correct the interference by one or more of the following measures:

- Reorient or relocate the receiving antenna.
- Increase the separation between the equipment and receiver.
- Connect the equipment into an outlet on a circuit different from that to which the receiver is connected.
- Consult the dealer or an experienced radio/TV technician for help.

RSS-Gen & RSS-210 statement:

This device complies with Industry Canada licence-exempt RSS standard(s). Operation is subject to the following two conditions: (1) this device may not cause interference, and (2) this device must accept any interference, including interference that may cause undesired operation of the device.

PT-DVL308C2 On-Camera Video LED Light - LED Dual Color

Le présent appareil est conforme aux CNR d'Industrie Canada applicables aux appareils radio exempts de licence. L'exploitation est autorisée aux deux conditions suivantes : (1) l'appareil ne doit pas produire de brouillage, et (2) l'utilisateur de l'appareil doit accepter tout brouillage radioélectrique subi, même si le brouillage est susceptible d'en compromettre le fonctionnement.

RSS-102 Statement:

This equipment complies with Industry Canada radiation exposure limits set forth for an uncontrolled environment.
Cet équipement est conforme à l'exposition aux rayonnements Industry Canada limites établies pour un environnement non contrôlé

One-year limited warranty - Platinum

Definitions:

The Distributor* of Platinum branded products warrants to you, the original purchaser of this new Platinum-branded product ("Product"), that the Product shall be free of defects in the original manufacturer of the material or workmanship for a period of one (1) year from the date of your purchase of the Product ("Warranty Period").

For this warranty to apply, your Product must be purchased in the United States or Canada from a Best Buy brand retail store location or www.bestbuy.com or www.bestbuy.ca that are packaged with this warranty statement.

How long does the coverage last?

The Warranty Period lasts for 1 year (365 days) from the date you purchased the Product. Your purchase date is printed on the receipt you received with the Product.

What does this warranty cover?

During the Warranty Period, if the original manufacture of the material or workmanship of the Product is determined to be defective by an authorized



Platinum repair center or store personnel, Platinum will (at its sole option): (1) repair the Product with new or rebuilt parts; or (2) replace the Product at no charge with new or rebuilt comparable products or parts. Products and parts replaced under this warranty become the property of Platinum and are not returned to you. If service of Products or parts are required after the Warranty Period expires, you must pay all labor and parts charges. This warranty lasts as long as you own your Platinum Product during the Warranty Period. Warranty coverage terminates if you sell or otherwise transfer the Product.

How to obtain warranty service?

If you purchased the Product at a Best Buy retail store location, please take your original receipt and the Product to any Best Buy store. Make sure that you place the Product in its original packaging or packaging that provides the same amount of protection as the original packaging. If you purchased the Product from a Best Buy online web site (www.bestbuy.com or www.bestbuy.ca), mail your original receipt and the Product to the address listed on the web site. Make sure that you put the Product in its original packaging or packaging that provides the same amount of protection as the original packaging.

To obtain warranty service, in the United States call 1-888-BESTBUY, Canada call 1-866-BESTBUY. Call agents may diagnose and correct the issue over the phone.

Where is the warranty valid?

This warranty is valid only in the United States and Canada at Best Buy branded retail stores or websites to the original purchaser of the product in the county where the original purchase was made.

What does the warranty not cover?

This warranty does not cover:

- Customer instruction/education
- Installation
- Set up adjustments
- Cosmetic damage
- Damage due to acts of God, such as power surges
- Accident(s)
- Misuse
- Abuse
- Negligence
- Commercial purposes/use, including but not limited to use in a place of business or in communal areas of a multiple dwelling condominium or apartment complex, or otherwise used in a place of other than a private home.

PT-DVL308C2 On-Camera Video LED Light - LED Dual Color

- Modification of any part of the Product, including the antenna
- Display panel damaged by static (non-moving) images applied for lengthy periods (burn-in).
- Damage due to incorrect operation or maintenance
- Connection to an incorrect voltage or power supply
- Attempted repair by any person not authorized by Platinum to service the Product
- Products sold "as is" or "with all faults"
- Consumables, including but not limited to batteries (i.e. AA, AAA, C, etc.)
- Products where the factory applied serial number has been altered or removed
- Loss or Theft of this product or any part of the product
- Display panels containing up to three (3) pixel failures (dots that are dark or incorrectly illuminated) grouped in an area smaller than one tenth (1/10) of the display size or up to five (5) pixel failures throughout the display. (Pixel based displays may contain a limited number of pixels that may not function normally.)
- Failures or Damage caused by any contact including but not limited to liquids, gels or pastes.

REPAIR REPLACEMENT AS PROVIDED UNDER THIS WARRANTY IS YOUR EXCLUSIVE REMEDY FOR BREACH OF WARRANTY. PLATINUM SHALL NOT BE LIABLE FOR ANY INCIDENTAL OR CONSEQUENTIAL DAMAGES FOR THE BREACH OF ANY EXPRESS OR IMPLIED WARRANTY ON THIS PRODUCT, INCLUDING, BUT NOT LIMITED TO, LOST DATA, LOSS OF USE OF YOUR PRODUCT, LOST BUSINESS OR LOST PROFITS. PLATINUM PRODUCTS MAKES NO OTHER EXPRESS WARRANTIES WITH RESPECT TO THE PRODUCT, ALL EXPRESS AND IMPLIED WARRANTIES FOR THE PRODUCT, INCLUDING, BUT NOT LIMITED TO, ANY IMPLIED WARRANTIES OF AND CONDITIONS OF MERCHANTABILITY AND FITNESS FOR A PARTICULAR PURPOSE, ARE LIMITED IN DURATION TO THE WARRANTY PERIOD SET FORTH ABOVE AND NO WARRANTIES, WHETHER EXPRESS OR IMPLIED, WILL APPLY AFTER THE WARRANTY PERIOD. SOME STATES, PROVINCES AND JURISDICTIONS DO NOT ALLOW LIMITATIONS ON HOW LONG AN IMPLIED WARRANTY LASTS, SO THE ABOVE LIMITATION MAY NOT APPLY TO YOU. THIS WARRANTY GIVES YOU SPECIFIC LEGAL RIGHTS, AND YOU MAY ALSO HAVE OTHER RIGHTS, WHICH VARY FROM STATE TO STATE OR PROVINCE TO PROVINCE.

Contact Platinum:

For customer service please call 800-499-3964

*Distributed by Best Buy Purchasing, LLC

7601 Penn Avenue South, Richfield, Minnesota, U.S.A. 55423-3645

© 2015 BBY Solutions, Inc.

All rights reserved. PLATINUM is a trademark of BBY Solutions, Inc. Registered in some countries. All other products and brand names are trademarks of their respective owners.

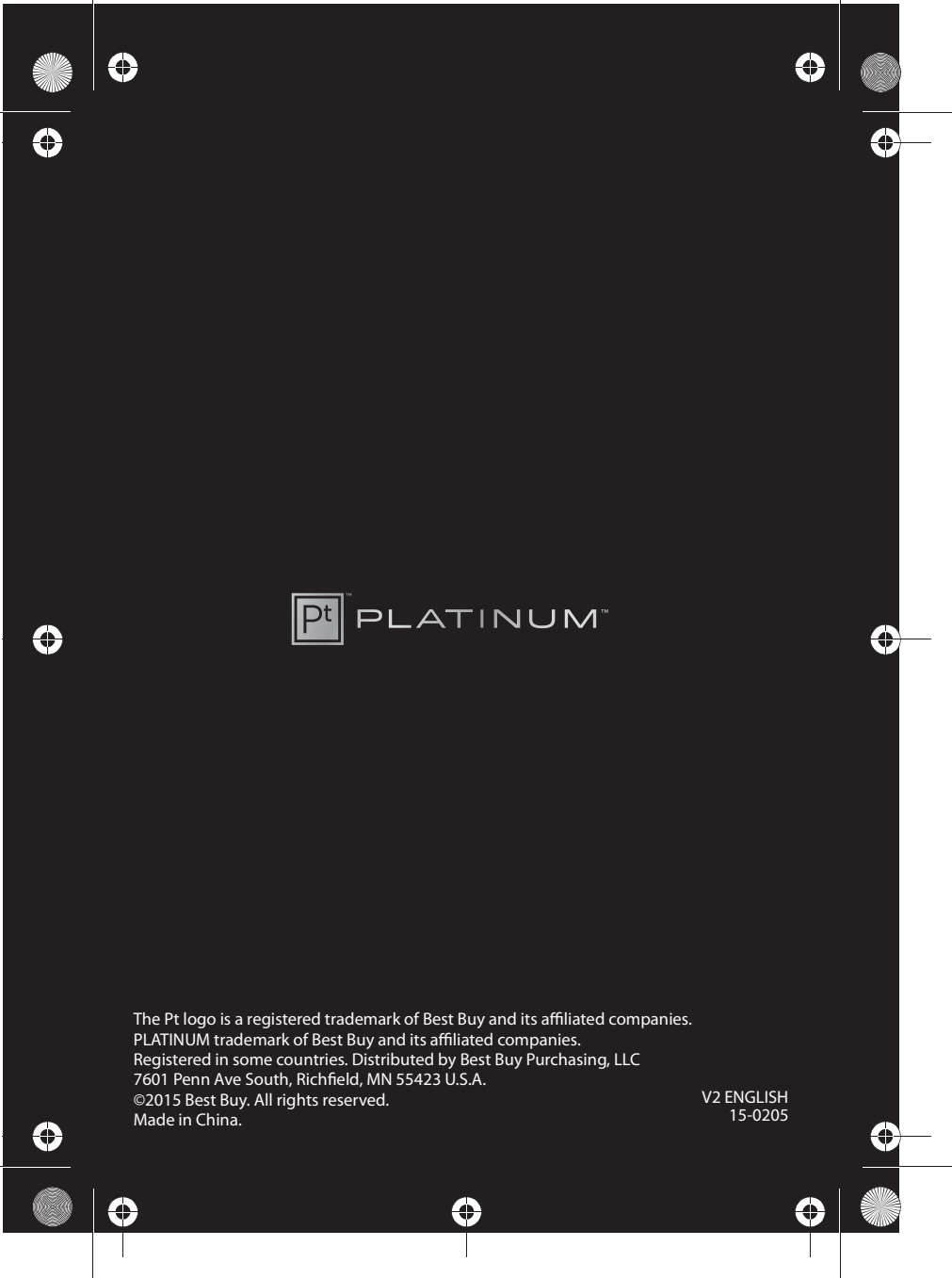

Pt PLATINUM™

The Pt logo is a registered trademark of Best Buy and its affiliated companies.
PLATINUM trademark of Best Buy and its affiliated companies.
Registered in some countries. Distributed by Best Buy Purchasing, LLC
7601 Penn Ave South, Richfield, MN 55423 U.S.A.
©2015 Best Buy. All rights reserved.
Made in China.

V2 ENGLISH
15-0205