

Features

VR4285HF

- Built-in VCR Plus Recording with Cable Box Control p. 12-1
- MTS Hi-Fi Stereo 2nd Audio Play/Record p. 13-2
- Bilingual (English-Spanish) Menus On-Screen Display p. 4-2
- Multi-Brand Zenith Remote Control MBR4285 p. 3-1
- Jog/Shuttle Remote Control Playback Options p. 7-3
- Message Center Displays p. 5-2
- Index Search p. 7-2
- On-Screen Programming p. 4-1
- On-Screen Display p. 5-1
- 1 Year, 8 Event Timer p. 9-1, 10-2
- Instant Recording p. 8-1, 10-1
- 181 Channel Capability
- Auto Channel Search p. 4-3
- Auto Digital Picture Tracking p. 7-2
- Quick Start Loading p. 7-1
- Auto Head Cleaner p. 14-3
- Auto Playback System p. 7-1
- Auto Counter Reset p. 7-1
- Auto Tape Speed Switching p. 13-1
- Counter Memory p. 13-1
- Auto Daylight Savings Adjust p. 13-1
- VCR Flashback p. 3-3
- HQ Circuitry
- All VCR features subject to change without prior notice.

VR4285HF



Video Cassette Recorder Operating Guide and Warranty







WARNING

**RISK OF ELECTRIC SHOCK
DO NOT OPEN**



WARNING: TO REDUCE THE RISK OF ELECTRIC SHOCK DO NOT REMOVE COVER (OR BACK). NO USER SERVICEABLE PARTS INSIDE. REFER TO QUALIFIED SERVICE PERSONNEL.

TO PREVENT FIRE OR SHOCK HAZARDS, DO NOT EXPOSE THIS PRODUCT TO RAIN OR MOISTURE.

The lightning flash with arrowhead symbol, within an equilateral triangle, is intended to alert the user to the presence of uninsulated "dangerous voltage" within the product's enclosure that may be of sufficient magnitude to constitute a risk of electric shock to persons.

The exclamation point within an equilateral triangle is intended to alert the user to the presence of important operating and maintenance (servicing) instructions in the literature accompanying the appliance.

Safety Tips

Refer to the "Safety Tips" booklet that came with your product for important safety considerations.

Note to Cable TV System Installer

This reminder is provided to call the cable TV system installer's attention to Article 820-40 of the NEC that provides guidelines for proper grounding and, in particular, specifies that the cable ground shall be connected to the grounding system of the building, as close to the point of the cable entry as practical.

Power-Cord Polarization

This product is equipped with a polarized alternating-current line plug (a plug having one blade wider than the other.) This plug will fit into the power outlet only one way. This is a safety feature. If you are unable to insert the plug fully into the outlet, try reversing the plug. If the plug should still fail to fit, contact your electrician to replace your obsolete outlet. Do not defeat the safety purpose of the polarized plug by altering it in any way.

CAUTION

TO PREVENT ELECTRIC SHOCK, MATCH WIDE BLADE OF PLUG TO WIDE SLOT, FULLY INSERT.

ATTENTION

POUR ÉVITER LES CHOCS ÉLECTRIQUES, INTRODUIRE LA LAME LA PLUS LARGE DE LA FICHE DANS LA BORNE CORRESPONDANTE DE LA PRISE ET POUSSER JUSQU'AU FOND.

REGULATORY INFORMATION

This equipment has been tested and found to comply with the limits for a Class B digital device, pursuant to Part 15

of the FCC Rules. These limits are designed to provide reasonable protection against harmful interference in a residential installation. This equipment generates, uses and can radiate radio frequency energy and, if not installed and used in accordance with the instructions, may cause harmful interference to radio communications. However, there is no guarantee that interference will not occur in a particular installation. If this equipment does cause harmful interference to radio or television reception, which can be determined by turning the equipment off and on, the user is encouraged to try to correct the interference by one or more of the following measures:

- Reorient or relocate the receiving antenna.
- Increase the separation between the equipment and receiver.
- Connect the equipment into an outlet on a circuit different from that to which the receiver is connected.
- Consult the dealer or an experienced radio/TV technician for help.

CAUTION: Do not attempt to modify this product in any way without written authorization from Zenith Electronics Corporation. Unauthorized modification could void the user's authority to operate this product.

This class B digital apparatus meets all requirements of the Canadian Interference-Causing Equipment Regulations.

"Cet appareil numérique de la class b respecte toutes les exigences du Règlement sur le matériel brouilleur du Canada."

CONTENTS

ii General Information

Introduction. Installation Considerations.

1 Installation/Step A

VCR Setup Checklist.

Connections with antenna or a cable box.

Audio/Video and accessories connections.

Front Audio/Video IN Connections.

Ch3-4 Switch.

2 VCR Front Panel Controls

Overview of VCR buttons. VCR Accessories.

3 MBR4285 Remote Control

Simple instructions for using Remote.

Installing Batteries; ready Remote to operate VCR etc.

Programming Remote Control Brand Codes.

Remote Control Key Descriptions.

4 VCR Features Setup/Step B

Personalize VCR On-screen Menus before playing or recording tapes.

5 VCR/TV Displays

VCR Display on TV screen.

VCR Message Center Displays.

6 Watching TV

TV Antenna In Connections.

TV Audio/Video In Connections.

Overview of three tuning options.

TV Tuning, VCR Tuning, Cable Box Tuning.

7 Playing Tapes (Playback)

Playing pre-recorded tapes.

Recording/Playing Tapes Times Chart.

Playback Options.

Playback Shuttle Operation.

Playback Jog Operation.

8 Instant Recording

Recording what you see on your TV screen.

9 Timer Recording

Recording while you are away (VCR turned off.)

10 Recording with a Cable Box

Recording Cable TV (CATV) subscriber programming that requires a cable/converter box.

Recording what you see on your TV screen.

Timer Recording broadcasts with a cable box.

11 VCR Plus Recording

Recording using VCR Plus.

Recording using VCR Plus, with a cable box.

12 VCR Plus Recording Setup/Step C

Setting up the VCR to record using VCR Plus.

Setting up the VCR to record VCR Plus with cable/converter box. Channel Mapping.

13 Additional Information

AUX Channel.

Index Search.

Real-Time Tape Counter.

Special Menu.

—Auto Clock Set.

—Auto Daylight Savings Adjustment.

Auto Tape Recording Speed Switching.

Audio Record Mode.

Audio Playback Mode.

VCR+ Recording Setup Double Channel Mapping.

14 Service Information

Resolving operating difficulties.

Video heads and cabinet cleaning.

System Overview—VCR, TV and Cable Box.

15 VCR Features Chart

VCR Features Listing.

Your Sears Warranty

Warranty coverage for your VCR.

This product is exclusive to and warranted solely by Sears. Refer to back cover for specific warranty information.

Notes: All VCR features, graphics and identification labeling are subject to change without prior notice.

GENERAL INFORMATION

Congratulations on buying a **VHS** Video Cassette Recorder (VCR). For your convenience, please read these simple instructions before operating your VCR.

NOTES:

- This Video Cassette Recorder is compatible with any video cassette bearing the mark **VHS**.
- **VHS** is designed to expand your opportunities for in-home TV viewing and not for any usage which might violate copyright laws.
-  The Video Cassette Recorder (VCR) with this marking incorporates **VHS** high-quality picture technology and is compatible with any Video Cassette Recorders bearing the **VHS** mark.

Installation Considerations

Before you install your VCR...



Ventilation — Proper ventilation keeps your VCR running cool. Air circulates through perforations in the back and bottom of the cabinet. Do not block these vents or you will shorten the life of your VCR.



Power Source — Your VCR is designed to operate on normal household current, 120 volt 60 Hertz AC. Do not attempt to operate it on DC current.



Power Cord — Your VCR power cord has a polarized plug as required by Underwriters' Laboratories. It has one regular blade and one wide blade and fits only one way into a standard electrical outlet. If the blades will not enter either way, your outlet is very old and non-standard. A new outlet should be installed by a qualified electrician.



Safe Operation — Your VCR is manufactured and tested with your safety in mind. However, unusual stress caused by dropping or mishandling, exposure to flood, fire, rain or moisture, or accidental spilling of liquids into the VCR, can result in potential electrical shock or fire hazards. If this happens, have your VCR checked by a service technician before using it again.

Please read and observe each safety point in the "Safety Tips" folder when installing and using your VCR.

- **Plugging in Your VCR** — Be sure to plug your VCR into an "unswitched" AC power source. The "switched" AC outlets found on some video equipment will not continue supplying power to the VCR once the equipment is turned off. If the power to the VCR is interrupted for an extended time, you will have to reset the clock in the VCR.
- Keep the video recorder and video cassette away from strong magnetic fields.
- Use only approved and recommended accessory units with your video recorder to avoid potential hazards.
- Save the shipping carton and packing material. They will come in handy if you ever have to ship your video recorder. For maximum protection, re-pack the video recorder as it was originally shipped from the factory.

Moisture condensation is apt to occur under the following conditions:

- When the video recorder is moved from a cold place to a warm place.
- Under extremely humid conditions.

In locations where moisture condensation may occur:

- Keep the power cord plugged into an AC outlet and the POWER switch set to ON. This will help prevent condensation from occurring.
- When condensation has occurred, it will not evaporate quickly once the power is switched on. Wait a few hours for the video recorder to become dry before using the video recorder.

INSTALLATION/Step A

VCR Setup Checklist

Step A Connect Cables to System Components

- 1. Make equipment connections to VCR, (see the following pages in this section.)
- 2. Plug all system components into household current (120V AC-Line Outlet).

Step B VCR Features Setup (Personalize On-Screen Menus)

Set up VCR Features for your particular system, (see VCR Features Setup section.)

- 1. (Optional) Specify **Spanish** for On-Screen Menus.
- 2. Set the VCR Clock.
- 3. Perform Auto Channel Search.
- 4. (Optional) Specify, **ADD** or **DEL** (Delete) in Channel Scan.

Step C VCR Plus Recording Setup

- 1. Set up **VCR Plus** and **Channel Map** for your local broadcast area, (see VCR Plus Setup section.)

Once Steps A, B and C are complete, your VCR is ready to use.

(See System Operations in Service Information section.)

Notes to above steps:

- You can change the on-screen menu system, so it appears in Spanish instead of English.
- The VCR clock must be set before attempting to record using the VCR timer.
- Auto Channel Search registers the channels you receive; numerically. You can then customize your channel scanning selection with the optional Channel ADD/DELETE Procedure. You can specify if a particular channel should be omitted or included (added/deleted) when scanning channels.
- If you move or change equipment connections to the VCR, redo the channel search.
- You must complete the VCR Plus Setup procedure, before you can record using the VCR Plus feature.
- You must channel map for your local broadcast area, or the program you record may be from a different channel than the one you intended.
- System Operations describes Cable Box, VCR and TV operations within a system.

Note: If a power failure occurs and lasts for over 15 minutes, you may have to reprogram the VCR features.

INSTALLATION/Step A

Connections

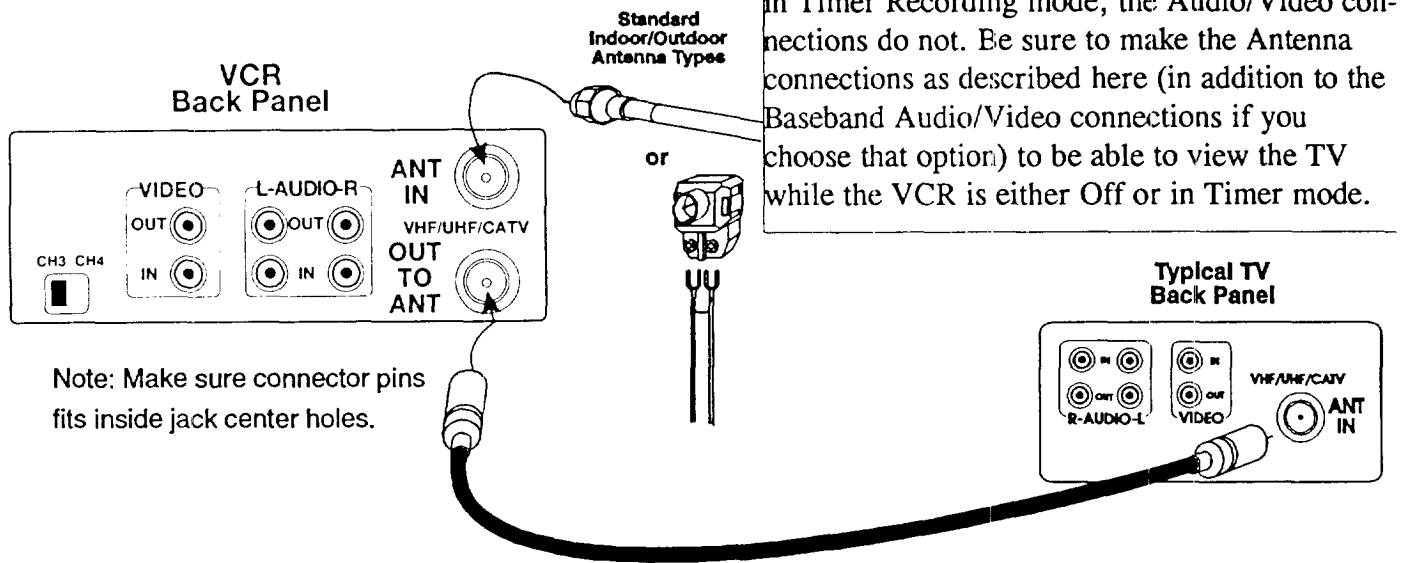

Step 1. Connect your antenna type or CATV cable to VCR ANT IN.

Step 2. Connect Hook-up Cable from VCR OUT TO ANT to TV Ant In.

Step 3. Set CH3-4 Switch on VCR back panel to CH3.

Connections with a Cable Box

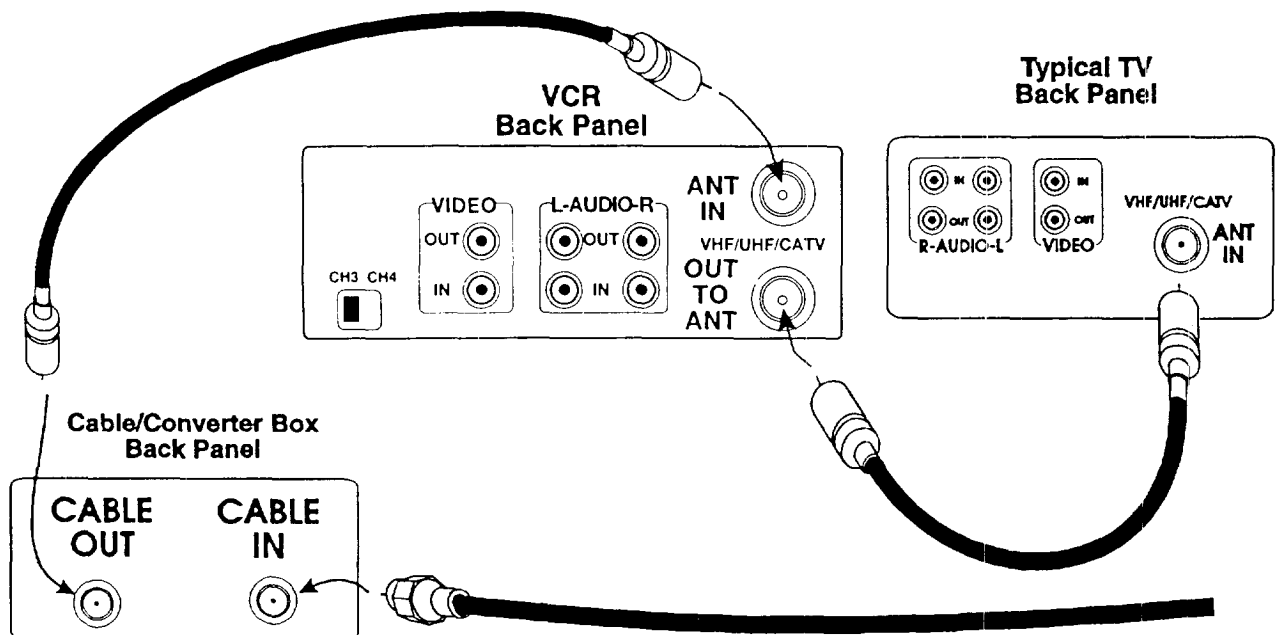

Step 1. Connect CATV Cable to Cable In.

Step 2. Connect Cable Out to VCR ANT IN.

Step 3. Connect Hook-up Cable from VCR OUT TO ANT to TV Ant In.

Step 4. Set CH3-4 Switch on VCR back panel to CH3.

INSTALLATION/Step A

Audio/Video Connections (To TV A/V In Jacks)

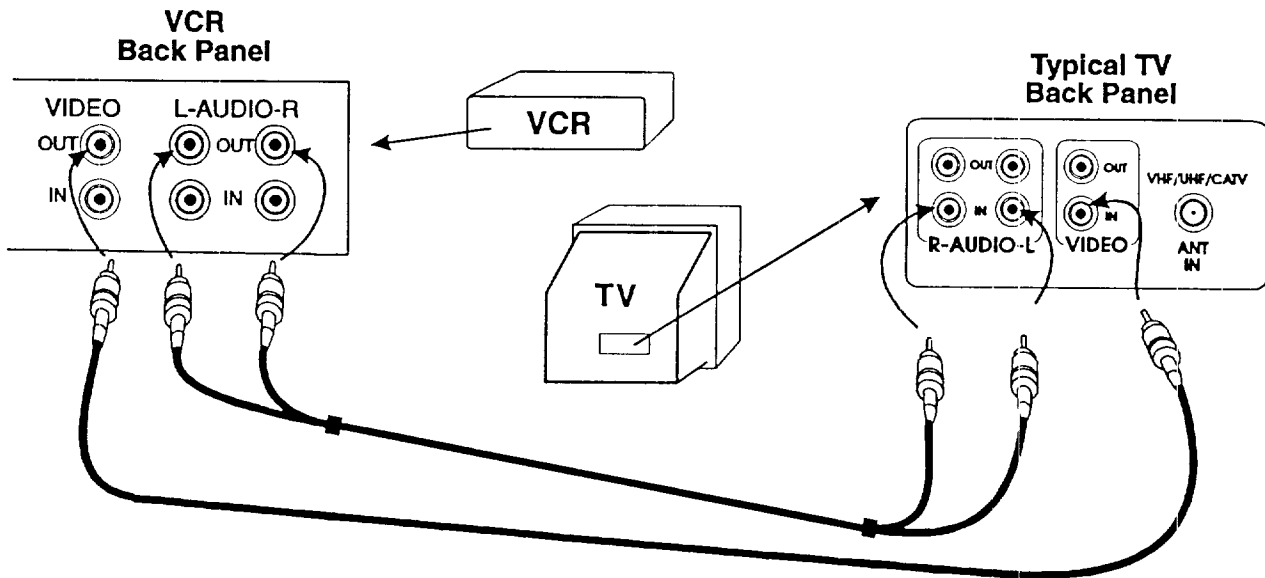

Note: You must make these additional connections to hear stereo sound while playing a tape or using the VCR Tuner as the source of the TV picture. See Additional Information.

Step 1. Connect VCR L-AUDIO-R OUT to Audio Right and Left In jacks on the TV or a stereo.

Step 2. Connect VCR VIDEO OUT to the Video In jack on the TV.

Accessories Audio/Video Connections (To VCR A/V In Jacks)

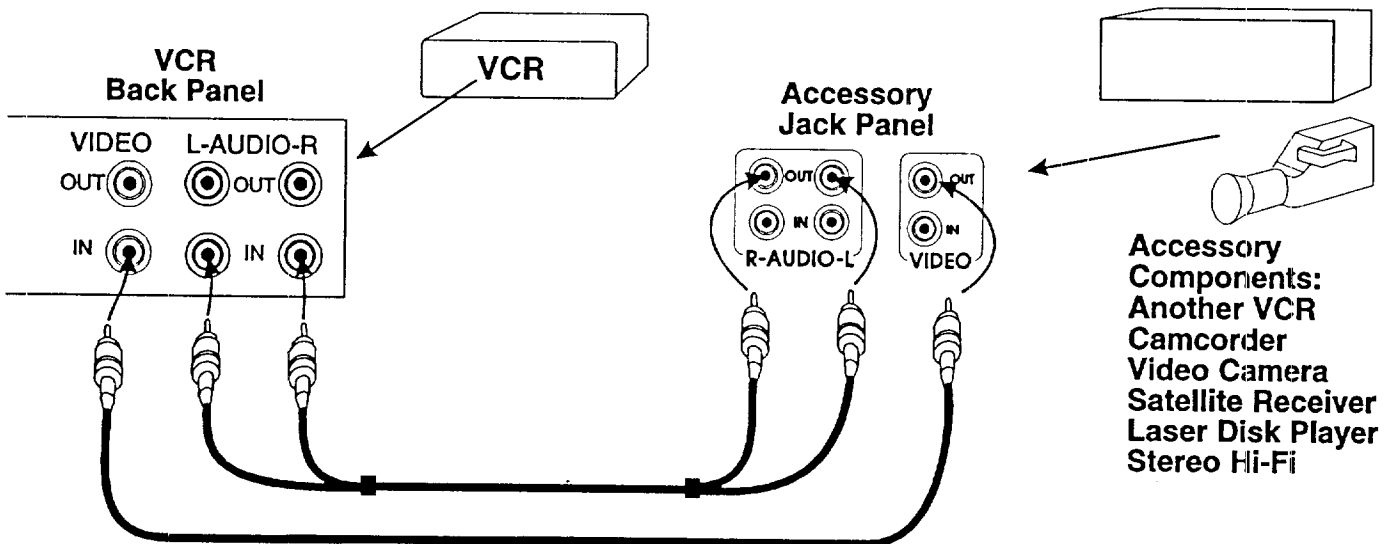

Step 1. Connect Audio Right and Left Out Cables from an audio source, such as another VCR, Camcorder, Satellite Receiver, Laser Disk Player or Stereo Hi-Fi, to the VCR L-AUDIO-R IN jacks.

Step 2. Connect Video Out from a video source to the VCR VIDEO IN jack.

Note: If you need adapters or additional audio/video cables to make the connections shown in this section, they can be purchased from your nearest Sears Retail Store or Service Center.

INSTALLATION/Step A

VCR Front Audio Video (In) Connections (Behind Door)

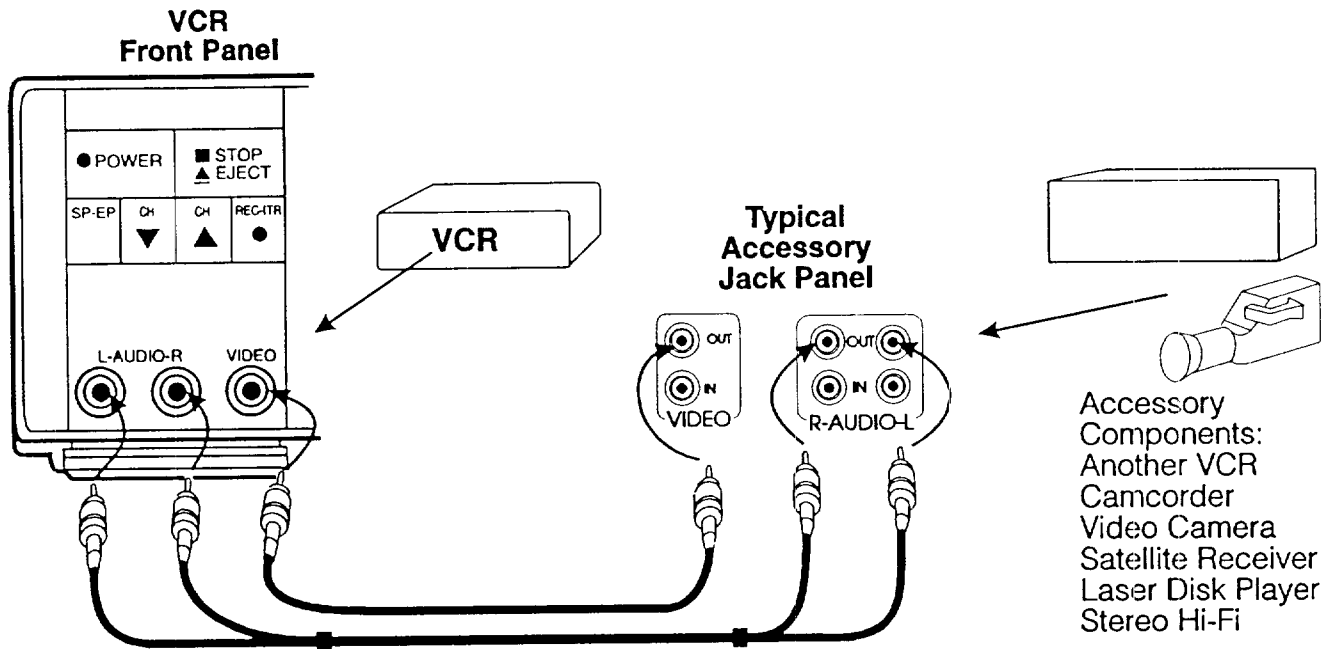

Use the VCR front L-AUDIO-R/VIDEO (In) jacks for easy connection when using an accessory component temporarily. The accessory component, connected to the VCR FRONT L-AUDIO-R/VIDEO (In) jacks, will override the component connected to the VCR REAR L-AUDIO-R/VIDEO IN jacks.

VCR CH3-4 Switch (Works with TV Antenna In Connections Only)

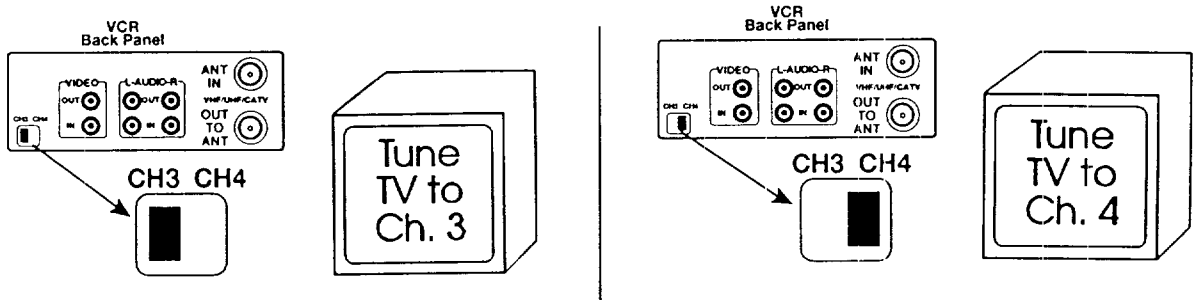

VCR CH3-4 Switch - This switch sends the signal produced by the VCR to the TV set over Channel 3. **ALL SYSTEM OPERATIONS (VCR Tuning, Playback, Recording, Timer Recording etc.) WILL HAVE TO BE PERFORMED WITH THE TV TUNED TO CHANNEL 3.** (Before the TV can receive an image sent from the VCR, while the VCR is On, the TV must be On and tuned to Channel 3. TV/VCR SOURCE Switch set to VCR, so VCR appears in Message Center.)

If Channel 3 does not work, set the Ch3-4 switch to Ch- 4. **ALL SYSTEM OPERATIONS (VCR Tuning, Playback, Recording, Timer Recording etc.) WILL THEN HAVE TO BE PERFORMED WITH THE TV TUNED TO CHANNEL 4.** (Before the TV can receive an image sent from the VCR, while the VCR is On, the TV must be On and tuned to Channel 4. TV/VCR SOURCE Switch set to VCR, so VCR appears in Message Center.)

VCR FRONT PANEL CONTROLS

VCR Front Panel

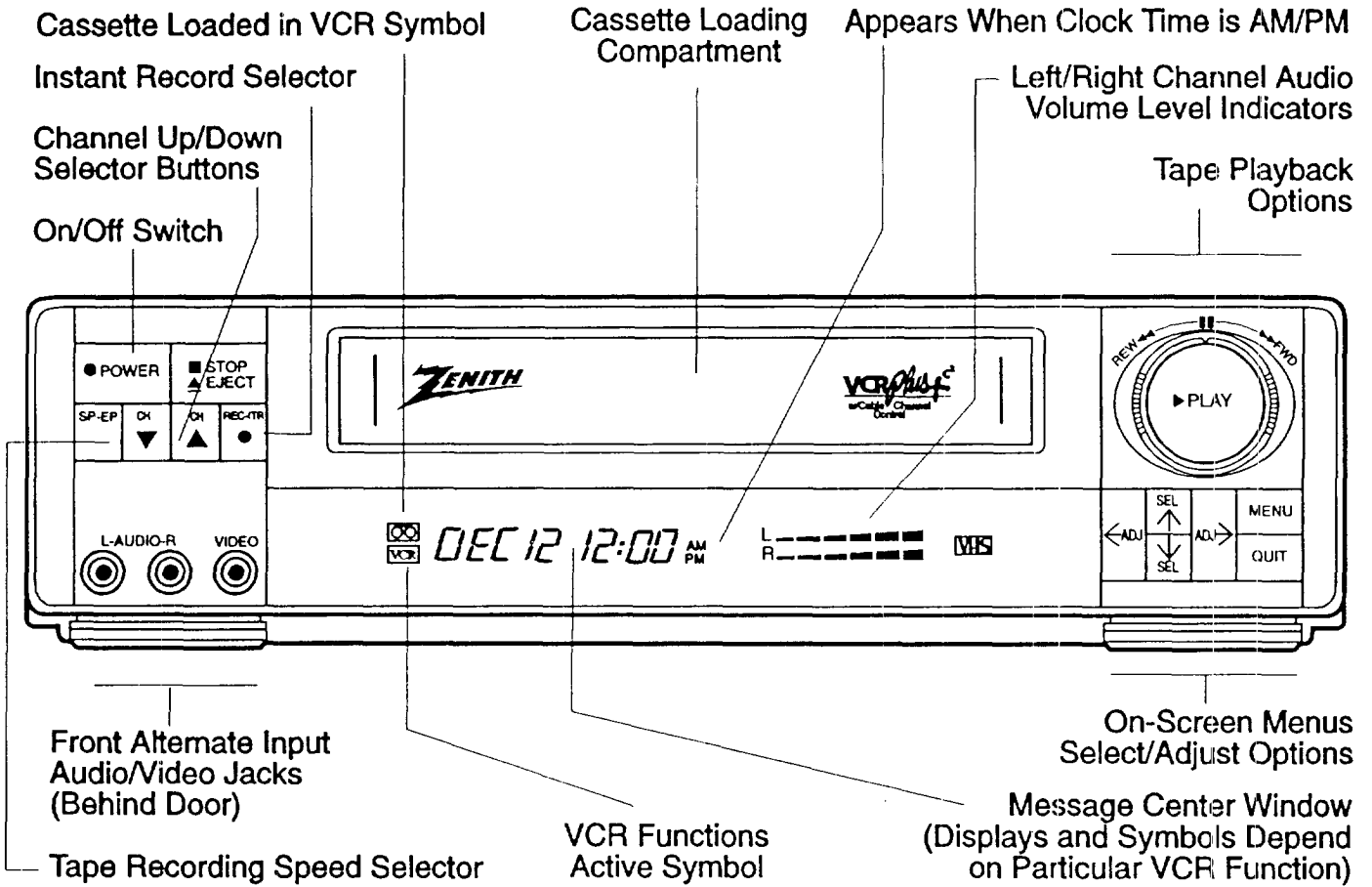

Operate your VCR using the front panel buttons or remote control keys.

VCR Accessories

Remote Control

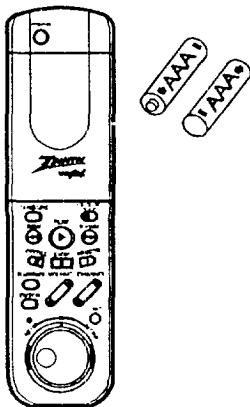

Hookup Cable

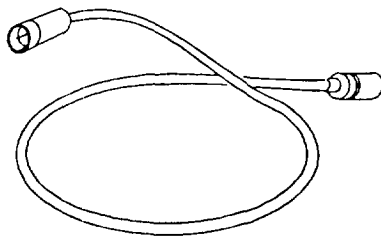

Audio/Video Cables

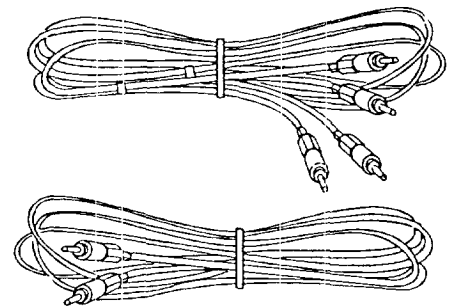

REMOTE CONTROL MBR4285

Using Remote

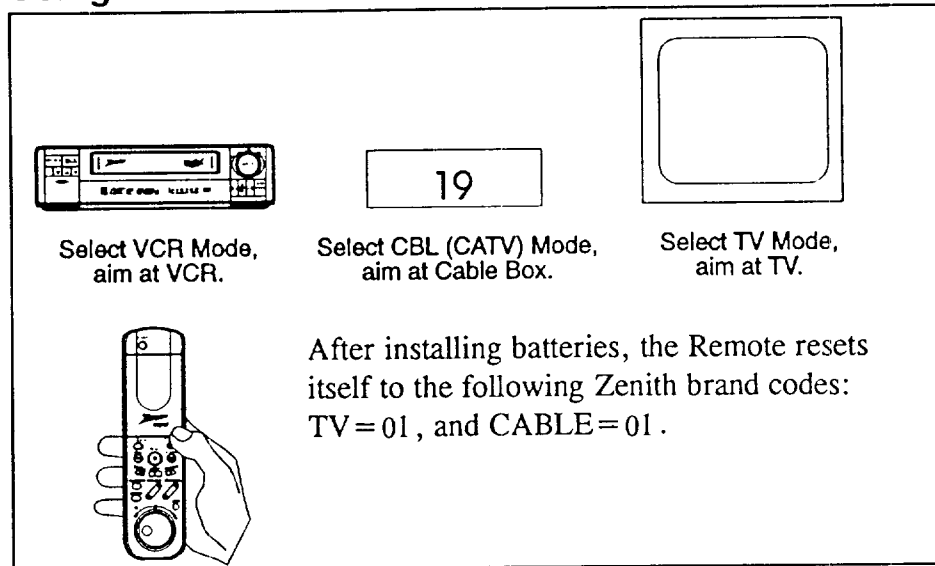

Select VCR Mode, aim at VCR.

Select CBL (CATV) Mode, aim at Cable Box.

Select TV Mode, aim at TV.

After installing batteries, the Remote resets itself to the following Zenith brand codes:
TV = 01, and CABLE = 01.

In Addition to Your VCR, use Remote Control to Operate Other Equipment

To program Remote to operate most remote controlled TVs and cable boxes, look up your units' brand code numbers on the Remote Control Brand Codes page. Write numbers in below.

TV Code(s)

CABLE Code(s)

1. Slide mode switch to desired mode —TV or CBL (Cable).

2. Press and hold down **PROGRAM**.

Press the numbered keys for your brand. (For example, press 01 for Zenith.) Release **PROGRAM**, Code should be installed.

TV Mode

0-9 number keys, Channel Up/Down and Volume Up/Down will be active.

Cable Mode

0-9 Numbered keys and Enter key will be active.

Notes: If batteries are removed it may be necessary to reprogram the Remote for proper brand codes for your equipment. If you do not use the CBL (CATV) mode on the Remote to operate a cable box, CBL (CATV) mode can be used to operate another TV.

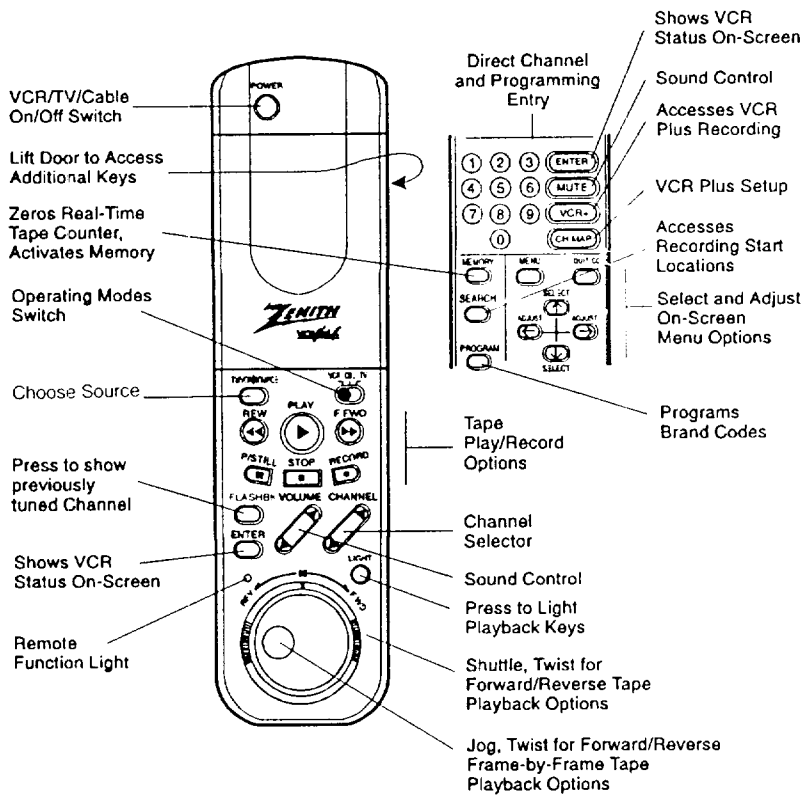

Installing Batteries

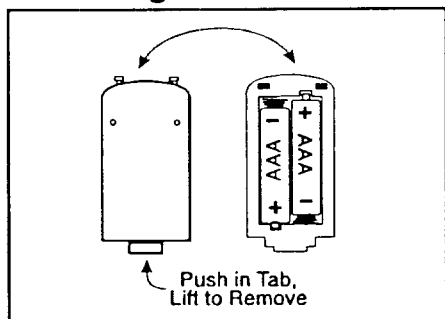

Batteries are provide with Remote but must be installed. Match positive with positive (+ with +), match negative with negative (- with -).

REMOTE CONTROL MBR4285 BRAND CODES

TV BRAND CODES

NO.	TV BRAND
01	ZENITH
02	CENTURION, CURTIS-MATHIS, DAYTRON, GOLDSTAR, J.C.PENNEY, SAMPO, NEC, MGA/MITSUBISHI, SCOTT, SYLVANIA, WARDS, MAGNAVOX
03	CORONADO, EMERSON, GOLDSTAR, KMC, PHILCO, PORTLAND, SHARP, TEKNIKA, HITACHI, WARDS, MAGNAVOX, KTV
04	SONY
05	RCA, GENERAL ELECTRIC
06	PANASONIC, QUASAR, GENERAL ELECTRIC
07	TOSHIBA, SEARS
08	SANYO, FISHER, SEARS

CATV (CABLE/CONVERTER BOXES) BRAND CODES

NO.	CATV BRAND
01	ZENITH, VIDEOWAY
02	OAK
03	OAK
04	OAK
05	OAK, VIEWSTAR, EAGLE, MAGNAVOX, PHILIPS
06	GEMINI, JERROLD, GI, SAMSUNG, SLMARX, TELEVIEW, STARGATE
07	GEMINI
08	PANASONIC, RCA, SAMSUNG, SLMARX, SPRUCER, TELEVIEW, STARGATE
09	ARCHER, CABLEVIEW, CITIZEN, GOBRAND, PULSER, UNIKA
10	REALISTIC
11	GE
12	CURTIS, ATLANTA
13	CURTIS, ATLANTA
14	CURTIS, ATLANTA
15	VIEWSTAR, EAGLE, MAGNAVOX, PHILIPS
16	VIEWSTAR, EAGLE, MAGNAVOX, PHILPS
17	VIEWSTAR, EAGLE, MAGNAVOX, REGAL
18	VIEWSTAR, EAGLE, MAGNAVOX
19	VIEWSTAR, EAGLE
20	VIEWSTAR, EAGLE
21	JERROLD, GI
22	JERROLD, GI
23	JERROLD
24	JERROLD, GI
25	JERROLD, GI
26	JERROLD, GI

REMOTE CONTROL MBR4285 KEY DESCRIPTION

ADJUST, ADJ— Use to change options when programming.

CHANNEL— Press top or bottom of key to choose next or previous channel.

CH MAP— (Channel Map) Press to begin channel mapping procedure.

ENTER— Use to exit any on-screen menu, and Direct Channel Entry.

FLASHBACK— Press to return to channel previously selected with VCR Tuner.

F FWD— (Fast Forward) Use to advance tape.

FWD— (Forward) Twist playback Shuttle in this direction to begin forward tape movement.

JOG— Twist toward FWD or REV to Advance/Reverse tape playback, one frame at-a-time.

LIGHT— Press to light VCR Play/Record function keys.

MEMORY— Press to access Memory feature and zero Real-Time Tape Counter.

MENU— Press to display on-screen menus.

MUTE— Press to turn off sound, press again to restore sound.

Numbered Keys— Use to choose channels or input programming information.

POWER— Use to turn VCR on and off.

PLAY— Press to begin playing tape (playback).

PROGRAM— Press to begin brand code programming procedure.

P/STILL— (Pause/Still) Press to freeze tape playback or record, press again to resume. Use to activate playback Shuttle options.

QUIT/CC— (Quit/Closed Captions) Use to exit any on-screen menu, and to access Closed Captions (CaptionVision) if available on your TV.

RECORD— Use to begin tape recording.

REV— (Reverse) Twist playback Shuttle in this direction to begin reverse tape movement.

REW— (Rewind) Use to rewind tape.

SEARCH— Use to access an Index recording start location.

SELECT, SEL— Use to choose options when programming.

SHUTTLE— Use for variable speed Forward/Reverse Playback options.

STOP— Press to halt tape.

TV/VCR SOURCE— Use to choose source of TV picture (VCR functions or TV Tuner.)

VCR CBL TV— Slide to choose operating mode for Remote Control (VCR, Cable or TV.)

VCR+— Press to begin VCR plus recording.

VOLUME— Use to increase or decrease sound level.

On-Screen and Remote Control Arrows

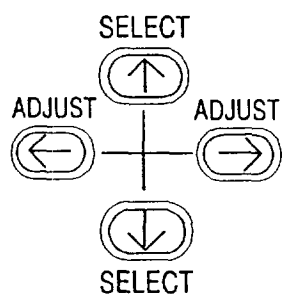

On Remote

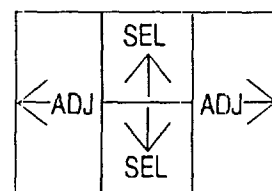
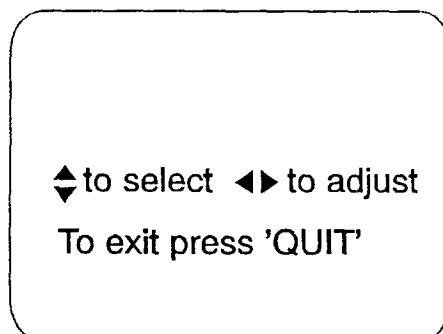

On VCR

Note: Where arrows appear within on-screen menus, use the keys shown to Select and Adjust options.

VCR FEATURES SETUP/Step B

Overview: VCR Features On-Screen Menus and Submenus

To set up VCR features see following pages.
 Perform steps in order as instructed, 1, 2, 3, etc.,
 to set up each feature.

The example below shows how to use Remote Control
 to access on-screen menus.
 Press **MENU** to access on-screen menus.
 Use **up/down/left/right** arrows to select and adjust
 VCR options.

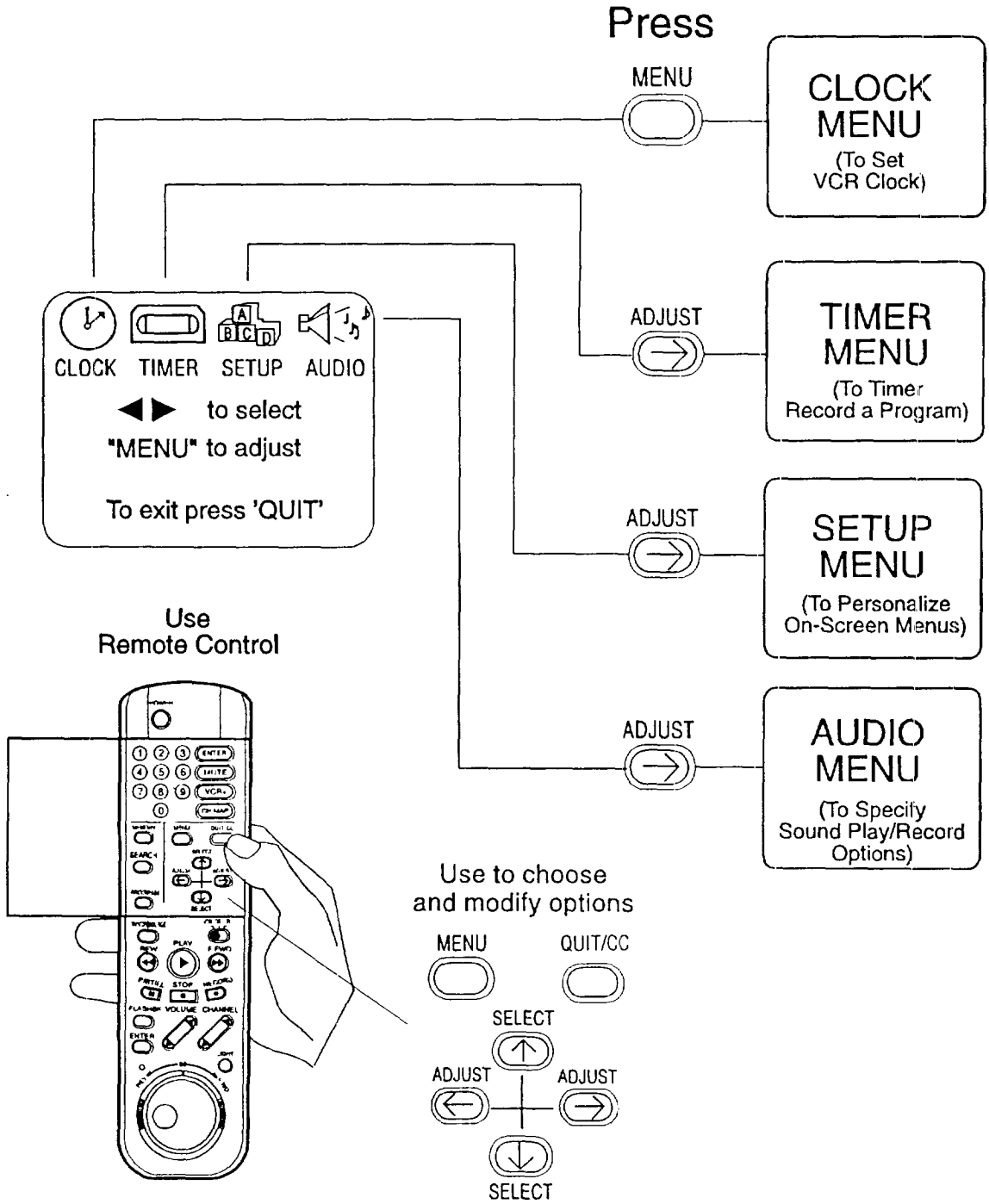

VCR FEATURES SETUP/Step B

Features Setup Requirements

TV and VCR on.

TV tuned to Channel 3 or set up with the TV Audio/Video In Jacks as the source of the TV picture.

TV/VCR SOURCE Switch on remote control set at VCR. (VCR symbol appears in VCR Message Center window.)

Features Setup Requirements with a Cable Box.

TV, VCR and Cable Box On.

TV tuned to Channel 3 or set up with the TV Audio Video In jacks as the source of the TV picture. VCR tuned to Cable Box output channel number 2, 3, 4, 5 or 6.

TV/VCR SOURCE Switch on remote control set at VCR. (VCR symbol appears in VCR Message Center window.)

(Optional Language Select) Specifying Spanish for On-Screen Menus

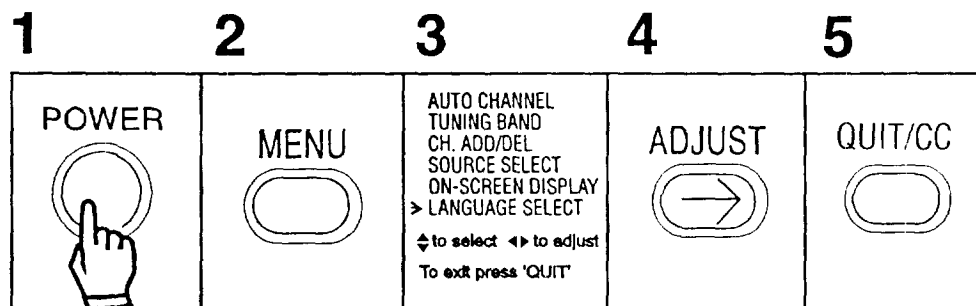

Step 1. Turn VCR on.

Step 2. Press **MENU**. Press **ADJUST** Left/Right repeatedly to choose **SETUP**, press **MENU**.

Step 3. Press **SELECT** down arrow repeatedly to choose **LANGUAGE SELECT**.

Step 4. Press **ADJUST** Left/Right to choose Spanish.

Step 5. Press **QUIT** when finished.

To Select English Menus

Step 1. Turn VCR on.

Step 2. Press **MENU**. Press **ADJUST** Left/Right repeatedly to choose **PRE**, press **MENU**.

Step 3. Press **SELECT** down arrow repeatedly to choose **IDIOMA**.

Step 4. Press **ADJUST** Left/Right to choose **INGLÉS**.

Step 5. Press **QUIT** when finished.

Specifying Tuning Band ---- TV or CATV

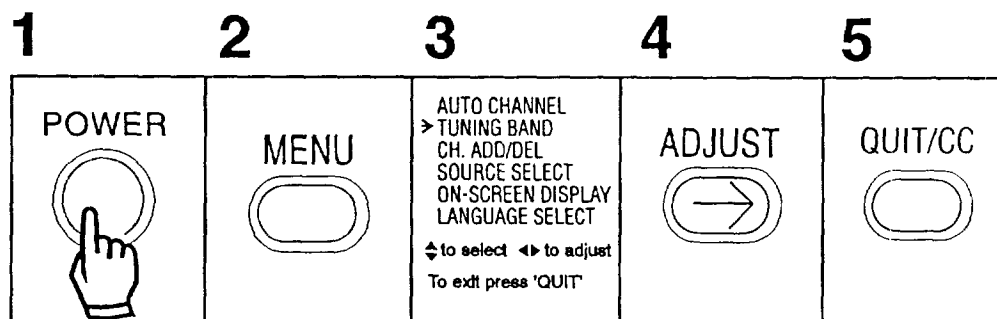

Step 1. Turn VCR on.

Step 2. Press **MENU**. Press **ADJUST** Left/Right repeatedly to select **SETUP**, press **MENU**.

Step 3. Use **SELECT** Up/Down arrows to choose **TUNING BAND**.

Step 4. Use **ADJUST** Left/Right arrows to choose **TV**, for an antenna, or **CATV** if you subscribe to cable service.

Step 5. Press **QUIT** when finished.

VCR FEATURES SETUP/Step B

Using Auto Channel (Search), VCR saves available channels in memory

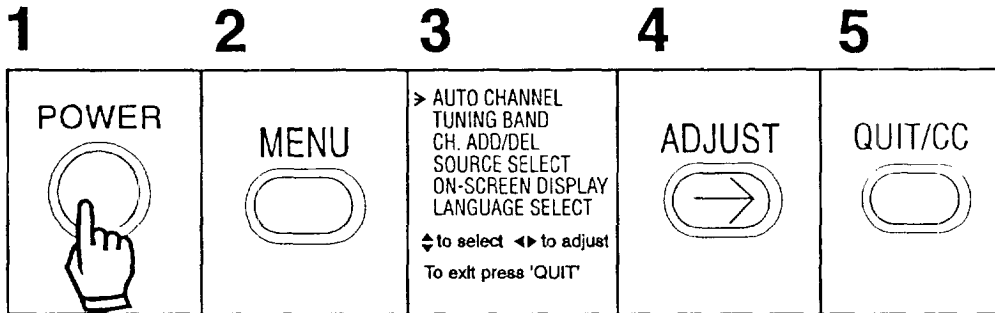

Step 1. Turn VCR on.

Step 2. Press **MENU**. Press **ADJUST** Left/Right repeatedly to choose **SETUP**, press **MENU**.

Step 3. Use **SELECT** Up/Down arrows to choose **AUTO CHANNEL**.

Step 4. Press **ADJUST** to begin search.

Step 5. Press **QUIT** when search is finished.

(Optional) Using Channel Scan Add or Delete Procedure

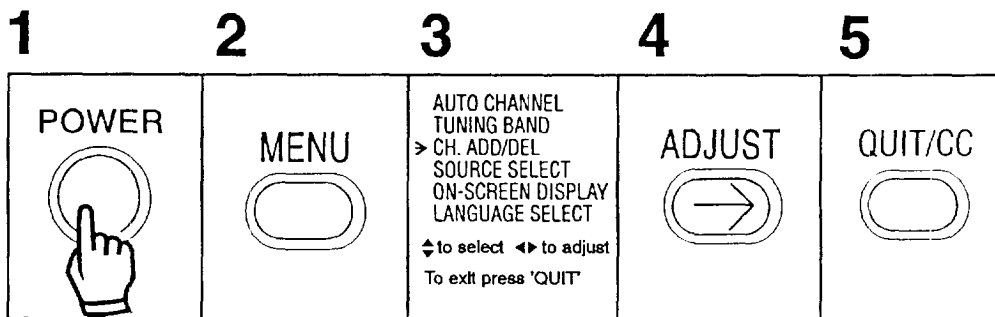

Step 1. Turn VCR on.

Step 2. Press **MENU**. Press **ADJUST** Left/Right repeatedly to choose **SETUP**, press **MENU**.

Step 3. Press **SELECT** Up/Down arrows to choose **CH ADD/DEL**.

Step 4. Use numbered keys to choose channels and **ADJUST** Left/Right to choose **ADD** or **DEL**.

Step 5. Press **QUIT** when finished.

VCR FEATURES SETUP/Step B

Setting The VCR Clock

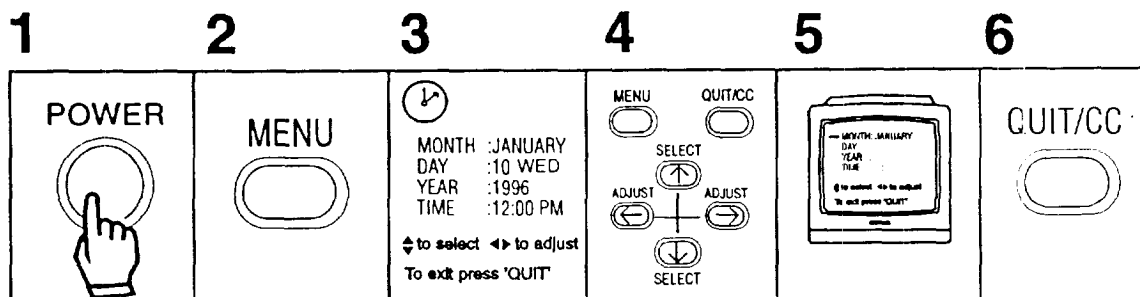

Use to choose
and modify options

Step 1. Turn VCR on.

Step 2. Press **MENU**.

Step 3. Press **MENU**.

Step 4-5. Use **SELECT** Up/Down arrows and **ADJUST** Left/Right arrows to choose and specify current time. For example: Use **SELECT** Up/Down arrows to choose MONTH position, use **ADJUST** Left/Right arrows to choose current month, **JANUARY**, **FEBRUARY**, **MARCH** etc. Use **SELECT**

Up/Down arrows to choose **DAY** position, use **ADJUST** Left/Right arrows to choose current date.

Use **SELECT** Up/Down arrows to choose TIME position. Use numbered keys or **ADJUST** Left/Right to choose current time and AM or PM as appropriate. etc.

Step 6. Press **QUIT** when finished.

Note: This VCR can automatically adjust the clock for Daylight Savings Time.

Setting Other Menu Options

Use the following method to choose and specify on-screen menu options for your particular VCR.

Step 1. Turn VCR on.

Step 2. Press **MENU**. Press **ADJUST** Left/Right repeatedly to choose desired on-screen option from the **CLOCK**, **TIMER**, **SETUP** or **AUDIO** menus. Use **SELECT** and **ADJUST** keys to modify desired options.

Step 3. Press **QUIT** when finished.

All features listed below may not be available on your VCR. Check the VCR Features listed for your particular VCR.

See **ADDITIONAL INFORMATION** for descriptions of the following features.

On-Screen Display

—On/Off

Special Menu

—Auto Clock Set (On/Off Adjustment)

—Auto Daylight Savings (On/Off Adjustment)

(For these options only, press **MENU** to show Main Menu. Press **4567** to access Special Menu.

Press **QUIT** when finished.)

Audio Record Mode

—Stereo/Monaural/2nd Audio

Audio Playback Mode

—Hi-Fi/Normal

Aux Channel

—Using Accessory Components

Source Select

—Tuner/Aux

VCR/TV DISPLAYS

Your VCR is controlled by both the remote control and the buttons on the VCR. Some VCR functions can be initiated by both units, but mostly the remote control must be used.

Notes: For all operations both the VCR and TV power should be ON. To control the VCR, the remote control should be in VCR mode.

VCR On-Screen Display

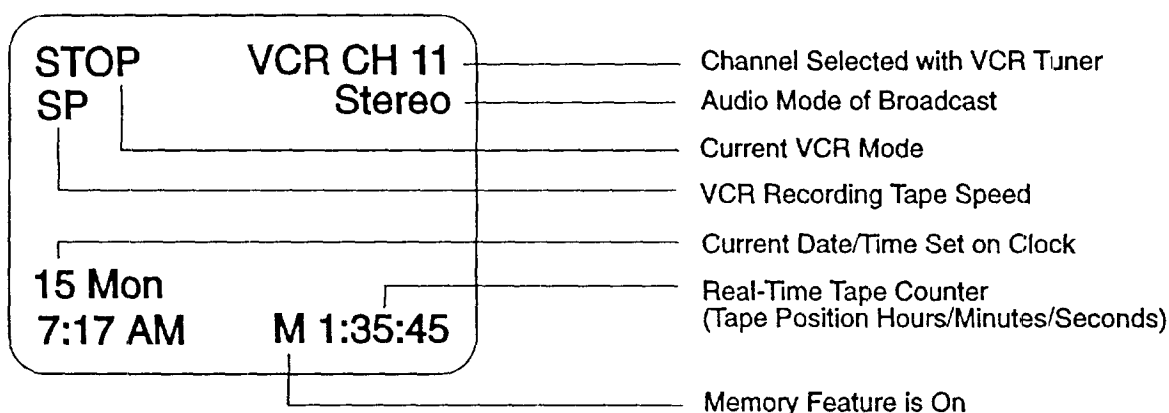

The VCR On-Screen Display appears on the TV screen when a VCR function starts, like changing a channel or selecting a different VCR mode. For example, pressing **STOP** while VCR is in **PLAY** mode.

Press **ENTER** to show VCR On-Screen Display on TV screen.

Press **ENTER** again to leave Real-Time Tape Counter position display on TV screen.

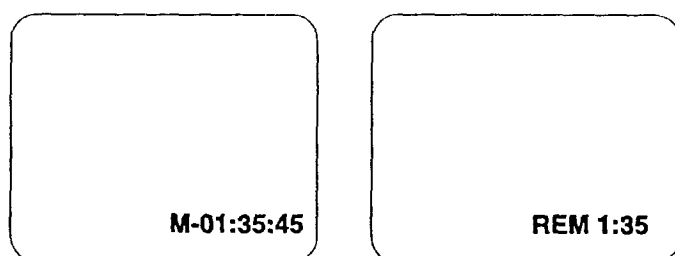

Press **ENTER** a third time to leave Tape Time Remaining display on TV screen. (REM indicates the time left on the video tape in the VCR—1:35 means one hour and thirty-five minutes are left on the video tape.)

Press **ENTER** repeatedly to remove all displays.

Note:

If the VCR On-Screen Display does not appear on your TV screen, do the following:

Step 1. Press **MENU**. Press **ADJUST** repeatedly to choose **SETUP**, press **MENU**.

Step 2. Use **SELECT** Up/Down arrows to choose **ON-SCREEN DISPLAY**.

Step 3. Use **ADJUST** Left/Right arrows to specify **ON**.

Step 4. Press **QUIT**.

VCR MESSAGE CENTER DISPLAYS

VCR Message Center and On-Screen Displays



The current function of the VCR is detailed on the TV screen and in the VCR Message Center/Clock area of the VCR.

Information displayed in the VCR Message Center will depend on the VCR function. If the Clock displays **SET CLOCK** then there has been a power failure, or the power cord has been disconnected.

You may have to reprogram the VCR.

Clock/Message Center - As a VCR function starts, the VCR Message Center displays the function. For example, when you press **REW**, (rewind) the VCR Message Center will read **REWIND** and the VCR On-Screen Display, which appears on the TV screen, will briefly show **REWIND**. Clock remains on even while VCR is off.

Setup Messages

SET CLOCK — VCR Clock has not been set.
Press **MENU** twice, follow-screen instructions.

Tuner Messages

HELLO — VCR has been turned on.
ADDED 3 — Channel 3 has been added.
DELETED 7 — Channel 7 has been deleted.
CHANNEL _ — VCR tuned to Channel _.
AUX — Equipment connected to VCR
L-AUDIO-R /VIDEO IN is being played through VCR.

Playback Messages

PLAY — Tape is playing at normal playback speed.
PLAYX2 — Tape is advancing at twice normal playback speed.
-PLAYX3 — Tape is reversing at three times normal playback speed.
AUTO TRACK — VCR is adjusting tracking.
STOP — VCR is in Stop mode.
FFWD — (Fast Forward) Tape is advancing rapidly.
REW — (Rewind) Tape is rewinding rapidly.

FWD SEARCH — Tape is advancing rapidly in Playback mode.

REV SEARCH — Tape is reversing rapidly in Playback mode.

STILL — Playback mode has halted on one frame.

SLOW — Playback mode speed has been reduced.

Record Messages

REC AUX — (Recording AUX Channel) VCR is recording the signal sent by the system componer connected to VCR **L-Audio-R/Video In** front or rear jacks.

REC CH _ — VCR is recording Channel _.

RECORDING 1 — VCR is recording first Timer Recording assignment.

REC PAUSE — Record mode has halted.

TAPING DONE — All Timer Recording assignments have been completed.

TIMER SET — VCR is in **Timer** mode.

INDEX MARK — VCR is marking the start location of a recording.

MONO — VCR is receiving a **Mono** audio signal.

ST/2nd AUDIO — VCR is receiving **Stereo** and **2nd Audio** monaural audio signals.

STEREO — VCR is receiving a **Stereo** audio signal.

NO TAPE TAB — Can't record, Cassette Safety Tab is missing. Paste tape over safety tab hole.

NO CASSETTE — No cassette in VCR.

Tape Transport Messages

EJECT — VCR is ejecting tape.

ERROR — See authorized Sears Service Center.

Operating Indicators

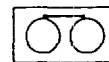

A cassette tape is loaded in the VCR.



VCR functions are active.

WATCHING TV (TV Antenna In Connections)

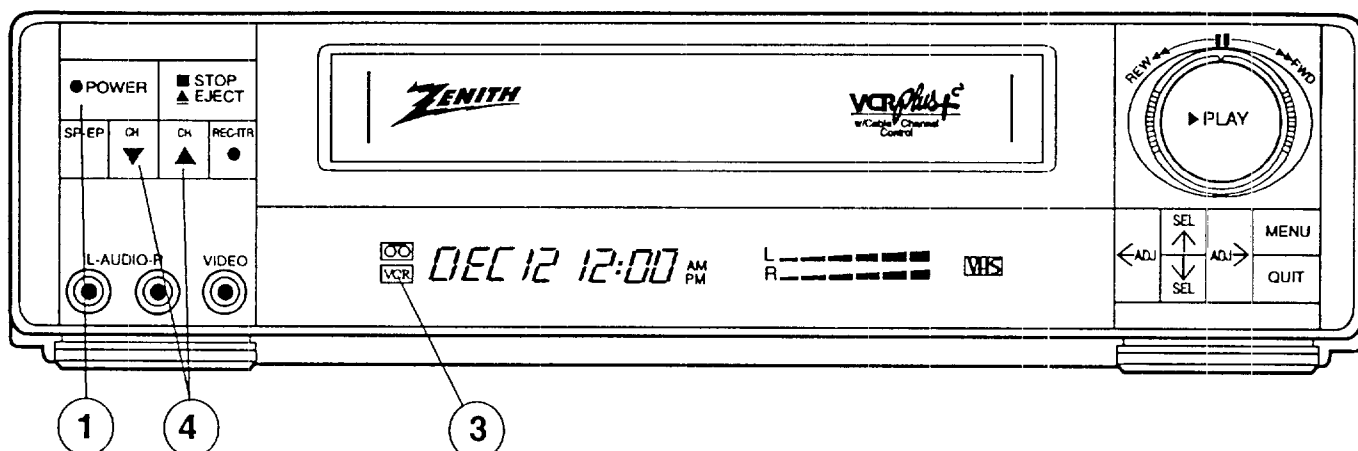

Note: This setup (Antenna In TV Connections) requires that the TV be tuned to the same channel that the VCR Ch3-4 Switch is set at, either Channel 3 or 4.

There are three tuning options available to you for selecting channels to watch on your TV. You can use the TV tuner, the VCR tuner, or the cable box itself (if you have a cable box.) (See Service Information chapter for System Operation Chart.)

TV Tuning

1. Turn TV and VCR on.
2. Switch Remote to VCR mode.
3. Switch TV/VCR SOURCE to TV, to turn off VCR indicator in VCR Message Center.
4. Switch Remote to TV mode. Select channels with Remote or TV controls. Note: Remote will operate most Zenith TVs.

VCR Tuning

1. Turn TV and VCR on, tune TV to Channel 3.
2. Switch Remote to VCR mode.
3. Switch TV/VCR SOURCE to VCR, VCR indicator appears in VCR Message Center.
4. Select desired channel with Remote or VCR Channel Up/Down.

Cable Box Tuning

1. Turn TV, VCR and cable box on, tune TV to Channel 3.
2. Switch Remote to VCR mode. Tune VCR to your cable box output channel number; 2, 3, 4, 5 or 6.
3. Switch TV/VCR SOURCE to VCR, VCR indicator appears in VCR Message Center.
4. Tune cable box to desired channel number.

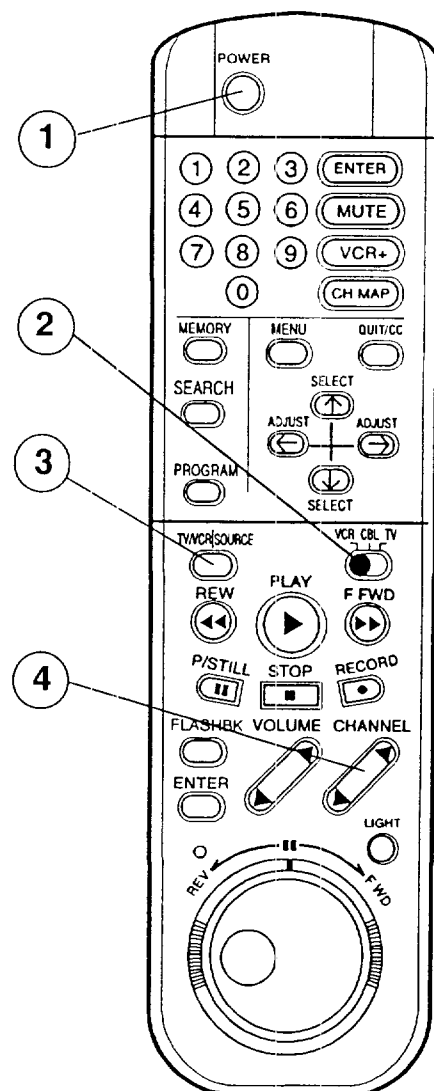

WATCHING TV (TV Audio/Video In Connections)

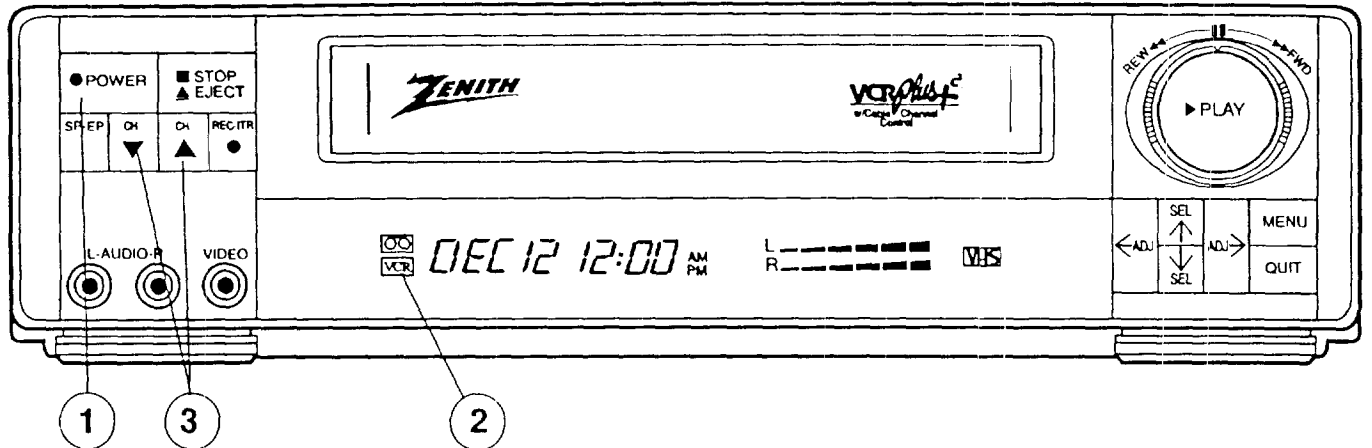

Note: This setup (Audio/Video In TV Connections) requires that the TV use the Audio/Video In jacks as the source of the TV picture.

There are three tuning options available to you for selecting channels to watch on your stereo TV. You can use the TV tuner, the VCR tuner, or the cable box itself (if you have a cable box). To hear stereo sound, use TV Audio/Video In as the source for the TV picture. (See Service Information chapter for System Operation Chart.)

TV Tuning

Follow instructions on previous page for TV viewing.

VCR Tuning

(Requires Audio/Video In jacks on TV)

1. Turn TV and VCR on, set TV to Audio/Video In source.
2. Switch Remote to VCR mode.
3. Select desired channel with Remote or VCR Channel Up/Down.

Cable Box Tuning

1. Turn TV, VCR and cable box on, set TV to Audio/Video In Source.
2. Switch Remote to VCR mode. Tune VCR to your cable box output channel number; 2, 3, 4, 5 or 6.
3. Tune cable box to desired channel number.

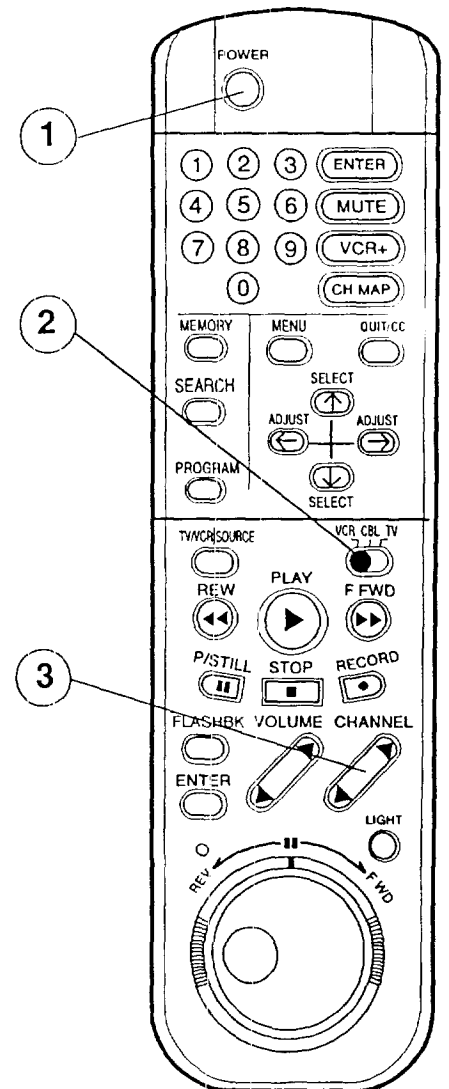

PLAYING TAPES (Playback)

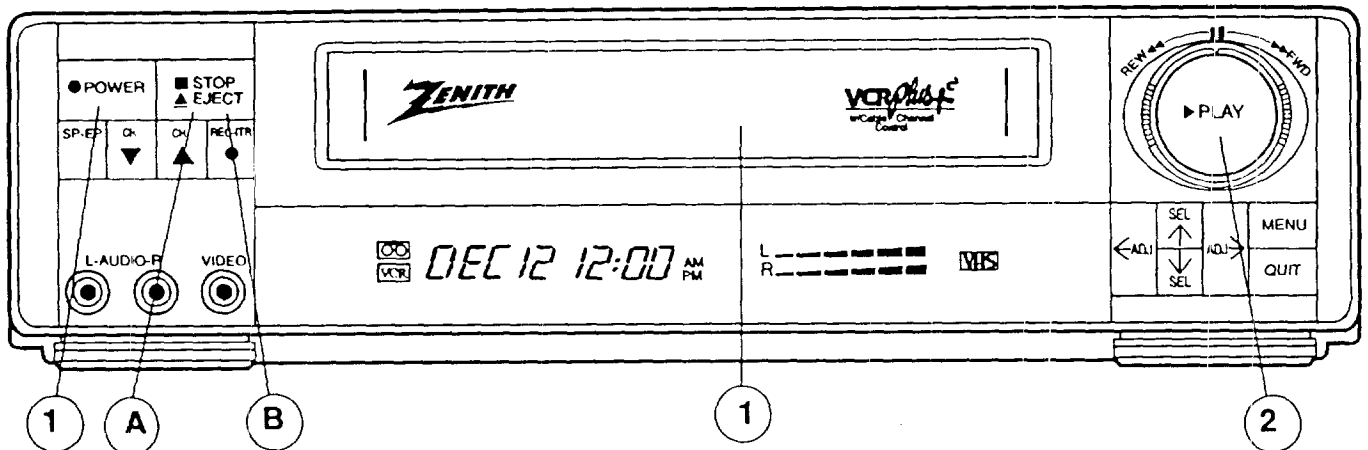

1. Press **POWER** to turn VCR on, or insert a prerecorded VHS cassette tape.
2. Press **PLAY**.

Cassette Length	SP	EP
	(Standard Play)	(Extended Play)
T-30	30 Minutes	1 Hour, 30 Minutes
T-60	1 Hour	3 Hours
T-120	2 Hours	6 Hours
T-160	2 Hours, 40 Minutes	8 Hours

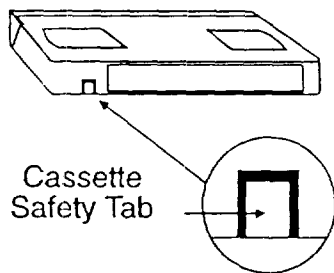

Auto Playback System

If the Cassette Safety Tab has been removed, the VCR will begin to play the tape automatically. (A Rental tape will often have the Safety Tab removed.)

Options

- A. Press **STOP** to stop playing tape.
- B. Press **EJECT** to eject tape.
- C. Real-Time Tape Counter

Press either **ENTER** key two times to leave the Real-Time Tape Counter display on the TV screen, press **ENTER** repeatedly to remove all displays.

(1:35:28 = 1 hour, 35 minutes and 28 seconds).

The counter resets to **0:00:00** when you insert a tape or when a tape is rewound to its beginning.

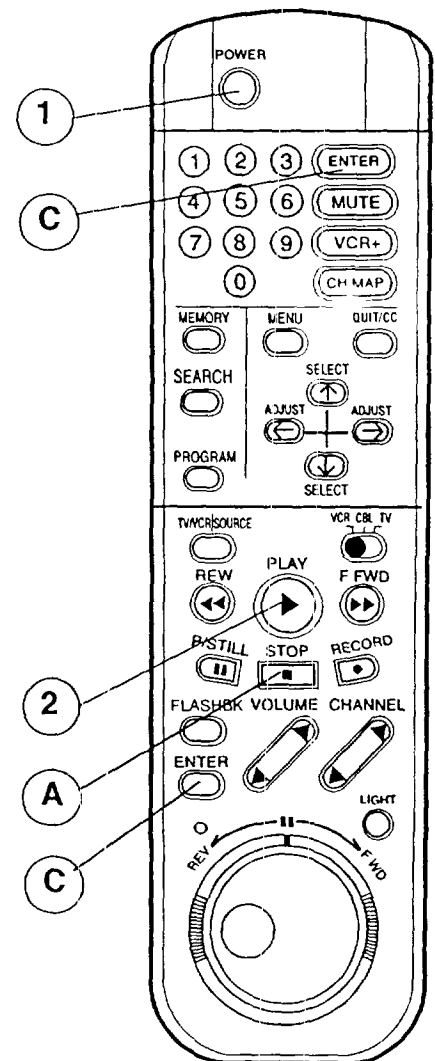

PLAYING TAPES (Playback Options)

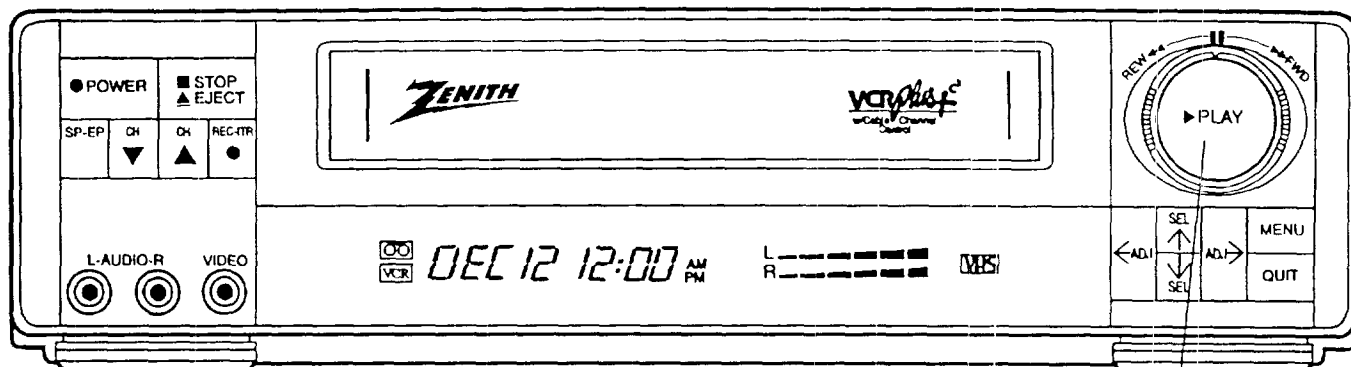

Use these controls

Playing Tapes Options

(See Remote Control and Additional Information Sections)

A. Pause Forward/Reverse Slow Motion Video

(While in *Play mode*) Press **PAUSE** twice, follow on-screen instructions for slow motion. Press **PLAY** to resume playing tape.

B. Tape Rewind/Fast Forward

(While in *Stop mode*) Press and release **REW** or **F FWD**. Press **STOP** when tape reaches desired location.

C. Reverse/Forward Search

(While in *Play mode*) Press and release **REW** or **F FWD**, and hold down **REW** or **F FWD** for Jet Search. Press **PLAY** to resume playing tape.

D. Tracking Adjustment Auto/Manual

Your Zenith VCR automatically adjusts tracking when you play a tape. If, however, the tape was recorded on a different VCR, streaks (video noise) may appear. While the tape is playing, press and hold down **ADJUST, ADJ** (Left/Right) to manually adjust the tracking.

E. Index Search

At the start of each recording an Index mark is inserted on the tape. Press **SEARCH**, then the number of the marks (1, 2, 3 etc.) that need to be passed to reach your desired recording start location, then press **F FWD** or **REW** as appropriate. Or, rewind the tape to the beginning and press the number of marks from the beginning of the tape that will get you to your recording start location, then press **F FWD**, the VCR advances the tape to that location and begins playback.

F. Memory

Use to zero Real-Time Tape Counter or turn on Memory feature. When Memory is active, tape (when rewound) will stop at the **M 0:00:00** position.

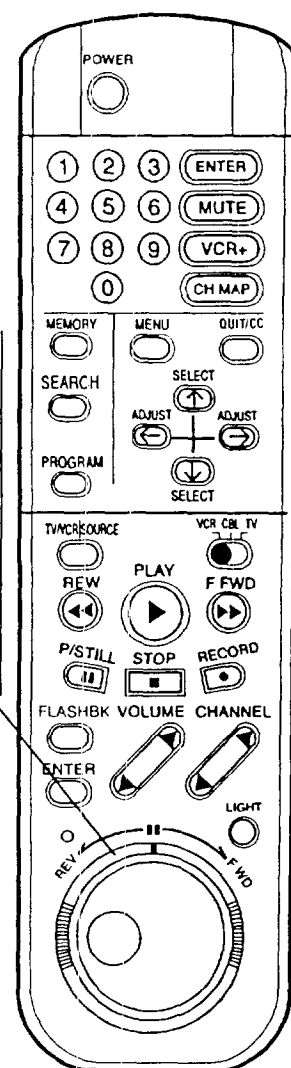

PLAYING TAPES (Playback Shuttle Operation)

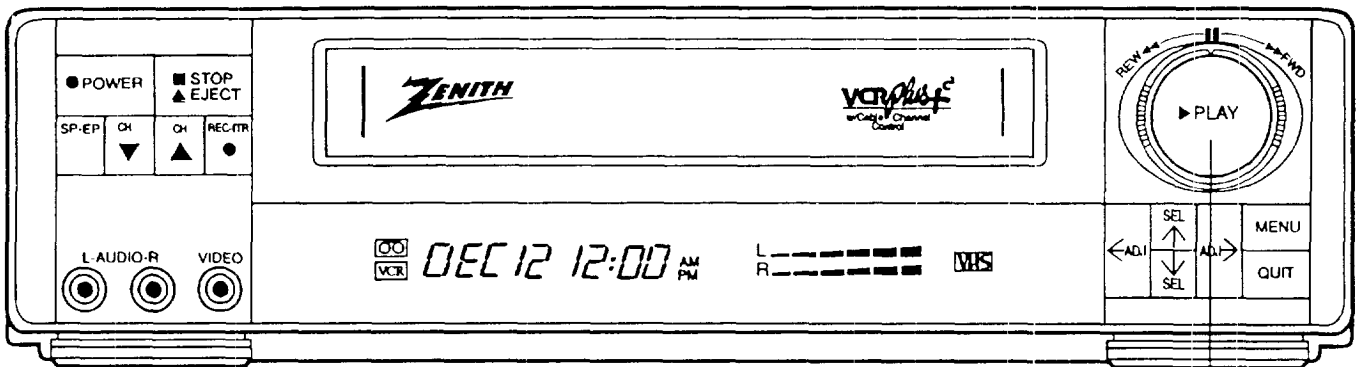

Use these controls

Playback Shuttle Options

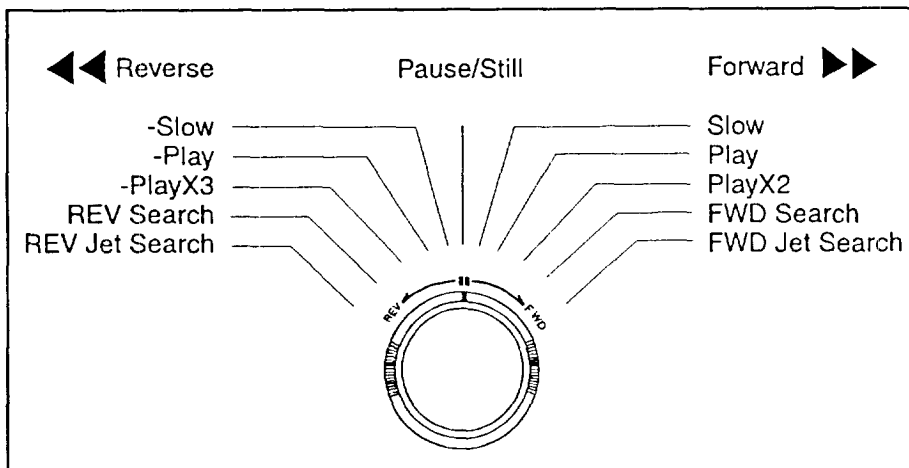

Press **P/STILL** for playback Pause mode.

Twist Shuttle toward **FWD** to advance the tape frame-by-frame. Twist Shuttle toward **REV** to reverse the tape frame-by-frame. How far you twist and hold the Shuttle determines the speed at which the tape will move, as indicated above. Release Shuttle to resume Pause/Still mode. Press **PLAY** to resume normal Playback speed.

Jog Shuttle Options

Press **P/STILL** for playback Pause mode. Move Jog with finger toward **FWD** to advance tape frame-by-frame, move toward **REV** to reverse tape frame-by-frame. One "click" equals one frame. How "fast" you move the Jog determines how fast the frame-by-frame movement occurs.

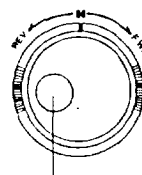

JOG, turn for frame-by-frame Forward/Reverse tape movement

Notes

- Not all the speeds shown will be displayed as they are selected in the VCR Message Center or on the VCR On-Screen Display.
- In Reverse Shuttle mode, some video noise may be present.
- Tapes recorded at SP (Standard Play) speed will playback better in Shuttle mode than tapes recorded at EP (Extended Play) speed.

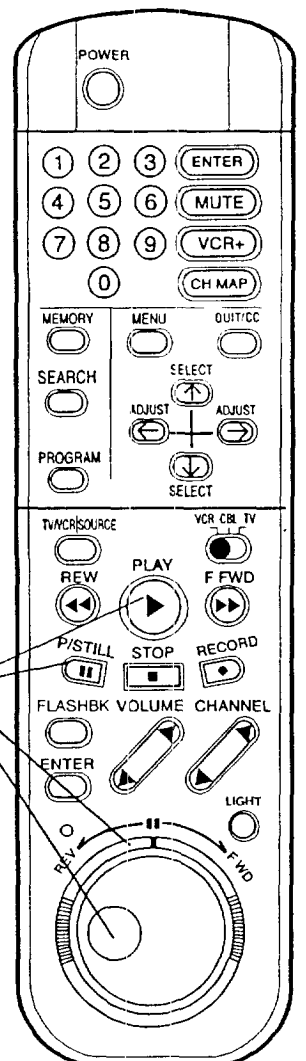

Use these controls

INSTANT RECORDING

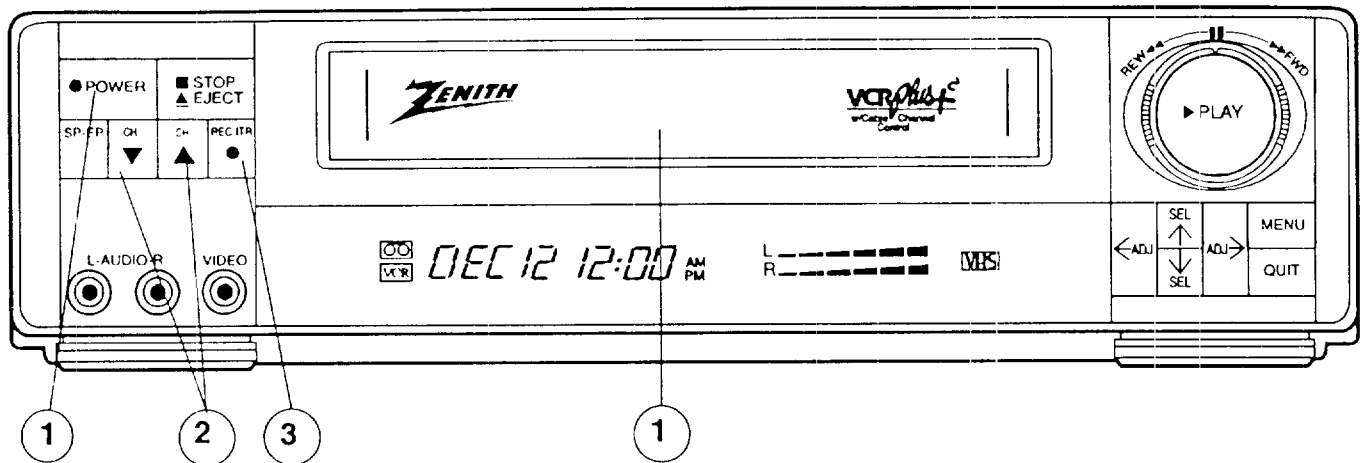

Recording What You See on Your TV Screen

1. Turn TV and VCR on, insert a VHS cassette tape.
2. Tune VCR to channel you wish to record.
3. Press **REC/ITR** or **RECORD**. Recording will continue until end of tape or until you cancel **Record**. Each press of **REC/ITR** or **RECORD** will increase recording time 30 minutes. Press **SP/EP** to choose recording speed. (See Playing Tapes for Recording/Playing Tapes Times Chart.)

Presses	On-Screen Display	Recording Time
1	12:20 (Current Time)	Until end of tape
2	0:30	30 Minutes
3	1:00	60 Minutes
4	1:30	1 Hour 30 Minutes
5-9	Etc. until Record time reaches 4:00	4 Hours Maximum

Recording Options

- A. Press **STOP** to stop recording. Press **EJECT** to eject tape.
- B. Press **REW** to rewind tape.
- C. Press **P/STILL** to momentarily cease recording.
Note: Pause mode only works with the first press of **RECORD** or **REC/ITR**. Once a recording time is selected, (second and third presses etc. of **RECORD** or **REC/ITR**) Pause mode will not be available.

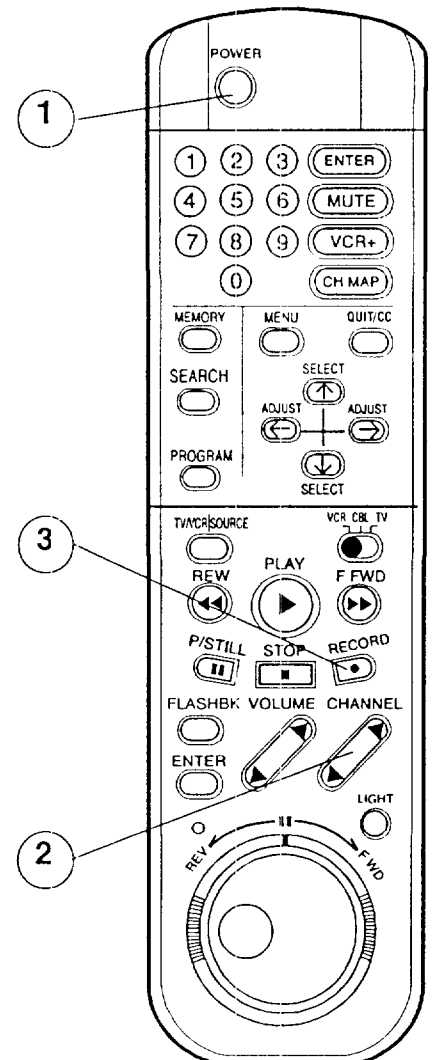

TIMER RECORDING

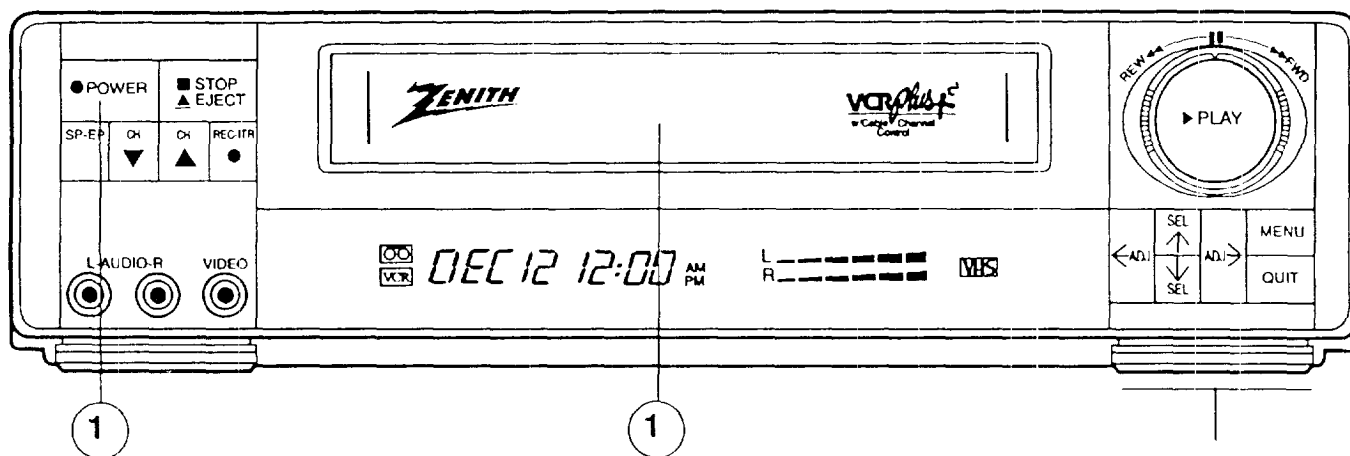

Use these buttons

Recording While You Are Away (VCR turned off)

1. TV and VCR on. Insert a VHS cassette tape.
2. Set Remote to VCR mode.
3. Press **MENU**, use **ADJUST** Left/Right to select **TIMER**, press **MENU**. Enter information for programs 1, 2, 3, etc. Use **SELECT**, **SEL** Up/Down, **ADJUST**, **ADJ** Left/Right and numbered keys to key-in programming information.
4. Press **QUIT** when finished, press **POWER** to turn VCR off and set VCR into Timer Recording mode.

Note: While VCR is operating in **Timer** mode it cannot be operated manually. If needed, press **POWER** to release VCR from **Timer** mode.

Timer Recording Options

Once— will record a broadcast one time.

Weekly— will record a broadcast one time each week.

Daily— will record a broadcast, one time each day, Monday through Friday.

Capability — Timer can be programmed to record eight different events.

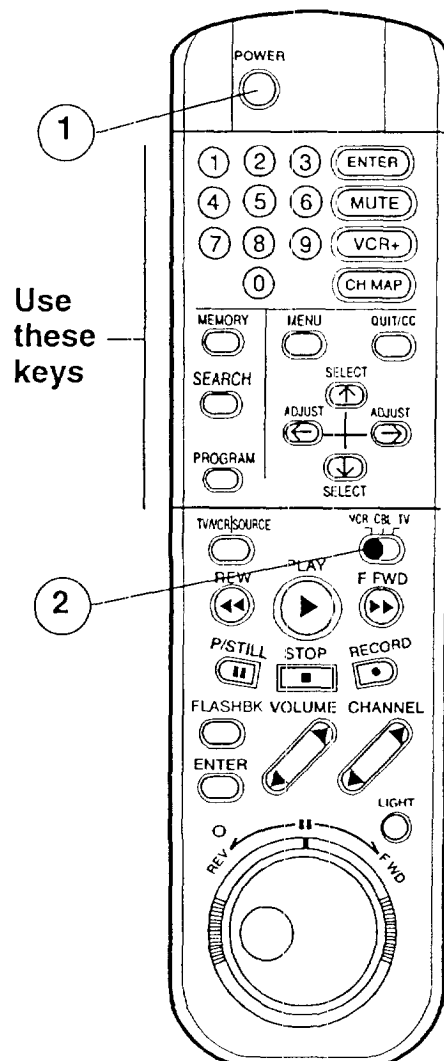

INSTANT RECORDING WITH A CABLE BOX

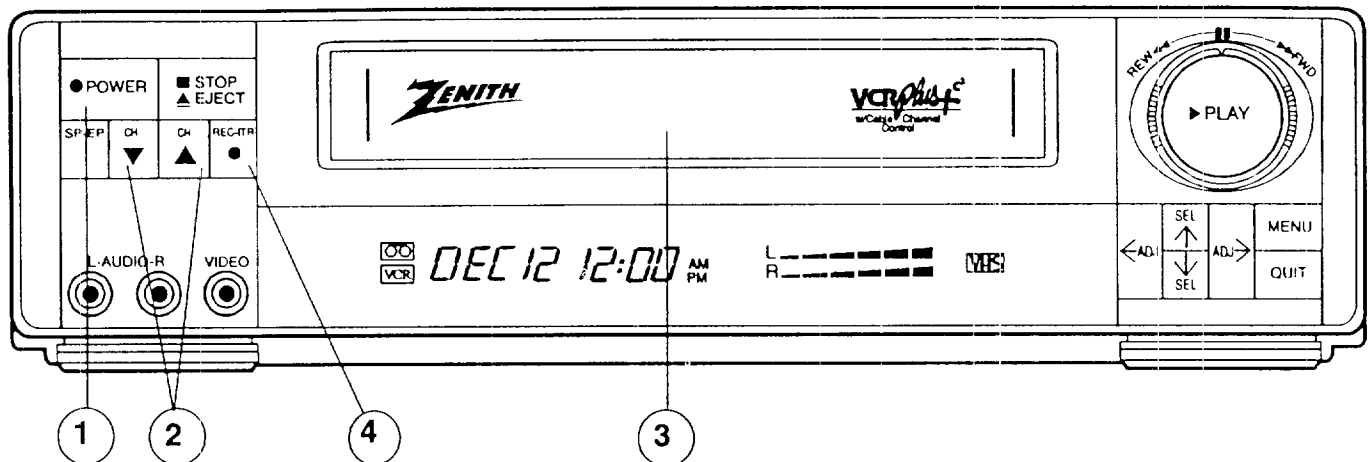

Recording Programs with a Cable Box (VCR turned on)

1. Turn TV and VCR on, tune VCR to cable/converter box output channel; 2, 3, 4, 5 or 6.
2. Turn cable/converter box on, tune to channel you wish to record and leave on.
3. Insert a VHS cassette tape.
4. Press and hold **REC-ITR** or **RECORD** until **RECORD** appears in VCR Message Center. Recording will continue until end of tape or until you cancel Record mode. Press **REC-ITR** or **RECORD** repeatedly to specify additional recording time. Each press of **REC/ITR** or **RECORD** will increase recording time 30 minutes. (See Instant Recording.)

Note: Recording Speed will be **SP**, press **SP/EP** to select **EP**, Extended Play. (See Recording/Playing Tapes Times Chart page 7-1.)

Options

- A. Press **STOP** to stop recording. Press **EJECT** to eject tape.
- B. Press **REW** to rewind tape.
- C. Press **P/STILL** to momentarily cease recording.
 Note: Pause mode only works for the first press of **RECORD** or **REC/ITR**. Once a recording time is selected, (second and third presses etc., of **RECORD** or **REC/ITR**) Pause mode will not be available.

Recording/Viewing Options

You can only watch what you are recording. Contact your cable company for their viewing-while-recording options.

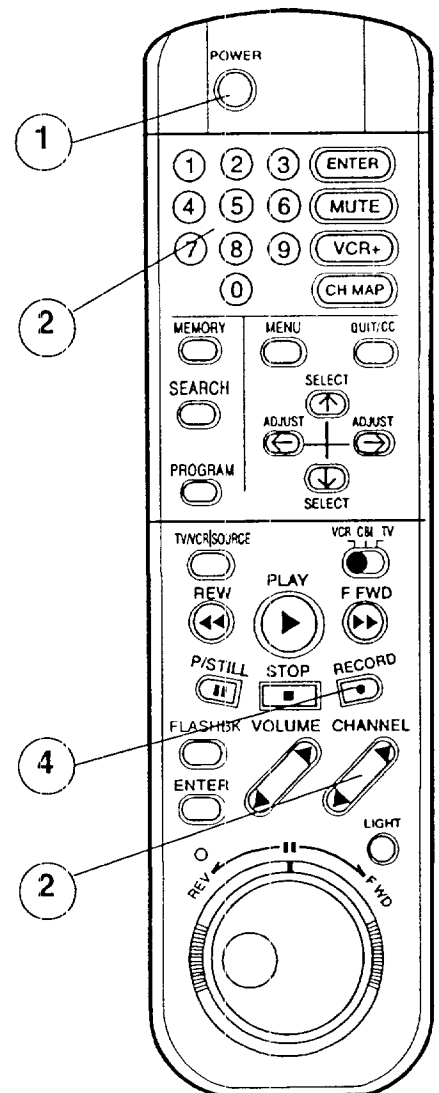

TIMER RECORDING WITH A CABLE BOX

Timer Recording Cable Programming (VCR turned off)

1. TV on, VCR on, tune VCR to cable/converter box output channel; 2, 3, 4, 5 or 6.
2. Cable/converter box on, tune to channel you wish to record and leave on.
3. Insert a VHS cassette tape.
4. Press **MENU**, select **TIMER**, enter information for programs 1, 2, etc. (Use Select, Adjust and numbered keys.)
5. Press **QUIT** when finished. Press **POWER** to turn VCR off and set VCR into Timer Recording mode. (See Timer Recording.)

Selecting Programs to Record

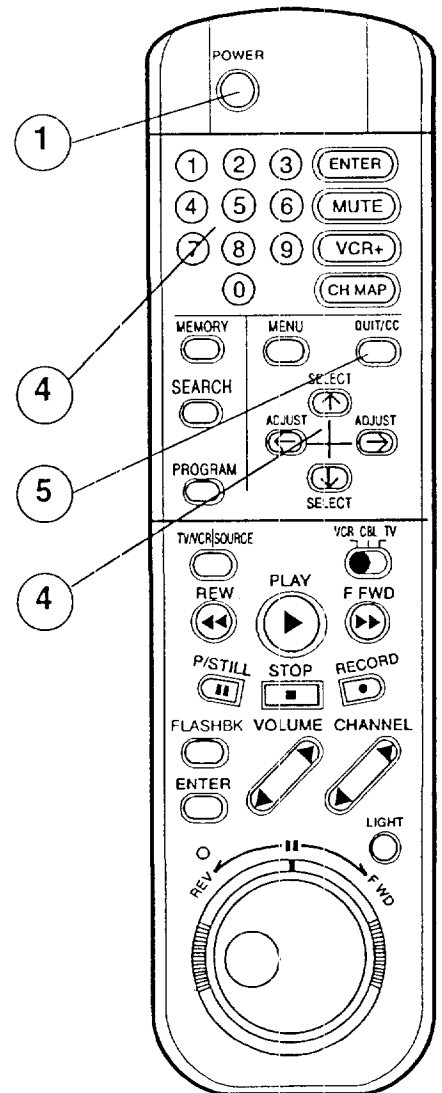
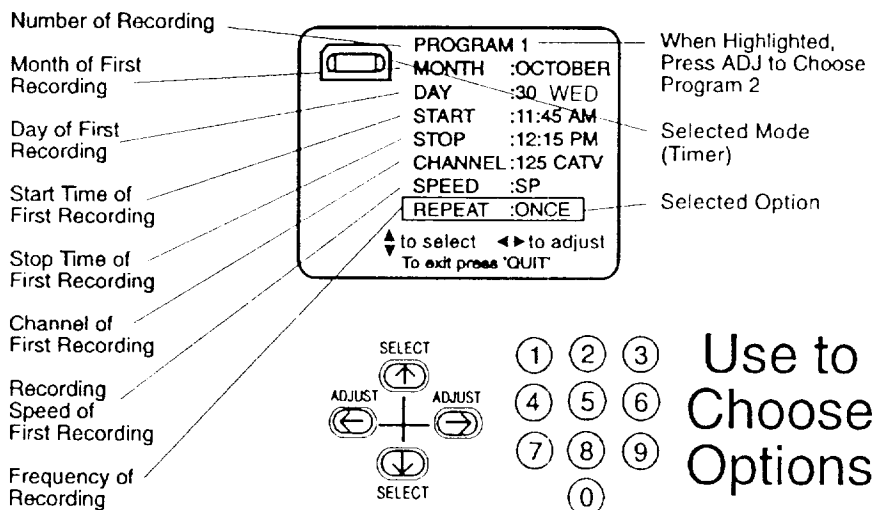

Note: While VCR is operating in **Timer** mode it cannot be operated manually. If needed, press **POWER** to release VCR from **Timer** mode.

Recording/Viewing Options

You can only watch what you are recording. Contact your cable company for their viewing one channel, while recording a different channel options.

Timer Recording Options

Once— will record a broadcast one time.

Weekly— will record a broadcast one time each week.

Daily— will record a broadcast, one time each day, Monday through Friday.

Capability— Timer can be programmed to record eight different events.

VCR PLUS RECORDING

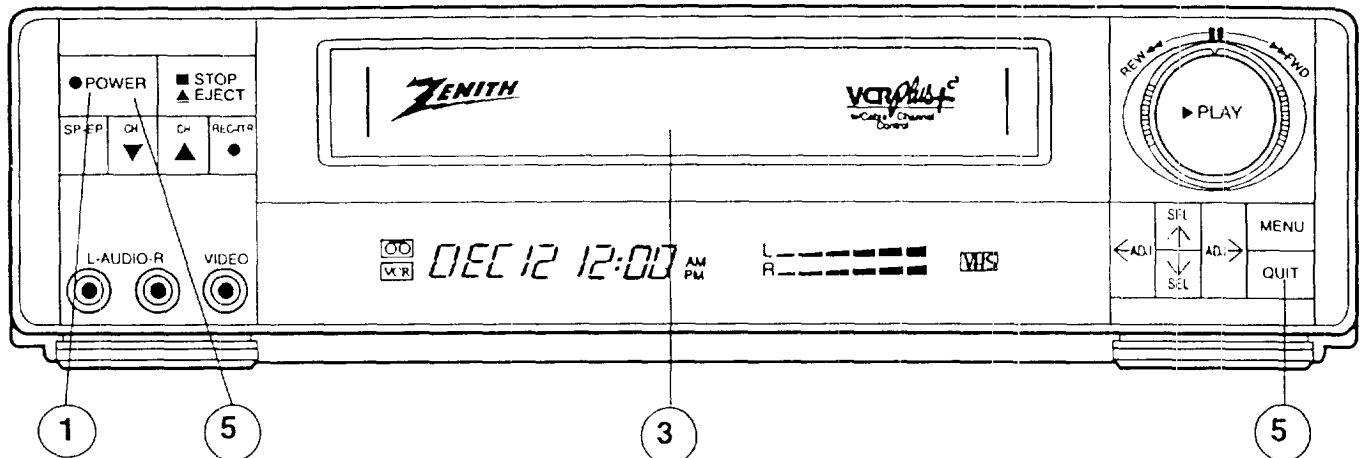

Recording VCR Plus Coded Programs (VCR turned off)

1. TV and VCR on.
2. Set Remote to VCR mode.
3. Insert a VHS cassette tape.
4. Press **VCR+**, follow on-screen instructions.
Key-in VCR PlusCode from local TV program guide, etc.
5. Press **QUIT** when finished. Press **POWER** to turn VCR off until recording time.

Notes: The **VCR Plus Recording Setup** in the next section must be completed before you can record using the **VCR Plus** feature.

While VCR is operating in Timer Recording mode it cannot be operated manually. If needed, press **POWER** to release VCR from Timer Recording mode.

Timer Recording Options

Once— will record a broadcast one time.

Weekly— will record a broadcast one time each week.

Daily— will record a broadcast, one time each day, Monday through Friday.

Capability — Timer can be programmed to record eight different events.

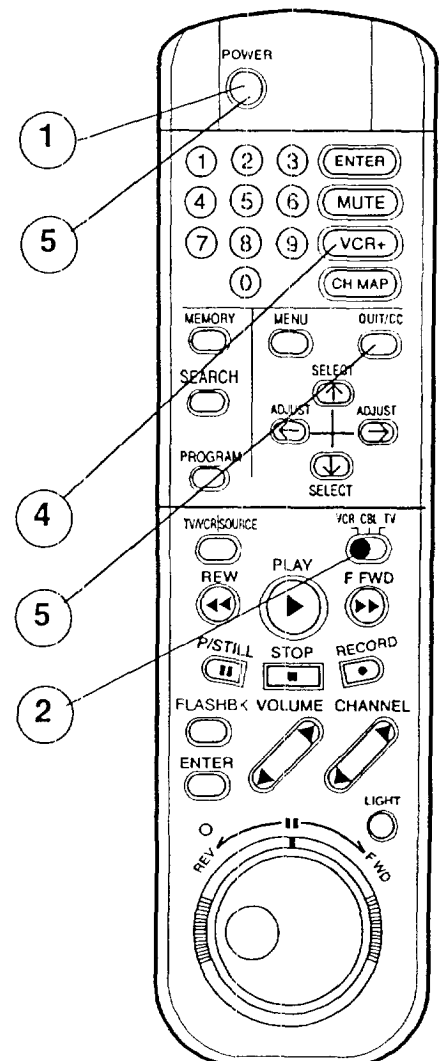

To find out which publications in your area carry the PlusCode— numbers, please call 1-800-2584-827.

VCR Plus+ and PlusCode are trademarks of Gemstar Development Corp. VCR Plus+ system is manufactured under license from Gemstar Development Corp.

VCR Plus+ et PlusCode sont des marques de Gemstar Development Corp. Le système VCR Plus+ est fabriqué sous licence de Gemstar Development Corporation.

VCR PLUS RECORDING WITH A CABLE BOX

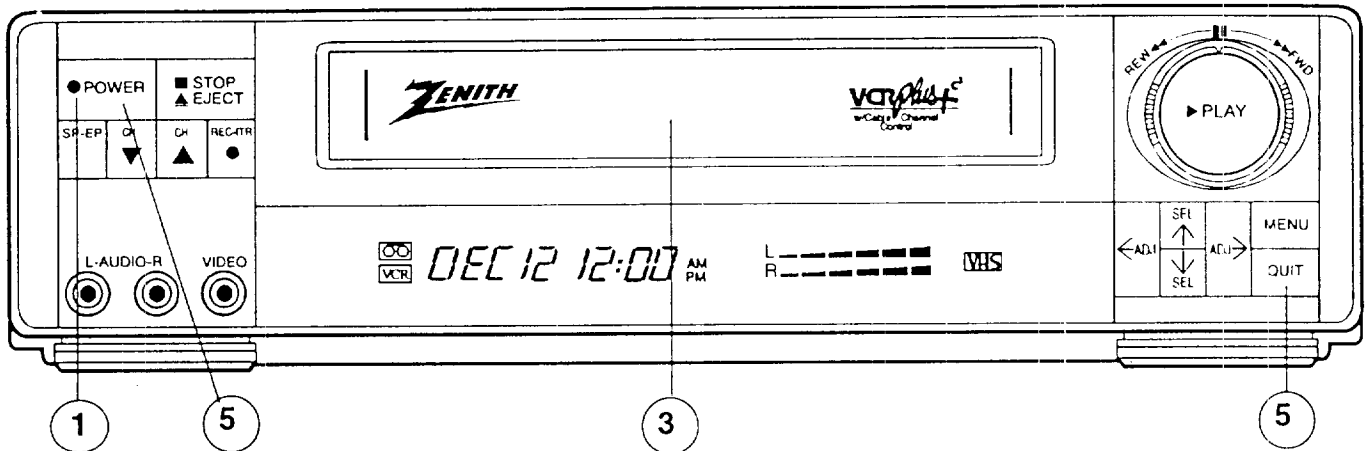

Recording VCR Plus Coded Programs (VCR turned off)

1. TV, VCR and cable box on.
2. Set Remote to VCR mode.
3. Insert a VHS cassette tape.
4. Press **VCR+**, follow on-screen instructions.
Key-in PlusCode from local TV program guide, etc.
5. Press **QUIT** when finished. Press **POWER** to turn VCR off until recording time.

Notes: The **VCR Plus Recording Setup** in the next section must be completed before you can record using the **VCR Plus** feature.

While VCR is operating in Timer Recording mode it cannot be operated manually. If needed, press **POWER** to release VCR from Timer Recording mode.

Timer Recording Options

Once— will record a broadcast one time.

Weekly— will record a broadcast one time each week.

Daily— will record a broadcast, one time each day, Monday through Friday.

Capability — Timer can be programmed to record eight different events.

To find out which publications in your area carry the PlusCode— numbers, please call 1-800-2584-827.

VCR Plus+ and PlusCode are trademarks of Gemstar Development Corp. VCR Plus+ system is manufactured under license from Gemstar Development Corp.

VCR Plus+ et PlusCode sont des marques de Gemstar Development Corp. Le système VCR Plus+ est fabriqué sous licence de Gemstar Development Corporation.

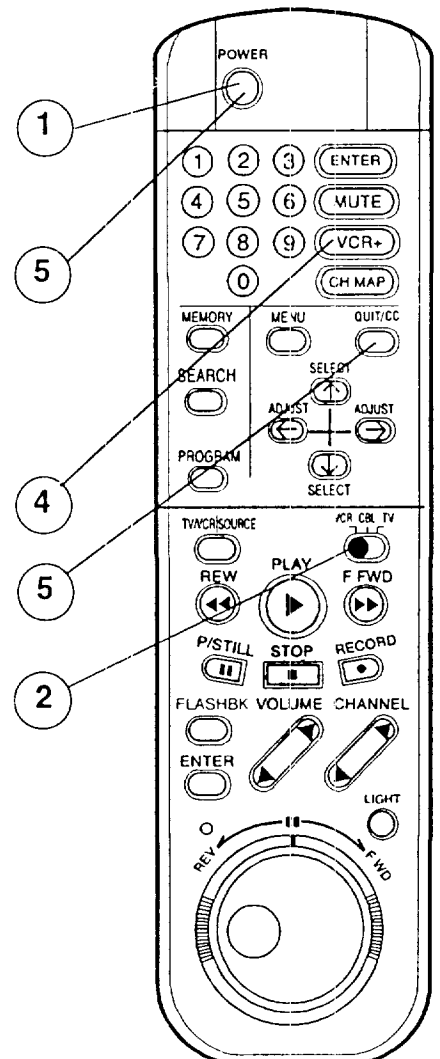

VCR PLUS RECORDING SETUP/Step C

Preliminary Setup, Outside Antenna

- Do Auto Channel Search procedure.
- Clock must be set to correct time.
- Source Select must be set to **Tuner**.
- Tuning Band must be set to **TV**.
- VCR, and TV must be turned On.
- TV/VCR SOURCE set to VCR (VCR appears in Message Center.)
- TV on and tuned to Channel 3 or TV Audio-Video In as the source of the TV picture, as appropriate.

1. Complete Channel Mapping Worksheet.

See page 12-4

2. Press **CH MAP** to begin VCR Plus Setup, follow on-screen instructions.

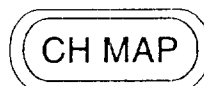

Preliminary Setup, Cable Service without a Cable Box

- Do Auto Channel Search procedure.
- Clock must be set to correct time.
- Source Select must be set to **Tuner**.
- Tuning Band must be set to **CATV**.
- VCR, and TV must be turned On.
- TV/VCR SOURCE set to VCR (VCR appears in Message Center.)
- TV on and tuned to Channel 3, or TV Audio-Video In as the source of the TV picture, as appropriate.

1. Complete Channel Mapping Worksheet.

See page 12-4

2. Press **CH MAP** to begin VCR Plus Setup, follow on-screen instructions.

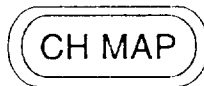

VCR PLUS RECORDING SETUP/Step C

Preliminary Setup, Cable Service with a Cable Box

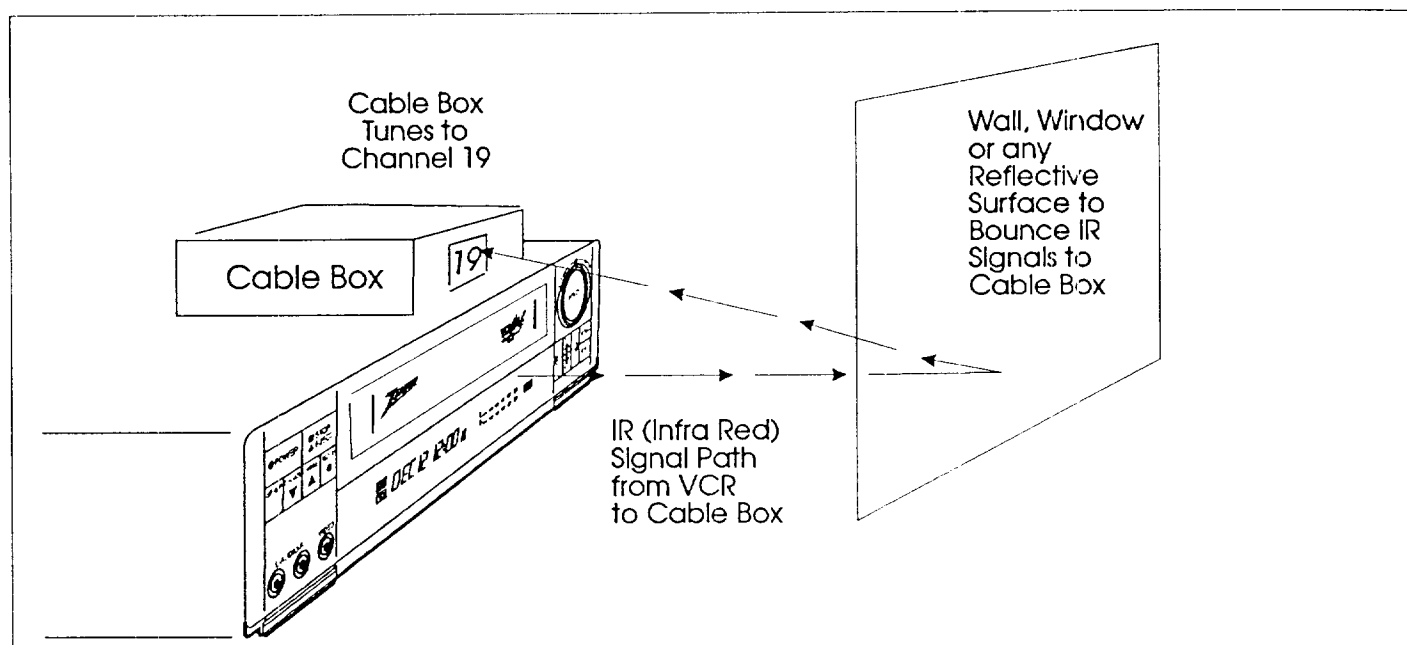

- Do Auto Channel Search procedure.
- Clock must be set to correct time.
- Source Select must be set to **Tuner**.
- Tuning Band must be set to **CATV**.
- VCR, cable box and TV must be turned On.
- TV/VCR SOURCE set to VCR (VCR appears in Message Center.)
- TV on and tuned to Channel 3, or TV Audio/Video In as the source of the TV picture, as appropriate.
- VCR tuned to cable box output channel number: 2, 3, 4, 5 or 6.
- Cable box must be connected to VCR ANT IN (IN FROM ANT).
- IR (Infra Red) Signal path from the VCR to the cable box must be unobstructed.

Write In:

Cable Box Output Channel Number

“MFR” Number(s)

1. For the Cable Box Test

Get the following information and enter in appropriate spaces below.

Cable Box Output Channel Number.

May be printed in cable box owner's manual or on cable box. If not, call cable company for number; 2, 3, 4, 5 or 6.

“MFR” Number.

A series of numbers for your particular cable box. If the first number does not work, try all the others in sequence. See page 12-3.

2. Complete VCR Plus Channel Mapping Worksheet.

See page 12-4

Press **CH MAP** to begin **VCR Plus Setup**, follow on-screen instructions.

If cable box test is successful, the cable box will tune to Channel 19 as shown above.

CH MAP

VCR PLUS RECORDING SETUP/Step C

MFR Numbers List

Archer	:1, 29, 42, 44, 76	Salora	:68, 72
Cabletenna	:29	Samsung	:4, 6, 32, 42, 78
Cableview	:42, 44, 63	Scientific Atlanta	:8, 9, 56, 61
Century	:44	Sheritech	:27
Citizen	:30, 42, 44, 52	Signal	:26
Curtis	:8, 9, 56, 61	Sprucer	:6, 16, 17
Diamond	:29, 44, 76	Stargate	:4, 6, 42, 44, 78
Drake	:37, 67, 71	Starquest	:6
Eagle	:13, 20, 21, 22, 23, 25, 58, 62	Sylvania	:19
Eastern	:28	Teknika	:54, 74
General Electric	:57	Telecaption	:77
General Instruments	:1, 2, 3, 4, 34, 55, 75, 83	Televue	:4, 6, 40, 42, 78
GC Electronics	:42, 44, 63	Texscan	:18, 19
Gemini	:4, 30	Tocom	:1, 33, 34, 42, 48, 49, 73
Gerrard	:44	Toshiba	:36, 66, 70
Hamlin	:14, 15, 28, 41	Uniden Satellite	:65, 69
Hitachi	:31, 79, 80	Unika	:29, 42, 44, 76
Jerrold	:1, 2, 3, 4, 34, 55, 75, 83	Universal	:42, 43, 44, 52, 63, 82
Jerrold Starcom	:1, 3, 4, 55	Videoway	:7, 45, 50, 59
Macom	:31, 79, 80	Vid Tech	:64
Maganavox	:13, 20, 21, 22, 23, 25, 26	Vidter	:64
Matsushita	:16	Viewstar	:13, 20, 21, 22, 23, 25, 40, 58, 62
Movietime	:32, 38, 39, 40, 60	Zenith	:7, 23, 45, 50, 59
NSC	:32, 38, 39, 40		
Oak/Oak Sigma	:10, 11, 12, 13, 46, 47		
Panasonic	:6, 16, 17		
Philips	:13, 20, 21, 23, 24		
Pioneer	:5, 6, 78		
Pulser	:42, 44		
Quest	:78		
RCA	:6, 16, 17		
Realistic	:44, 51, 53		
Recoton	:44		
Regal	:14, 23, 41		
Regency	:28		
Rembrandt	:29, 32, 42, 44, 60		
SL Marx	:4, 6, 42, 78		

All other cable/converter boxes use: 99

New MFR Numbers

The **MFR Numbers List** is a current listing of all available MFR numbers to date. If your cable/converter box does not tune to **Channel 19**, perhaps a newly created MFR number will work, that has not yet been published. In this case, try entering all MFR numbers starting with number **1** and continue through MFR number **83**, to see if the cable box will tune to **Channel 19**, and leave **Channel 19** remain selected.

Note:

If the system test is not successful, enter 99 as the MFR number. If the system test is not successful,

Channel Mapping Example

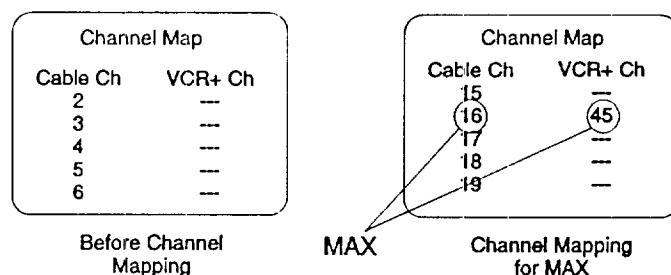

then the VCR cannot control the cable box functions. You will have to turn on the cable box and tune the channels manually for each recording. (Ch Review is not available with MFR No. 99.)

VCR Plus Channel Mapping Worksheet

Cable Company Assigned, and VCR Plus+ TV Channel Numbers for Your Local Broadcast Area

On the worksheet below, write in (with a pencil) each channel number that you receive these network's programming over. Write in the channel number. When Channel Mapping the VCR for your local broadcast area, you would enter the VCR Plus+ channel number on the same line that corresponds to the channel number you receive

these programs over. In the example shown on the previous page, a cable subscriber receives MAX on Channel 16. So, when channel mapping, the subscriber would enter 45 (for MAX) under the VCR Plus+ Ch column on the same line as Channel 16, as shown. Use your cable company's TV guide for reference.

In this column, write in the channel numbers you receive these networks on.	VCR Plus+ Channel Numbers
Over-the-Air Broadcast TV Channels VHF/UHF	
CBS	
NBC	
ABC	
PBS	
PBS	
Cable Network TV Channels CATV	
A & E	39
AMC	35
BRAV	54
CNBC	19
CNN	42
COM	21
C-SPAN (SATELITE)	
DIS	53
DISC	37
ENC	70
ESPN	34
FAM	47
HBO	33
LIFE	46

In this column, write in the channel numbers you receive these networks on.	VCR Plus+ Channel Numbers
Cable Network TV Channels CATV Continued	
MAX	45
MTV	48
NICK	38
SHOW	41
SC	59
TBS	43
TLC	51
TMC	58
TNN	49
TNT	52
USA	44
VH-1	62
WWOR	60

Note: Some of the VCR Plus+ numbers may vary in your particular broadcast area. Consult your TV guide; make any necessary additions or deletions.

ADDITIONAL INFORMATION

AUX Channel (Use to Play or Record from Accessory System Components)

(Connected to the VCR Audio/Video In Jacks)

Step 1. Press **MENU**. Press **ADJUST** Left/Right repeatedly to choose **SETUP**, press **MENU**.

Step 2. Use **SELECT** Up/Down to choose **SOURCE SELECT**.

Step 3. Use **ADJUST** Left/Right to specify **AUX**. This sets up the VCR to receive the signal from the system component (Video Disk Player, Hi-Fi Stereo, TV, Video Camera, Camcorder another VCR etc.,) connected to the **VCR AUDIO/VIDEO IN** (Rear or Front) connection jacks.

Note: When finished with the AUX channel, use the previously described method to choose **TUNER**.

AUX Channel Direct Access

Another method of choosing the AUX channel is to use **CHANNEL** Up/Down. The AUX Channel, is the lowest/highest number in the channel scan.

When you wish to return to normal VCR operation, simply use **CHANNEL** up/down to choose a different channel.

Index Search (Use to access each recorded segment's beginning)

Each time a recording starts, the VCR marks that location with an index mark; Index 1, Index 2, Index 3, etc. These locations can then be accessed by using the Search mode. (From the **Stop** or **Play** mode,) press **SEARCH** to begin Index Search mode.

For example, rewind the tape to the beginning.

Press **SEARCH**. To advance the tape to Index location three, follow on-screen instructions, then press 3. The tape will move to recording start Index location 3 and start playback. **Note:** This feature only works with tapes recorded on this VCR.

Real-Time Tape Counter

The Real-Time Tape Counter will only count recorded segments on VHS cassette tapes. If the on-screen tape counter stops at a location while the tape is moving, then the recorded segments have ended and blank segments are being passed over at that location on the tape; the Real-Time Tape

Counter will not count the blank (unrecorded) segments of a tape.

MEMORY— Press while a tape is being played or recorded, to zero the Real-time tape counter. If you activate the Counter Memory feature, the VCR will automatically stop at the **M 0:00:00** position when the tape is rewound.

Special Menu

—**AUTO CLOCK SET** On/Off Adjustment.

—**AUTO DAYLIGHT SAVINGS ADJUSTMENT** On/Off.

Step 1. Press **MENU** to place VCR Main Menu on TV screen.

Step 2. Press **4567** to access the Special Menu. Use **SELECT** and **ADJUST** keys to choose and specify:

Auto Clock Set/On— VCR will automatically set the clock.

Auto Daylight Savings Adjustment/On— VCR will automatically adjust the VCR clock for Daylight savings time.

Press **QUIT** when finished.

Note: Choose one option —Auto Clock Set and Auto Daylight Savings cannot be active at the same time.

Auto Tape Recording Speed Switching

While recording in **SP** (Standard Play) mode, if the VCR detects a shortage of tape necessary to complete the recording in **SP** mode it will automatically

switch to **EP** (Extended Play) mode to complete the recording assignment.

ADDITIONAL INFORMATION

Audio Record Mode

Step 1. Press **MENU**. Press **ADJUST** Left/Right repeatedly to choose **AUDIO**, press **MENU**.

Step 2. Use **SELECT** Up/Down to specify **AUDIO RECORD MODE**.

Step 3. Use **ADJUST** Left/Right arrows to specify:—**STEREO**, **MONO** or **2ND AUDIO**.

Stereo— Records sound from the left and right sound tracks as supplied by the program source.
Mono (Monaural)— Records Monaural sound only.
2nd Audio— Records the 2nd Audio sound track, if available.

Audio Playback Mode

Step 1. Press **MENU**. Press **ADJUST** Left/Right repeatedly to choose **AUDIO**, press **MENU**.

Step 2. Use **SELECT** Up/Down to specify **AUDIO PLAYBACK MODE**.

Step 3. Use **ADJUST** Left/Right arrows to specify:—**Hi-Fi**, or **Normal**.

Hi-Fi— Sound will be heard in Stereo, if available.

Normal— Sound will be heard in Monaural, whether Audio source is Stereo, Monaural or 2nd Audio.

Notes: Broadcast programs can be heard in Stereo as supplied by the broadcast signal to the TV Tuner. However, to hear Stereo sound from the VCR Tuner or during tape playback, you must use the VCR **AUDIO/VIDEO** Out jacks as the source. The TV, or sound source, must be set up to use (as the picture and sound source) the TV **Audio/Video** In jacks. Only the VCR **Audio/Video** Out jacks provide Stereo output for a tape playing in the VCR.

VCR Plus Recording Setup Double Channel Mapping

In a few parts of the country, some VCR Plus+ users will need to channel map two VCR Plus+ Channel numbers to one TV Channel Number. If two VCR Plus+ Channel numbers are printed in your TV Guide for one TV Channel number, you must channel map these two numbers in order for the VCR PlusCode to be interpreted by the VCR. Write these two numbers on the Channel Mapping Worksheet.

When Channel mapping, press **0000** to show the double channel mapping screen on the TV, continue Channel Mapping.

For further information on this special condition, call the Gemstar company at 1-800-4321-VCR.

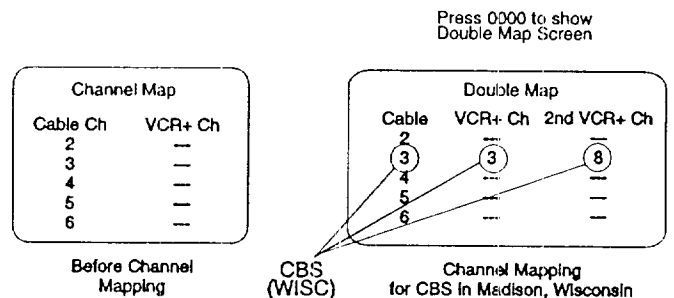

SERVICE INFORMATION

Before Calling for Service

Following are some common problems associated with operating a VCR. Please refer to the following Problem/Resolution Chart before calling for service. Many problems are created when the wrong key is pressed on the remote control. As a prelude to solving any VCR problem, turn TV, VCR and (if you have one) Cable Box on. Tune VCR to cable box output channel; 2, 3, 4, 5, 6, 7, 8 or 9. Tune Cable Box to desired channel. As necessary, select appropriate INPUT for the TV to receive the VCR signal, Channel 3 if you connected to the TV Antenna In. TV/VCR SOURCE set at VCR, so VCR appears in Message Center.—or TV Audio/Video Input, if you made Audio/Video connections to the TV. Tune TV to Audio/Video In as the source for the TV picture. For further information see System Operations Chart on the last page in this section.

Problem/Resolution Chart

Operating Problems		
Observed Condition	Possible Cause	Probable Solution
VCR does not respond to remote control keys or VCR buttons.	VCR software "lock-up" problem.	Disconnect power cord for 5 minutes, reprogram VCR if necessary.
No power to the VCR.	Power cord not connected.	Connect power cord.
Remote control does not function.	Batteries are weak.	Replace with new batteries.
No picture appears on TV screen.	Input on TV, not set to Audio/Video In, or TV not tuned to Channel 3. TV/VCR SOURCE set to TV.	Set INPUT source on TV to Audio/Video In, or tune TV to Channel 3, as appropriate. Set TV/VCR SOURCE to VCR, so VCR appears in Message Center.

Playing Tapes (Playback) Problems		
Tape will not fast forward or rewind.	Tape is fully rewound or fast forwarded.	No action required.
VCR operating sound is audible during operation.	Note: This is normal operating sound from internal mechanisms.	No action required.
Tape playing in VCR does not appear on TV screen.	TV input set to source other than VCR.	Set Input on TV to Audio/Video In or tune TV to Channel 3 as appropriate.
	TV/VCR SOURCE set to TV.	Set TV/VCR SOURCE to VCR, so VCR appears in Message Center.
Video "Noise" (horizontal streaks) appear during normal tape playing.	Tape is a rental or recorded on another VCR.	Use ADJUST Left/Right arrows to manually adjust tracking.
	Tape heads are dirty.	Clean Video heads.

Cable Service Problems		
No cable channel appears on TV screen.	Cable system not operating.	Call cable company for information.
	Cable box not turned on.	Turn on Cable Box.
	VCR not tuned to Cable Box output channel.	Tune VCR to Cable Box output channel. Call cable company for number.
	VCR SOURCE SELECT set to AUX.	Set VCR SOURCE SELECT to TUNER.

Recording Problems		
Observed Condition	Possible Cause	Probable Solution
Camcorder image is not shown on TV screen.	VCR SOURCE SELECT not set to AUX.	Set VCR SOURCE SELECT to AUX.
Camcorder is not recording.	Camcorder is off.	Turn camcorder on.

SERVICE INFORMATION

Timer recording is not possible.	Clock is not set to correct time.	Set clock to correct time.
	Timer has been programmed incorrectly.	Reprogram Timer.
	VCR is on.	Turn VCR off to activate Timer.
	TIMER SET does not appear after programming timer.	Reprogram Timer.

Tuning Problems		
Some channels are skipped over when scanning channels.	Those channels are preset to be skipped.	Restore channels to channel search sequence; select ADD next to channel number.
Channel cannot be switched.	VCR is in Timer Recording mode.	Press POWER to release VCR from Timer Recording mode.
Picture and sound are weak or missing.	Antenna or cables are loose.	Tighten connections or replace cable.

Audio-Stereo Record/Playback Problems		
Stereo is not present from VCR output.	TV is not Stereo. VCR not connected to TV Audio/Video Input jacks.	Connect VCR to TV Audio/Video In (or Hi-Fi Stereo Audio In jacks.)
	VCR Audio Record Mode was not set to Stereo. Tape recorded with 2nd Audio or Monaural specified as VCR Audio Record Mode.	Set to appropriate Audio Record mode.
	VCR Audio/Video Output jacks not connected to TV Audio/Video input jacks.	Connect VCR Audio/Video Out to TV Audio/Video In.

VCR Plus Problems		
VCR records program on different channel than channel specified.	Channel Map Procedure is incorrect or was not performed.	Channel Map for your local broadcast area.
Recorded wrong channel or no channel with Cable Box.	Cable Box not tuned to channel you wished to record.	Tune Cable Box to channel you wish to record.
	Cable Box not turned on.	Turn Cable Box on and leave on.
	VCR not tuned to Cable Box Output Channel; 2, 3, 4, 5, 6, 7, 8 or 9.	Tune VCR to Cable Box Output Channel number. Call cable company for number if necessary.
No program on cable system.	Cable system not operating.	Call cable company for information.

SERVICE INFORMATION

MAINTENANCE

Auto Head Cleaning/Video Head Cleaning

The VCR automatically cleans the heads as it is used. However after long periods of use, the video heads may become clogged with accumulated dirt, causing distortion. When this occurs, use do-it-yourself wet head cleaning cassettes available through your nearest Sears Retail Store or Service Center.

Caution: Do not use dry head cleaning systems. They may seriously damage both the video recorder and cassette. When visual signs appear (snow, streaking in picture and horizontal pulling of picture) indicating the need for video head cleaning, please see your nearest Sears Retail Store or Service Center.

Cabinet Cleaning

The outside surfaces of the VCR may be cleaned with a soft lint-free cloth as required. Use care not to scratch the VCR during cleaning.

SERVICE INFORMATION

System Operations— VCR, TV and Cable Box

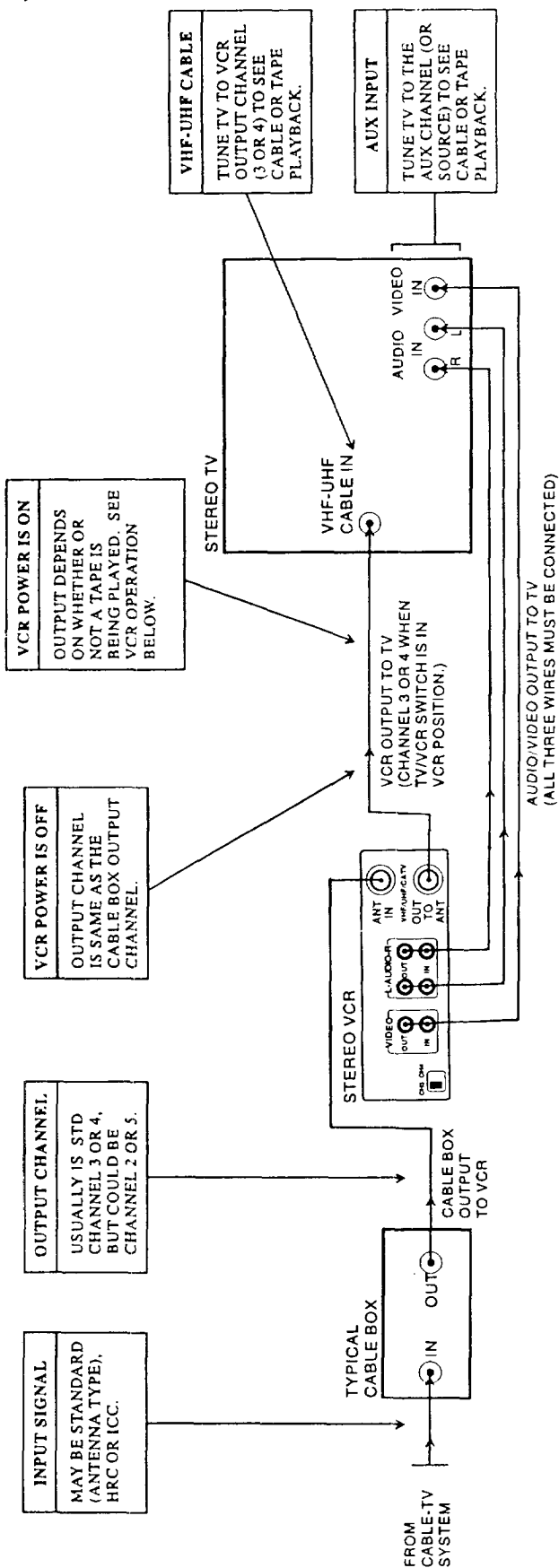

CABLE BOX OPERATION	
BOX IS OFF	EITHER NO OUTPUT IS PROVIDED OR A STANDBY CHANNEL IS PROVIDED.
BOX IS ON	CUSTOMER SELECTS DESIRED CHANNEL AT THE CABLE BOX. THIS IS THE ONLY CHANNEL WHICH CAN BE VIEWED OR RECORDED USING THIS BASIC SYSTEM SETUP.

VCR OPERATION WITH POWER ON	
PLAYING A TAPE	PLAYBACK IS PROVIDED AT ANTENNA OUT (CHANNEL 3 OR 4) AND AT A/V OUTPUT JACKS. STEREO AUDIO IS ONLY PROVIDED VIA THE A/V JACKS.
TV/VCR SWITCH IN TV POSITION	CABLE OUTPUT PASSES THROUGH VCR TO TV. TUNE TV TO CABLE OUTPUT CHANNEL. STEREO AUDIO IS PROVIDED IF PRESENT.
TV/VCR SWITCH IN VCR POSITION	CABLE OUTPUT IS PROCESSED IN VCR. TUNE VCR TO CABLE OUTPUT CHANNEL. PROGRAM IS PROVIDED TO TV AT ANTENNA OUTPUT AND A/V OUTPUT.
RECORD A TAPE	TUNE VCR TO CABLE OUTPUT CHANNEL WHEN TV/VCR SWITCH IS SET TO VCR. SEE INSTRUCTIONS FOR RECORDING A PROGRAM.

TV OPERATION	
TAPE PLAYBACK	USE THE AUX CHANNEL FOR BEST PICTURE QUALITY AND STEREO AUDIO DURING TAPE PLAYBACK. OR, SELECT CHANNEL 3 OR 4 TO SET TO VCR) SEE TAPE PLAYBACK BUT WITHOUT STEREO SOUND.
WATCHING A CABLE CHANNEL (VCR OFF)	TUNE TV TO CHANNEL 3 OR 4 AND TUNE CHANNELS USING CABLE BOX. (ALSO PROVIDED TO AUX CHANNEL WHEN VCR IS ON AND A/V CABLES ARE CONNECTED.)

VCR FEATURES CHART

FEATURES	VR4285HF
VCR Plus + + with Cable Box Control	X
4-Heads	X
MBR4285 Remote Control	X
On-Screen Audio Playback Menu	X
Front/Rear Audio/Video In Jacks	X
On-Screen Audio Record Mode Menu	X
Stereo Rear Audio In/Out Jacks Stereo Front Audio In jacks	X (Stereo VCR)
Rear Audio/Video Out Jacks	X
Record Speeds SP/EP	X
Playback Speeds SP/LP/EP	X
VCR Status On-Screen Display	X
Auto Clock Set	X
Auto Daylight Savings Adjustment	X
Auto/Manual Digital Tracking	X
Auto Head Cleaner	X
Auto Playback System	X
Auto/Manual Tuning Band Select	X
Auto/Manual Channel Search	X
Instant Record	X

FEATURES	VR4285HF
Timer Record	X
Jog/Shuttle Frame-by-Frame Forward/Reverse Slow Motion Viewing Control	X
VCR Message Center Display	X
Channel Add/Delete Feature	X
Forward/Reverse Speed Search	X
Forward/Reverse Jet Search	X
Forward PlayX2 Feature	X
Reverse PlayX3 Feature	X
Forward/Reverse Slow Motion	X
English/Spanish On-Screen Menus	X
Pause/Still Video	X
Hook-up Cable	X
Index Search	X
Jet Search	X
Speed Search	X
181 Channel Capability	X
1 Year, 8 Event Timer	X
10 Minute Power Backup	X
Real-Time Tape Counter	X
Real-Time Tape Counter Memory	X

Note: All features, Graphics, VCR Buttons/Remote Control Keys labeling and Software Menus are subject to change without prior notice.

X — Feature is provided



For the repair or replacement parts you need

Call 7 am - 7 pm, 7 days a week

1-800-366-PART

(1-800-366-7278)

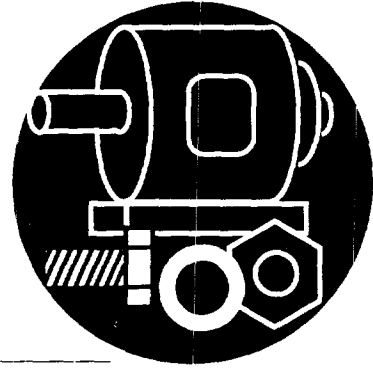

For in-home major brand repair service

Call 24 hours a day, 7 days a week

1-800-4-REPAIR

(1-800-473-7247)



**For the location of a
Sears Repair Service Center in your area**

Call 24 hours a day, 7 days a week

1-800-488-1222



**For information on purchasing a Sears
Maintenance Agreement or to inquire
about an existing Agreement**

call 9 am - 5 pm, Monday-Saturday

1-800-827-6655



SEARS
REPAIR SERVICES

America's Repair Specialists

**OWNERS
MANUAL**

MODEL NO.

VR4285HF

S-WARR

VHS

**VIDEO CASSETTE
RECORDER**

Your Sears Video Cassette Recorder has added value when you consider that Sears has service units nationwide staffed with Sears trained technicians... professional technicians specifically trained on Sears home entertainment products; having the parts, tools and equipment to insure that we meet our pledge to you... "We Service What We Sell."

Should a need ever exist for repair parts or service, simply contact any Sears Service Center/Department.

WARRANTY

This product is exclusive to and is warranted solely by Sears. For 90 days from the date of purchase, Sears will repair any defect in material or workmanship in this video cassette recorder, free of charge. For one year from the date of purchase, Sears will supply, at no charge, replacement for defective parts.

The above warranty coverage applies only to video cassette recorders which are used for private household purposes.

TO OBTAIN WARRANTY SERVICE, SIMPLY RETURN THE VIDEO CASSETTE RECORDER TO THE NEAREST SEARS SERVICE CENTER/DEPARTMENT IN THE UNITED STATES.

This warranty gives you specific legal rights, and you may also have other rights which vary from state to state.

Sears, Roebuck and Co.,
Dept. 817WA, Hoffman Estates, IL 60179

Sears, Roebuck and Co., Hoffman, IL 60179. U.S.A.