

CoverCell25K/100K700

Technician's Operational Manual
& Installation Guide











Ver. 1.0

GS Teletech Inc.

Contents of Box(A)

Contents	Picture	Quantity	Contents	Picture	Quantity
Repeater		1EA	Ground Cable 6.6ft (2m)		1EA
Mounting Bracket		1EA	Ground Sems Screw M4 x 8mm		4EA
Installation Guide CD		1EA	Bracket Sems Screw M6 x 16mm		4EA
Ethernet Cable 6.6ft (2m)		1EA	Lag Screw 1/2" x 2"		4EA
Power Cord 6.6ft (2m)		1EA	Anchor Bolt Set 1/2" x 2"		4EA
Registration Form		1EA			

Contents of Box(B)_Option

Contents	Picture	Quantity	Contents	Picture	Quantity
RF Cable 33ft(10m)		1EA	ANT Pole Set		1Set
RF Cable 66ft(20m)		1EA			
Donor ANT		1EA	Cable Clamp		12EA
Coverage ANT		1EA	(+)FH Tapping Screw for Clamp Ø4 x 25mm		24EA
Cable Tie		12EA	Universal Filter Kit		1EA
Wide Band 2way Splitter (300MHz - 2.5GHz)		1EA			

The images for the User Interface in this publication may vary from the repeater's depending on its S/W Version.

Copyright

© 2010, GS Teletech, Inc.
All Rights Reserved
Printed in Republic of Korea

Revision History

Date	Version	Changes
09/2010	1.0	Original

Certification

UL/FCC: This equipment complies with UL and FCC

Warnings and Hazards

WARNING! ELECTRIC SHOCK

Opening the BDA (bi-directional amplifier) could result in electric shock and may cause severe injury.

WARNING! EXPOSURE TO RF

Working with the repeater while in operation, may expose the technician to RF electromagnetic fields that exceed FCC rules for human exposure. Visit the FCC website at <http://www.fcc.gov/oet/rfsafety> to learn more about the effects of exposure to RF electromagnetic fields.

WARNING! DAMAGE TO EQUIPMENT

Operating the BDA with antennas in very close proximity facing each other could lead to severe damage to the repeater.

RF EXPOSURE & ANTENNA PLACEMENT

Actual separation distance is determined upon gain of antenna used.

Please maintain a minimum safe distance of at least 8 inch while operating near the donor and the server antennas.

Also, the donor antenna needs to be mounted outdoors on a permanent structure.

WARRANTY

Unauthorized opening or tampering the BDA will void all warranties.

One-year Warranty will start when the ownership of CoverCell25K/100K700 is transferring.

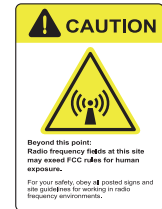

! **CAUTION:** REPEATER SHOULD BE INSTALLED AS CLOSE AS POSSIBLE TO POWER SOURCE.

! **CAUTION:** THIS REPEATER IS FOR INDOOR USE ONLY AND SHOULD BE LOCATED INSIDE OF BUILDING.

! **CAUTION:** RISK OF EXPLOSION IF BATTERY ON CONTROLLER BOARD IS REPLACED WITH AN INCORRECT TYPE.

! **CAUTION:** DISPOSE OF USED BATTERIES ACCORDING TO THE INSTRUCTIONS.

System Specification

ITEM		LTE	
		Downlink	Uplink
Frequency Range (MHz)		Upper C: 746 - 757	Upper C: 776 - 787
		Lower A: 728 - 734	Lower A: 698 - 704
		Lower B: 734 - 740	Lower B: 704 - 710
Bandwidth		Upper Band : 11MHz/Total	
		Lower Band : 6MHz/Band	
Gain/Adjust Range (Repeater)	25K	59dB - 79dB/30dB	
	100K	65dB - 85dB/30dB	
Output Power	25K	24dBm	
	100K	30dBm	
Waveform Quality (EVM) (Stability)		8% @CPL 15dB	12.5% @CPL 15dB
Noise Figure		7dB (Prefer 5dB) @ Maximum Gain	
System Delay		6us (Prefer 3us)	
VSWR		1.5 : 1	
Function		Automatic Gain Balance	
Out-of-Band Emissions		A,B,C : 43+10logP-100kHz/30kHz	A,B : 43+10logP-100kHz/30kHz C : 43+10logP
Single Tone Interference		≤ Input CW -40dBm (Operating band+/- 1MHz)	

Mounting Repeater

Masonry Wall

1. Using a pencil, mark the location of each of the mounting bracket's four mounting holes on the wall.
2. Drill holes in the wall at the locations marked in step 1.
3. Set the anchors in the wall using a hammer.
4. Locate the four mounting bolts and place a lock washer and flat washer on each bolt.
5. Place the mounting bracket over the four holes with anchors, making sure that the washers are on the repeater side of the mounting bracket. Tighten bolts until secure.

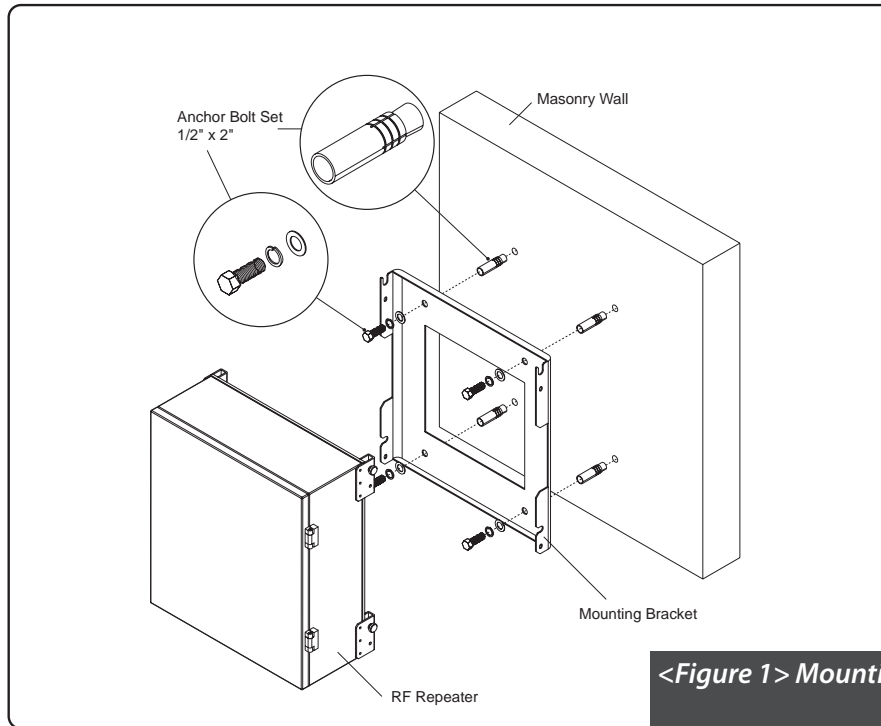

<Figure 1> Mounting the Repeater on a Masonry Wall

Mounting Repeater

Wood-Framed Wall

1. It is recommended to first attach a sheet of plywood to the wall. The sheet of plywood should be anchored to the studs in the wall.
2. Using a pencil, mark the location for each of the mounting bracket's four mounting holes on the plywood.
3. Place the mounting bracket over the four lag screws heads.
4. Thread a lag screw at the positions marked in step 2.

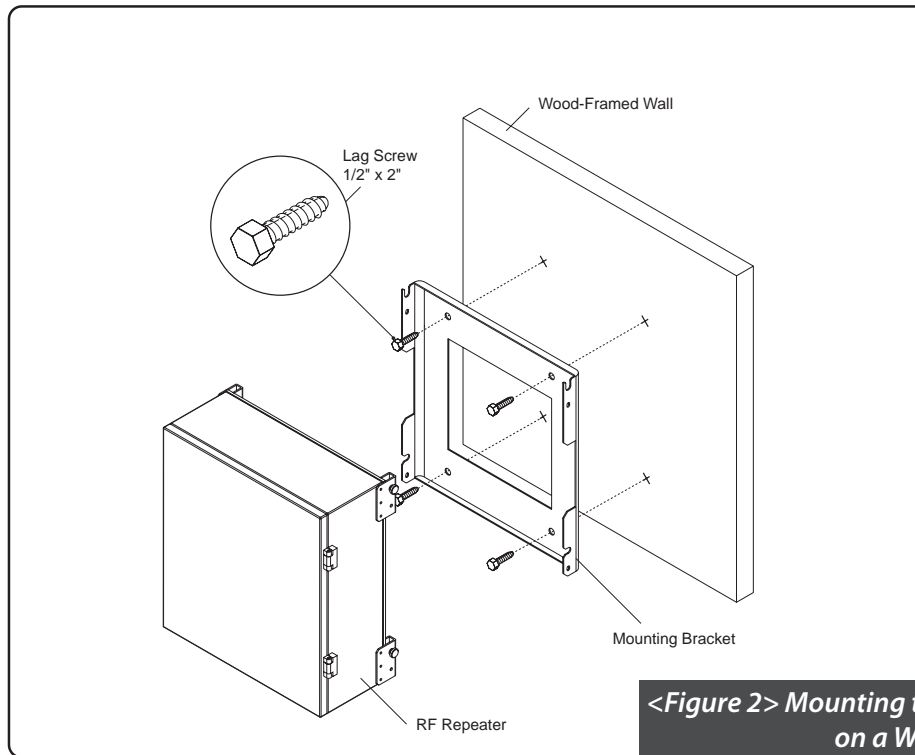

<Figure 2> Mounting the Repeater on a Wood-Framed Wall

Hanging and Grounding

1. Hang the Repeater from the mounting bracket.
2. Locate the four Bracket Sems Screws with installed washers. Tighten bolts until secure.
3. Locate the ground lug on the underside(or side) of the repeater.
4. Crimp the ground cable to the ground lug.
5. Route the free end of the ground cable to an approved(per local code or practice) ground source.



CAUTION

Ground cable must be properly grounded to provide both EMI and voltage surge protection for the repeater.

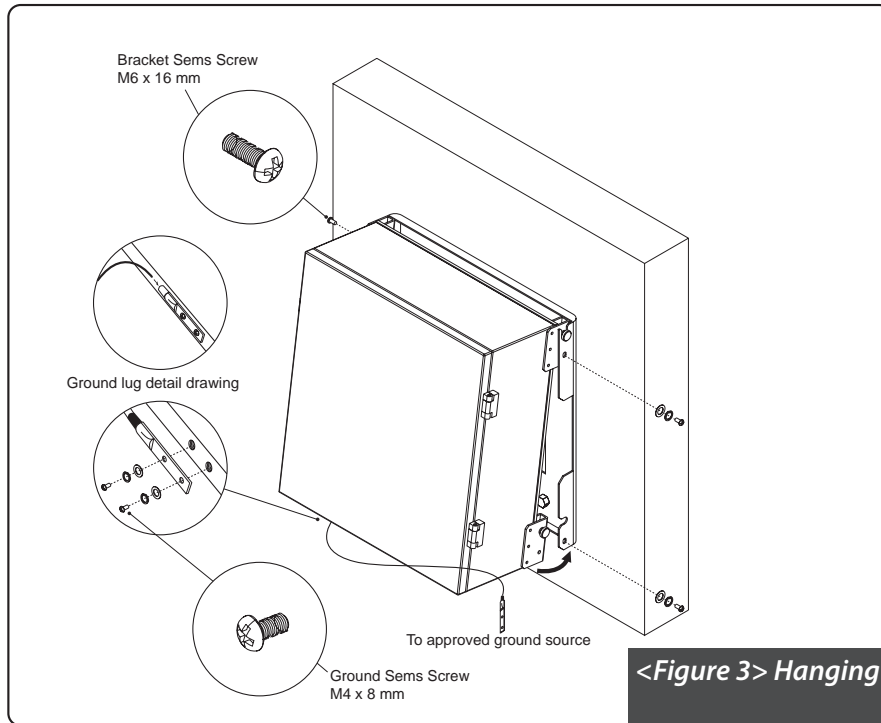

*<Figure 3> Hanging and Grounding
the Repeater*

Mounting Coverage & Donor ANT

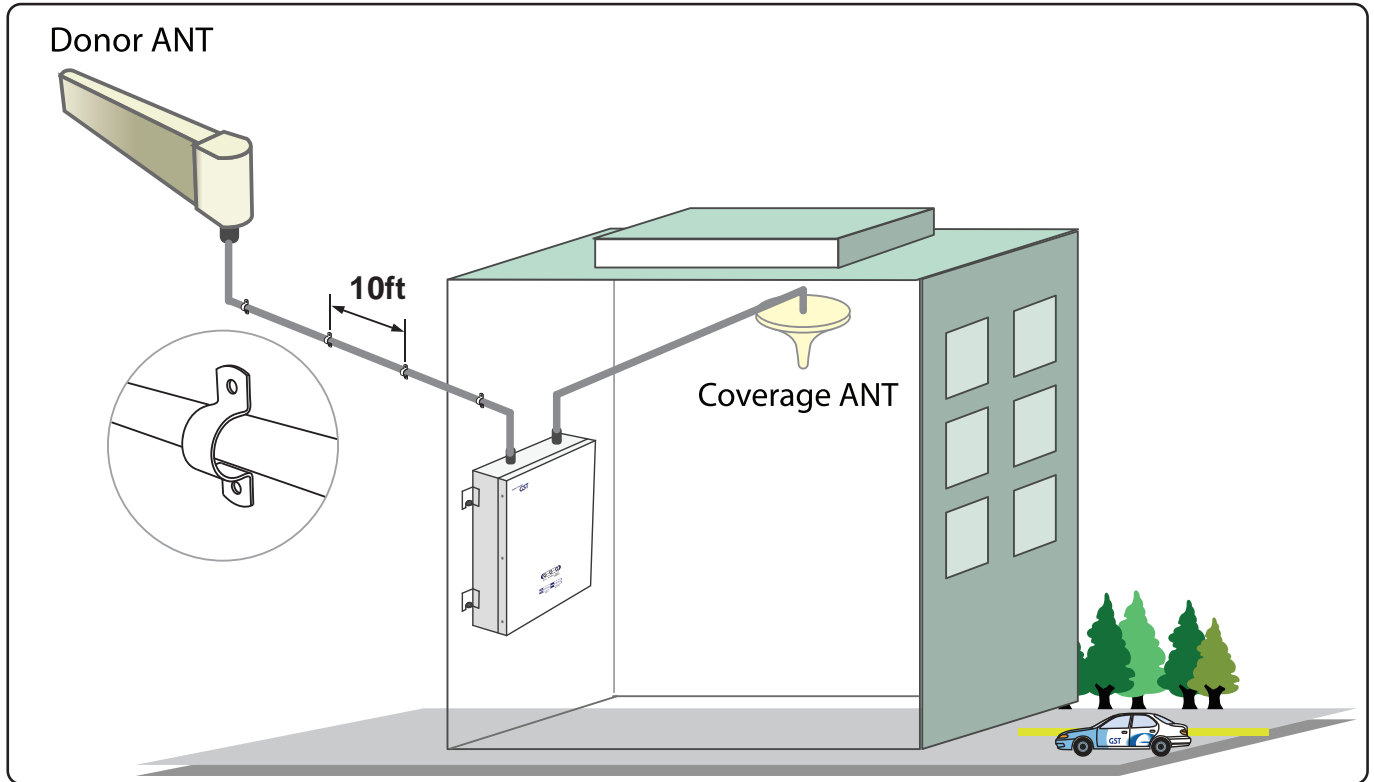

Coverage

- **Common Condition**

1. System Output Power -> LTE : 0dBm/FA @ pilot
2. Mobile Input Power : -90dBm/FA @ pilot
3. Donor Antenna Gain -> LTE : 8dBi
4. Coverage Antenna -> Common : 2dBi

- **SUBURBAN**

5. LTE : 1 channel -> 9dBm/total @ EIRP

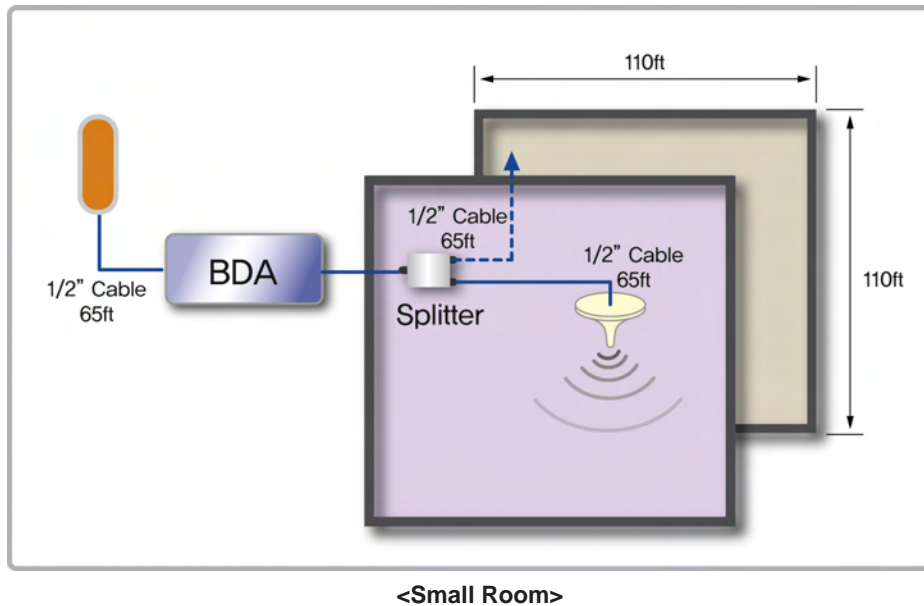

$$\text{Path Loss} = 32.44 + 20\text{Log}[\text{Frequency}] + 20\text{Log}[\text{Distance(km)}] + \text{Indoor Loss}$$

Coverage

- **Common Condition**

1. System Output Power -> LTE : 6dBm/FA @ pilot
2. Mobile Input Power : -90dBm/FA @ pilot
3. Donor Antenna Gain -> LTE : 8dBi
4. Coverage Antenna -> Common : 2dBi

- **SUBURBAN**

5. LTE : 1 channel -> 15dBm/total @ EIRP

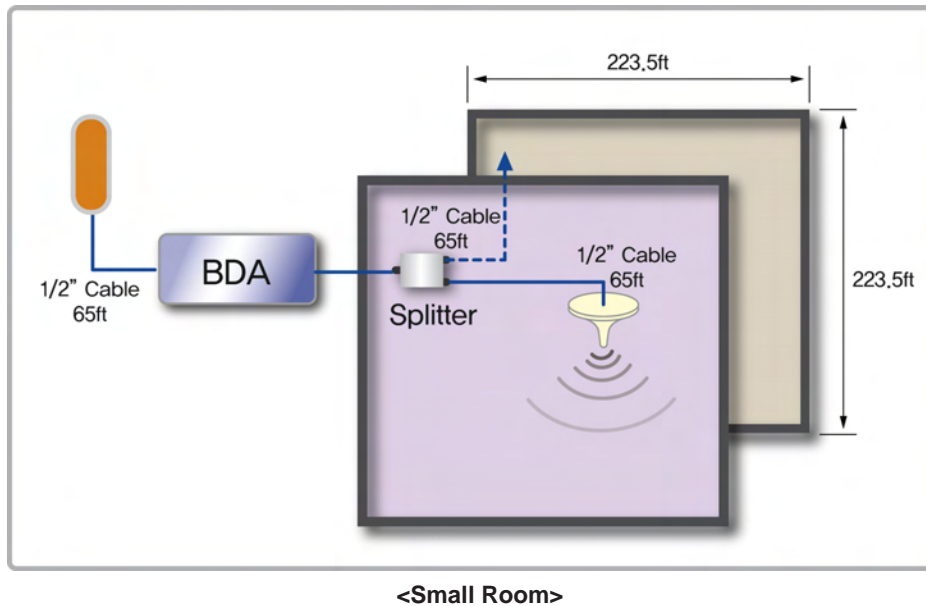

$$\text{Path Loss} = 32.44 + 20\text{Log}[\text{Frequency}] + 20\text{Log}[\text{Distance(km)}] + \text{Indoor Loss}$$

Mounting Donor & Coverage ANT

Mounting Donor ANT Pole

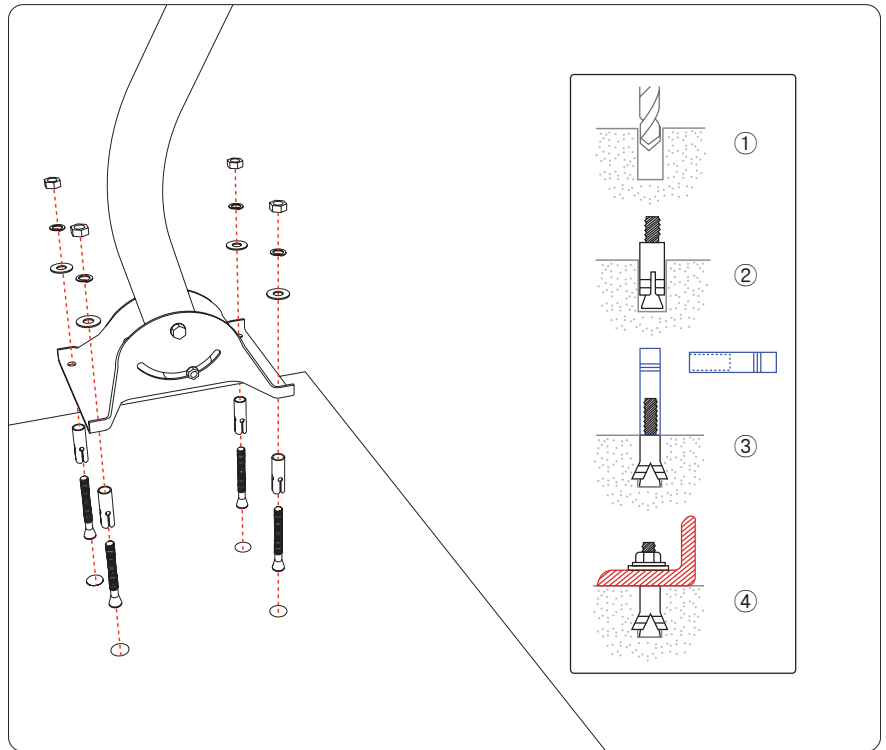
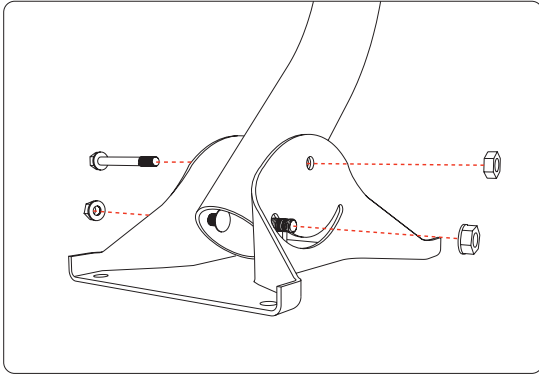

Mounting Donor & Coverage ANT

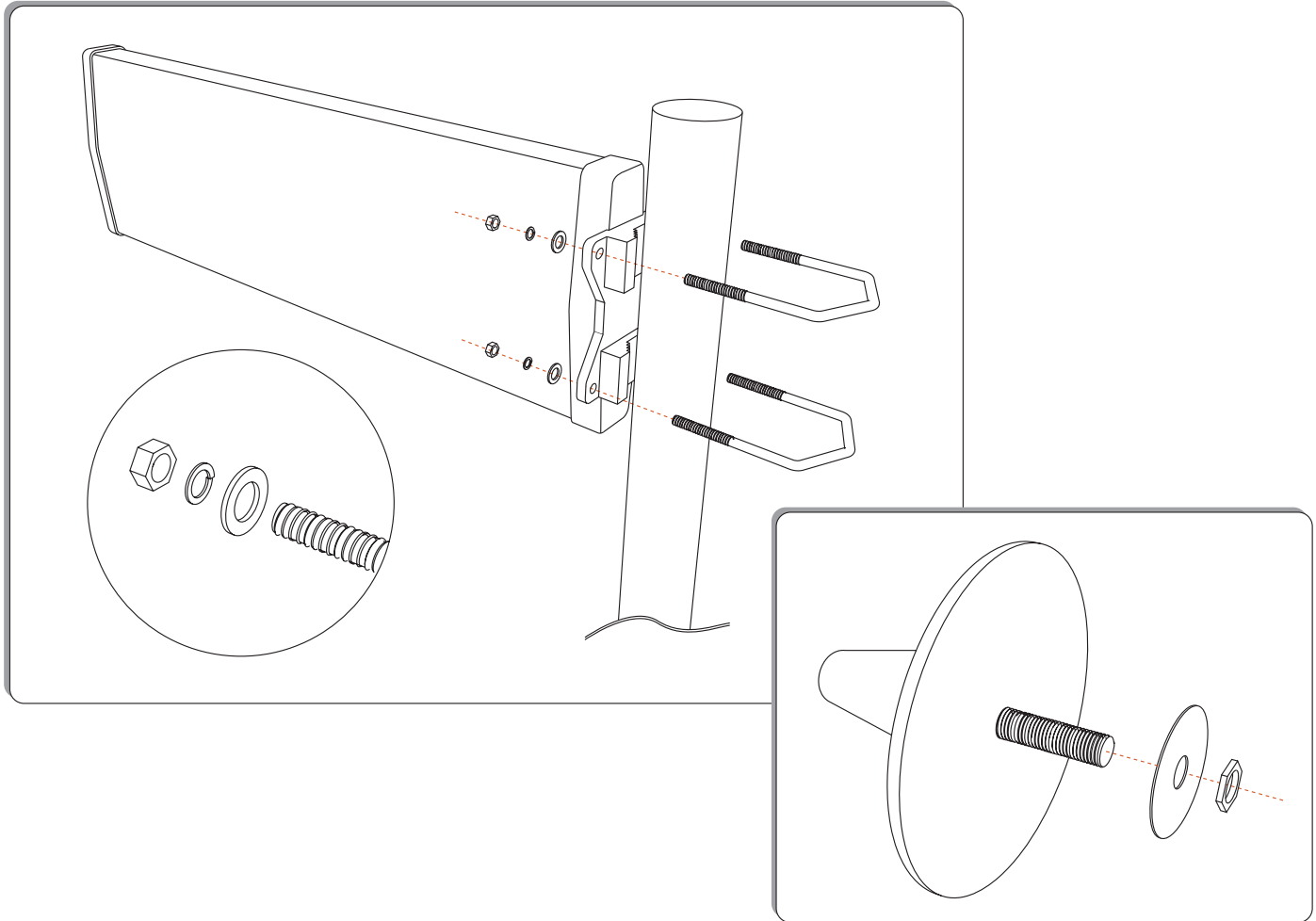

Mounting Type

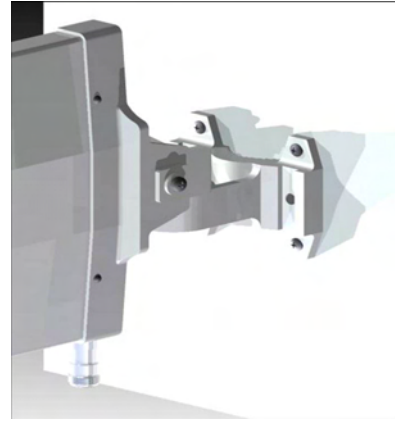
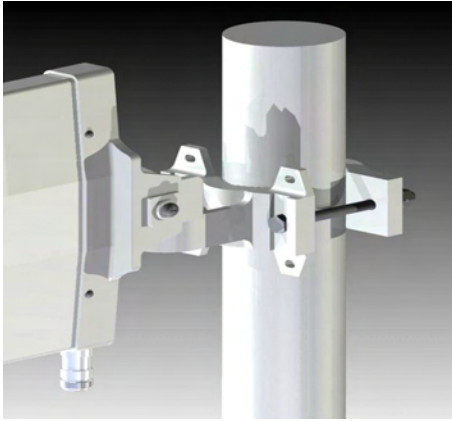

<Pole Mount>

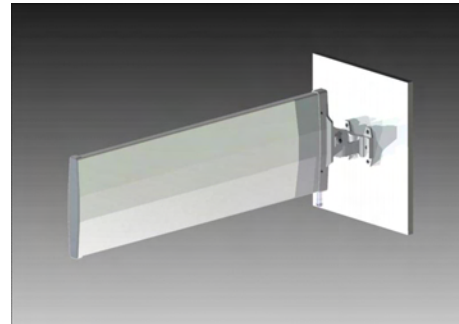

<Wall Mount>

Vertical Tilt

Vertical Beam Width	35 Deg
---------------------	--------

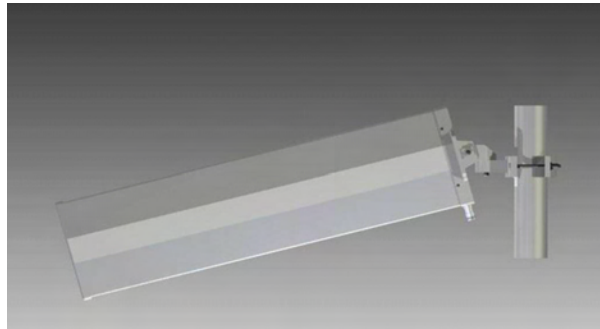
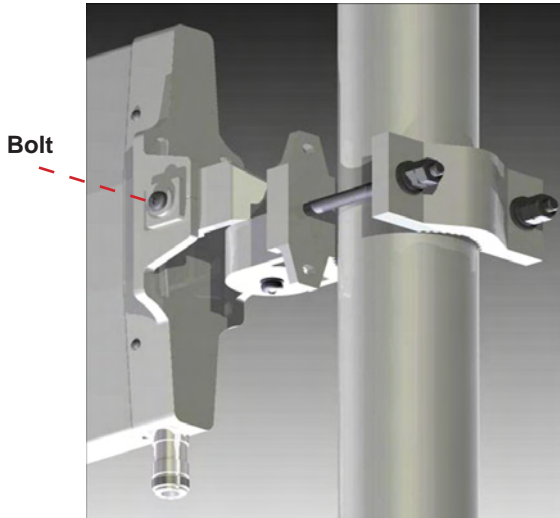

Horizontal Tilt

Horizontal Beam Width

90 Deg

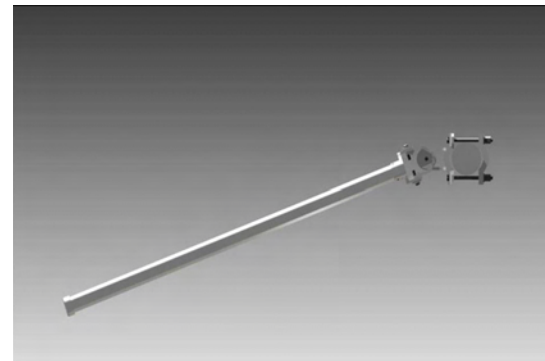
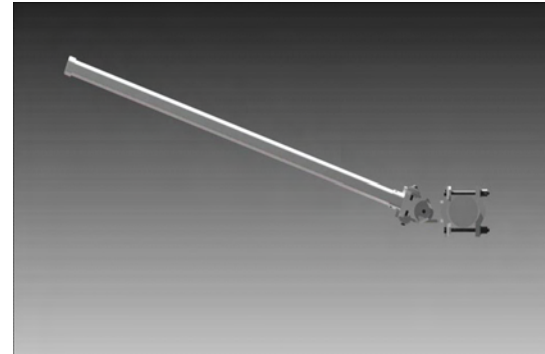
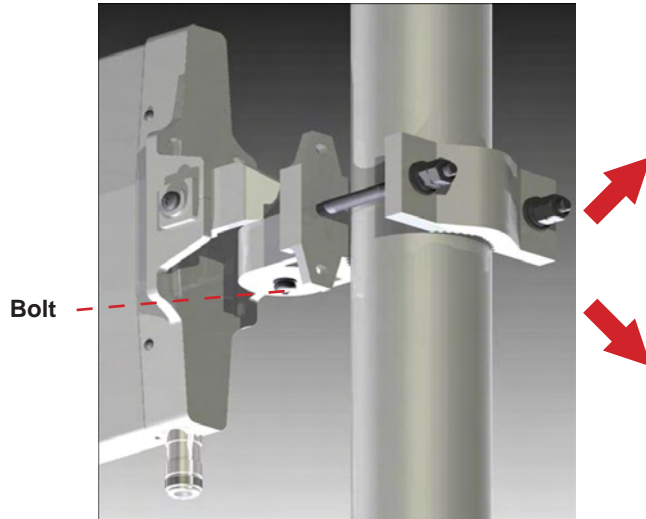

Mounting Coverage & Donor ANT

Item	Remark
Donor ANT	<ul style="list-style-type: none"> (1) Setting the direction of Donor Antenna (2) A donor antenna needs to be located in a place which maintains maximum receiving signal levels and attains highest Ec/Io values from BTS. (3) It is recommended that the antenna needs to be protected by placing it under the protection angle from a lightening rod. (4) A donor antenna needs to be away from high pressure and high frequency facilities. When installing a donor antenna, it needs open spaces at least more than 180 degree. (5) To get enough isolation between a donor antenna and a coverage antenna, those antennas needs to be away from each other.
Coverage ANT	<ul style="list-style-type: none"> (1) Choosing an efficient emitting place – It is recommended that the antenna should not be blocked by objects. (2) For signal quality, the cable length needs to be as short as possible. (3) The antenna needs to be away from other radio frequency radiating objects such as other antennas, and CCTV equipment.

Warning: In order to avoid the possibility of exceeding the FCC radio frequency exposure limits, human proximity to the antenna should not be less than 40cm during normal operation.

The gain of the antenna is 8 dBi.

Position Antenna

- Customer specifications should be followed for positioning the antennas properly.



<Figure 4> An installer is directing Donor Antenna to nearby BTS to receive strong input signal.

Cable Connections

- Connect Donor and Coverage Antenna



CAUTION

Do not connect or disconnect cable from ANT port when power is ON



<Figure 5> ANT Ports



<Figure 6> DONOR ANT Port Connection



<Figure 7> Covergare ANT Port Connection

Connecting Power Cable and LED Light Verification

- Connect Power Cable



<Figure 9> AC Power Port Connection



<Figure 10> Verification of LED Lights

- When turning on the repeater, AGS (Auto Gain Setup) is automatically activated, which shows LED indicators are turned on one by one.
- After all the LEDs are on, AGS is complete.
- Please verify that all the LEDs are indicating proper input and output levels.

AGS Algorithm description

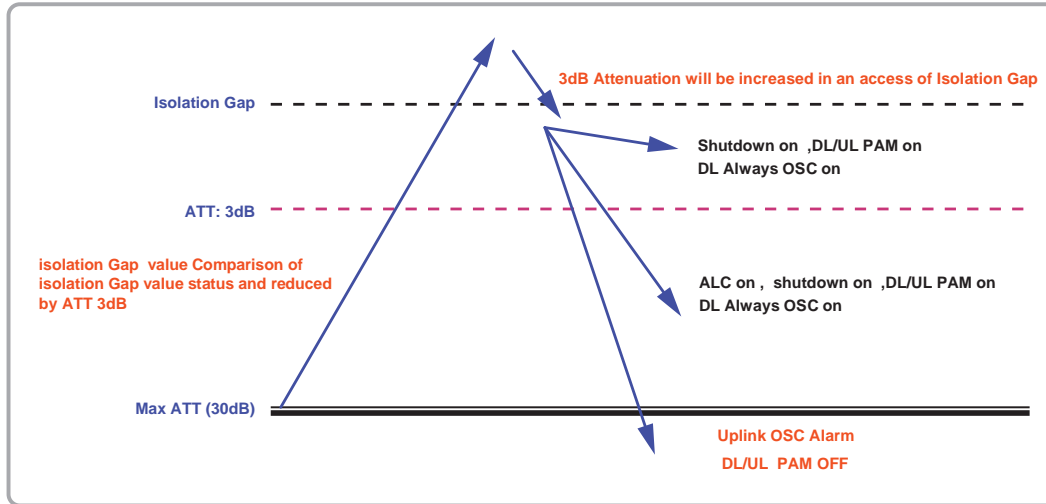

Oscillation can be reduced in case that 3dB Attenuation is increased in an excess of Isolation Gap
ATT status value : 0~2.5dB (Shutdown on , DL/UL PAM on, DL Always OSC on)
3dB~30dB (ALC on ,shutdown on , DL/UL PAM on, DL Always OSC on)
Over 30dB (uplink OSC Alarm , DL/UL PAM off)

References

1. Isolation Check in initial set up or Reset
2. Monitoring Oscillation comparing to minimum/maximum Noise Floor level
3. When Oscillation occurred, repeater attempts to stabilize Isolation through Gain control function
4. Shutdown repeater when Oscillation still occurs in Minimum Gain
5. Automatic Recovery Algorithm conversion after Shutdown status

LED Indicators

LED Status	Remark	Application Status
Tamper	Tamper	Enable
Built-in Fail	Built-in test fail	Enable
AGC	AGC Active	Enable
Rep Mod Fail	Replaceable module fail	Enable
Reset	Reset engaged	Enable
OSC	OSC detected	Enable
Shutdown	Shutdown	Enable
DL ANT Fail	Donor ANT circuit fail	Enable
DL Out Low	Donor Power too low	Enable
UL ANT Fail	Coverage ANT circuit fail	Enable

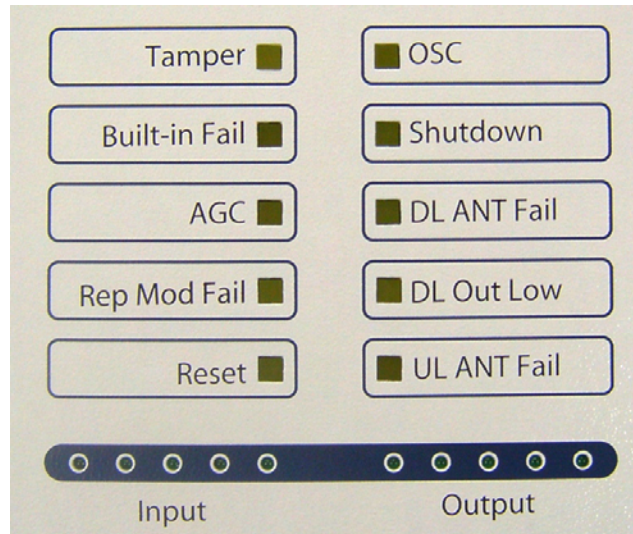

<Figure 11> Front LED Display

Input /Output Power Signal

- Please note the number of LED bars indicates the RSSI signal strength level at the Donor & Coverage ANT port.

The tables below indicate the levels.

< Input >

Less than -75dBm	LED 1bar
-74.5dBm ~ -70dBm	LED 2 bars
-69.5dBm ~ -65dBm	LED 3 bars
-64.5dBm ~ -60dBm	LED 4 bars
More than -59.5dBm	LED 5 bars

< Output >

Less than +4.5dBm	LED 1bar
+5dBm ~ +9.5dBm	LED 2 bars
+10dBm ~ +14.5dBm	LED 3 bars
+15dBm ~ +19.5dBm	LED 4 bars
More than +20dBm	LED 5 bars

Web UI

- Before connecting to repeater, disable wireless networking functions and remove wireless broadband card.
- Connect Ethernet Crossover cable from repeater LAN port to laptop.

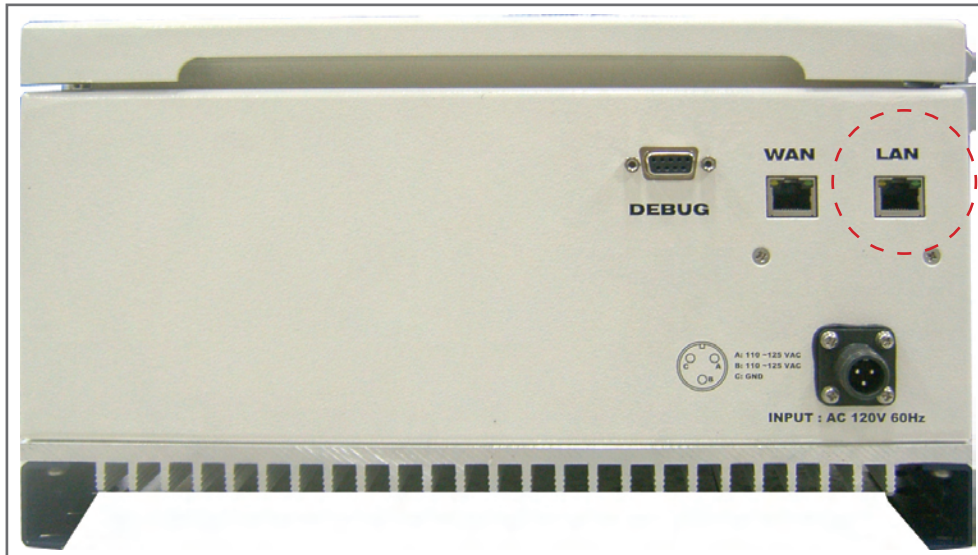

<Figure 12> WAN Port Display

Connecting to Web UI

1. Start-> Control Panel-> Network and Internet Connections



CAUTION

Disable wireless connections and remove wireless broadband card.

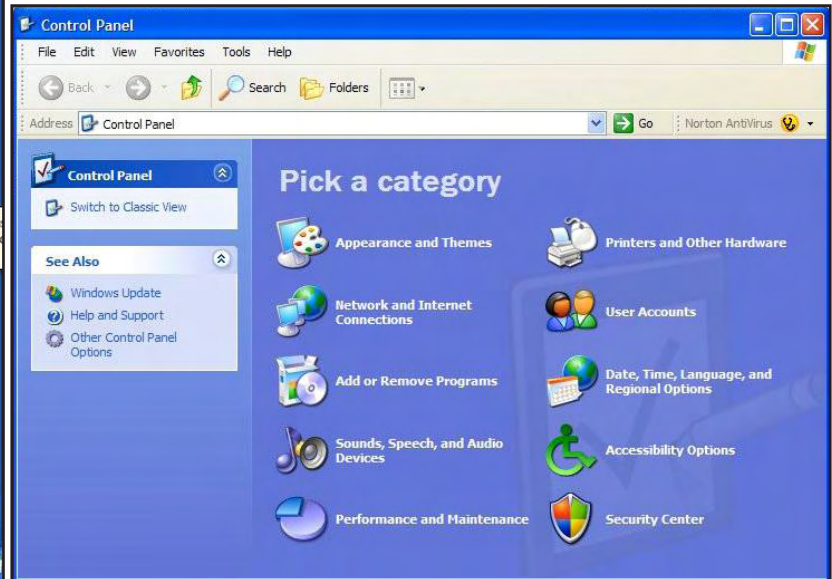

Connecting to Web UI

2. Right click Local Area Connections and choose Properties
 - If your laptop is displaying multiple LAN's, verify which one is used for repeater connection.
3. Click Internet Protocol (TCP/IP) on General Tab and click Properties

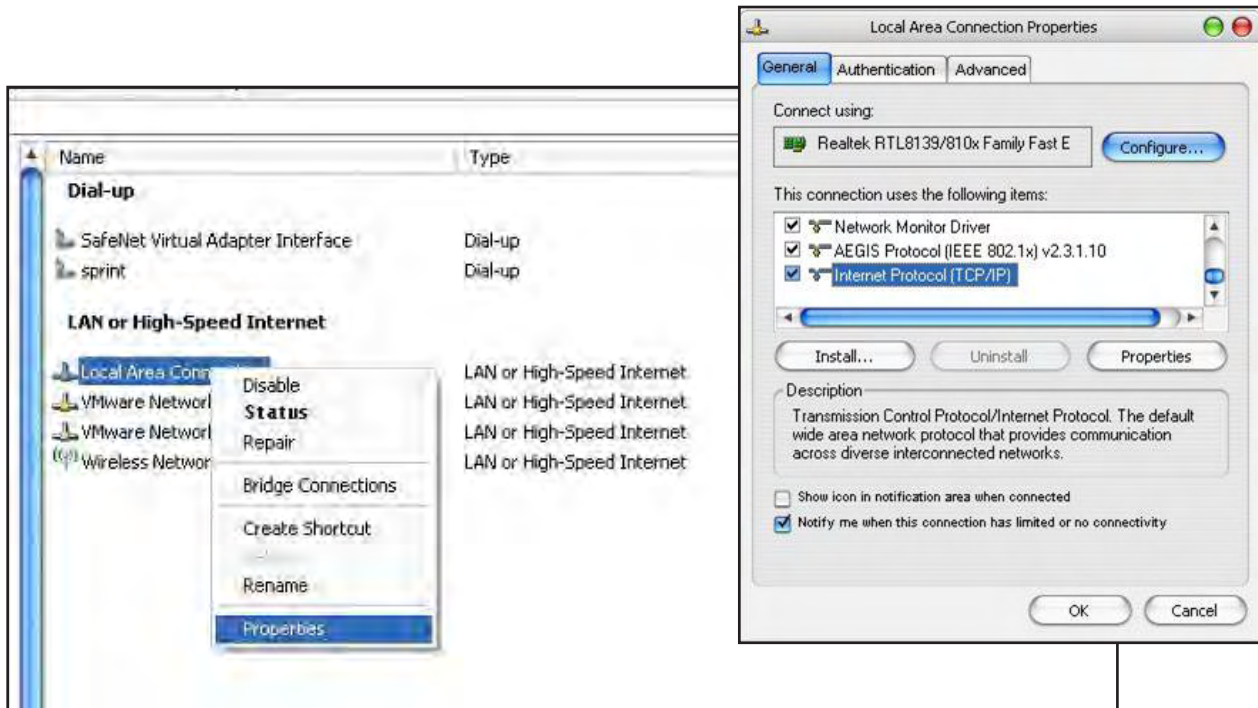

On General Tab

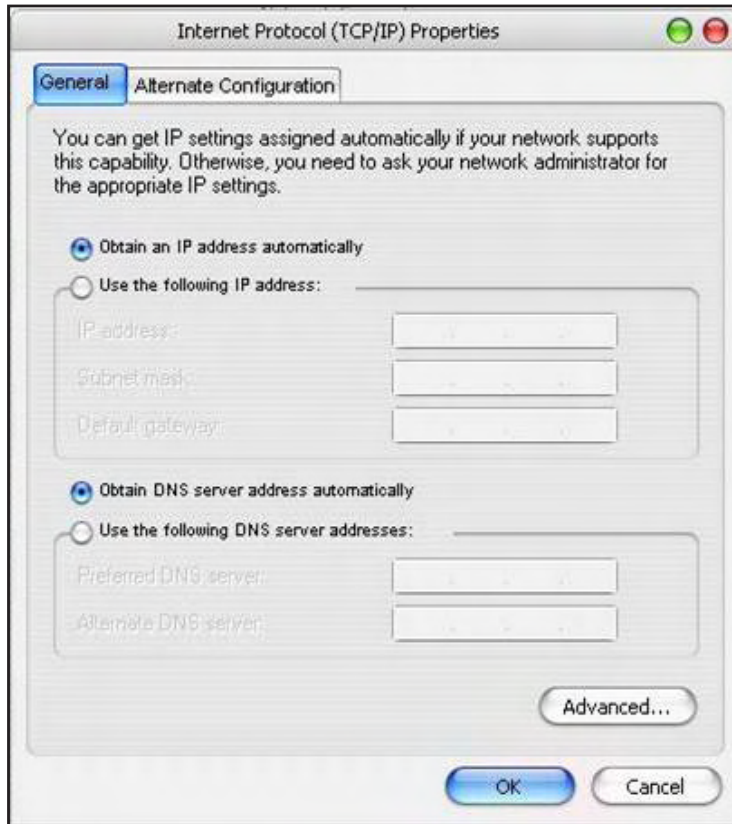

4. Choose "Obtain IP address automatically"

5. Choose "Obtain DNS server address automatically"

6. Click "OK" to close Properties

7. Click "OK" to close Properties

Connecting to Web UI

8. Right click Local Area Connections and choose Status

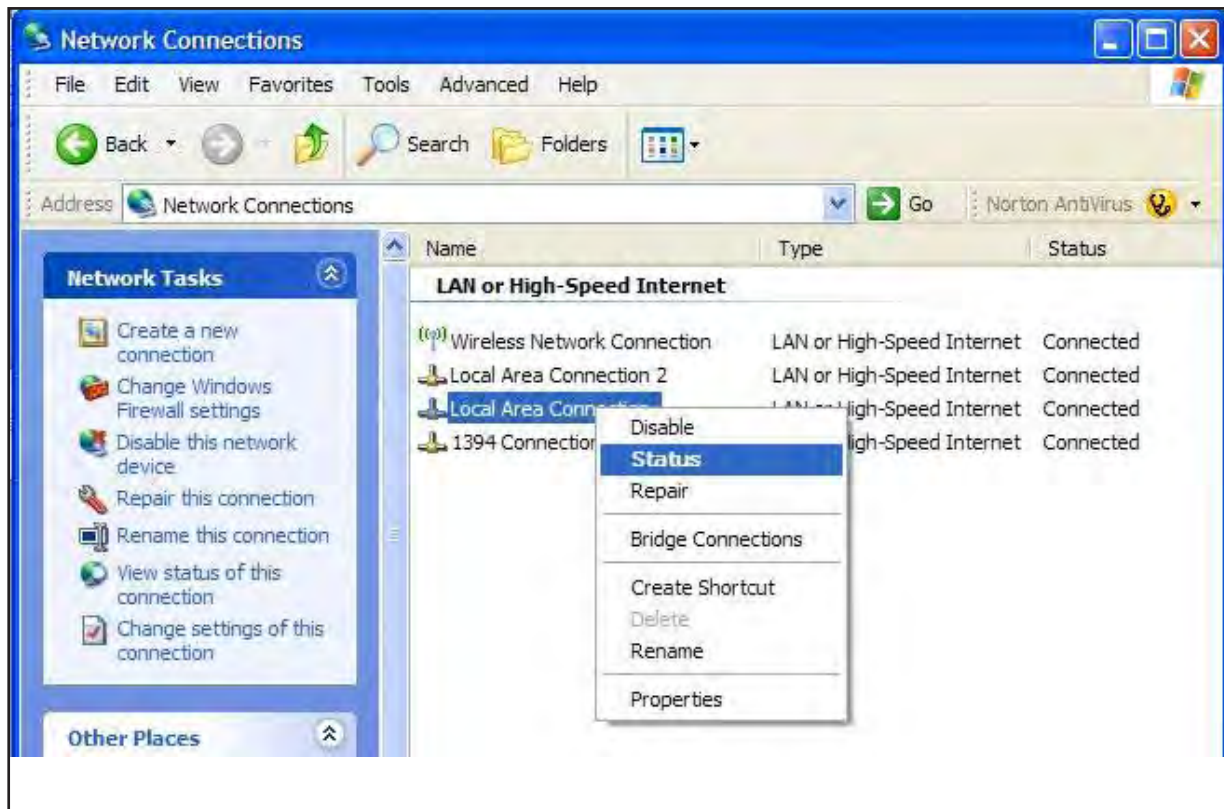

Verify Assigned IP Address

9. Click on "Support" tab.
10. Verify assigned Default Gateway at local connection. *(If IP address is not assigned, please click repair.)*
11. Close all windows when finished.

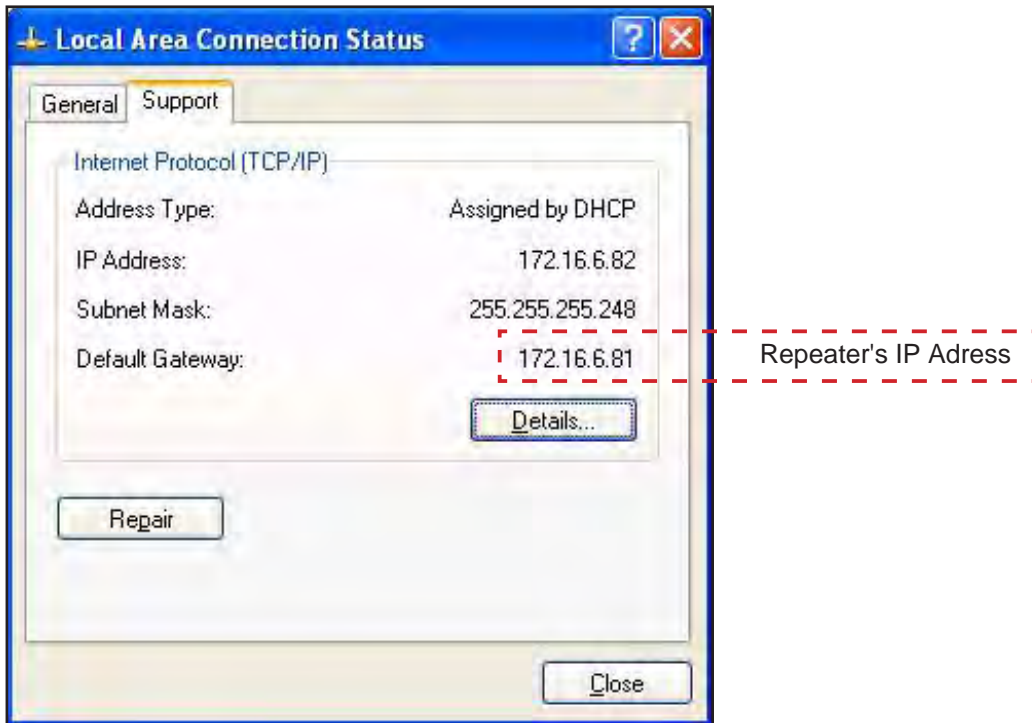

Internet Explorer Option Settings

- Proceed step by step as indicated in the following slides to delete all temporary internet files and records.

1. Open Internet Explorer -> Tools -> Internet Options

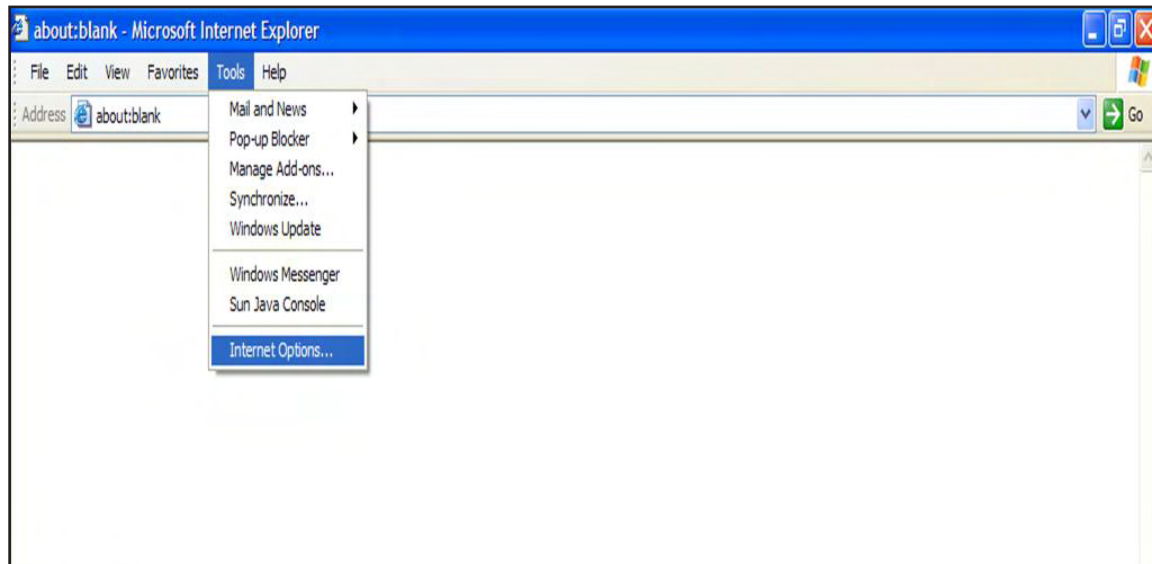

Browser History Options

On the “General” tab, in the “Temporary Internet files” section:

2. Click "Delete Cookies..."
3. Click "Delete Files..."
4. Click "Apply"
5. Click "OK"



Login Screen

172.16.6.81

Enter Default Gateway's IP address into address bar as previously described, you will be redirected to Login. Default User Name is 'admin', and default Password is 'admin'. You may need to change password as described in the User Management section.

List Menu

- After you log in, you can see various menu page links related to the equipment.

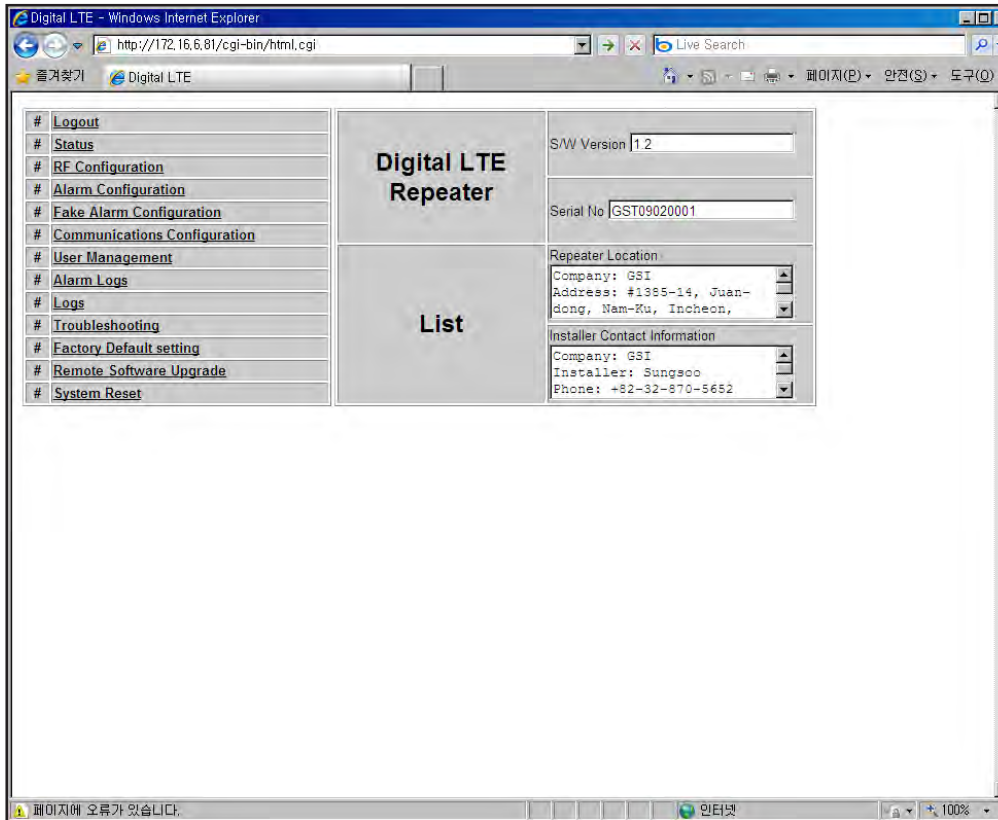

Setup Wizard

- Menu Select Page after logging
- Click “ Initial Installation” for Setup Wizard phase
- Waiting Time: Real-time

Menu Select

Initial Installation

Main Page

Setup Wizard

- Repeater Location setting
- Click “Apply” for updating
- Click “Skip” without any renewal
- Waiting Time: Real-time

Setup Wizard

Repeater Location	
Company	<input type="text" value="GSI"/>
Address	<input type="text" value="#1385-14, Juan-dong, Nam-Ku, Incheon, Korea"/>
City, State, Zip	<input type="text" value="Incheon, Korea, 402-200"/>
<input type="button" value="Apply"/> <input type="button" value="Skip"/>	

Setup Wizard

- Installer Contact Information setting
- Click “Apply” for updating
- Click “Skip” without any modification
- Waiting Time: Real-time

Setup Wizard

Installer Contact Information	
Company	<input type="text" value="GSI"/>
Installer	<input type="text" value="Sungsoo Lee"/>
Phone	<input type="text" value="+82-32-870-5652"/>
E-Mail	<input type="text" value="ssleedev@gsinstrument.com"/>
<input type="button" value="Apply"/> <input type="button" value="Skip"/>	

Setup Wizard

- LTE Band Select Configuration setting
- Click “Apply” for updating
- Click “Skip” without any modification
- Waiting Time: Real-time

Setup Wizard

The screenshot shows a dialog box titled "LTE Band Select Configuration" with a sub-header "COMMON". The dialog contains a "Band Select" label, a dropdown menu, a checkbox, and "Apply" and "Skip" buttons. The dropdown menu is open, showing the following options: A, Filter OFF, A, B, A+B, C, A+C, B+C, and A+B+C. The "A" option is currently selected and highlighted in blue. The checkbox is unchecked.

Setup Wizard

- Antenna Setting Control setting
- Click “Apply” for updating
- Click “Skip” without any modification
- Waiting Time: Real-time

Setup Wizard

Antenna Setting Control

Antenna Only (AGS Setting) ▾

Antenna Only (AGS Setting)

DAS (ALC downlink limit 7 dBm Setting)

DAS (ALC downlink limit Maximum Setting)

Not Use (HPA OFF)

Apply Skip

Setup Wizard

- Waiting (Operating) Time:
 - Typical: 3mins
 - Maximum: 5mins



CAUTION

Please make Path On when you run Setup Wizard if Path Off set

Setup Wizard

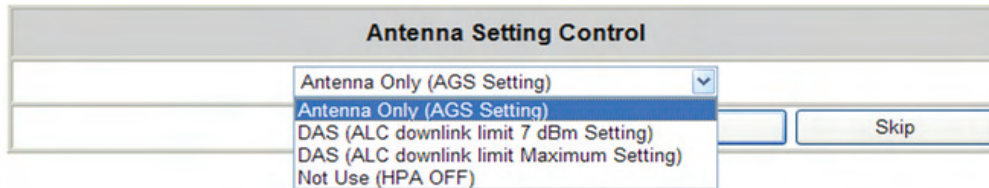

1. Antenna only (AGS setting) is for Auto Gain Setting to optimize this repeater for field conditions
 - a. Every limit level (AGC, Down/Uplink ALC) is normal (example : Standard output power)
 - b. Auto Gain Setting will run
2. DAS (ALC downlink Limit 7dBm Setting) option is used for connecting this repeater to DAS equipment (LGC DAS, Mobile Access DAS etc), and following condition should be controlled.
 - a. AGC turn Off
 - b. ALC turn On
 - c. Gain Balance turn Off
 - d. ALC downlink limit value set +7dBm
 - e. ALC uplink limit value set normal output power (example : Standard output power)
 - f. Shut down turn On
 - g. HPA turn On, If HPA turn off
 - h. delay alarm reporting time set 5 min
3. DAS (ALC downlink Limit Maximum Setting) option is used for connecting Passive DAS equipment, and 7dB downlink limit value is set as normal output power level (Example: Standard output power)

Status Page

- Default D/L and U/L are set at minimum Gain.
- The default values in various fields will differ with different models of CoverCell25K/100K700 Repeaters.
- In order to view other pages, you can click the desired menu on the top-left corner of all pages.
- Changes can be made on the Status Page. This page is for checking the repeater's conditions and settings.

The screenshot shows a web browser window titled "Digital LTE - Windows Internet Explorer" with the URL "http://172.16.6.81/cgi-bin/html.cgi?function=status". The page content is as follows:

Digital LTE Repeater

Status

S/W Version: 1.2

Serial No: GST09020001

Repeater Location:

Company: GSI
Address: #1395-14, Juandong, Nam-Ku, Incheon,

Installer Contact Information:

Company: GSI
Installer: Sungsoo
Phone: +82-32-870-5652

RF Status

COMMON

Temperature	62.6	°F	Temperature Upper Limit	185.0	°F
Temperature Lower Limit	10.4	°F	Alarm Delay	ON	
Shutdown ON/OFF	ON		Always Isolation ON/OFF	OFF	
AGS ON/OFF	OFF		Band Select	A	Band
Path ON/OFF	OFF		Gain Balance Offset	0.0	dB
Gain Balance ON/OFF	OFF				

Downlink		Uplink			
RSSI Power	-20	dBm			
Output Power	3.5	dBm	Output Power	-20	dBm

Status Page

- When an alarm goes off, the color of Status turns red.

Digital LTE - Windows Internet Explorer
 http://172.16.6.81/cgi-bin/html.cgi?function=status

B Band Gain Offset	0.0	dB	B Band Gain Offset	0.0	dB
C Band Gain Offset	0.0	dB	C Band Gain Offset	0.0	dB
AB Band Gain Offset	0.0	dB	AB Band Gain Offset	0.0	dB

Alarm Status

Fake Alarm Mode ON/OFF:

COMMON

Status	Name	Status	Name
Green	Temperature Lower Limit	Green	Temperature Upper Limit
Green	Tamper Detected	Green	Power Supply Out Of Range
Green	Communication Failure	Green	Field Replaceable Module Failure
Green	Reset Alarm	Green	Manual Shutdown Alarm
Green	Heartbeat		

Downlink		Uplink	
Status	Name	Status	Name
Green	Low Isolation	Green	Oscillation Detected
Green	Donor Power Too High/Low	Green	Power At Coverage Port Too High
Green	Synthesizer Failure	Green	Synthesizer Failure
Green	Hardware Failure	Green	Hardware Failure
Green	Software Failure	Green	Software Failure
Green	Spurious Emissions Out Of Specification	Green	Out Of band Emissions Out Of Specification
Green	Interferer Power Exceeded		
Green	VSWR Alarm	Green	VSWR Alarm

Communications Configuration

- Click on the Communications Configuration link.

The screenshot shows a web browser window titled "Digital LTE - Windows Internet Explorer" with the address bar displaying "http://172.16.6.81/cgi-bin/html.cgi?function=communications". The page content is organized into several sections:

- Left Navigation Menu:** A vertical list of menu items including # Logout, # Status, # RF Configuration, # Alarm Configuration, # Fake Alarm Configuration, # Communications Configuration (highlighted), # User Management, # Alarm Logs, # Logs, # Troubleshooting, # Factory Default setting, # Remote Software Upgrade, and # System Reset.
- Header Section:** Contains the text "Digital LTE Repeater" and "Communications Configuration".
- Form Fields:** Includes "S/W Version" (1.2), "Serial No" (GST09020001), "Repeater Location" (Company: GSI, Address: #1385-14, Jundong, Nam-Ru, Incheon), and "Installer Contact Information" (Company: GSI, Installer: Sungsoo, Phone: +82-32-870-5652).
- SNMP Configuration Table:**

SNMP Community	public
SNMP Port	161
Longitude : Latitude <small>ex) N S 000.000000 E W 000.000000</small>	N/S 751.076421
Current Time <small>ex) month/day_hour min_year</small>	02 / 14 / 01 40 / 2010 05/31_16:59_2007
- Buttons:** An "Apply" button is located at the bottom left of the configuration area.

RF Configuration

- Click the RF Configuration link.
- This menu is where installer will actually configure the Repeater.
- You can change various RF values of the equipment on this page.

Digital LTE Repeater

RF Configuration

S/W Version: 1.2

Serial No: GST09020001

Repeater Location
 Company: GSI
 Address: #1385-14, Juandong, Nam-Ku, Incheon,

Installer Contact Information
 Company: GSI
 Installer: Sungsoo
 Phone: +82-32-870-5652

COMMON

Temperature Up Limit	185.0 °F	<input type="checkbox"/>	Temperature Down Limit	10.4 °F	<input type="checkbox"/>
Alarm delay ON/OFF	ON	<input type="checkbox"/>	Shutdown ON/OFF	ON	<input type="checkbox"/>
Always Isolation ON/OFF	OFF	<input type="checkbox"/>	AGS ON/OFF	OFF	<input type="checkbox"/>
Band Select	A	<input type="checkbox"/>	PATH ON/OFF	OFF	<input type="checkbox"/>
Gain Balance ON/OFF	OFF	<input type="checkbox"/>	Gain Balance Offset	0.0 dB	<input type="checkbox"/>
Downlink			Uplink		
AGC ON/OFF	ON	<input type="checkbox"/>			
AGC Limit Level	23.5 dBm	<input type="checkbox"/>	ALC Limit Level	20.0 dBm	<input type="checkbox"/>
ATT	0.0 dB	<input type="checkbox"/>	ATT	0.0 dB	<input type="checkbox"/>
PAM ON/OFF	OFF	<input type="checkbox"/>	PAM ON/OFF	OFF	<input type="checkbox"/>
A Band Gain Offset	0.0 dB	<input type="checkbox"/>	A Band Gain Offset	0.0 dB	<input type="checkbox"/>
B Band Gain Offset	0.0 dB	<input type="checkbox"/>	B Band Gain Offset	0.0 dB	<input type="checkbox"/>

RF Configuration

- In case that screen resolution is 1024 x 768, you may need to use scroll bars to view all.
- Changes will not take effect until you click “Apply” button.
- The default values in various fields will differ with different models of CoverCell25K/100K700 Repeaters.

RF Configuration

Company: GSI
Address: #1385-14, Juan-dong, Nam-Ku, Incheon,

Installer Contact Information
Company: GSI
Installer: Sungsoo
Phone: +82-32-870-5652

COMMON			
Temperature Up Limit	185.0	'F	<input type="checkbox"/>
Temperature Down Limit	10.4	'F	<input type="checkbox"/>
Alarm delay ON/OFF	ON		<input type="checkbox"/>
Shutdown ON/OFF	ON		<input type="checkbox"/>
Always Isolation ON/OFF	OFF		<input type="checkbox"/>
AGS ON/OFF	OFF		<input type="checkbox"/>
Band Select	A		<input type="checkbox"/>
PATH ON/OFF	OFF		<input type="checkbox"/>
Gain Balance ON/OFF	OFF		<input type="checkbox"/>
Gain Balance Offset	0.0	dB	<input type="checkbox"/>
Downlink		Uplink	
AGC ON/OFF	ON		<input type="checkbox"/>
AGC Limit Level	23.5	dBm	<input type="checkbox"/>
ALC Limit Level	20.0	dBm	<input type="checkbox"/>
ATT	0.0	dB	<input type="checkbox"/>
ATT	0.0	dB	<input type="checkbox"/>
PAM ON/OFF	OFF		<input type="checkbox"/>
PAM ON/OFF	OFF		<input type="checkbox"/>
A Band Gain Offset	0.0	dB	<input type="checkbox"/>
A Band Gain Offset	0.0	dB	<input type="checkbox"/>
B Band Gain Offset	0.0	dB	<input type="checkbox"/>
B Band Gain Offset	0.0	dB	<input type="checkbox"/>
C Band Gain Offset	0.0	dB	<input type="checkbox"/>
C Band Gain Offset	0.0	dB	<input type="checkbox"/>
AB Band Gain Offset	0.0	dB	<input type="checkbox"/>
AB Band Gain Offset	0.0	dB	<input type="checkbox"/>

Apply

Bandwidth and Frequency Selection

1. Login as admin as above.

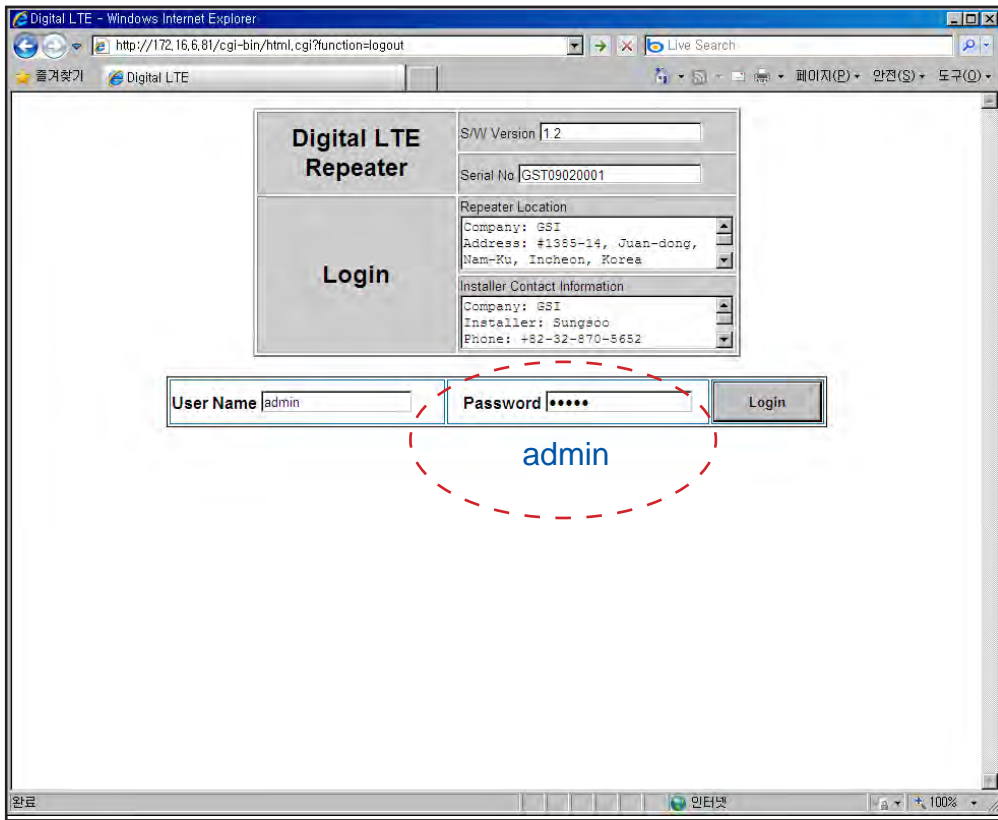

Bandwidth and Frequency Selection

2. Click RF configuration

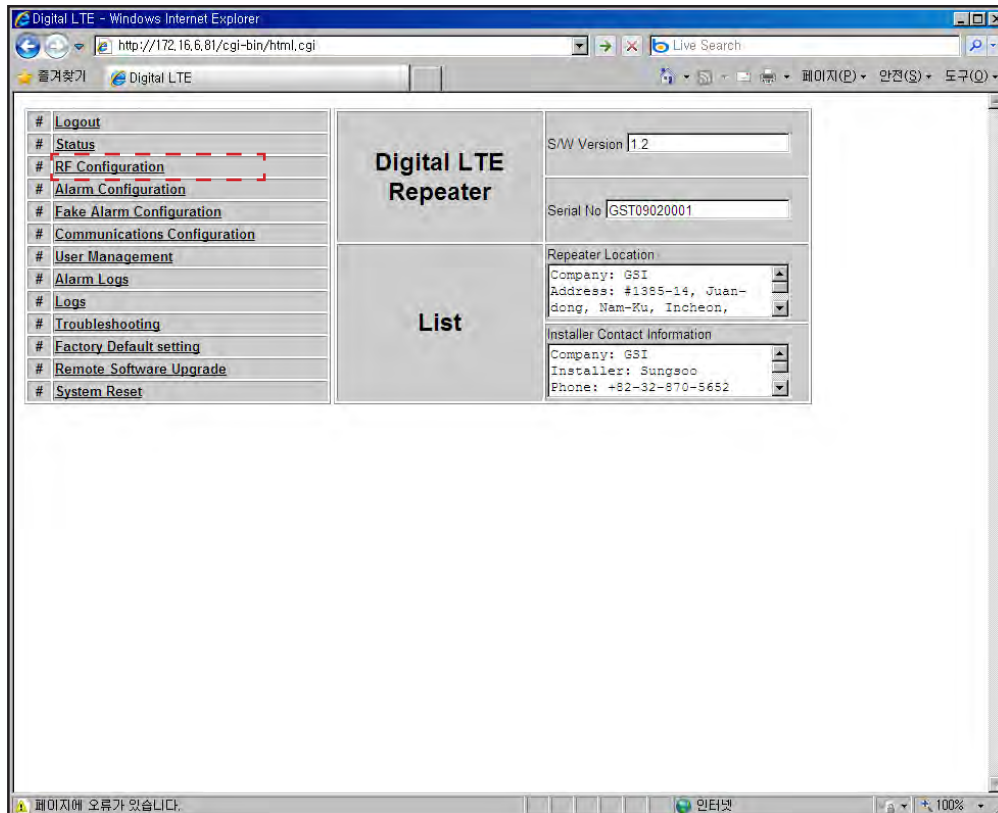

Bandwidth and Frequency Selection

3. Choose Bandwidth and select bandwidth users want.

Depending on the bandwidth, the frequency will be set accordingly

The screenshot displays the 'Digital LTE Repeater' configuration interface. The browser window shows the URL 'http://172.16.6.81/cgi-bin/html.cgi?function=rfconfiguration'. The page title is 'Digital LTE Repeater'. A left sidebar contains a menu with options like Logout, Status, RF Configuration, Alarm Configuration, Fake Alarm Configuration, Communications Configuration, User Management, Alarm Logs, Logs, Troubleshooting, Factory Default setting, Remote Software Upgrade, and System Reset. The main content area is titled 'RF Configuration' and includes fields for S/W Version (1.2), Serial No (GST09020001), Repeater Location (Company: GSI, Address: #1388-14, Juandong, Nam-Ku, Incheon), and Installer Contact Information (Company: GSI, Installer: Sungsoo, Phone: +82-32-870-5652). Below this is a 'COMMON' configuration table with various parameters like Temperature Up/Down Limits, Alarm delay, Band Select, Gain Balance, AGC, ATT, and PAM. The 'Band Select' dropdown menu is open, showing options A, B, A+B, C, A+C, B+C, and A+B+C. A red dashed box highlights the 'Filter OFF' option in the dropdown.

COMMON			
Temperature Up Limit	185.0 °F	Temperature Down Limit	10.4 °F
Alarm delay ON/OFF	ON	Shutdown ON/OFF	ON
Always Isolation ON/OFF	OFF	AGS ON/OFF	OFF
Band Select	A	PATH ON/OFF	OFF
Gain Balance ON/OFF	Filter OFF	Gain Balance Offset	0.0 dB
AGC ON/OFF	Down	Uplink	
AGC Limit Level	A	ALC Limit Level	20.0 dBm
ATT	0.0 dB	ATT	0.0 dB
PAM ON/OFF	OFF	PAM ON/OFF	OFF
A Band Gain Offset	0.0 dB	A Band Gain Offset	0.0 dB
B Band Gain Offset	0.0 dB	B Band Gain Offset	0.0 dB

Bandwidth and Frequency Selection

6. Click Apply if all the setting is done.

Please set AGS "ON", CoverCell25K/100K700 will remember the status of AGS and perform AGS on rebooting.

The screenshot shows the 'RF Configuration' web page. The 'COMMON' section contains the following settings:

COMMON					
Temperature Up Limit	185.0 °F	<input type="checkbox"/>	Temperature Down Limit	10.4 °F	<input type="checkbox"/>
Alarm delay ON/OFF	ON	<input type="checkbox"/>	Shutdown ON/OFF	ON	<input type="checkbox"/>
Always Isolation ON/OFF	OFF	<input type="checkbox"/>	AGS ON/OFF	OFF	<input type="checkbox"/>
Band Select	A	<input type="checkbox"/>	PATH ON/OFF	OFF	<input type="checkbox"/>
Gain Balance ON/OFF	OFF	<input type="checkbox"/>	Gain Balance Offset	0.0 dB	<input type="checkbox"/>
Downlink		Uplink			
AGC ON/OFF	ON				
AGC Limit Level	23.5 dBm	ALC Limit Level	20.0 dBm		
ATT	0.0 dB	ATT	0.0 dB		
PAM ON/OFF	OFF	PAM ON/OFF	OFF		
A Band Gain Offset	0.0 dB	A Band Gain Offset	0.0 dB		
B Band Gain Offset	0.0 dB	B Band Gain Offset	0.0 dB		
C Band Gain Offset	0.0 dB	C Band Gain Offset	0.0 dB		
AB Band Gain Offset	0.0 dB	AB Band Gain Offset	0.0 dB		

The 'Apply' button is located at the bottom left of the configuration area.

RavenX Setting

- RavenX is not supplied with Repeater and can be purchased separately from Kentrox.
- An antenna or antenna cable should be connected to “Primary Cellular” port in Figure 13.
- One end of an ethernet cable should be connected to “Ethernet” in Figure 1, the other end should be connected to WAN port in CoverCell25K/100K700.
- Power should be connected to “Power” in Figure 1. Power supply is provided with RavenX.
- RavenX will work with CoverCell25K/100K700 with its default setting.

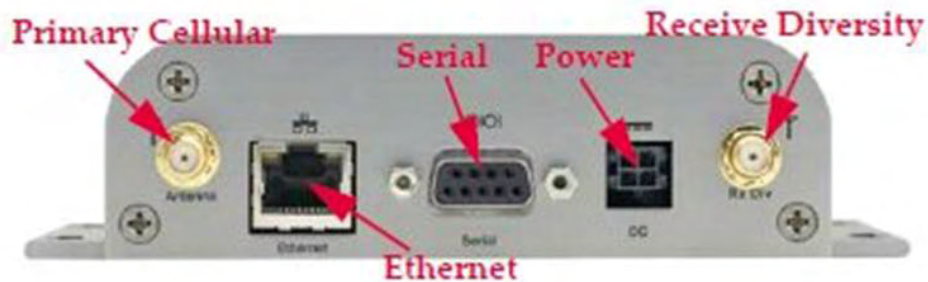

<Figure 13> RavenX Setting

- RavenX will work with CoverCell25K/100K700 with its default setting.

Alarm Configuration

- Click Alarm Configuration link.
- In case that Report Alarms is OFF, all alarms will be disabled. In case that Report Alarm is ON, you can enable and disable individual alarms.

The screenshot displays the 'Alarm Configuration' page for a Digital LTE Repeater. The interface includes a navigation menu on the left with options like Logout, Status, RF Configuration, Alarm Configuration, Fake Alarm Configuration, Communications Configuration, User Management, Alarm Logs, Logs, Troubleshooting, Factory Default setting, Remote Software Upgrade, and System Reset. The main content area is titled 'Digital LTE Repeater Alarm Configuration' and contains several configuration fields: S/W Version (1.2), Serial No (GST09020001), Repeater Location (Company: GSI, Address: #1385-14, Juan-dong, Nam-Ru, Incheon), and Installer Contact Information (Company: GSI, Installer: Sungsoo, Phone: +82-92-870-5652). A 'Report Alarms' dropdown menu is currently set to 'ON'. Below this, there is a section for 'SNMP Alarm' with a 'COMMON' sub-section. This section contains a table of alarm configurations.

SNMP Alarm					
COMMON					
No	Name	State	Active	Last Triggered	SNMP Mapping
0	Tamper Detected	Alarm	Enable	Sun Feb 14 01:43:28 2010	Tamper Detected
1	Power Supply Out Of Range	Normal	Enable	Sun Feb 14 01:38:23 2010	Power Supply Out Of Range
2	Communication Failure	Normal	Enable	Sun Feb 14 01:38:23 2010	Communication Failure
3	Field Replaceable Module Failure	Normal	Enable	Sun Feb 14 01:38:23 2010	Field Replaceable Module Failure
4	Reset Alarm	Normal	Enable	Sun Feb 14 01:39:28 2010	Reset Alarm

Alarm Configuration

- In case that screen resolution is 1024 x 768, you may need to use scroll bars to view all. Changes will not be made effective until you click “Apply” button.

Digital LTE - Windows Internet Explorer
 http://172.16.6.81/cgi-bin/html.cgi?function=alarm

16	Downlink Hardware Failure	Normal	Enable	Sun Feb 14 01:38:23 2010	Downlink Hardware Failure
17	Downlink Software Failure	Alarm	Enable	Sun Feb 14 01:43:28 2010	Downlink Software Failure
18	Downlink Spurious Emissions Out Of Specification	Normal	Enable	Sun Feb 14 01:38:23 2010	Downlink Spurious Emissions Out Of Specification
19	Downlink Interferer Power Exceeded	Normal	Enable	Sun Feb 14 01:38:23 2010	Downlink Interferer Power Exceeded

General Alarm

COMMON

No	Name	State	Active	Last Triggered	SNMP Mapping
20	Temperature Upper Limit Alarm	Normal	Enable	Sun Feb 14 01:38:23 2010	Not Used
21	Temperature Lower Limit Alarm	Normal	Enable	Sun Feb 14 01:38:23 2010	Not Used

Uplink

No	Name	State	Active	Last Triggered	SNMP Mapping
22	VSWR Alarm	Normal	Enable	Sun Feb 14 01:38:23 2010	Not Used

Downlink

No	Name	State	Active	Last Triggered	SNMP Mapping
23	VSWR Alarm	Normal	Enable	Sun Feb 14 01:38:23 2010	Not Used

Apply

Alarm List

Category	Alarm
General	Tamper
	Power Supply out of range
	Communication
	Field replaceable module Fail
	Reset alarm
	Manual shutdown alarm
	Heart beat
Uplink	OSC detect
	Power at CVG port too high
	Synthesizer Fail
	Hardware Fail
	Software Fail
	Out of Band emission
Downlink	Donor power too high/low
	Low isolation
	Synthesizer Fail
	Hardware Fail
	Software Fail
	Spurious emission
	Interferer power exceed

User Management

- Click on the User Management link.
- On this page you can create and delete users, change passwords, and assign authorities to individual users.
- Read/Write Authority means that the user can change various values.
- Super User is very similar to an Administrator account.



CAUTION

DO NOT DELETE 'admin'

Digital LTE - Windows Internet Explorer
 http://172.16.6.81/cgi-bin/html.cgi?function=usermanagement

Digital LTE

Logout
 # Status
 # RF Configuration
 # Alarm Configuration
 # Fake Alarm Configuration
 # Communications Configuration
 # **User Management**
 # Alarm Logs
 # Logs
 # Troubleshooting
 # Factory Default setting
 # Remote Software Upgrade
 # System Reset

Digital LTE Repeater

S/W Version 1.2
 Serial No GST09020001

User Management

Repeater Location
 Company: GSI
 Address: #1385-14, Juandong, Nam-Ku, Incheon,
 Installer Contact Information
 Company: GSI
 Installer: Sungsoo
 Phone: +82-32-870-5652

User Must be 5-8 characters
 Password Must be 5-8 characters
 Password confirm
 Authority

Register Reset

admin	
-------	--

Delete

Alarm Logs

- Click on the Alarm Logs link.
- You can see Alarm Logs regarding Web UI operation. Alarm Logs will maintain a history of up to 30 operations.

Number	Name	Status	Last Triggered
1	Manual Shutdown Alarm	Active	02/14/2010 01:44:12
2	Manual Shutdown Alarm	Active	02/14/2010 01:44:02
3	Manual Shutdown Alarm	Active	02/14/2010 01:43:52
4	Manual Shutdown Alarm	Active	02/14/2010 01:43:42
5	Manual Shutdown Alarm	Active	02/14/2010 01:43:31
6	Downlink Donor Power Too High/Low	Active	02/14/2010 01:43:28
7	Tamper Detected	Active	02/14/2010 01:43:28
8	Reset Alarm	Active	02/14/2010 01:39:28
9	Uplink Software Failure	Active	02/14/2010 01:38:28
10	Uplink Power At Coverage Port Too High	Active	02/14/2010 01:38:28

Logs

- Click on the Alarm Logs link.
- You can see Alarm Logs regarding Web UI operation. Logs will maintain a history of up to 30 operations.

The screenshot shows the 'Digital LTE Repeater' web interface. The left sidebar contains a navigation menu with the following items: Logout, Status, RF Configuration, Alarm Configuration, Fake Alarm Configuration, Communications Configuration, User Management, Alarm Logs, Logs, Troubleshooting, Factory Default setting, Remote Software Upgrade, and System Reset. The 'Logs' link is highlighted.

The main content area is titled 'Digital LTE Repeater' and 'Logs'. It displays system information: S/W Version 1.2, Serial No GST09020001, Repeater Location (Company: GSI, Address: #1395-14, Juandong, Nam-Ku, Incheon), and Installer Contact Information (Company: GSI, Installer: Sungsoo, Phone: +82-32-870-5652).

Below the system information is a table of logs:

Date & Time	User	Operation	Description
02/14/2010 - 01:49:47	admin	Alarm Logs	Checked
02/14/2010 - 01:49:24	admin	User Management	Accessed
02/14/2010 - 01:48:36	admin	Alarm Configuration	Checked
02/14/2010 - 01:43:40	admin	RF Configuration	Checked
02/14/2010 - 01:43:39	admin	Login	Login
02/14/2010 - 01:41:42	admin	Logout	Logout
02/14/2010 - 01:40:46	admin	RF Configuration	Checked
02/14/2010 - 01:40:19	admin	Communications	Checked
02/14/2010 - 01:40:17	admin	Login	Login
02/14/2010 - 01:38:00	admin	Communications	Set
02/14/2036 - 01:39:19	admin	Troubleshooting	Checked
02/14/2036 - 01:39:19	admin	Troubleshooting	Checked
02/14/2036 - 01:38:51	admin	Communications	Checked

Troubleshooting Guide

- Click on the Troubleshooting link.
- You can refer to this page for a general troubleshooting guide.
- In case that screen resolution is 1024 x 768, you may need to use scroll bars to view all.

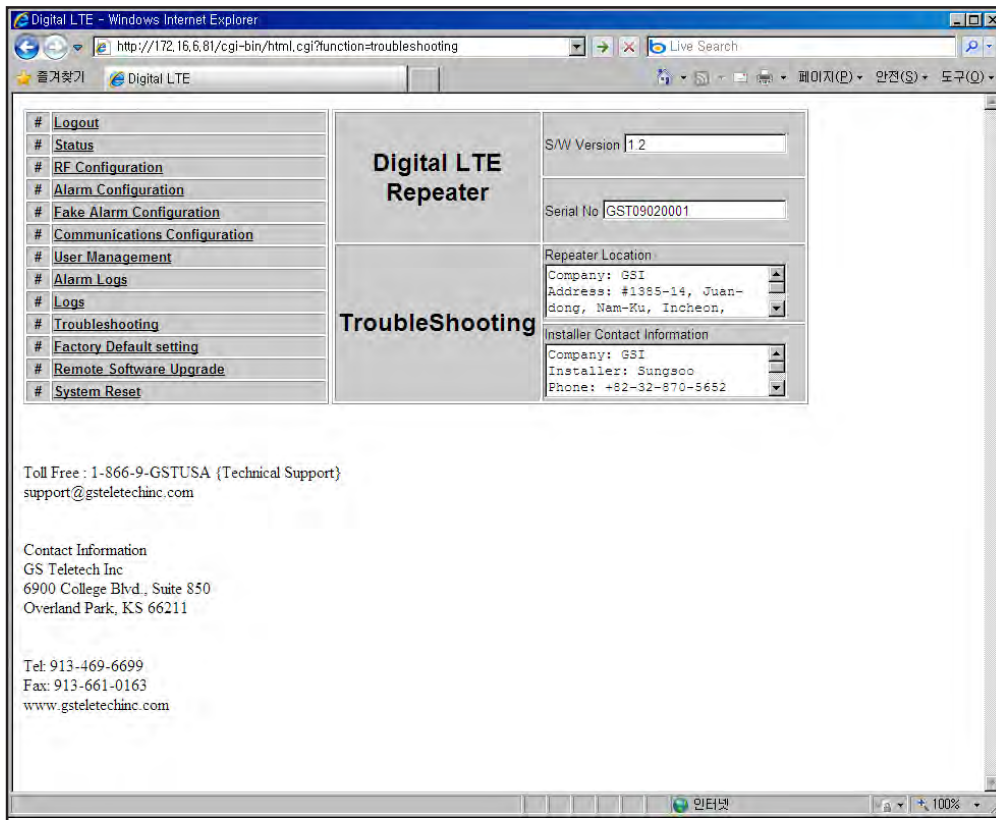

Troubleshooting

- Please click “Main Page” on Menu Select Page after logging.

Menu Select

Initial Installation

Main Page

Troubleshooting

- “Troubleshooting” Click

# Logout	Digital LTE Repeater	S/W Version 1.6
# Status		Serial No GST09020001
# RF Configuration	TroubleShooting	Repeater Location
# Alarm Configuration		Company: GSI
# Fake Alarm Configuration		Address: #1385-14, Juan-dong, Nam-Ku, Incheon,
# Communications Configuration		Installer Contact Information
# User Management		Company: GSI
# Alarm Logs		Installer: Sungsoo Lee
# Logs		Phone: +82-32-870-5652
# Troubleshooting		
# Factory Default set		
# Remote Software Upgrade		
# System Reset		

Temperature up limit alarm	1. Check maximum temperature level 2. Check repeater's environment conditions
Temperature down limit alarm	1. Check minimum temperature level 2. Check repeater's environment conditions
Voltage out range alarm	1. Check data cable 2. Power supply replacement
Current out alarm	1. Check data cable 2. Drive Unit replacement 3. Power supply replacement
Power supply alarm	1. Check data cable 2. Power supply replacement
Signal not detect alarm	1. Check input signal 2. Drive Unit replacement
Signal low alarm	1. Check input signal 2. Drive Unit replacement
Out of band signal overdrive alarm	1. ANT positioning 2. Drive Unit replacement
Isolation alarm	1. Check setup level 2. Reboot repeater 3. Check setup ANT 4. NMS Unit replacement
Synthesize fail alarm	1. Drive Unit replacement 2. NMS Unit replacement
Over output power	1. Check setup level 2. Reset default values 3. Reboot repeater 4. NMS Unit replacement
VSWR alarm	1. Reboot repeater 2. Check coverage ANT connection 3. Drive Unit replacement

Troubleshooting

- **Temperature up limit alarm**
 - Check maximum temperature level
 - Check repeater's environment conditions

- **Temperature down limit alarm**
 - Check minimum temperature level
 - Check repeater's environment conditions

- **Voltage out range alarm**
 - Check data cable
 - Power supply replacement

- **Current out alarm**
 - Check data cable
 - Drive Unit replacement
 - Power supply replacement

- **Power supply alarm**
 - Check data cable
 - Power supply replacement

- **Signal not detect alarm**
 - Check input signal
 - Drive Unit replacement

- **Signal low alarm**
 - Check input signal
 - Drive Unit replacement

Troubleshooting

- **Out of band signal overdrive alarm**

- ANT positioning
- Drive Unit replacement

- **Isolation alarm**

- Check setup level
- Reboot repeater
- Check setup ANT
- NMS Unit replacement

- **Synthesize fail alarm**

- Drive Unit replacement
- NMS Unit replacement

- **Over output power**

- Check setup level
- Reset default values
- Reboot repeater
- NMS Unit replacement

- **VSWR alarm**

- Reboot repeater
- Check coverage ANT connection
- Drive Unit replacement

Software Upgrade

- Click on the Remote Software Upgrade link.
- In case that software upgrade is needed, you should use this page.
- Click Browse button to select the file to upgrade from the laptop.

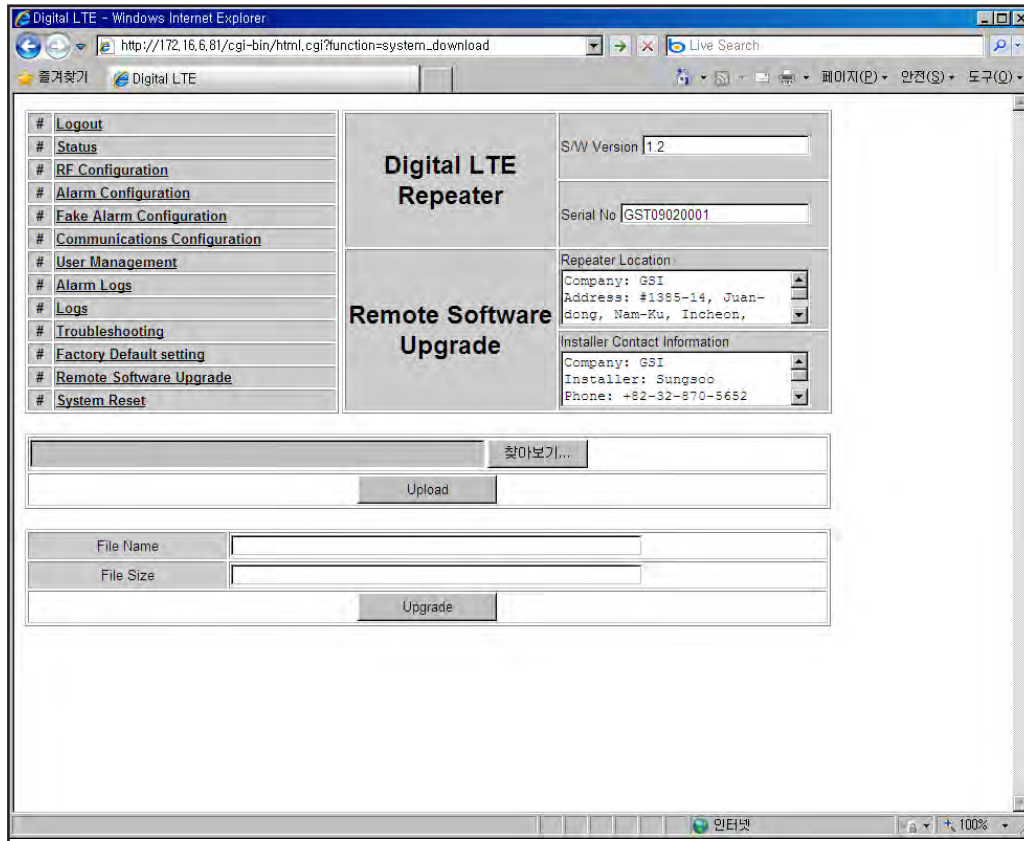

Software Upgrade

- Choose the file to upgrade provided by GST.
After you choose the file, you should click “upload” to send the file from your laptop to the repeater.



CAUTION

Be careful not to unplug the crossover Ethernet cable during software upgrade.

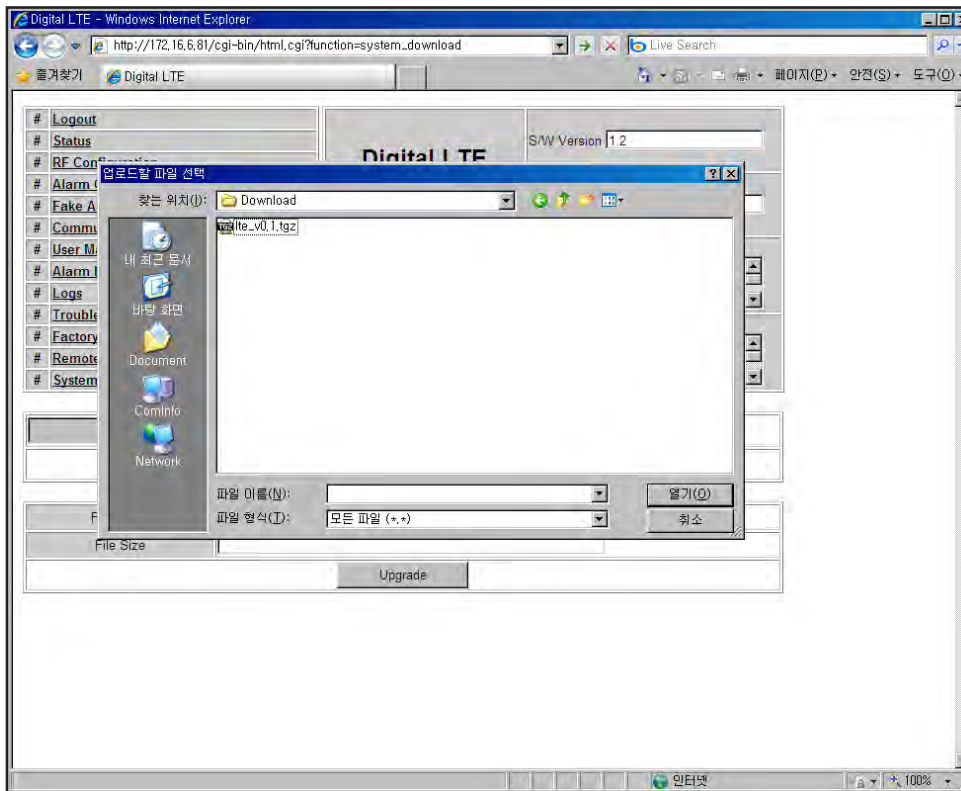

Software Upgrade

- After uploading is finished, verify that the File Name and the File Size is correct, click “Upgrade” button. Installer should wait about 2 minutes for upgrade to initialize.
- User may then be prompted to log back into the Repeater.

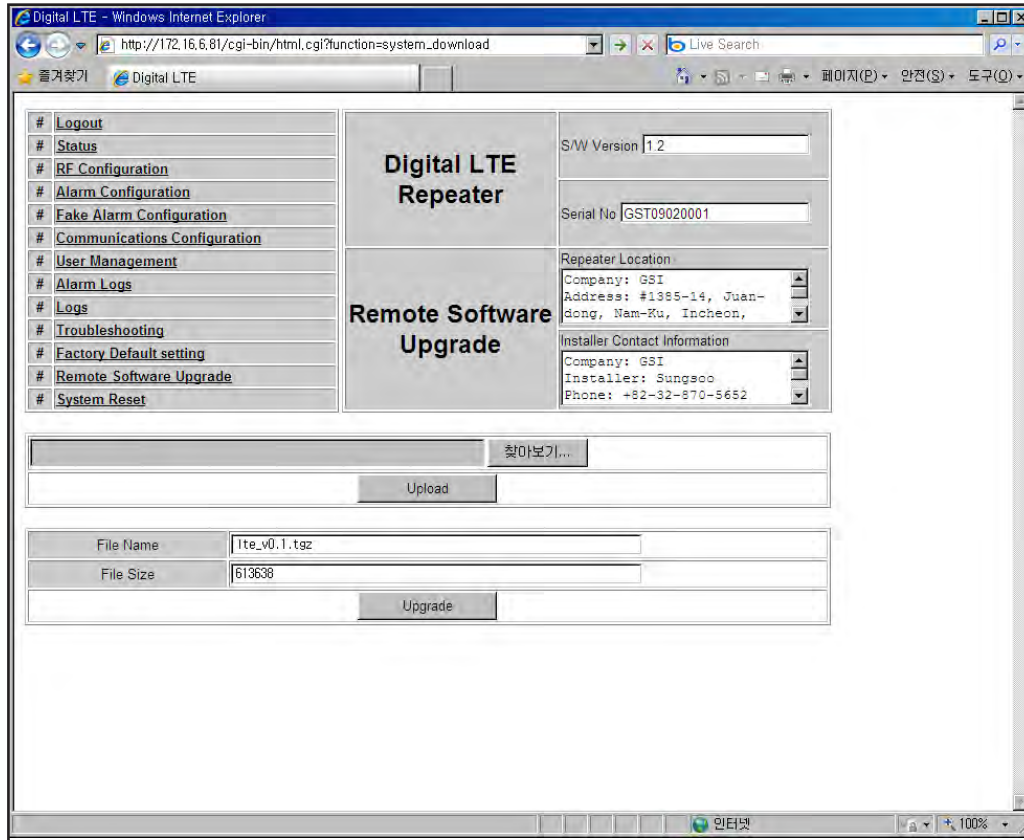

System Reset

- A software reset is a “soft reboot” of the repeater.
To reset the software, click on ‘Software Reset’ and then click ‘Yes’ to reset the software.
- Resetting the software is a good way to clear current alarms.

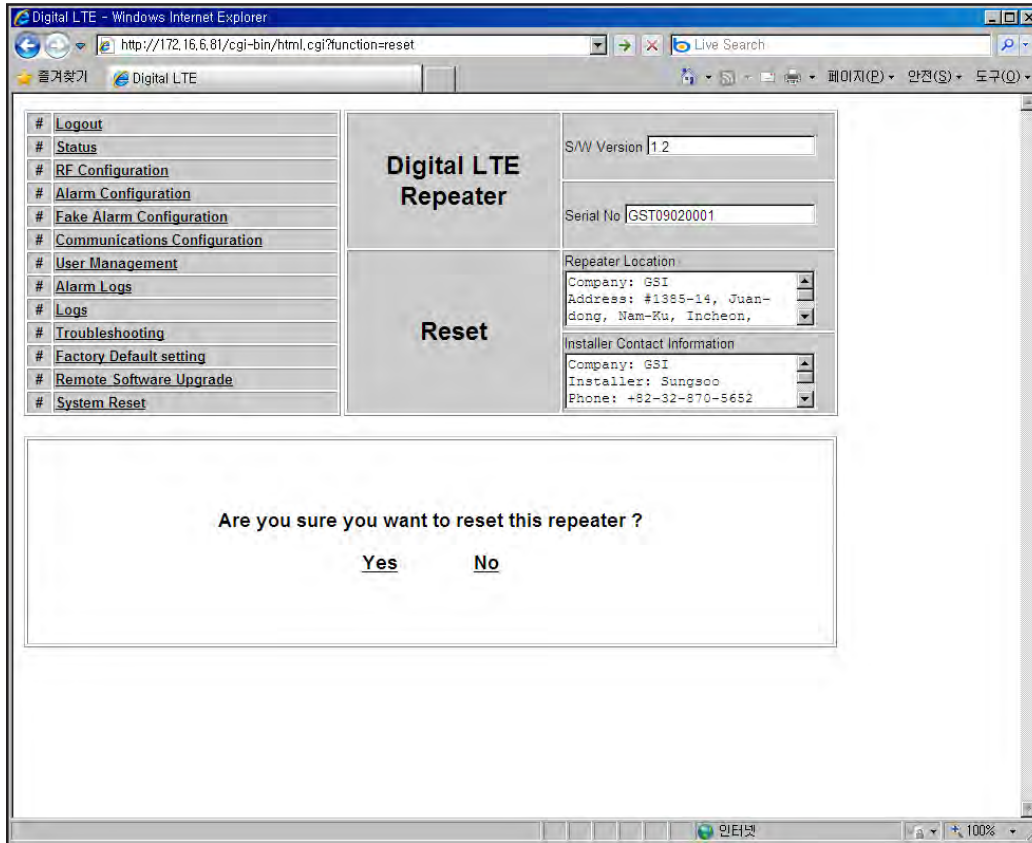

GST Technical Support

Phone:

Toll Free: 1-866-9-GST-USA

Phone: 913-469-6699



Write:

GS Teletech Inc.

6900 College Boulevard, Suite 850

Overland Park, KS 66211, USA



Product Information and Technical Assistance:

www.gsteletechinc.com

support@gsteletechinc.com



Specifications and features of this installation guide are subject to change without notice or obligation.



Warning: Exposure to Radio Frequency Radiation The radiated output power of this device is far below the FCC radio frequency exposure limits. Nevertheless, the device should be used in such a manner that the potential for human contact during normal operation is minimized. In order to avoid the possibility of exceeding the FCC radio frequency exposure limits, human proximity to the antenna should not be less than 40cm during normal operation. The gain of the antenna is 8 dBi. The antenna(s) used for this transmitter must not be co-located or operating in conjunction with any other antenna or transmitter.

Global IT Leader

GST