

ATTACHMENT E.

- USER MANUAL -

HCT CO., LTD.

SAN 136-1, AMI-RI, BUBAL-EUP, ICHEON-SI, KYOUNGKI-DO, 467-701, KOREA
TEL:+82 31 639 8517 FAX:+82 31 639 8525 www.hct.co.kr

SPRINT User Manual WIMAX_24dBm

July, 2008

Version 1.0

- INDEX -

1. SUMMARY 3

GSTR-2624D-SPR is an in-building solution for extending and improving WiMAX coverage area in Sprint network, providing better signal quality in small stores, manufacturing facilities, warehouses, etc. GSTR-2624D-SPR eliminates PN pollution to decreasing noise in Sprint's BTS. 3

2. SYSTEM STRUCTURE..... 4

2.1 Network structure for WIMAX Indoor RF Repeater 4

2.2 System Design and Operation 5

 2.2.1 System design..... 5

 2.2.2 Downlink Path..... 7

 2.2.3 Uplink Path 8

3. SPECIFICATIONS 9

3.1 System Specifications..... 9

3.2 Electrical and Environment Specifications 10

4. SET UP..... 11

4.1. Equipment needed for WIMAX RF Repeater Setup 11

 4.1.1 Notice..... 11

 4.1.2 System set up 12

4.2 Troubleshooting 12

 4.2.1 Necessary Testing and measuring equipment 12

 4.2.2 Notice..... 12

 4.2.3 Troubleshooting Guide..... 13

1. SUMMARY

GSTR-2624D-SPR is an in-building solution for extending and improving WiMAX coverage area in Sprint network, providing better signal quality in small stores, manufacturing facilities, warehouses, etc. GSTR-2624D-SPR eliminates PN pollution to decreasing noise in Sprint's BTS.

GRS-2624D-SPR Main Features

- Conversion type
- DNC/IF/UPC integration module is implemented.
- D/L & U/L S/W LNA
- Sync Detection Module achieved sync. Signal then process the sync signal.
- D/L ALC, U/L ALC function
- Gain Balance function to be interfaced with D/L and U/L Gain

Abbreviation

LNA: Low Noise Amplifier
PSU: Power Supply Unit
HPA: High Power Amplifier
SDM: Sync Detection Module



Caution: Replaceable batteries instruction

Risk of explosion if battery is replaced by an incorrect type.
Dispose of used batteries according to the instructions.

2. SYSTEM STRUCTURE

2.1 Network structure for WIMAX Indoor RF Repeater

Below picture shows a Network structure for WIMAX Indoor RF Repeater in a real site. Donor ANT takes a position on the direction to BTS which be linked, and Server ANT is available to be located in designated area for service by using RF cable deployments and dividers as blow.

One thing that we consider is Path losses between Repeater port and ANT in case of dividing by dividers and RF cables. They should be equally managed.

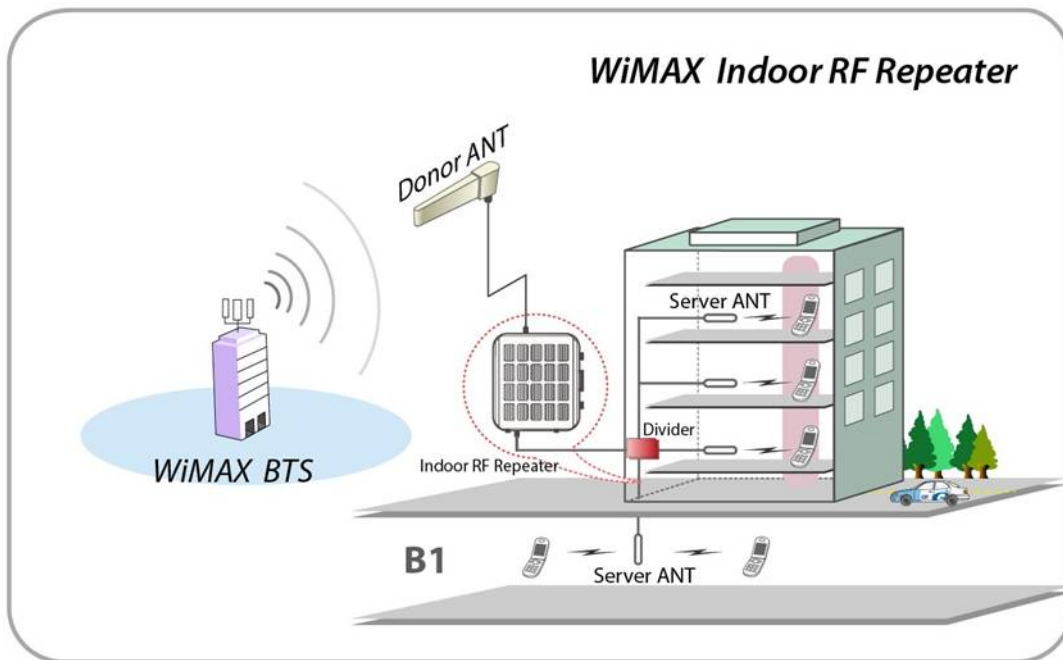

<Pic.1> WIMAX Indoor RF Repeater Service Organization

2.2 System Design and Operation

2.2.1 System design

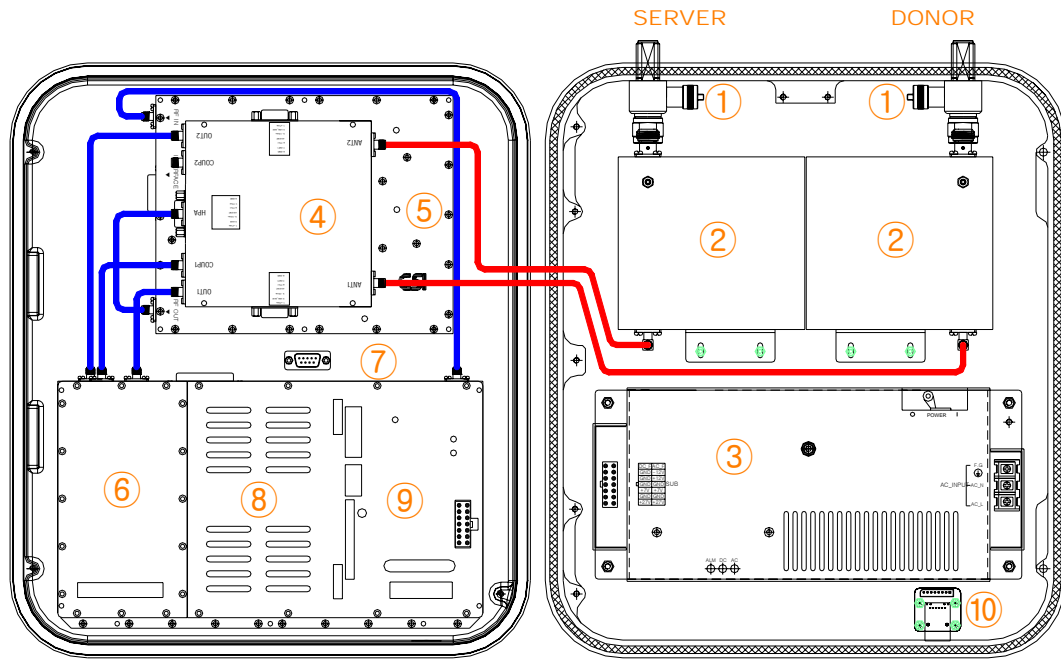

NO.	PART	NO.	PART
①	ARRESTOR	⑦	CONVERTER MODULE
②	CAVITY FILTER MODULE	⑧	NMS BOARD
③	PSU MODULE	⑨	I/O, RFC BOARD
④	LNA MODULE	⑩	ETHERNET PORT
⑤	HPA MODULE		
⑥	SDM MODULE		

<Pic.2> WIMAX Repeater 24dBm Internal Design

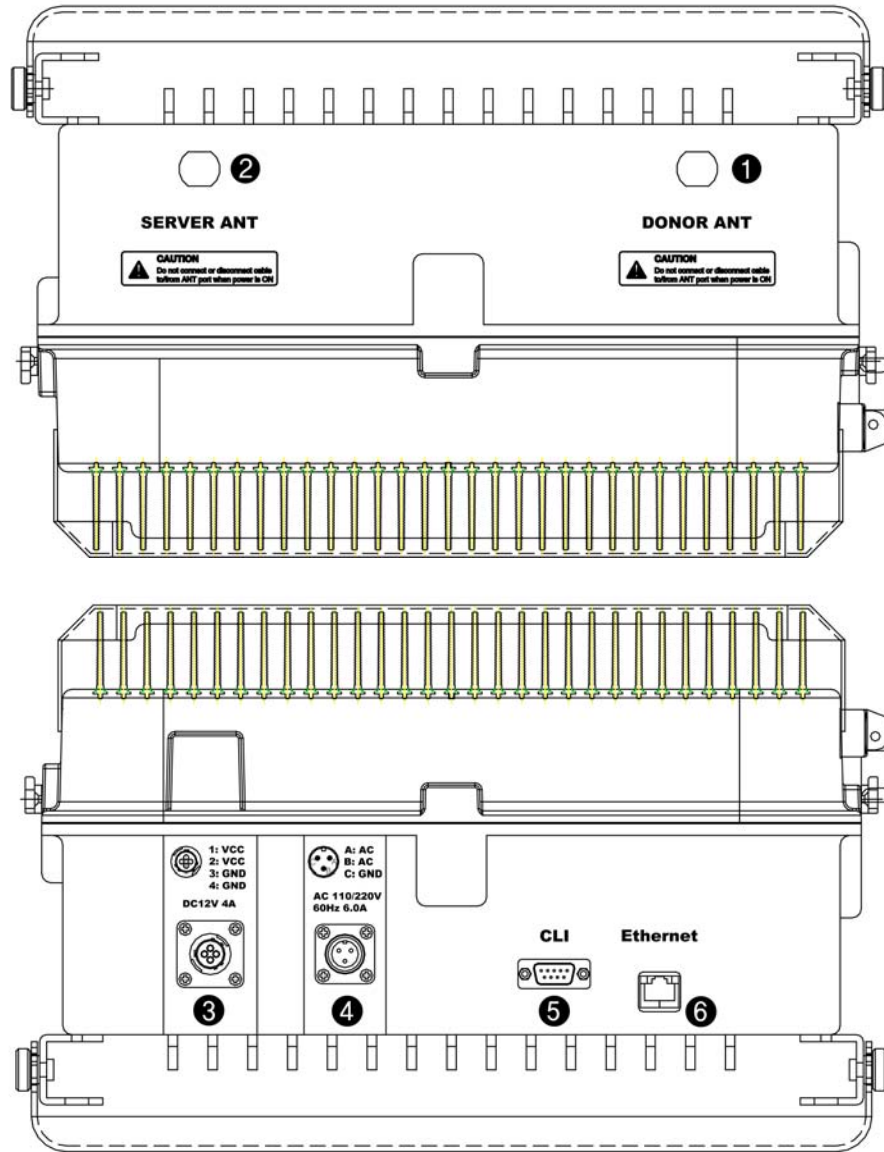

NO.	PORT	NO.	PORT
①	DONOR ANT PORT	④	AC POWER PORT
②	SERVER ANT PORT	⑤	CLI PORT
③	DC POWER PORT	⑥	ETHERNET PORT

<Pic.3> WIMAX Repeater 24dBm PORT Design

2.2.2 Downlink Path

GRS-2624D-SPR is basically designed to select 33MHz operational bandwidth from entire BRS bandwidth (188MHz). Repeater would smartly select actual Sprint operational bandwidth such as 2502~2568MHz (ABCD), 2624~2690MHz (EFHG) using local frequency without interfering into in-band.

To discriminate Tx / Rx circuit, GRS-2624D-SPR is implemented Bias, including LNA and HPA to functionate switching operation. In the LNA, SPDT switch is implemented not only to improve Tx/Rx separation, but to protect Rx circuits, when antenna is open.

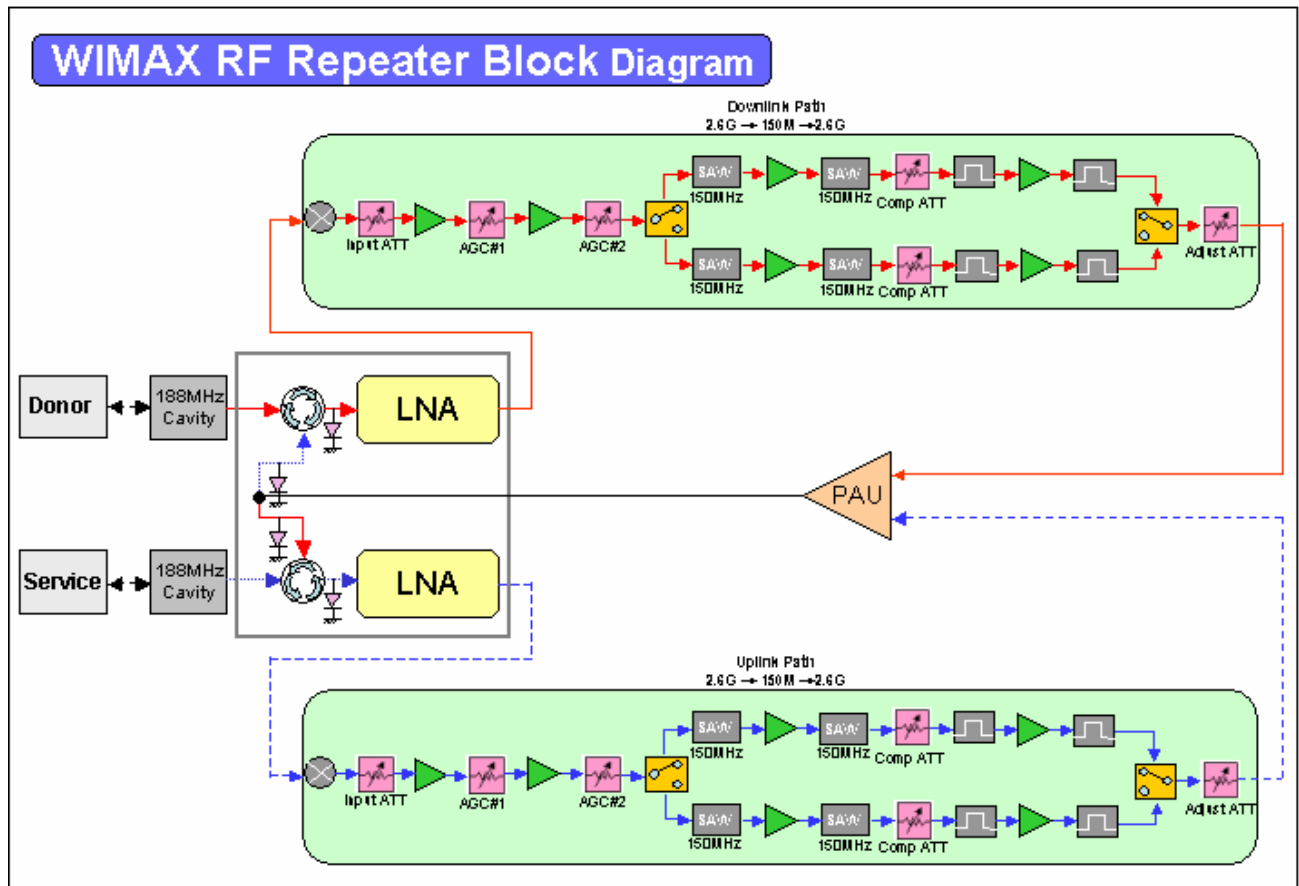

<Pic.4> WIMAX 24dBm RF Repeater Downlink Block Diagram

2.2.3 Uplink Path

GRS-2624D-SPR is basically designed to select 33MHz operational bandwidth from entire BRS bandwidth (188MHz). Repeater would smartly select actual Sprint operational bandwidth such as 2502~2568MHz (ABCD), 2624~2690MHz (EFHG) using local frequency without interfering into in-band.

To discriminate Tx / Rx circuit, GRS-2624D-SPR is implemented Bias, including LNA and HPA to functionate Switching operation. In the LNA, SPDT switch is implemented not only to improve Tx/Rx separation, but to protect Rx circuits, when antenna is open.

GRS-2624D-SPR Downlink, Uplink Converter Module's Gain is 20dB for both paths

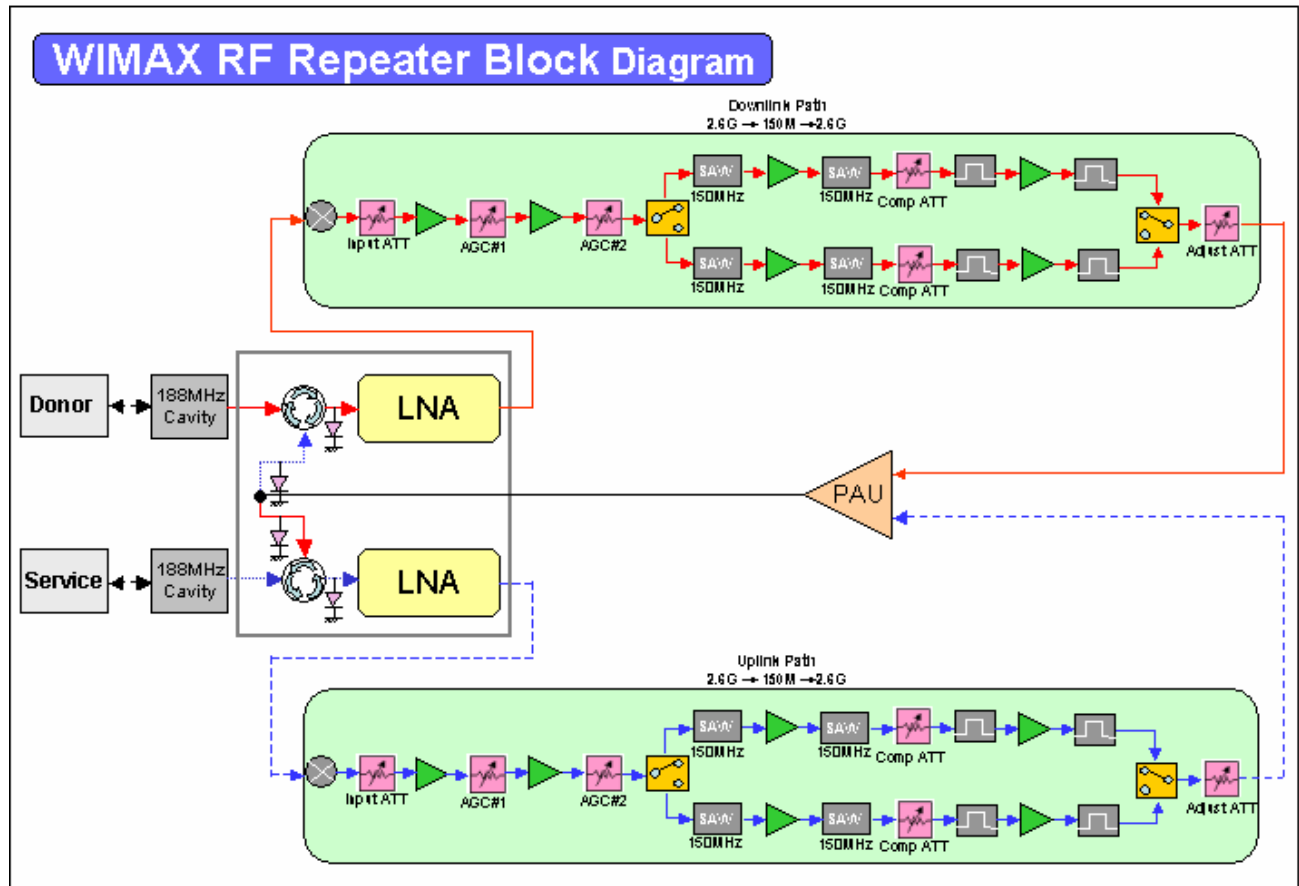

<Pic.5> WIMAX 24dBm RF Repeater Uplink Block Diagram

3. SPECIFICATIONS

3.1 System Specifications

Parameter		Specifications	Comment
Frequency Range		2502MHz ~ 2690MHz	
Band Select (33MHz)	A+B	2502MHz ~ 2535MHz	
	B+C	2518.5MHz ~ 2551.5MHz	
	C+D	2535MHz ~ 2568MHz	
	E+F	2624MHz ~ 2657MHz	
	F+H	2640.5MHz ~ 2673.5MHz	
	H+G	2657MHz ~ 2690MHz	
Max Gain		80dB \pm 1.5dB	
Flatness		\leq 3dB (P-P) / Channel	
VSWR		Max 1.5 : 1	
System Delay		Max 5us	
Input Power Range	D/L	- 50dBm ~ -20dBm	
	U/L	- 50dBm ~ -20dBm	
ALC Range	D/L	0 ~ 30dB	Accuracy \pm 2.0dB
ALC Range	U/L	0 ~ 30dB	Accuracy \pm 2.0dB
Roll offs		30dBc @ \pm 1MHz 80dBc @ \pm 3.5MHz	
EVM		\leq 5% (against the source)	
Out of Band Emission	\pm 1.55MHz	-13dBm@100kHz	
	\pm 3.5MHz	-13dBm@1MHz	
	\pm 5MHz	-37dBm@1MHz	
	\pm 8MHz	-37dBm@1MHz	
Noise Figure		5dB @ Max Gain 12dB @ Min Gain	
Frequency Stability		\leq 0.02ppm	

Switching Adjustment Range	TTG : 0 ~ -105.7us RTG : 0 ~ -60us Guard Offset : 0 ~ 30us	TTG: 105.71us RTG: 60us
Switching Timing Adjustment Accuracy	≤ ±1us / 1us	TTG , RTG , Guard Offset

Parameter		Specifications	Comment
Input Power Accuracy	D/L	± 2dB	
	U/L		
Output Power Accuracy	D/L	± 2dB	
	U/L		
RSSI Alarm		≤ -55dBm	Only DL
Over Power Alarm	D/L	27dBm/ Total	
	U/L	27dBm/ Total	
VSWR Alarm	D/L	When Output Port is open	
	U/L		

3.2 Electrical and Environment Specifications

Parameter	Specifications	Comment
Connector Type	N-type Female 2 port	N-Type : DL 1 port, UL 1 port
Size	350mm X 400mm X 215mm	
Weight	Max 50 lbs	
Power Consumption	90W	
Power Source	110-125VAC, 60Hz 208-240VAC single phase	4 hour Back up Battery (option)
Remote Operating Temperature	-10℃ ~ 50℃	
Remote Operating Humidity	5%~100%	

4. SET UP

4.1. Equipment needed for WIMAX RF Repeater Setup

Parameter	Item	Quantity	Remark
Major Component	Repeater GRS-2624D-SPR	1 EA	Provided by GST
Additional components	Mounting Bracket	1 EA	Provided by GST
	Installation Guide Book V. 1.0	1 EA	
	CD which contains User Manual and Installation Guide V.1.0	1 EA	
	Ethernet Cable 2M	1 EA	
	Power Cord 3M	1 EA	
	Ground Cable 3M	1 EA	
	Ground Sems Screw	4 EA	
	Bracket Sems Screw	4 EA	
	Lag Screw	4 EA	
Anchor Bolt Set	4 EA		
Antenna	Donor ANT	1 EA	Not Included
	Server ANT	1 EA	
RF Cable	Antenna connection Cable	TBD	Not Included
Testing and Measuring Equipment	Spectrum Analyzer	1 EA	Not Included

4.1.1 Notice

- 1) System Power check: Major electricity is AC110V, therefore please input electricity after power verification.
- 2) Input condition optimization: DL, UL input condition of WiMAX 24dBm is -50 ~ -20dBm
- 3) This equipment is basically wall mountable installation.

4.1.2 System set up

- 1) This equipment is basically wall mountable.
- 2) Installer will have to connect the power supply (after input power verification) and RF cable to the Repeater and then it will be ready to use.
- 3) For grounding, there is a grounding terminal in main power supply which will be plugged into power outlet. There is also a separate grounding terminal on the repeater which should be connected to the on-site grounding terminal to ensure proper grounding.
- 4) Mounting of repeater should be done by at least two technicians to ensure a safe and proper install.

4.1.3 Open for service

- 1) Check points before open
 - a. Verification of system installation status
Electricity, In/out antenna, coaxial cable connection, equipment mounts status.
 - b. Verification of system accessories
User should check whole necessary accessories.
 - c. Check receipt signal level
User should check whether receipt environmental condition is in accordance with system specification, so that system operation will be optimized.

4.2 Troubleshooting

4.2.1 Necessary Testing and measuring equipment

- a. Signal Generator: 3GHz
- b. Spectrum Analyzer: 3GHz
- c. Multi-Meter

4.2.2 Notice

- a. Troubleshooting should be performed by a trained technician.
- b. Parts that seem to be not used should not be disassembled.
- c. While troubleshooting, technician should use attenuator to check RF Signal output.

4.2.3 Troubleshooting Guide

Item	Check Point	Trouble shooting						
Note before system operation	* System Input power range	<table border="1" data-bbox="734 407 1489 573"> <thead> <tr> <th colspan="2" data-bbox="734 407 1489 464">Input Level</th> </tr> </thead> <tbody> <tr> <td data-bbox="734 464 1016 516">Down Link</td> <td data-bbox="1016 464 1489 516">-50dBm/Total ~ -20dBm/Total</td> </tr> <tr> <td data-bbox="734 516 1016 573">Up Link</td> <td data-bbox="1016 516 1489 573">-50dBm/Total ~ -20dBm/Total</td> </tr> </tbody> </table>	Input Level		Down Link	-50dBm/Total ~ -20dBm/Total	Up Link	-50dBm/Total ~ -20dBm/Total
Input Level								
Down Link	-50dBm/Total ~ -20dBm/Total							
Up Link	-50dBm/Total ~ -20dBm/Total							
Same as above	* System Gain	<table border="1" data-bbox="734 737 1489 903"> <thead> <tr> <th colspan="2" data-bbox="734 737 1489 793">Gain</th> </tr> </thead> <tbody> <tr> <td data-bbox="734 793 1016 846">Down Link</td> <td data-bbox="1016 793 1489 846">50 ~ 80dB</td> </tr> <tr> <td data-bbox="734 846 1016 903">Up Link</td> <td data-bbox="1016 846 1489 903">50 ~ 80dB</td> </tr> </tbody> </table>	Gain		Down Link	50 ~ 80dB	Up Link	50 ~ 80dB
Gain								
Down Link	50 ~ 80dB							
Up Link	50 ~ 80dB							
Same as above	* Output power at edge port side	<table border="1" data-bbox="734 1066 1489 1232"> <thead> <tr> <th colspan="2" data-bbox="734 1066 1489 1123">Output power</th> </tr> </thead> <tbody> <tr> <td data-bbox="734 1123 1135 1176">Down Link</td> <td data-bbox="1135 1123 1489 1176">30dBm/Total</td> </tr> <tr> <td data-bbox="734 1176 1135 1232">Up Link</td> <td data-bbox="1135 1176 1489 1232">30dBm/Total</td> </tr> </tbody> </table>	Output power		Down Link	30dBm/Total	Up Link	30dBm/Total
Output power								
Down Link	30dBm/Total							
Up Link	30dBm/Total							
Check in Advance	* Check points before open for service	<ul style="list-style-type: none"> * Please check quantity of all accessories with specification before you set up. * Fit cable length in accordance with field condition. * Set up Donor antenna to secure Isolation (More than 87dBc) 						

<p>Check after open</p>	<p>* Check points after open for service</p>	<p>* Check following status</p> <ul style="list-style-type: none"> - Fixable level of antenna support pole - Connection status between antenna and RF cable - RF Cable construction and fixed status - Verify that the Repeater is securely mounted - Electricity construction and proper AC power status - Plug status and electricity voltage status - Wall socket and voltage status - Grounding status of electrical circuit - Direction of Donor antenna (PN Offset and neighborhood BTS to be considered.) - Coaxial cable construction status - Connector combiner connection status - Cable connection status against leakage of water
-------------------------	--	--