

SpeedCell Repeater

INSTALLATION GUIDE

Ver. 1.0

SpeedCell Repeater

Installation Guide Ver. 1.0

Contents of Box

Contents	Picture	Quantity	Contents	Picture	Quantity
SpeedCell Repeater System PSU Unit 4.3"(W) x 16.9"(H) x 10.7"(D) , 15 lbs DFM Unit 2.8"(W) x 16.9"(H) x 10.7"(D), 9.9 lbs 1900 AMP Unit 3.9"(W) x 16.9"(H) x 10.7"(D), 15.2 lbs		1EA	Ground Cable 6.6ft (2m)		1EA
			Power Cord 5.9ft (1.8m)		1EA
			Ethernet Cable 6.6ft (2m)		1EA
Mounting Bracket 23.2"(W) x 18.5"(H) x 2.75"(D), 23.5 lbs		1EA	Lag Screw 1/2" x 2"		4EA
CD which contains - User Manual - Installation Guide		1EA	Ground Sems Screw M4 x 8mm		4EA
RF Cable Set Front RF Cable 2EA, Top RF Cable 4EA, Reference Cable 3EA		1EA	Mounting Sems Screw M6 x 10mm		8EA

This publication provides instruction for installing the SpeedCell repeaters.

The images for the User Interface in this publication may vary from the repeater's depending on its S/W Version.

Copyright

© 2011, GS Teletech, Inc.
All Rights Reserved
Printed in Republic of Korea

Revision History

Date	Version	Changes
03/2011	version 1.0	

Certification

UL/FCC: This equipment complies with UL and FCC

Warnings and Hazards

WARNING! ELECTRIC SHOCK

Opening the BDA (bi-directional amplifier) could result in electric shock and may cause severe injury.

WARNING! EXPOSURE TO RF

Working with the repeater while in operation, may expose the technician to RF electromagnetic fields that exceed FCC rules for human exposure. Visit the FCC website at <http://www.fcc.gov/oet/rfsafety> to learn more about the effects of exposure to RF electromagnetic fields.

WARNING! DAMAGE TO EQUIPMENT

Operating the BDA with antennas in very close proximity facing each other could lead to severe damage to the repeater.

RF EXPOSURE & ANTENNA PLACEMENT





Actual separation distance is determined upon gain of antenna used.

Please maintain a minimum safe distance of at least 8inch while operating near the donor and the server antennas. Also, the donor antenna needs to be mounted outdoors on a permanent structure.

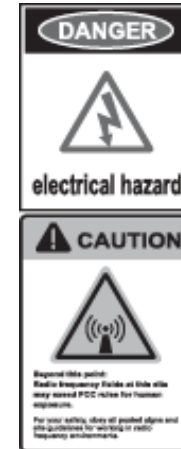
WARRANTY

Opening or tampering the BDA will void all warranties.



-  **CAUTION: REPEATER SHOULD BE INSTALLED AS CLOSE AS POSSIBLE TO POWER SOURCE.**
-  **CAUTION: THIS REPEATER IS FOR INDOOR USE ONLY AND SHOULD BE LOCATED INSIDE OF BUILDING.**
-  **CAUTION: RISK OF EXPLOSION IF BATTERY ON CONTROLLER BOARD IS REPLACED WITH AN INCORRECT TYPE.**
-  **CAUTION: DISPOSE OF USED BATTERIES ACCORDING TO THE INSTRUCTIONS**

Mounting Repeater

Wood-Framed Wall

- It is recommended to first attach a sheet of plywood to the wall. The sheet of plywood should be anchored to the studs in the wall.
- Using a pencil, mark the location for each of the mounting bracket's four mounting holes on the plywood.
- Place the mounting bracket over the four lag screws heads.
- Thread a lag screw at the positions marked in step 2.

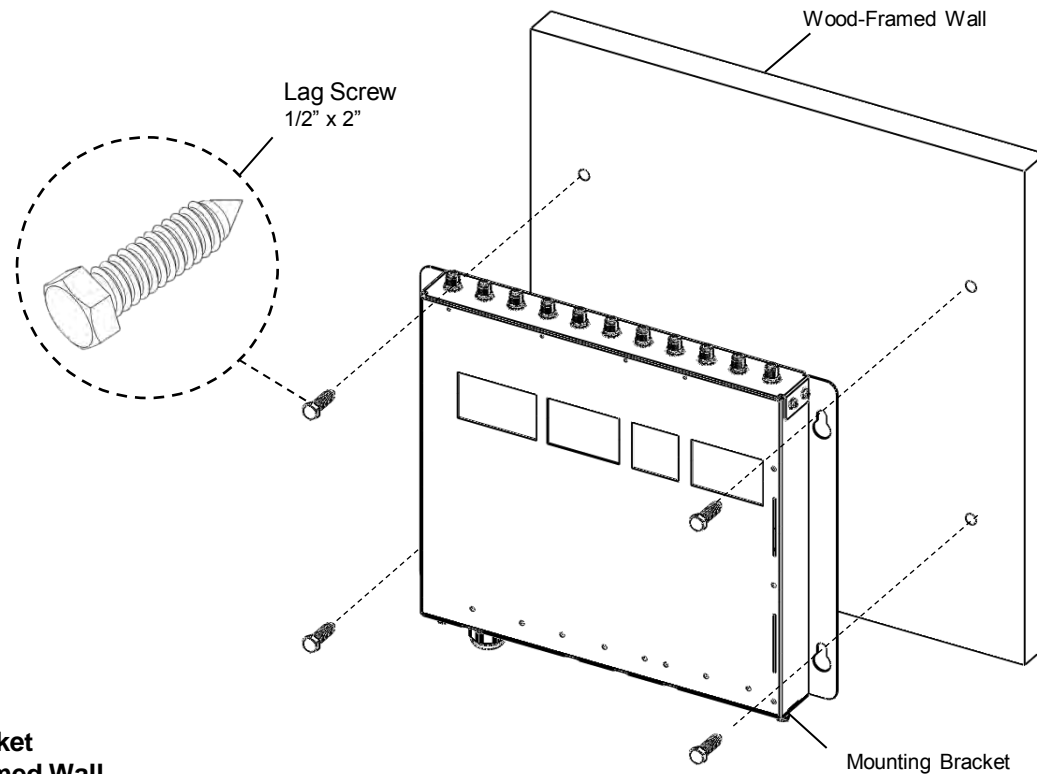

**<Picture 1> Mounting the Bracket
on a Wood-Framed Wall.**

Hang and Grounding

- Hang the PSU unit to the mounting bracket.
- Locate the two Mounting Sems Screws (M6 x10mm) underneath the PSU unit. Tighten bolts until secure.

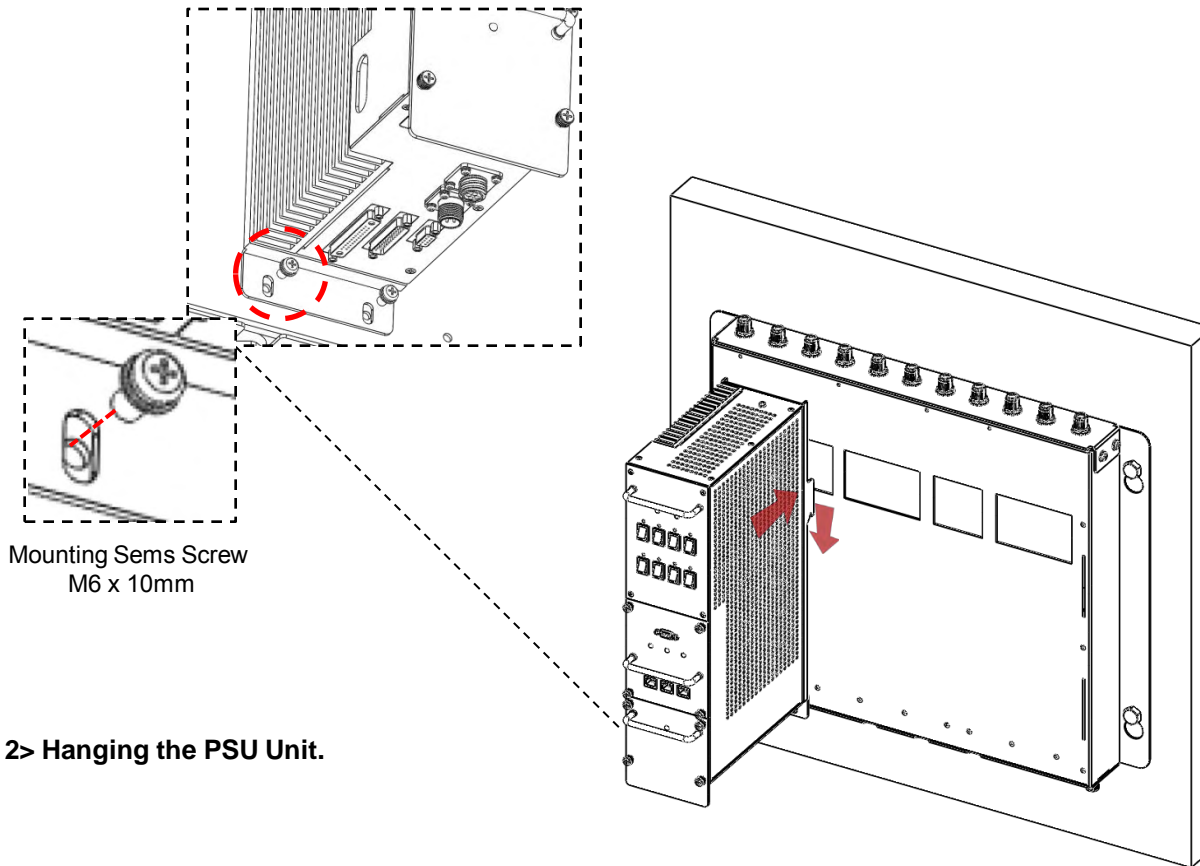

<Picture 2> Hanging the PSU Unit.

Hang and Grounding

- Hang the rest of the units in the following order: 1900 AMP, DFM, 800/900 AMP.
- Locate the two Mounting Sems Screws (M6 x10mm) underneath each unit. Tighten bolts until secure.

CAUTION

 Units must be hung in the following order only: PSU -> 1900 AMP -> DFM -> 800/900 AMP.

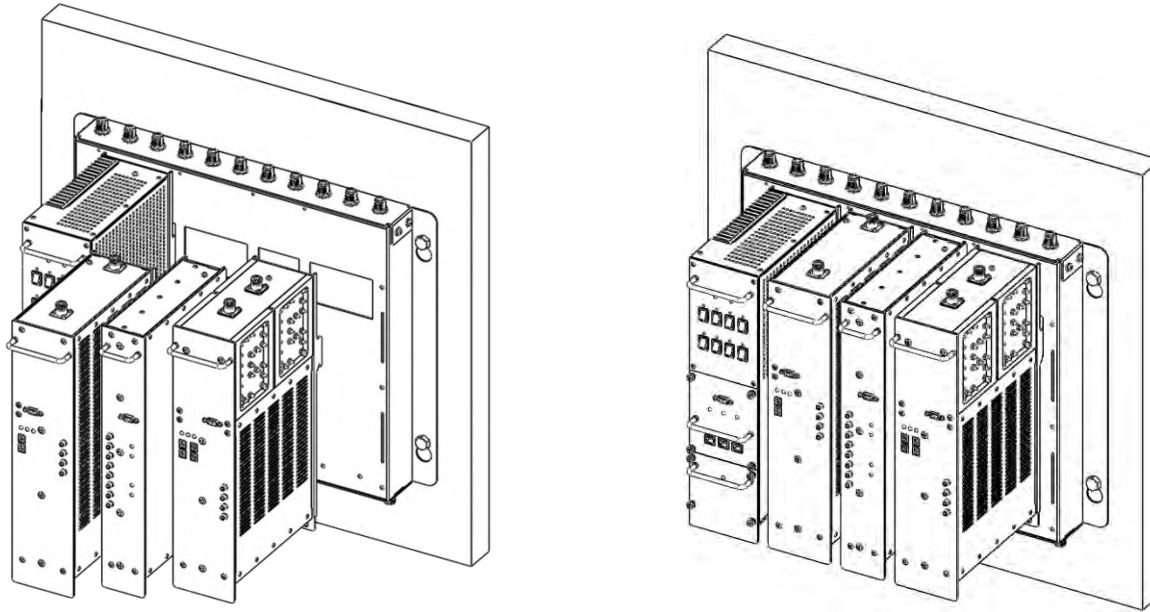

<Picture 3> Hanging the Rest of Units.

Hang and Grounding

- Connect ground cables of each unit to the bracket using Ground Sems Screws (M4 x 8mm) as displayed at the picture below.

CAUTION

 *Ground cables must be properly grounded to provide both EMI and voltage surge protection for the repeater.*



Ground Cable

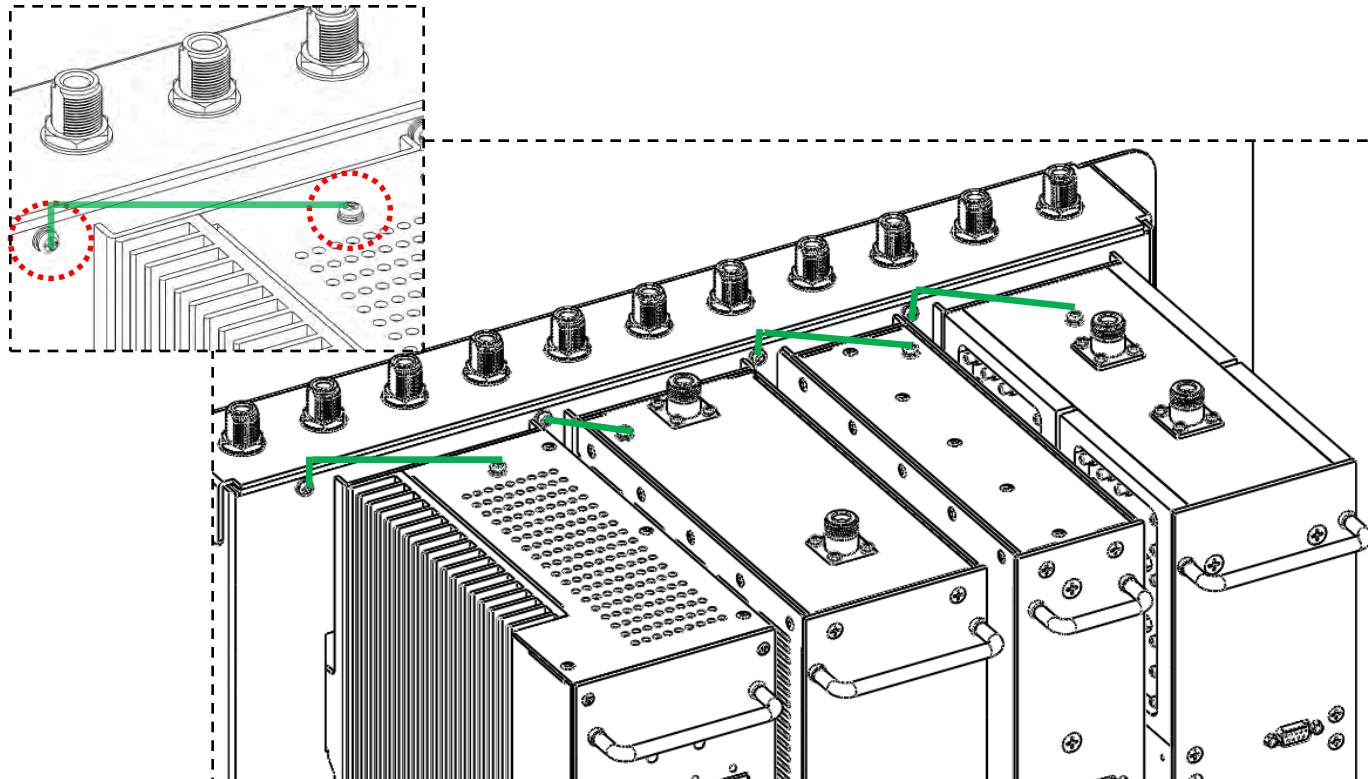

<Picture 3> Grounding of the PSU, 1900 AMP, DFM, 800/900 AMP Units.

Hang and Grounding

- Locate the ground lug on the underside (or side) of the bracket.
- Crimp the ground cable to the ground lug.
- Route the free end of the ground cable to an approved (per local code or practice) ground source.

CAUTION

 *Ground cable must be properly grounded to provide both EMI and voltage surge protection for the repeater.*

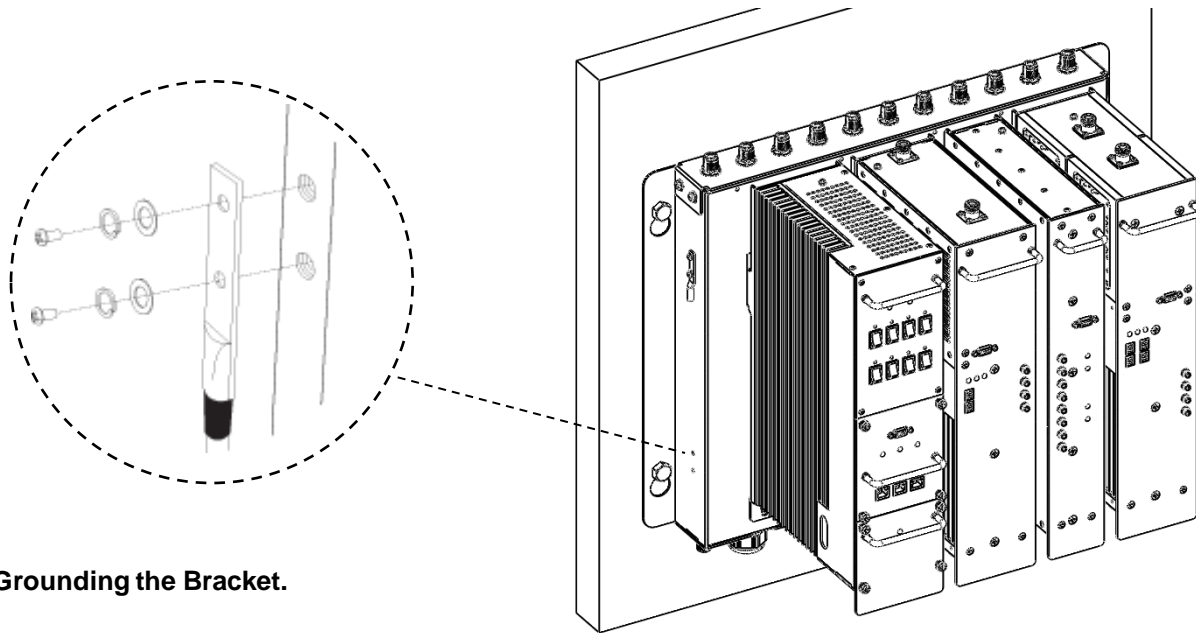

<Picture 4> Grounding the Bracket.

Position Antenna

- After installing 800/900MHz and 1900MHz antennas the installer should make line of site.
- Customer specifications should be followed for positioning the antennas properly.

Warning: In order to avoid the possibility of exceeding the FCC radio frequency exposure limits, human proximity to the antenna should not be less than 20cm during normal operation. The gain of the antenna is 12 dBi.



<Picture 5> An installer is directing Donor Antenna to nearby BTS to receive strong input signal.

RF Cable Connections: Top of The Repeater

- Connect the 800/900 and 1900 Donor Antennas to their corresponding ports.
- Plug in four N(M) to N(M) type RF cables as demonstrated in the picture below.

CAUTION

Do not connect or disconnect cable from ANT port when power is ON.

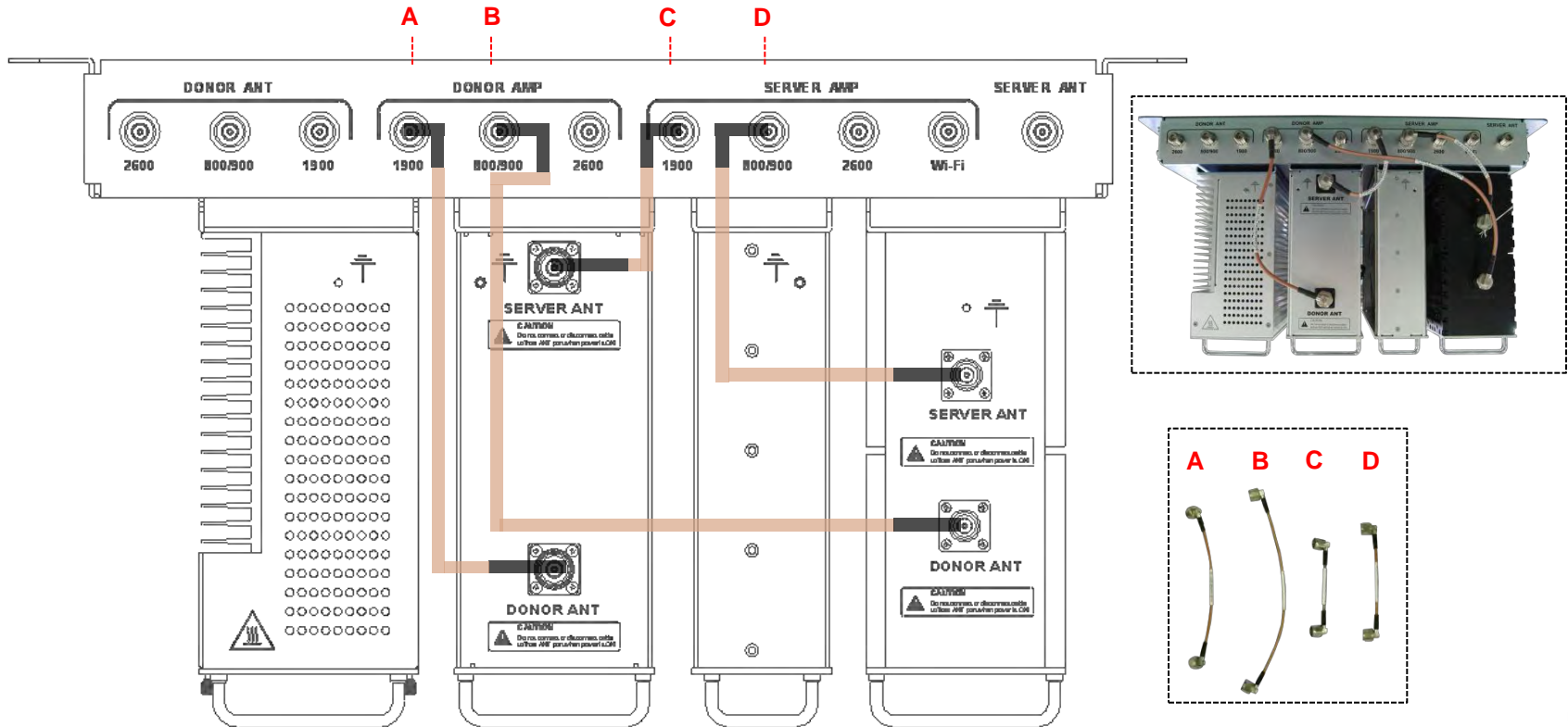

<Picture 6> Top View of the Repeater.

RF Cable Connections: Front Side

- Take out two SMA (M) to SMA (M) type RF cables.
- Please, pay attention to cable's corresponding number and its color while connecting.
- Connect 1900 AMP and DFM via Band 1, and 800/900 AMP and DFM via Band 2.

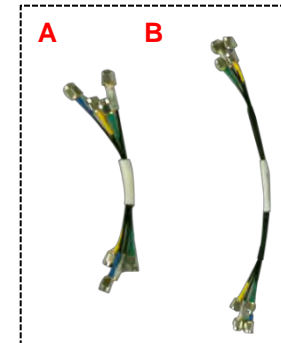
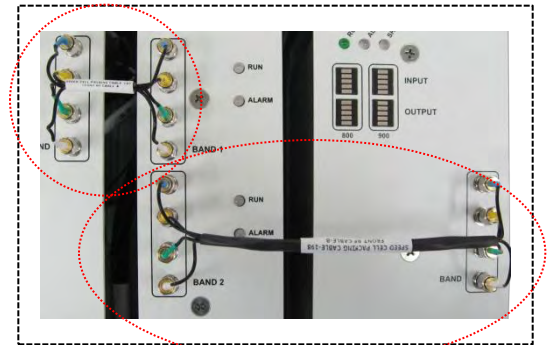
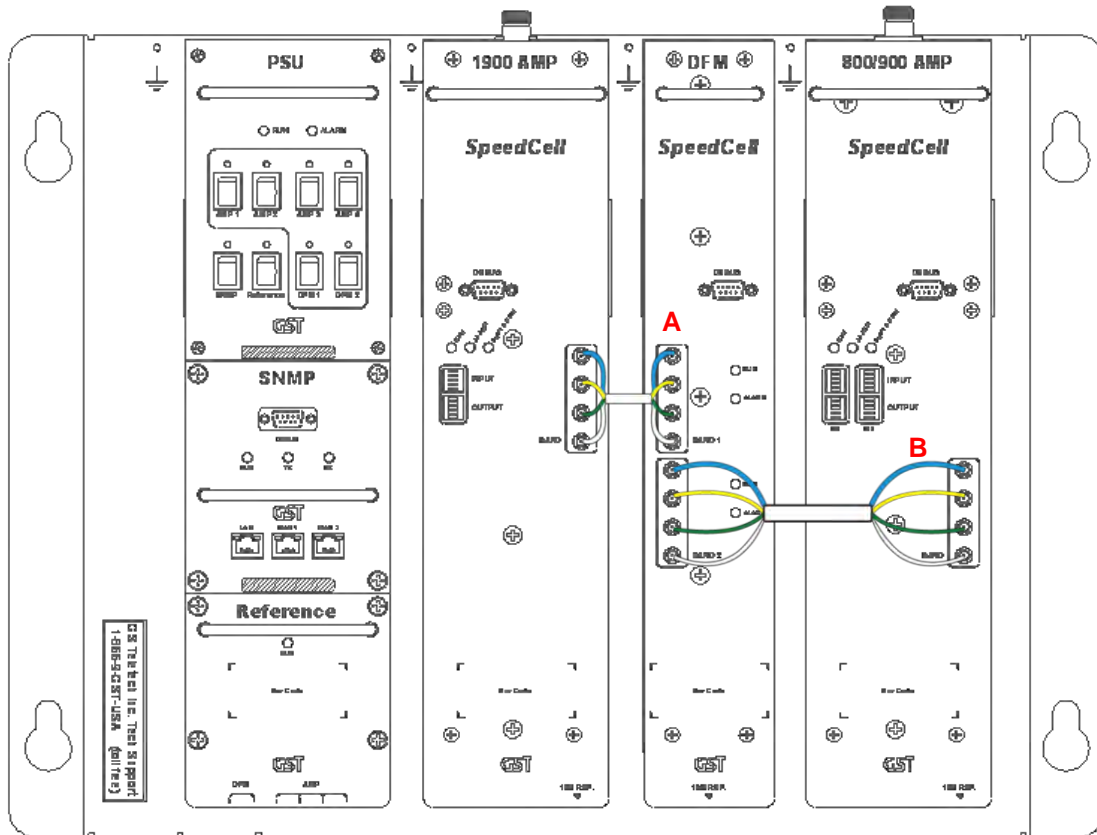

<Picture 7> Front View of the Repeater.

RF Cable Connections: Bottom of The Repeater

- Take out three SMA (M) to SMA (M) type RF cables.
- While connecting the PSU and the DFM units underneath, use referenced cable and pay attention to the labels. Plug them into their corresponding outlets.
- User may choose either of the two SMA ports on the bottom of the PSU to connect to the DFM.
- User may choose any two of the four SMA ports on the bottom of the PSU to connect to amplifiers.

CAUTION

Please, pay attention while connecting PSU and DFM, PSU and 800/900 AMP, 1900 AMP units. The repeater will not work if connection is inappropriate.

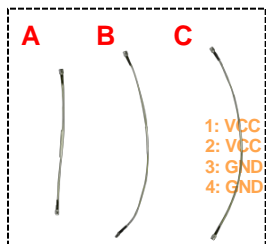
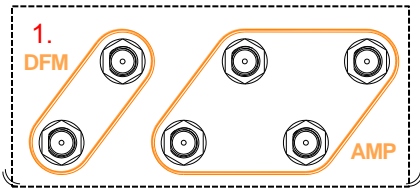
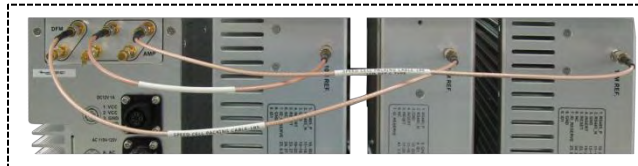

A: AC
B: AC
C: F.G

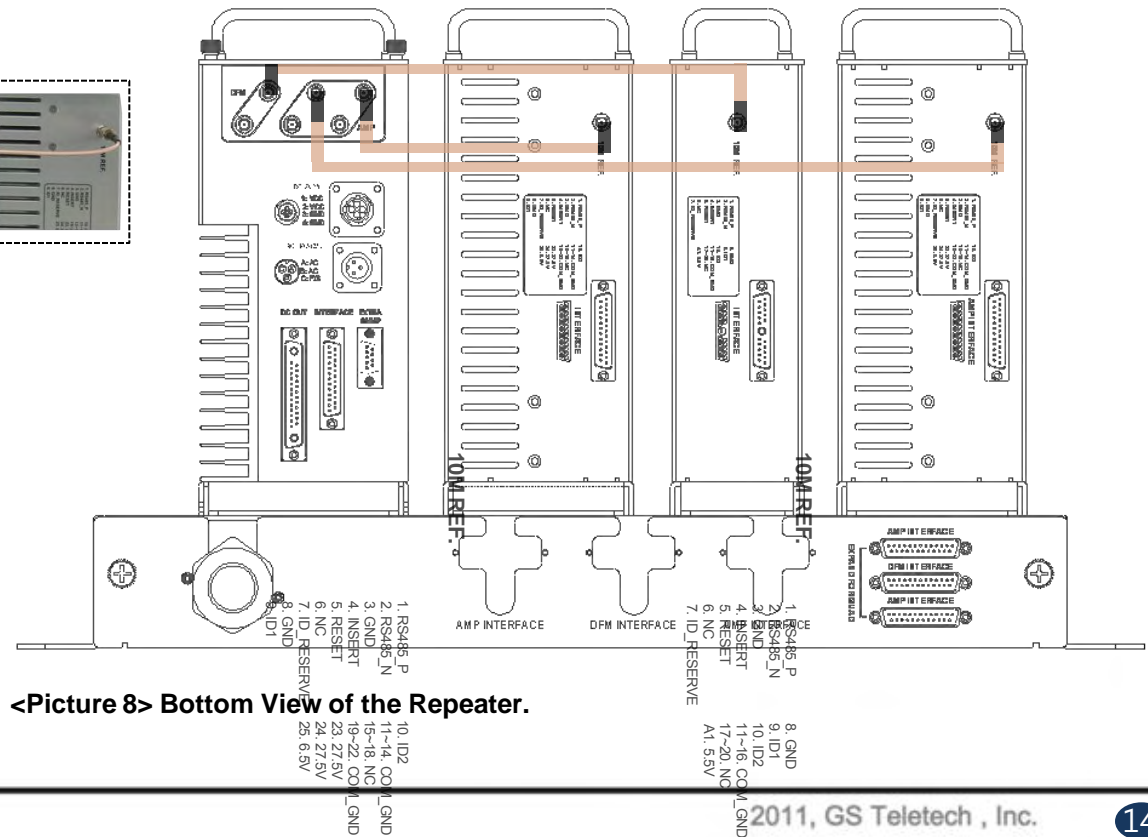

<Picture 8> Bottom View of the Repeater.

Power Cord Connections

- Plug in the cables to PSU, DFM, 1900AMP, DFM and 800/900 AMP as displayed at the picture below.

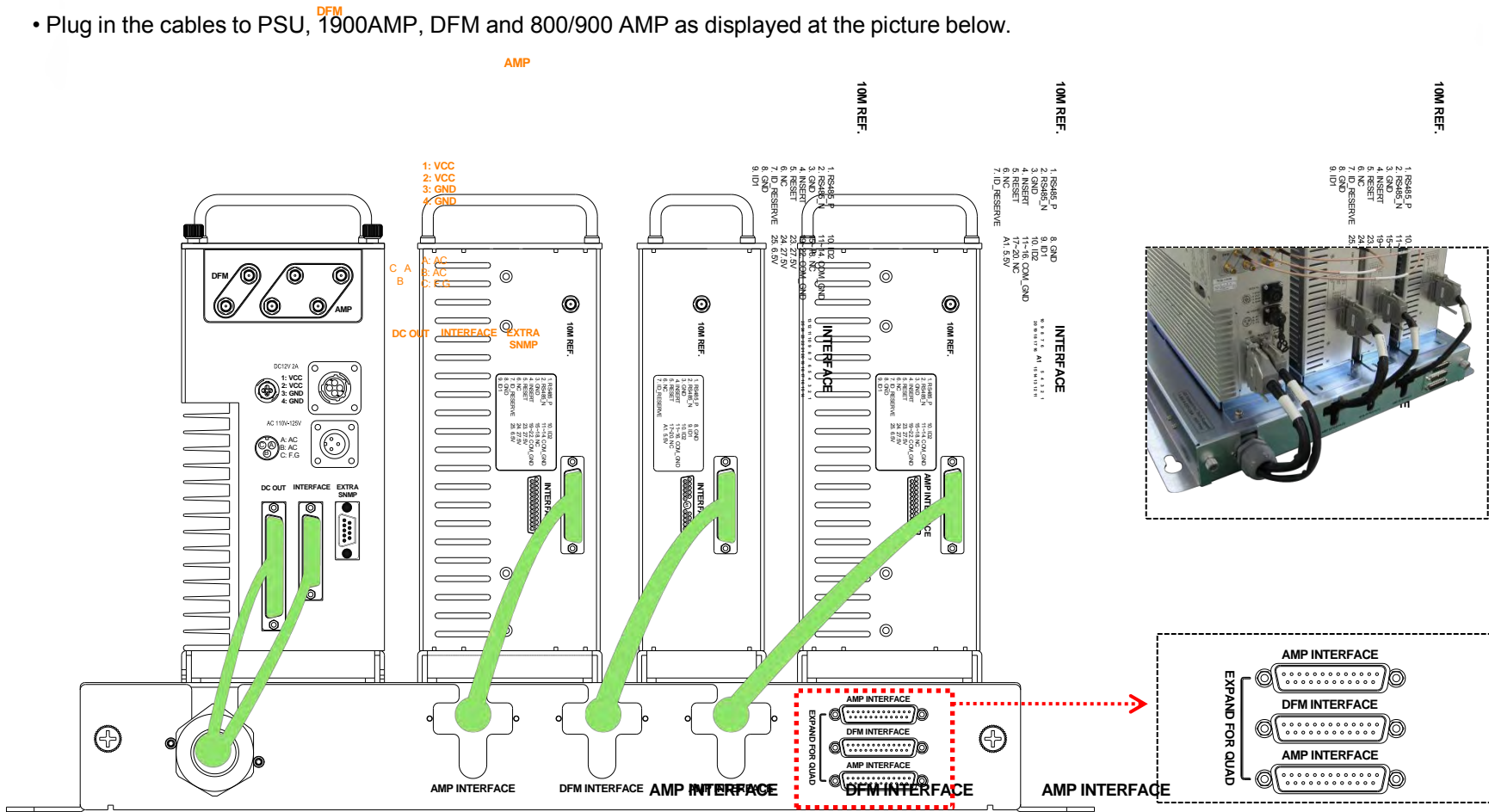

<Picture 9> Bottom View of the Repeater.

These ports are used for an added 2600 MHz amplifier while extension of the repeater.

Connecting Power Cable and LED Light Verification

- Connect Power Cable

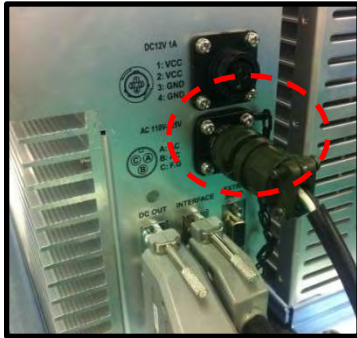

<Picture 10> AC Power Port Connection.

- Turn the switch "ON" on the left side of PSU.

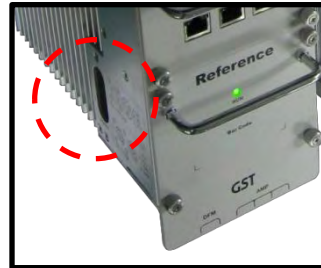

<Picture 11> ON/OFF Switch of SpeedCell Repeater.

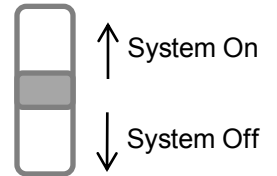

- Turn the switch "ON" on the front side of PSU as displayed at the picture 12.

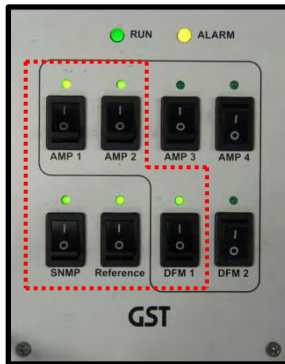

<Picture 12> Verification of LED Lights.

LED Indicators

- The LED's on the repeater will light up and should change to green as displayed at the picture below. Tx and Rx LEDs will be blinking.

RUN LED : Green light ON.

ALARM LED : Green light is normal status, Red light is alarm status.

SHUT DOWN LED : Green light is normal status, Red light is shutdown status.

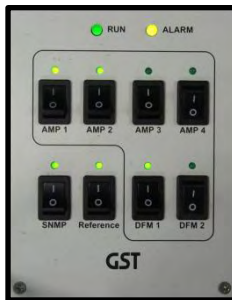

PSU

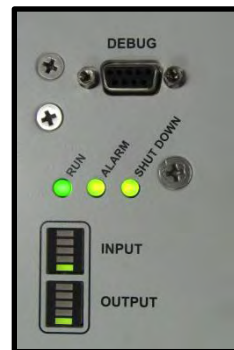

1900 AMP

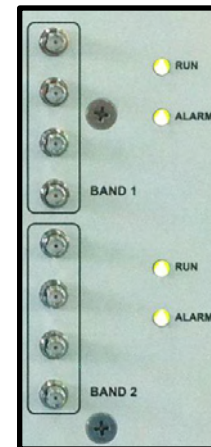

DFM

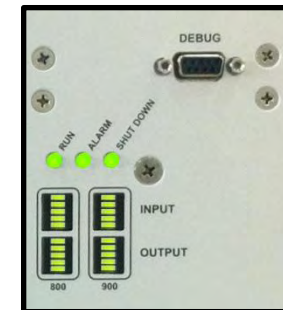

800/900 AMP

Input Power Signal

- Please note the number of LED bars for input indicates signal strength level.

The tables below indicate the levels.

Number of LED bars on the front side of Repeater will show input signal level:

Less than ~ -86dBm	LED 1bar
-85dBm~-79dBm	LED 2 bars
-78dBm~-72dBm	LED 3 bars
-71dBm~-65dBm	LED 4 bars
More than -64dBm	LED 5 bars

<Table 1> LED Bars Indication.

Output Power Signal

- Please note the number of LED bars for output indicates signal strength level.

Number of LED bars on the front side of Repeater will show output signal level:

Less than ~ +5dBm	LED 1bar
+6dBm~+10dBm	LED 2 bars
+11dBm~+15dBm	LED 3 bars
+16dBm~+20dBm	LED 4 bars
More than +21dBm	LED 5 bars

<Table 2> LED Bars Indication.

Web UI

- LAN port is used for connection of laptop and repeater.
- WAN 1 port is used for connection of repeater and wireless modem for remote access.
- WAN 2 port is a redundancy port for remote access.

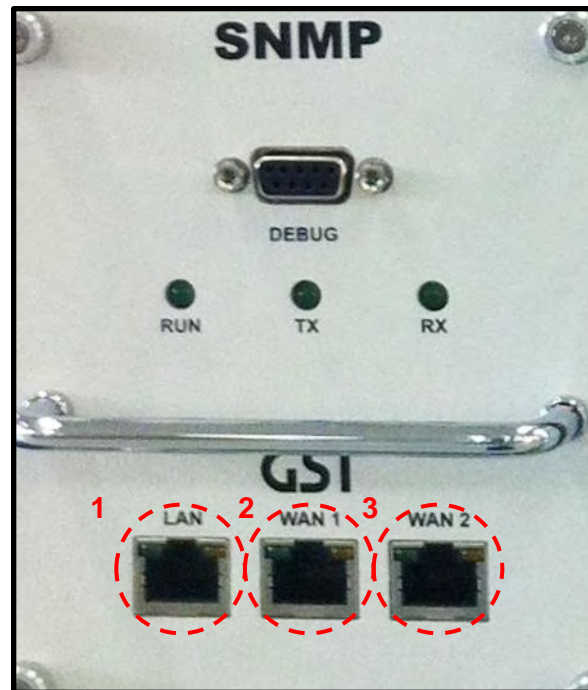

<Picture 12> Ethernet Port.

Configuring Laptop to Connect to Repeater

- Connect Ethernet crossover cable from the LAN port of the repeater to laptop.

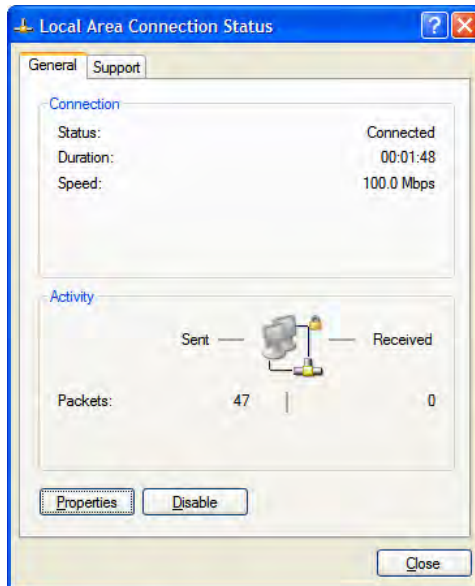

1. Go to Local area connection.

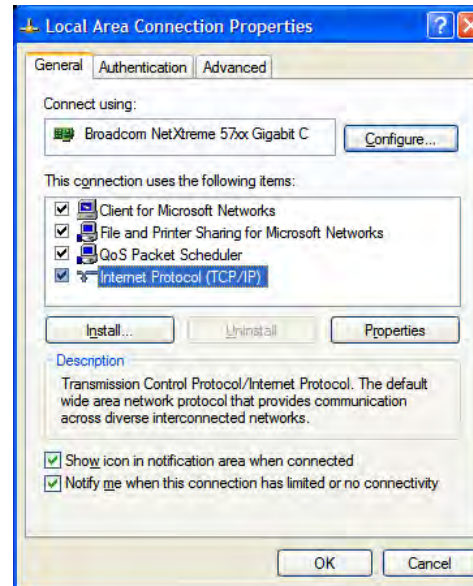

2. Click 'TCP/IP Properties'.

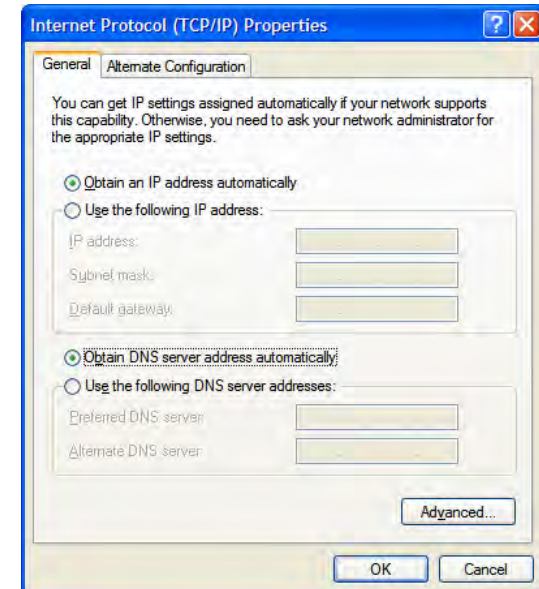

3. Choose 'Obtain DNS server address automatically'.

Login Screen

Enter IP address by 192.168.2.1, you will be redirected to Login. Default User Name is ,admin', and default Password is ,admin'. You may need to change password as described in the User Management section. Engineering Number and Site Name will initially be blank, you can input Engineering Number and Site Name as described in the Communications Configuration section.

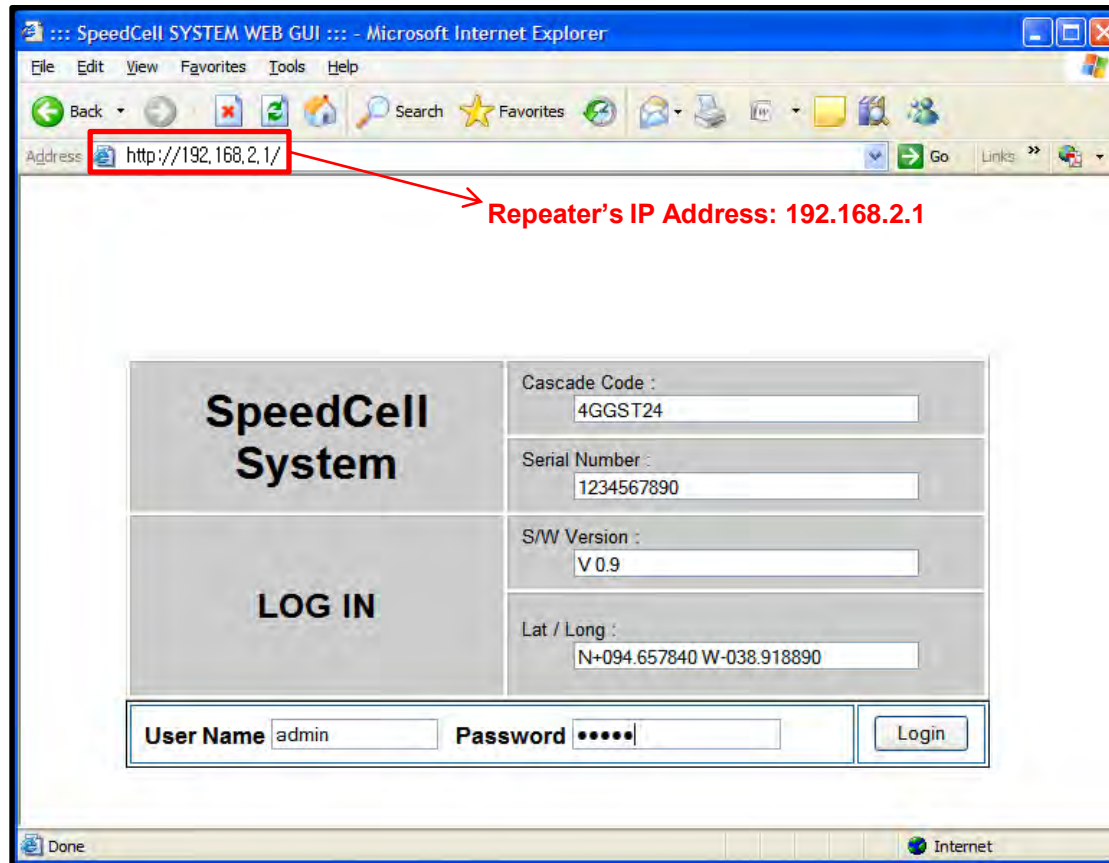

Menu Select

- After you log in, you can see „Menu Select’ page.
- To setup the Repeater, click „Initial Installation’.
- To go to menu list, click „Menu Page’.

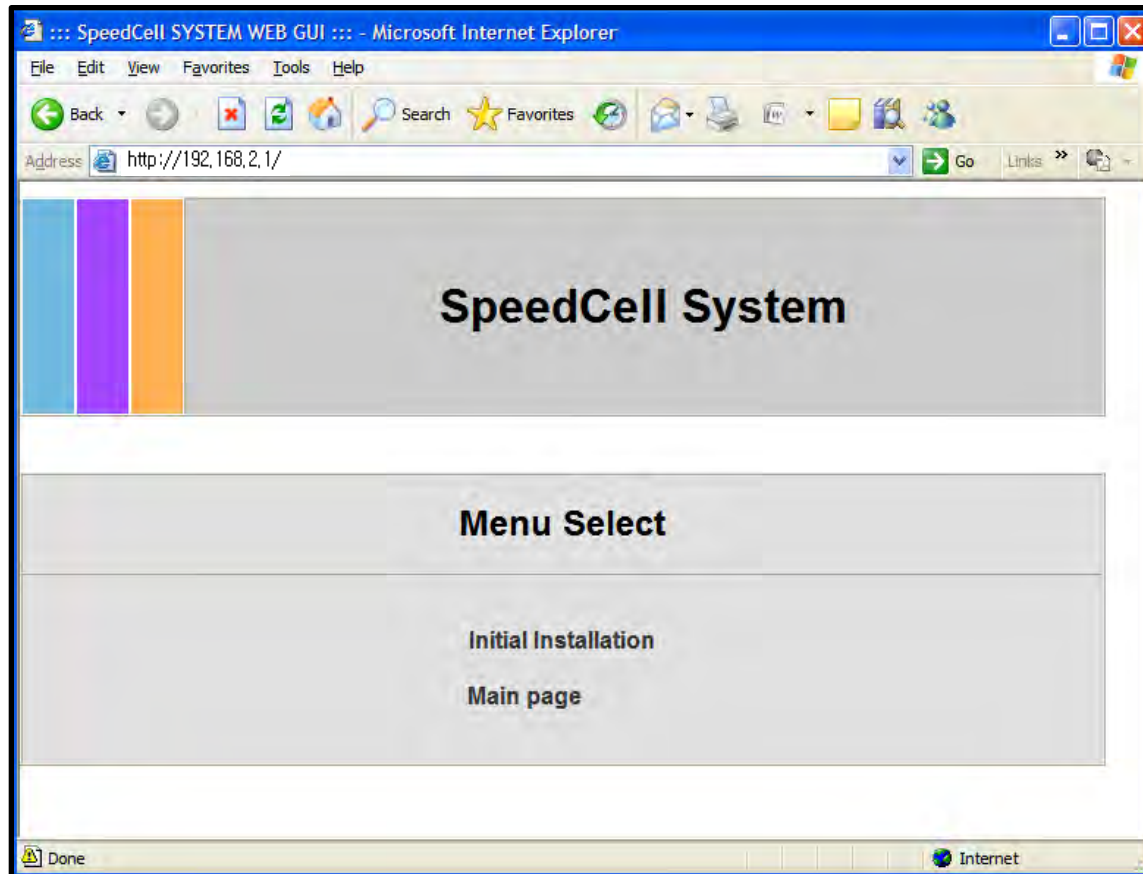

Setup Wizard

- After you clicking on „Initial Installation’ the following screen will be displayed.
- After typing the Latitude or Longitude numbers, press „Apply’ button.
- User may skip this window if it is unnecessary.

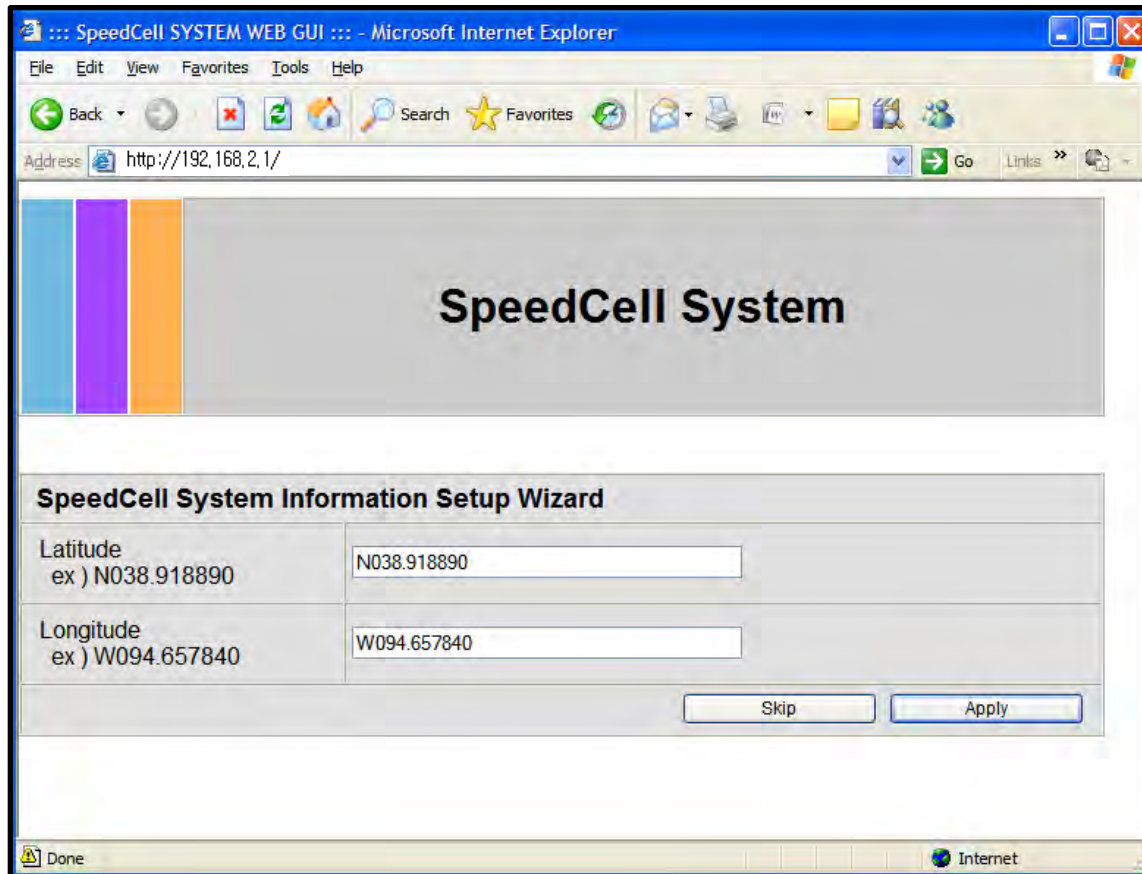

The screenshot shows a Microsoft Internet Explorer browser window displaying the SpeedCell SYSTEM WEB GUI. The address bar shows the URL `http://192.168.2.1/`. The main content area features a header with three vertical bars (blue, purple, orange) and the text "SpeedCell System". Below this is a section titled "SpeedCell System Information Setup Wizard" containing two input fields: "Latitude" with the value "N038.918890" and "Longitude" with the value "W094.657840". At the bottom of the wizard are two buttons: "Skip" and "Apply".

SpeedCell System Information Setup Wizard	
Latitude ex) N038.918890	<input type="text" value="N038.918890"/>
Longitude ex) W094.657840	<input type="text" value="W094.657840"/>
<input type="button" value="Skip"/> <input type="button" value="Apply"/>	

Setup Wizard

- ① Auto Configuration matches amplifier and DFM units automatically.
- ② Manual Configuration matches amplifier and DFM units manually.

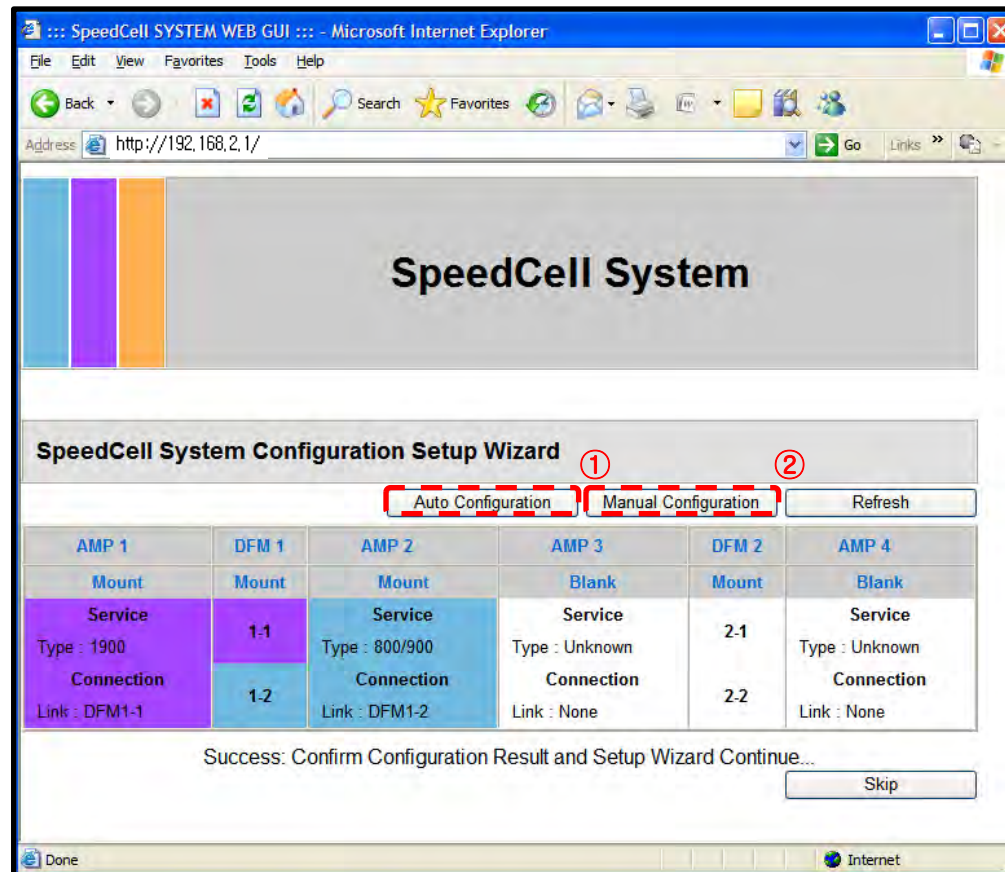

SpeedCell System Configuration Setup Wizard

①
 ②

AMP 1	DFM 1	AMP 2	AMP 3	DFM 2	AMP 4
Mount	Mount	Mount	Blank	Mount	Blank
Service Type : 1900	1-1	Service Type : 800/900	Service Type : Unknown	2-1	Service Type : Unknown
Connection Link : DFM1-1	1-2	Connection Link : DFM1-2	Connection Link : None	2-2	Connection Link : None

Success: Confirm Configuration Result and Setup Wizard Continue...

Setup Wizard

- After clicking Auto Configuration, the screen below will be displayed.
- It will take approximately one minute to finish the process.

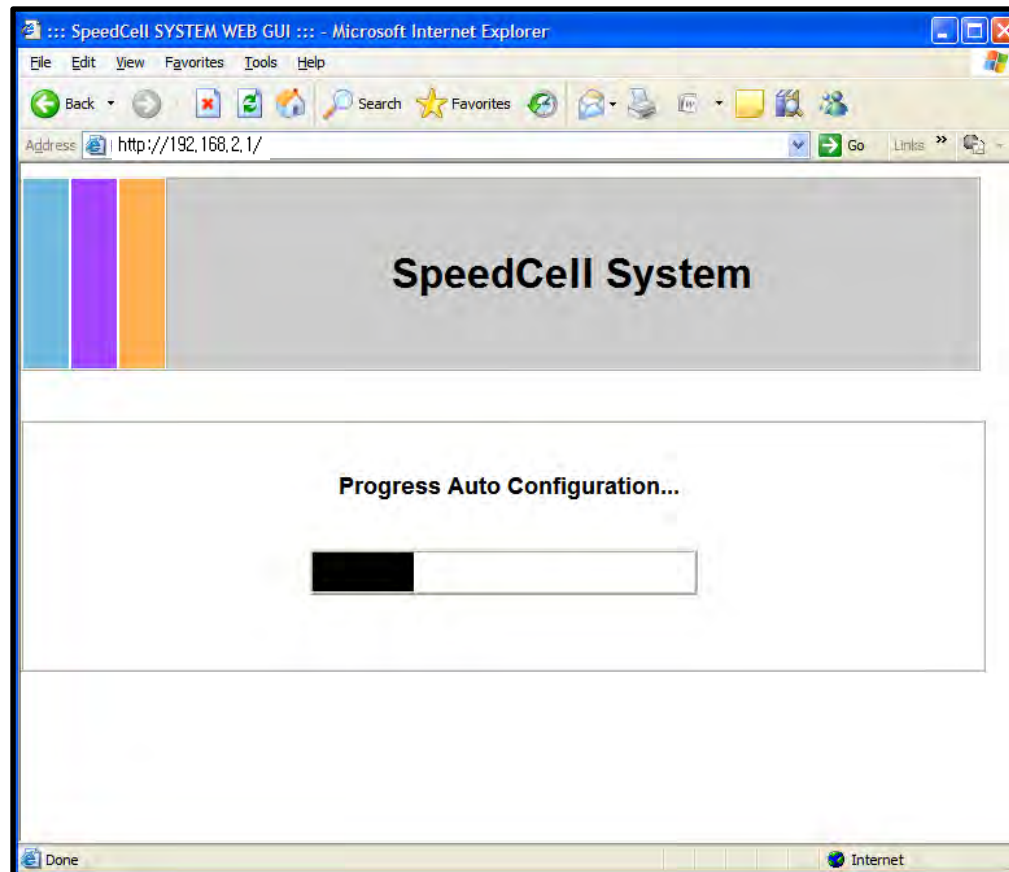

Setup Wizard

- User may also setup repeater manually by clicking on „Manual Configuration’ button.

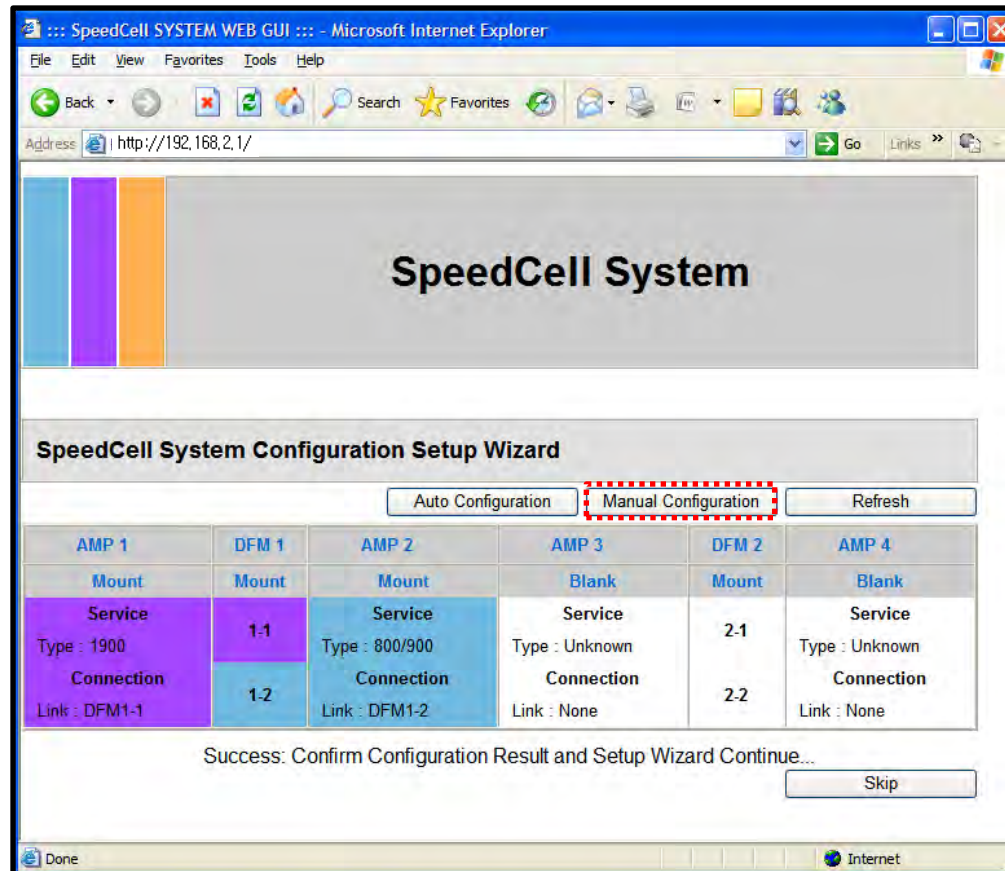

SpeedCell System Configuration Setup Wizard

Auto Configuration **Manual Configuration** Refresh

AMP 1	DFM 1	AMP 2	AMP 3	DFM 2	AMP 4
Mount	Mount	Mount	Blank	Mount	Blank
Service Type : 1900	1-1	Service Type : 800/900	Service Type : Unknown	2-1	Service Type : Unknown
Connection Link : DFM1-1	1-2	Connection Link : DFM1-2	Connection Link : None	2-2	Connection Link : None

Success: Confirm Configuration Result and Setup Wizard Continue...

Skip

Setup Wizard

- Information about connected amplifiers will be displayed automatically. Nevertheless user may change setting values if it is needed.

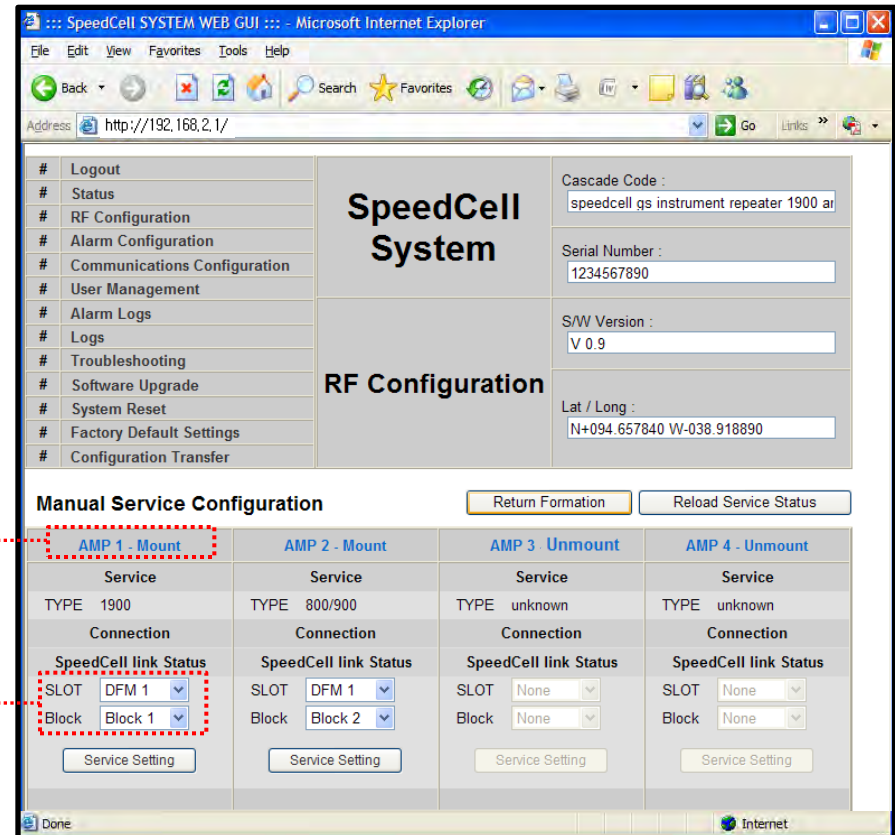

Manual Service Configuration

AMP 1 - Mount	AMP 2 - Mount	AMP 3 - Unmount	AMP 4 - Unmount
Service	Service	Service	Service
TYPE 1900	TYPE 800/900	TYPE unknown	TYPE unknown
Connection	Connection	Connection	Connection
SpeedCell link Status	SpeedCell link Status	SpeedCell link Status	SpeedCell link Status
SLOT DFM 1	SLOT DFM 1	SLOT None	SLOT None
Block Block 1	Block Block 2	Block None	Block None
Service Setting	Service Setting	Service Setting	Service Setting

It means that amplifier is mounted and connected.

'SLOT' shows which DFM is connected to the amplifier. And 'Block' shows which block of DFM unit is connected to amplifier.

Setup Wizard

Manual Setup Wizard for 1900MHz Band (Choosing channels and bands)

- User may choose band according to the specific site circumstances. After checking necessary bands, click „Apply’ button.
- Also User may skip this setting if it is not needed.

User may type maximum 50 digits in Cascade Code.

User may choose delete all bands.

User may choose 15MHz block of A band only.

User may choose 5MHz block of E band only.

User may choose channel within the selected band.

User may choose 5MHz block of G band to provide LTE service.

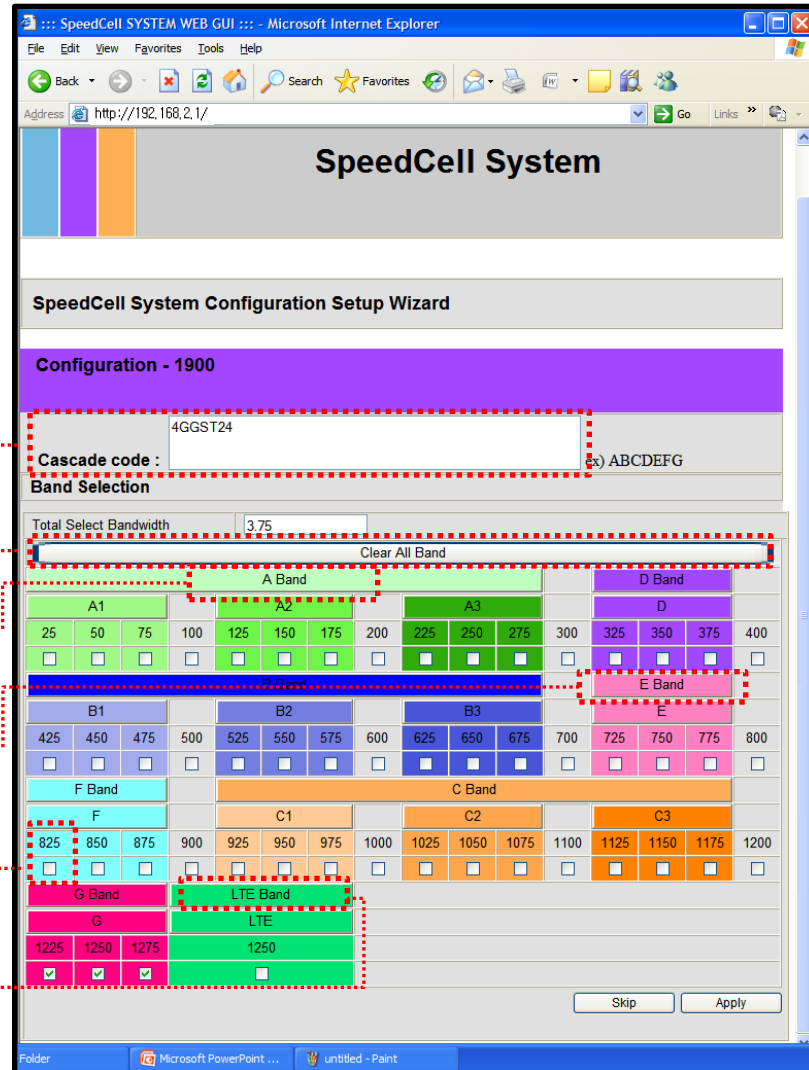

SpeedCell System Configuration Setup Wizard

Configuration - 1900

Cascade code : 4GGST24

Band Selection

Total Select Bandwidth: 3.75

Clear All Band

A1			A2			A3			D						
25	50	75	100	125	150	175	200	225	250	275	300	325	350	375	400
<input type="checkbox"/>	<input type="checkbox"/>	<input type="checkbox"/>	<input type="checkbox"/>	<input type="checkbox"/>	<input type="checkbox"/>	<input type="checkbox"/>	<input type="checkbox"/>	<input type="checkbox"/>	<input type="checkbox"/>	<input type="checkbox"/>	<input type="checkbox"/>	<input type="checkbox"/>	<input type="checkbox"/>	<input type="checkbox"/>	<input type="checkbox"/>
B Band						E Band			E						
B1			B2			B3			E						
425	450	475	500	525	550	575	600	625	650	675	700	725	750	775	800
<input type="checkbox"/>	<input type="checkbox"/>	<input type="checkbox"/>	<input type="checkbox"/>	<input type="checkbox"/>	<input type="checkbox"/>	<input type="checkbox"/>	<input type="checkbox"/>	<input type="checkbox"/>	<input type="checkbox"/>	<input type="checkbox"/>	<input type="checkbox"/>	<input type="checkbox"/>	<input type="checkbox"/>	<input type="checkbox"/>	<input type="checkbox"/>
F Band			C Band						C						
F			C1			C2			C3						
825	850	875	900	925	950	975	1000	1025	1050	1075	1100	1125	1150	1175	1200
<input type="checkbox"/>	<input type="checkbox"/>	<input type="checkbox"/>	<input type="checkbox"/>	<input type="checkbox"/>	<input type="checkbox"/>	<input type="checkbox"/>	<input type="checkbox"/>	<input type="checkbox"/>	<input type="checkbox"/>	<input type="checkbox"/>	<input type="checkbox"/>	<input type="checkbox"/>	<input type="checkbox"/>	<input type="checkbox"/>	<input type="checkbox"/>
G Band			LTE Band			LTE			LTE						
G			LTE			LTE			LTE						
1225	1250	1275	1250												
<input checked="" type="checkbox"/>	<input checked="" type="checkbox"/>	<input checked="" type="checkbox"/>	<input type="checkbox"/>	<input type="checkbox"/>	<input type="checkbox"/>	<input type="checkbox"/>	<input type="checkbox"/>	<input type="checkbox"/>	<input type="checkbox"/>	<input type="checkbox"/>	<input type="checkbox"/>	<input type="checkbox"/>	<input type="checkbox"/>	<input type="checkbox"/>	<input type="checkbox"/>

Skip Apply

Setup Wizard

Manual Setup Wizard for 1900MHz Band (Choosing antenna)

- After selecting an antenna type, click 'Apply' button.
- Also User may skip this setting if it is not needed.

Antenna Only (AGS Setting): Repeater sets up automatically (Auto Gain Setting, AGS)

DAS (ALC D/L limit 7dBm Setting): Repeater operates with Active DAS

DAS (ALC D/L limit Maximum Setting): Repeater operates with Passive DAS

Not Use (HPA OFF): It disables this AMP unit

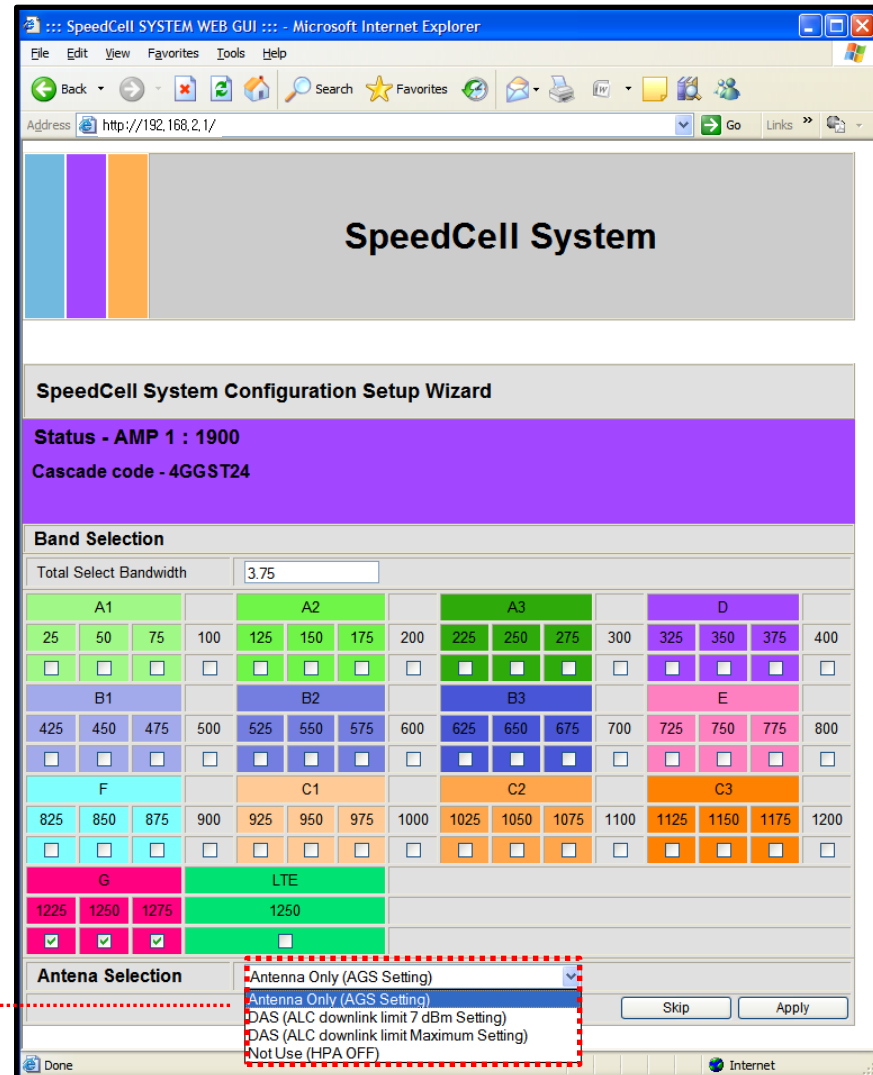

SpeedCell System Configuration Setup Wizard

Status - AMP 1 : 1900
Cascade code - 4GGST24

Band Selection

Total Select Bandwidth: 3.75

A1			A2			A3			D						
25	50	75	100	125	150	175	200	225	250	275	300	325	350	375	400
<input type="checkbox"/>	<input type="checkbox"/>	<input type="checkbox"/>	<input type="checkbox"/>	<input type="checkbox"/>	<input type="checkbox"/>	<input type="checkbox"/>	<input type="checkbox"/>	<input type="checkbox"/>	<input type="checkbox"/>	<input type="checkbox"/>	<input type="checkbox"/>	<input type="checkbox"/>	<input type="checkbox"/>	<input type="checkbox"/>	<input type="checkbox"/>
B1			B2			B3			E						
425	450	475	500	525	550	575	600	625	650	675	700	725	750	775	800
<input type="checkbox"/>	<input type="checkbox"/>	<input type="checkbox"/>	<input type="checkbox"/>	<input type="checkbox"/>	<input type="checkbox"/>	<input type="checkbox"/>	<input type="checkbox"/>	<input type="checkbox"/>	<input type="checkbox"/>	<input type="checkbox"/>	<input type="checkbox"/>	<input type="checkbox"/>	<input type="checkbox"/>	<input type="checkbox"/>	<input type="checkbox"/>
F			C1			C2			C3						
825	850	875	900	925	950	975	1000	1025	1050	1075	1100	1125	1150	1175	1200
<input type="checkbox"/>	<input type="checkbox"/>	<input type="checkbox"/>	<input type="checkbox"/>	<input type="checkbox"/>	<input type="checkbox"/>	<input type="checkbox"/>	<input type="checkbox"/>	<input type="checkbox"/>	<input type="checkbox"/>	<input type="checkbox"/>	<input type="checkbox"/>	<input type="checkbox"/>	<input type="checkbox"/>	<input type="checkbox"/>	<input type="checkbox"/>
G			LTE												
1225	1250	1275		1250											
<input checked="" type="checkbox"/>	<input checked="" type="checkbox"/>	<input checked="" type="checkbox"/>		<input type="checkbox"/>											

Antenna Selection

- Antenna Only (AGS Setting)
- Antenna Only (AGS Setting)
- DAS (ALC downlink limit 7 dBm Setting)
- DAS (ALC downlink limit Maximum Setting)
- Not Use (HPA OFF)

Skip Apply

Setup Wizard

Manual Setup Wizard for 800/900MHz Band

- User may choose bandwidth in this menu. After selecting bandwidth, click „Apply’ button.
- Also User may skip this setting if it is not needed.

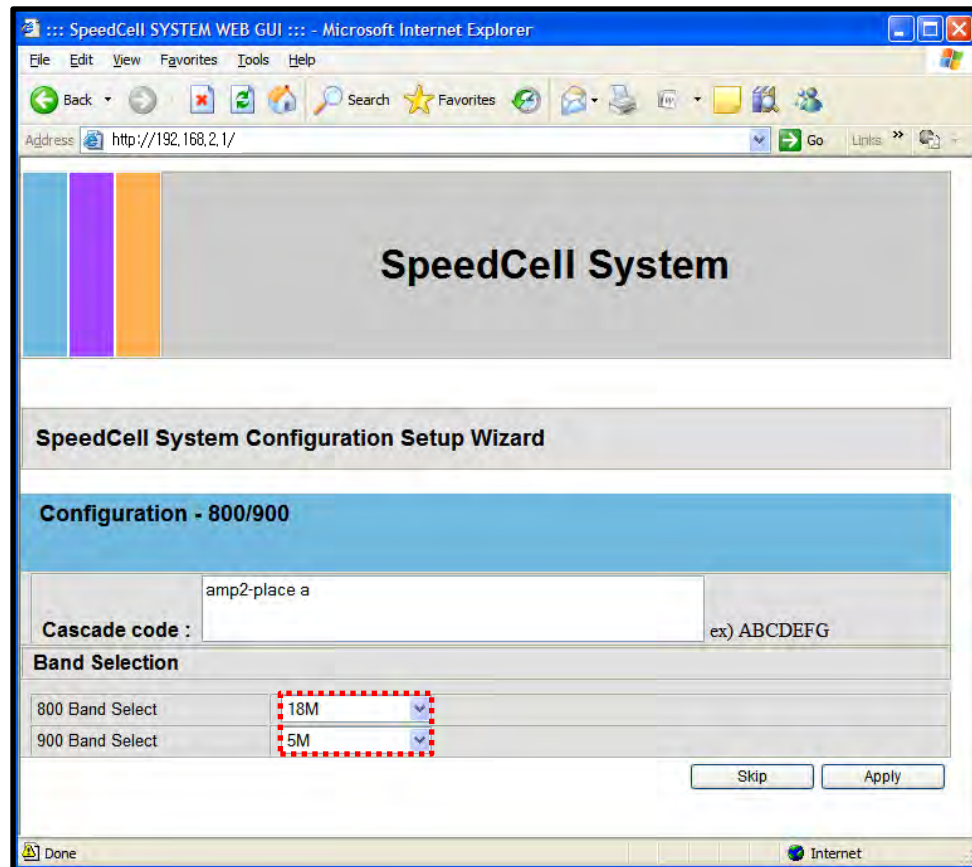

Setup Wizard

Manual Setup Wizard for 800/900MHz Band (Choosing antenna)

- After selecting an antenna type, click „Apply’ button.
- Also User may skip this setting if it is not needed.

Antenna Only (AGS Setting): Repeater sets up automatically (Auto Gain Setting, AGS)

DAS (ALC D/L limit 7dBm Setting):
Repeater operates with Active DAS

DAS (ALC D/L limit Maximum Setting):
Repeater operates with Passive DAS

Not Use (HPA OFF): It disables this AMP unit

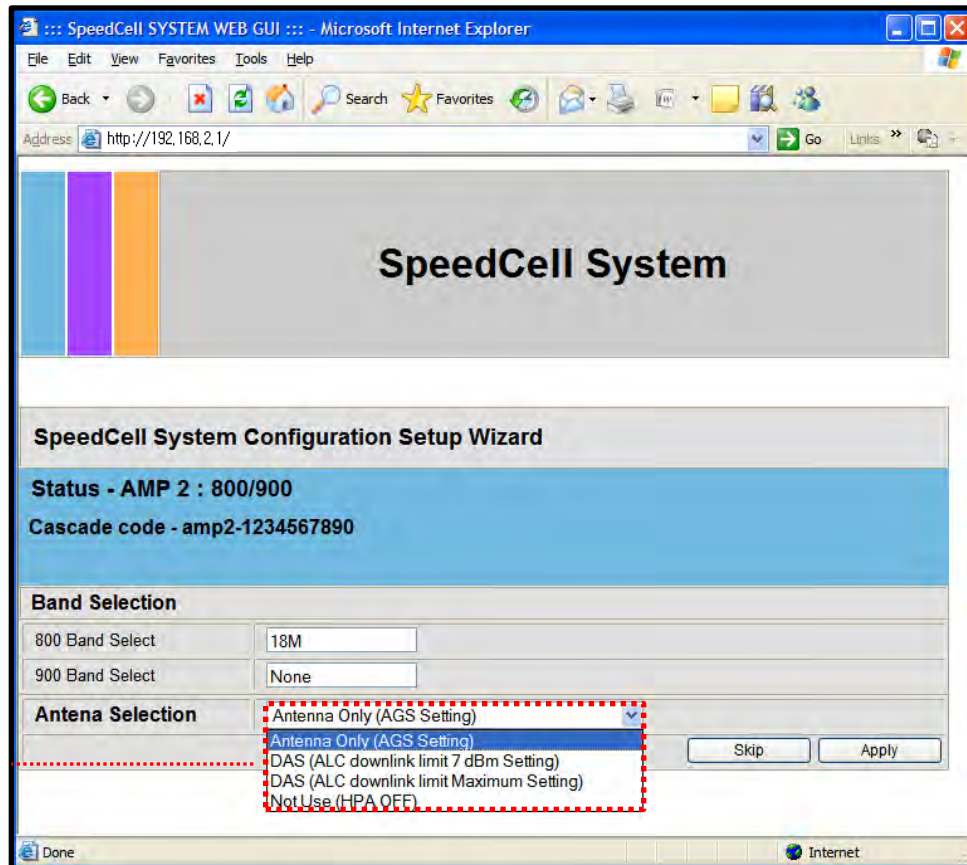

SpeedCell System Configuration Setup Wizard

Status - AMP 2 : 800/900
Cascade code - amp2-1234567890

Band Selection

800 Band Select: 18M
900 Band Select: None

Antena Selection

Antenna Only (AGS Setting) [Selected]
DAS (ALC downlink limit 7 dBm Setting)
DAS (ALC downlink limit Maximum Setting)
Not Use (HPA OFF)

Skip Apply

List Menu

- After clicking on „Main Page’, the „List Menu’ will be displayed.
- User may check the Repeater status by clicking on „Status’.

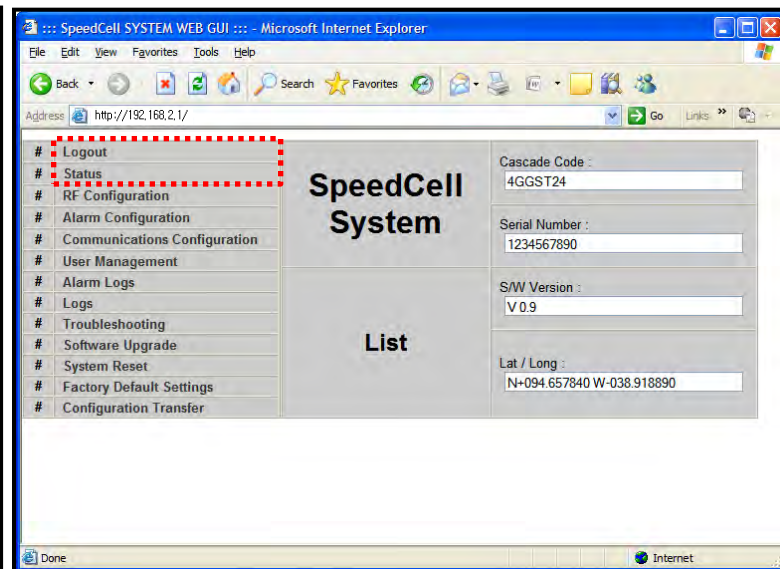
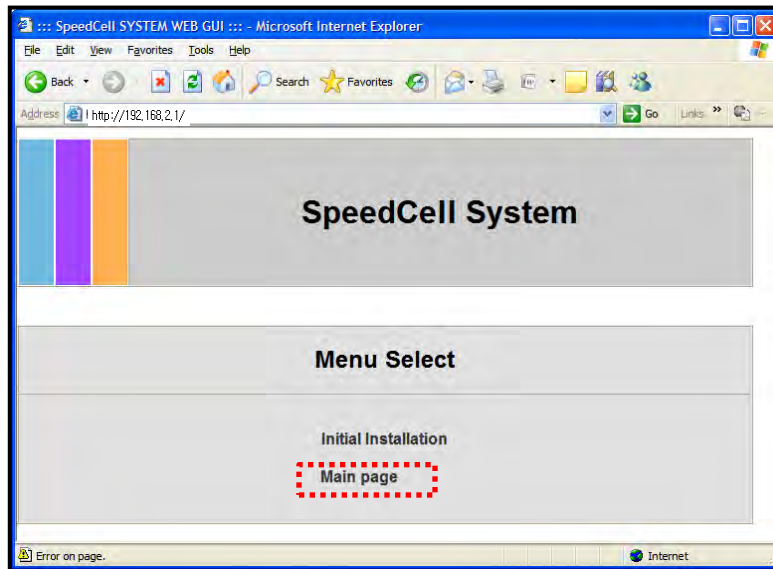

Status Menu

- User may check status of amplifiers by clicking on any of them.

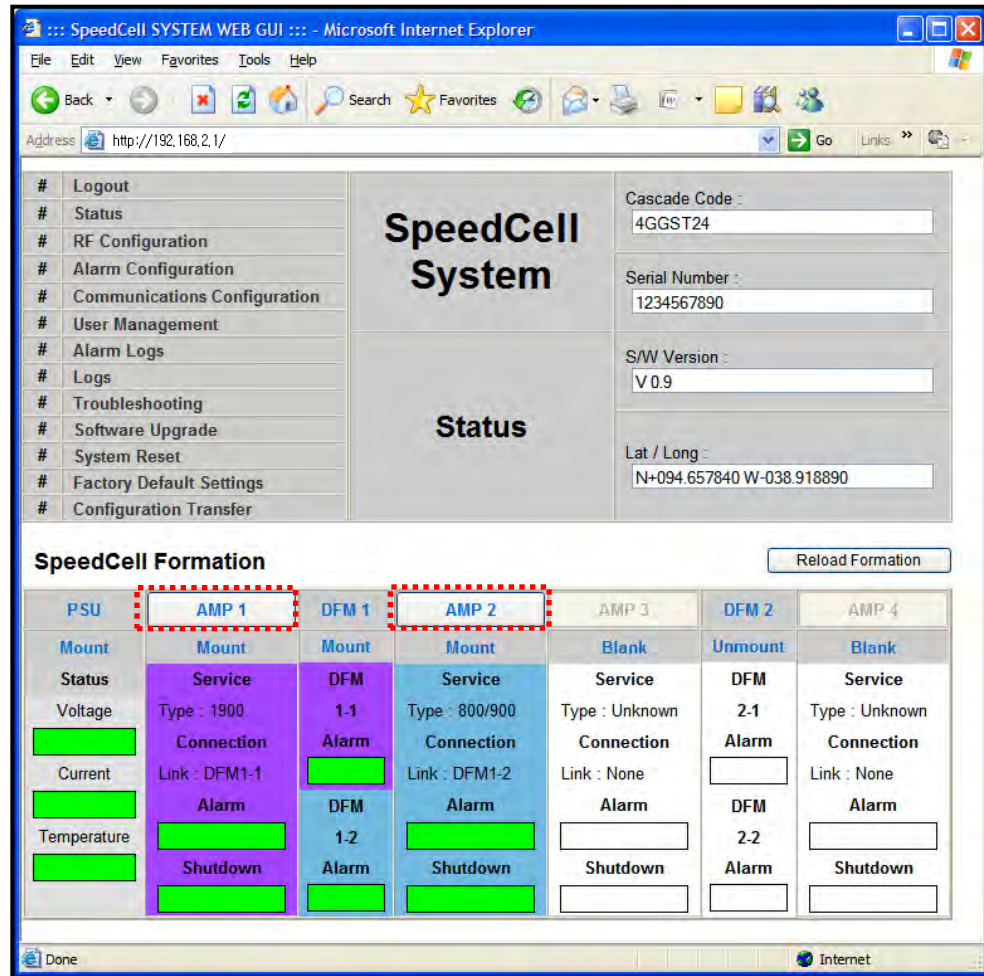

The screenshot shows the SpeedCell SYSTEM WEB GUI in Microsoft Internet Explorer. The browser address bar shows `http://192.168.2.1/`. The main content area is titled "SpeedCell System" and "Status". On the left, there is a navigation menu with the following items: Logout, Status, RF Configuration, Alarm Configuration, Communications Configuration, User Management, Alarm Logs, Logs, Troubleshooting, Software Upgrade, System Reset, Factory Default Settings, and Configuration Transfer. On the right, there are input fields for Cascade Code (4GGST24), Serial Number (1234567890), S/W Version (V 0.9), and Lat / Long (N+094.657840 W-038.918890).

Below the status information is the "SpeedCell Formation" section, which includes a "Reload Formation" button and a table of formation details. The table has columns for PSU, AMP 1, DFM 1, AMP 2, AMP 3, DFM 2, and AMP 4. The AMP 1 and AMP 2 columns are highlighted with red dashed boxes. The table rows include Mount, Status, Voltage, Current, and Temperature.

PSU	AMP 1	DFM 1	AMP 2	AMP 3	DFM 2	AMP 4
Mount	Mount	Mount	Mount	Blank	Unmount	Blank
Status	Service	DFM	Service	Service	DFM	Service
Voltage	Type : 1900	1-1	Type : 800/900	Type : Unknown	2-1	Type : Unknown
Current	Connection	Alarm	Connection	Connection	Alarm	Connection
Temperature	Link : DFM1-1	DFM	Link : DFM1-2	Link : None	DFM	Link : None
	Alarm	1-2	Alarm	Alarm	2-2	Alarm
	Shutdown	Alarm	Shutdown	Shutdown	Alarm	Shutdown

Status Menu

Status of 1900 AMP

- Default D/L and U/L are set at minimum gain.
- Values will vary depending on specific site circumstances.
- In case that screen resolution is 1024 x 768, you may need to use scroll bar to view all.

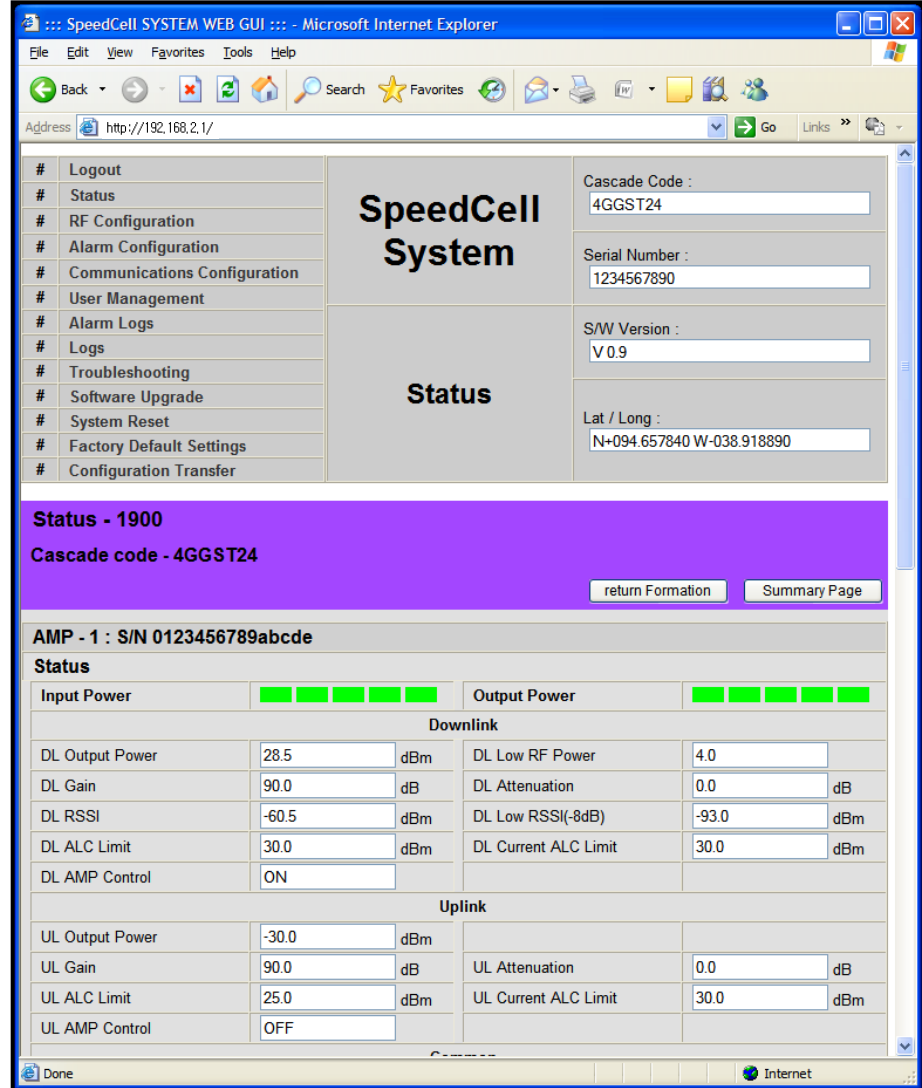

SpeedCell SYSTEM WEB GUI ::: - Microsoft Internet Explorer

Address <http://192.168.2.1/>

SpeedCell System

Status

Cascade Code : 4GGST24

Serial Number : 1234567890

S/W Version : V 0.9

Lat / Long : N+094.657840 W-038.918890

Status - 1900

Cascade code - 4GGST24

[return Formation](#) [Summary Page](#)

AMP - 1 : S/N 0123456789abcde

Status

Input Power ■ ■ ■ ■ ■ ■ ■ ■ Output Power ■ ■ ■ ■ ■ ■ ■ ■

Downlink

DL Output Power	28.5	dBm	DL Low RF Power	4.0	
DL Gain	90.0	dB	DL Attenuation	0.0	dB
DL RSSI	-60.5	dBm	DL Low RSSI(-8dB)	-93.0	dBm
DL ALC Limit	30.0	dBm	DL Current ALC Limit	30.0	dBm
DL AMP Control	ON				

Uplink

UL Output Power	-30.0	dBm			
UL Gain	90.0	dB	UL Attenuation	0.0	dB
UL ALC Limit	25.0	dBm	UL Current ALC Limit	30.0	dBm
UL AMP Control	OFF				

Done Internet

Status Menu

Status of 1900 AMP (continue of the page)

- Values will vary depending on specific site circumstances.
- In case that screen resolution is 1024 x 768, you may need to use scroll bar to view all.

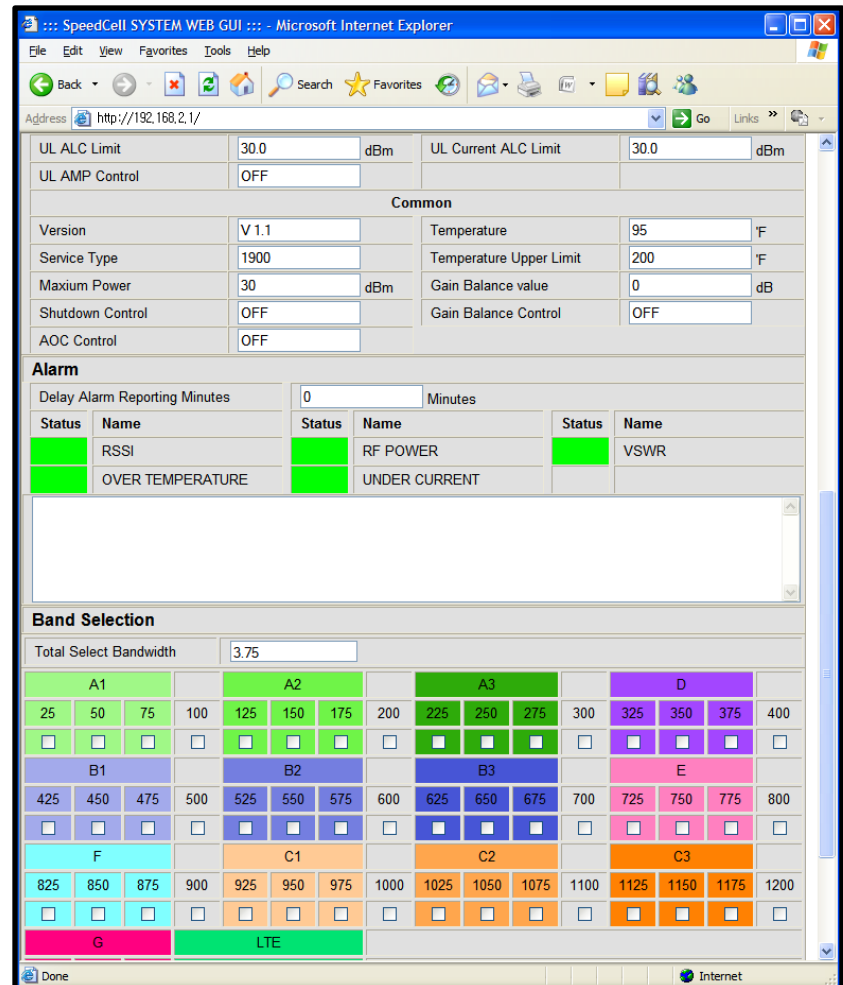

The screenshot displays the SpeedCell SYSTEM WEB GUI. The address bar shows `http://192.168.2.1/`. The interface includes several configuration sections:

- UL ALC Limit:** 30.0 dBm
- UL AMP Control:** OFF
- UL Current ALC Limit:** 30.0 dBm
- Common Section:**
 - Version: V 1.1
 - Service Type: 1900
 - Maximum Power: 30 dBm
 - Shutdown Control: OFF
 - AOC Control: OFF
 - Temperature: 95 °F
 - Temperature Upper Limit: 200 °F
 - Gain Balance value: 0 dB
 - Gain Balance Control: OFF
- Alarm Section:**
 - Delay Alarm Reporting Minutes: 0
 - Alarm Status Table:

Status	Name	Status	Name	Status	Name
■	RSSI	■	RF POWER	■	VSWR
■	OVER TEMPERATURE	■	UNDER CURRENT		
- Band Selection Section:**
 - Total Select Bandwidth: 3.75
 - Grid of frequency bands (A1, A2, A3, B1, B2, B3, C1, C2, C3, D, E, F, G, LTE) with checkboxes for selection.

Status Menu

Status of 1900 AMP (continue of the page)

- Values will vary depending on specific site circumstances.
- In case that screen resolution is 1024 x 768, you may need to use scroll bar to view all.

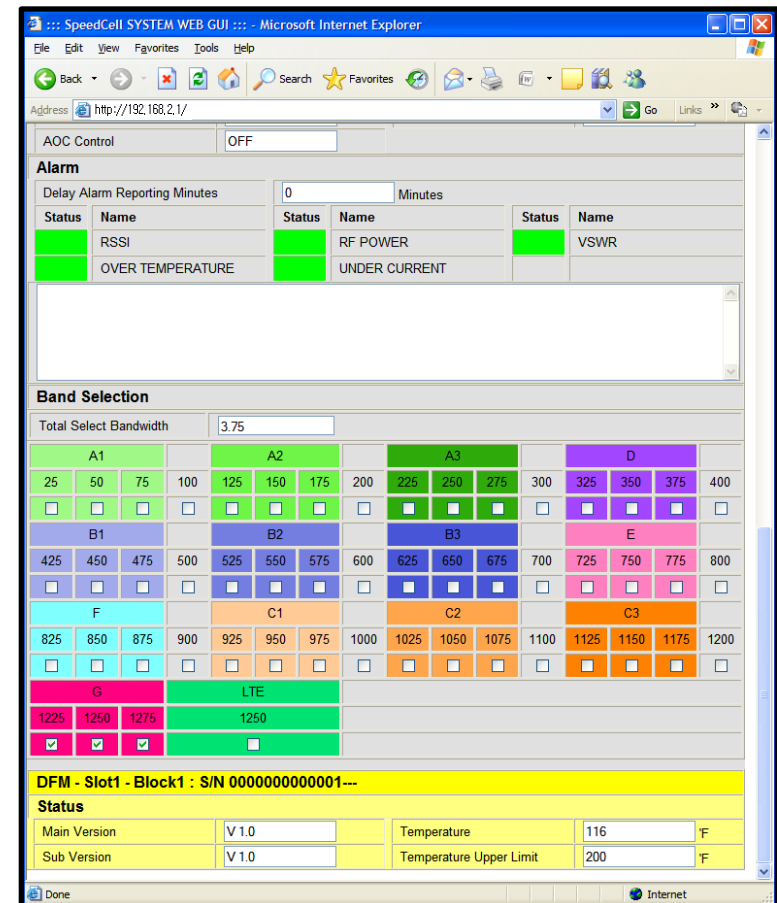

The screenshot displays the SpeedCell SYSTEM WEB GUI. The browser title is "SpeedCell SYSTEM WEB GUI :: - Microsoft Internet Explorer". The address bar shows "http://192.168.2.1/".

AOC Control: OFF

Alarm

Delay Alarm Reporting Minutes: 0 Minutes

Status	Name	Status	Name	Status	Name
Green	RSSI	Green	RF POWER	Green	VSWR
Green	OVER TEMPERATURE	Green	UNDER CURRENT		

Band Selection

Total Select Bandwidth: 3.75

A1			A2			A3			D						
25	50	75	100	125	150	175	200	225	250	275	300	325	350	375	400
<input type="checkbox"/>	<input type="checkbox"/>	<input type="checkbox"/>	<input type="checkbox"/>	<input type="checkbox"/>	<input type="checkbox"/>	<input type="checkbox"/>	<input type="checkbox"/>	<input type="checkbox"/>	<input type="checkbox"/>	<input type="checkbox"/>	<input type="checkbox"/>	<input type="checkbox"/>	<input type="checkbox"/>	<input type="checkbox"/>	<input type="checkbox"/>
B1			B2			B3			E						
425	450	475	500	525	550	575	600	625	650	675	700	725	750	775	800
<input type="checkbox"/>	<input type="checkbox"/>	<input type="checkbox"/>	<input type="checkbox"/>	<input type="checkbox"/>	<input type="checkbox"/>	<input type="checkbox"/>	<input type="checkbox"/>	<input type="checkbox"/>	<input type="checkbox"/>	<input type="checkbox"/>	<input type="checkbox"/>	<input type="checkbox"/>	<input type="checkbox"/>	<input type="checkbox"/>	<input type="checkbox"/>
F			C1			C2			C3						
825	850	875	900	925	950	975	1000	1025	1050	1075	1100	1125	1150	1175	1200
<input type="checkbox"/>	<input type="checkbox"/>	<input type="checkbox"/>	<input type="checkbox"/>	<input type="checkbox"/>	<input type="checkbox"/>	<input type="checkbox"/>	<input type="checkbox"/>	<input type="checkbox"/>	<input type="checkbox"/>	<input type="checkbox"/>	<input type="checkbox"/>	<input type="checkbox"/>	<input type="checkbox"/>	<input type="checkbox"/>	<input type="checkbox"/>
G			LTE												
1225	1250	1275	1250												
<input checked="" type="checkbox"/>	<input checked="" type="checkbox"/>	<input checked="" type="checkbox"/>	<input type="checkbox"/>												

DFM - Slot1 - Block1 : S/N 000000000001---

Status

Main Version	V 1.0	Temperature	116	°F
Sub Version	V 1.0	Temperature Upper Limit	200	°F

Status Menu

Status of 800/900 AMP

- Default D/L and U/L are set at minimum gain.
- Values will vary depending on specific site circumstances.
- In case that screen resolution is 1024 x 768, you may need to use scroll bar to view all.

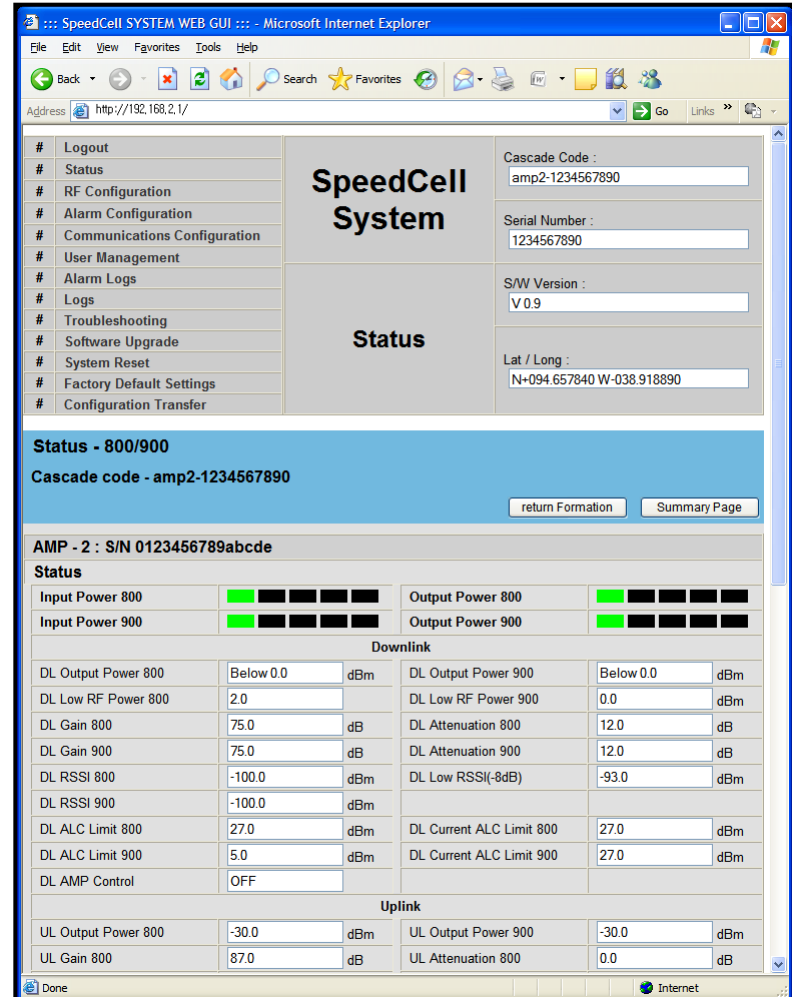

SpeedCell System

Status

Cascade Code : amp2-1234567890

Serial Number : 1234567890

S/W Version : V 0.9

Lat / Long : N+094.657840 W-038.918890

Status - 800/900

Cascade code - amp2-1234567890

[return Formation](#) [Summary Page](#)

AMP - 2 : S/N 0123456789abcde

Status

Input Power 800		Output Power 800	
Input Power 900		Output Power 900	

Downlink

DL Output Power 800	Below 0.0	dBm	DL Output Power 900	Below 0.0	dBm
DL Low RF Power 800	2.0	dBm	DL Low RF Power 900	0.0	dBm
DL Gain 800	75.0	dB	DL Attenuation 800	12.0	dB
DL Gain 900	75.0	dB	DL Attenuation 900	12.0	dB
DL RSSI 800	-100.0	dBm	DL Low RSSI(-8dB)	-93.0	dBm
DL RSSI 900	-100.0	dBm			
DL ALC Limit 800	27.0	dBm	DL Current ALC Limit 800	27.0	dBm
DL ALC Limit 900	5.0	dBm	DL Current ALC Limit 900	27.0	dBm
DL AMP Control	OFF				

Uplink

UL Output Power 800	-30.0	dBm	UL Output Power 900	-30.0	dBm
UL Gain 800	87.0	dB	UL Attenuation 800	0.0	dB

Status Menu

Status of 800/900 AMP (continue of the page)

- Values will vary depending on specific site circumstances.
- In case that screen resolution is 1024 x 768, you may need to use scroll bar to view all.

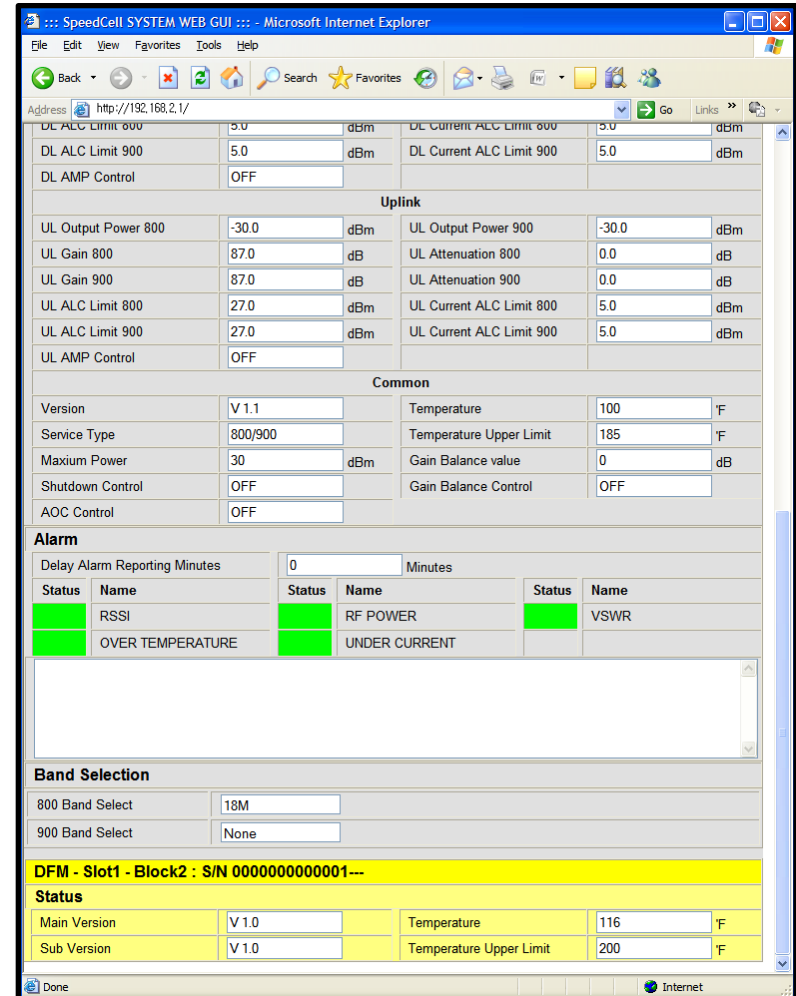

SpeedCell SYSTEM WEB GUI - Microsoft Internet Explorer

Address: http://192.168.2.1/

DL ALC Limit 800	5.0	dBm	DL Current ALC Limit 800	5.0	dBm
DL ALC Limit 900	5.0	dBm	DL Current ALC Limit 900	5.0	dBm
DL AMP Control	OFF				

Uplink

UL Output Power 800	-30.0	dBm	UL Output Power 900	-30.0	dBm
UL Gain 800	87.0	dB	UL Attenuation 800	0.0	dB
UL Gain 900	87.0	dB	UL Attenuation 900	0.0	dB
UL ALC Limit 800	27.0	dBm	UL Current ALC Limit 800	5.0	dBm
UL ALC Limit 900	27.0	dBm	UL Current ALC Limit 900	5.0	dBm
UL AMP Control	OFF				

Common

Version	V 1.1	Temperature	100	°F	
Service Type	800/900	Temperature Upper Limit	185	°F	
Maximum Power	30	dBm	Gain Balance value	0	dB
Shutdown Control	OFF		Gain Balance Control	OFF	
AOC Control	OFF				

Alarm

Delay Alarm Reporting Minutes: 0 Minutes

Status	Name	Status	Name	Status	Name
Green	RSSI	Green	RF POWER	Green	VSWR
Green	OVER TEMPERATURE	Green	UNDER CURRENT		

Band Selection

800 Band Select	18M
900 Band Select	None

DFM - Slot1 - Block2 : S/N 000000000001---

Status

Main Version	V 1.0	Temperature	116	°F
Sub Version	V 1.0	Temperature Upper Limit	200	°F

RF Configuration Menu

- Click the RF Configuration link.
- Click AMP 1 or AMP 2 in order to go to the next window and change RF values.

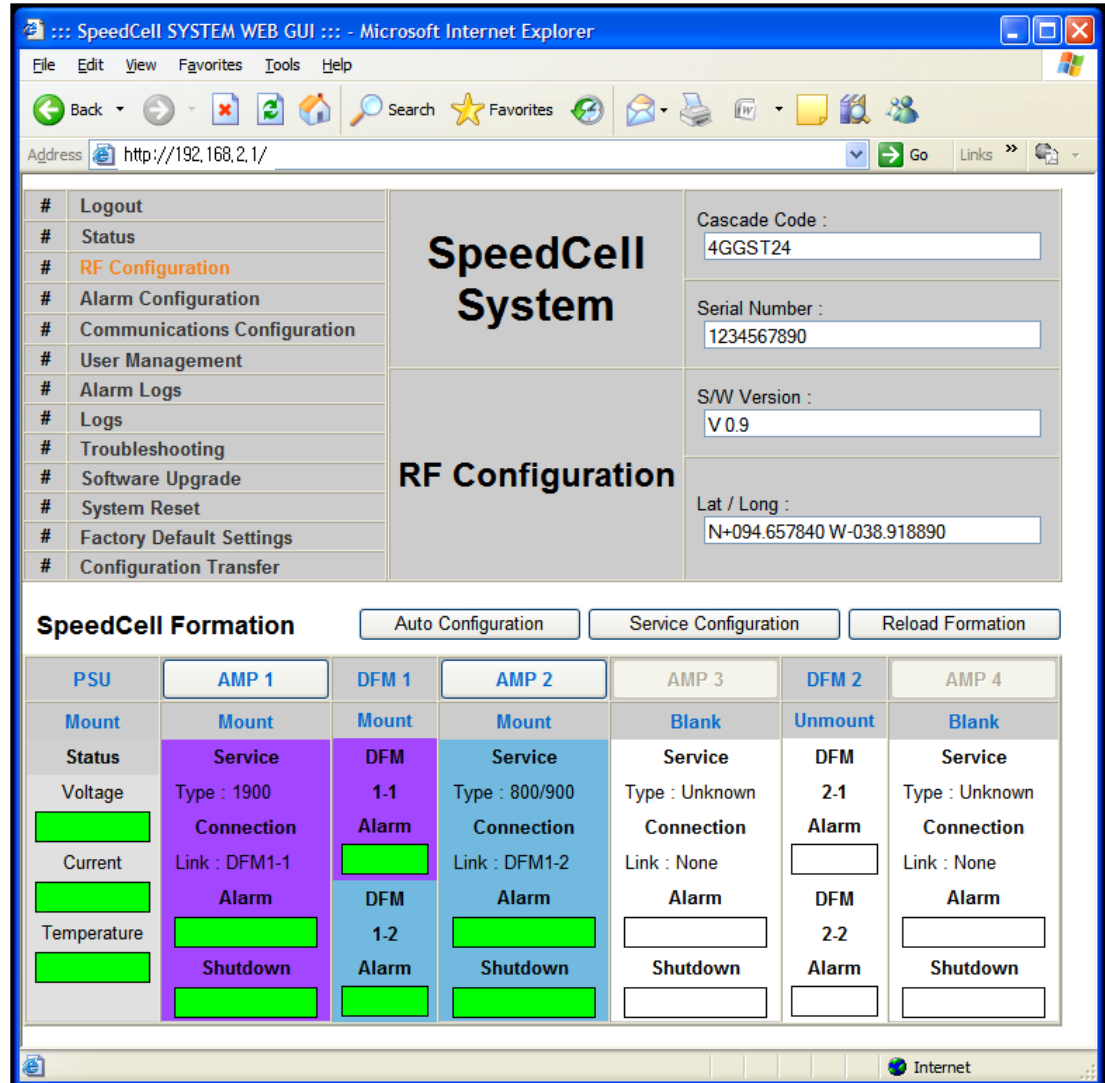

SpeedCell Formation

PSU	AMP 1	DFM 1	AMP 2	AMP 3	DFM 2	AMP 4
Mount	Mount	Mount	Mount	Blank	Unmount	Blank
Status	Service	DFM	Service	Service	DFM	Service
Voltage	Type : 1900	1-1	Type : 800/900	Type : Unknown	2-1	Type : Unknown
Current	Connection	Alarm	Connection	Connection	Alarm	Connection
Temperature	Link : DFM1-1	DFM	Link : DFM1-2	Link : None	DFM	Link : None
	Alarm	1-2	Alarm	Alarm	2-2	Alarm
	Shutdown	Alarm	Shutdown	Shutdown	Alarm	Shutdown

RF Configuration Menu FAQ's

• What is Auto Limit Control (ALC)?

ALC is used for custom installations.

If the repeater is having difficulties with isolation check, or if you want to “power down” the repeater ALC should be manually set. Attenuation may also be added for reducing power levels. ALC also provides optional U/L and D/L settings.

- ALC controls the output power.
- If you want to use the ALC function, Gain Balance Control should be turned off.
- ALC will reduce max gain by the set value even if the input signal decreases.
- ALC should be used if the repeater is connected to a DAS system.

• What does the Shutdown ON/OFF control?

- An internal wave-detection is checking the noise level. If the repeater cannot secure isolation it will go through a process of turning itself off, and turning back on while doing isolation checking.
- If it is impossible for the repeater to secure isolation after 30 minutes, the repeater will shut down and stay shutdown. The items that may automatically require the repeater to shut down are:
 - > VSWR Alarm, Over Power Alarm, Over Input Alarm, and Temperature Alarm.

• What is Gain Balance Control?

- Gain Balance Control will always keep the UL and DL ATT the same while using AGC. GBC should always be left on to prevent damage to BTS while using AGC.
- This is used for BTS to cell phone power control.

Auto Gain Setting (AGS) Flow Chart

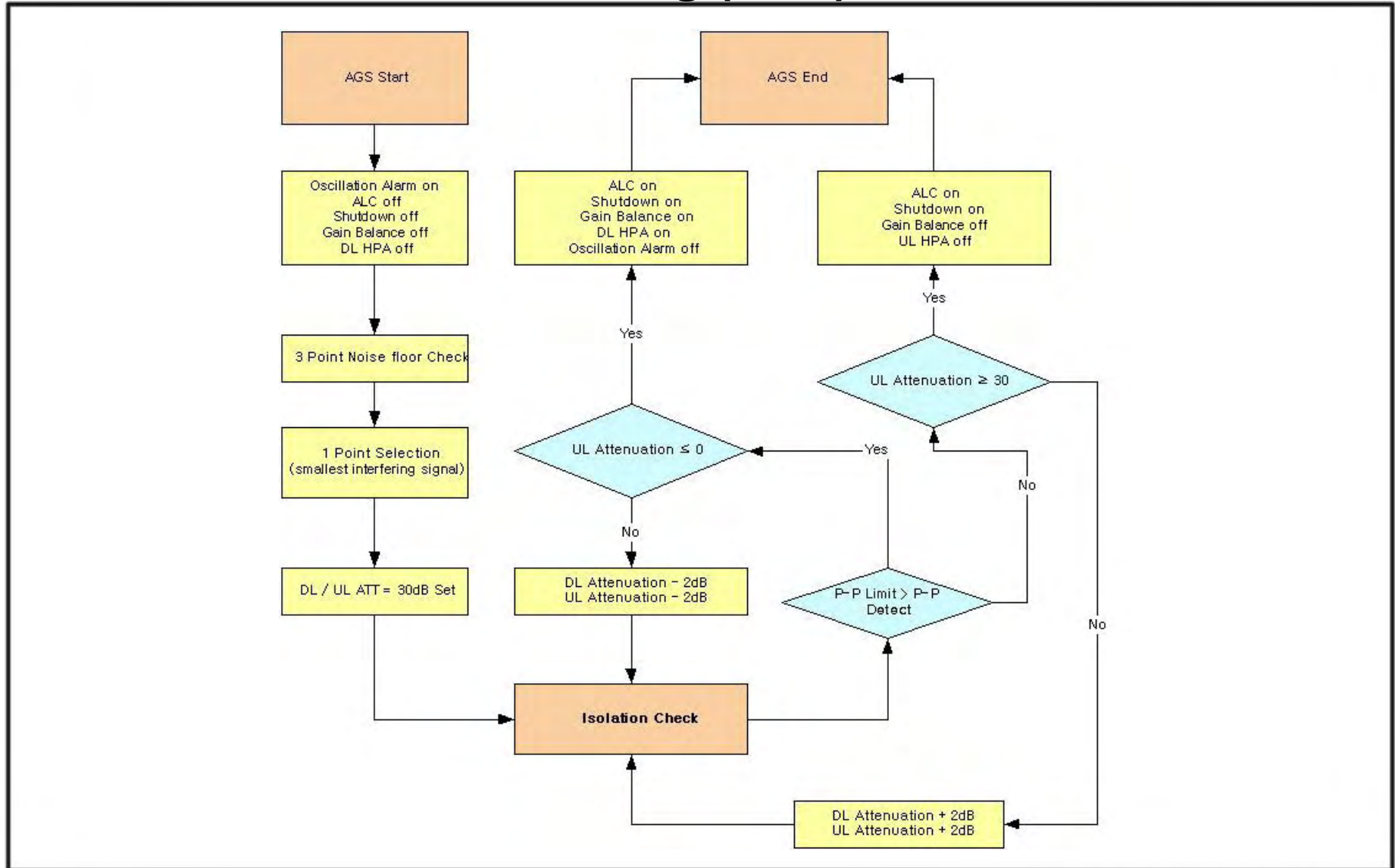

RF Configuration Menu

1900MHz Band Selection

Band Selection Algorithm

ITEM	BANDWIDTH	NOTE
Band Select	3 non-contiguous band is selectable	1.25 ~ 20MHz is selectable in each band

Band Structure

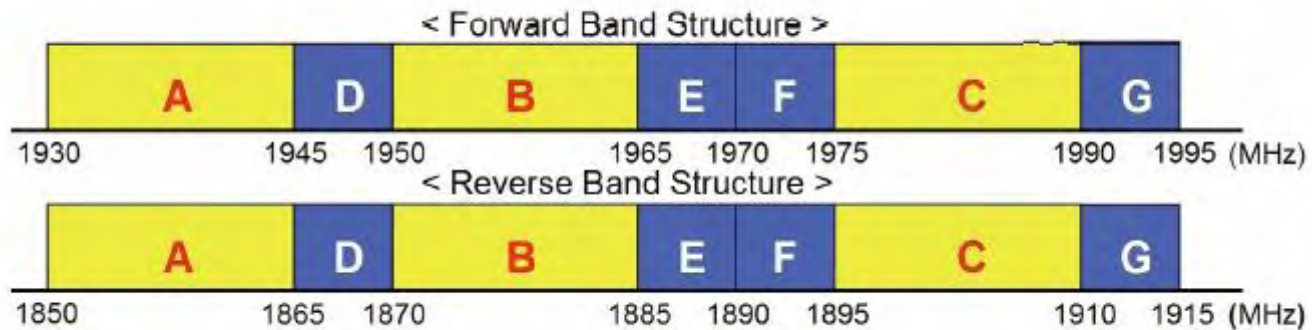

RF Configuration Menu

800/900MHz Band Selection

Band Select Status

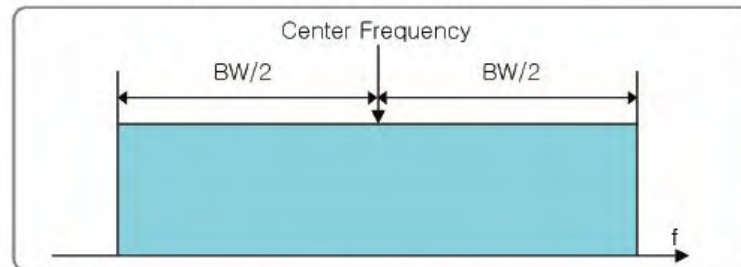

<System Filter Setting>

	Center Frequency	Bandwidth
iDEN800	860MHz	18MHz
	859.9MHz	17.8MHz
	859.8MHz	17.8MHz
	865.5MHz	7MHz
	865.4MHz	6.8MHz
	865.3MHz	6.6MHz
iDEN900	937.5MHz	5MHz
	937.4MHz	4.8MHz
	937.3MHz	4.6MHz

<Primary Center & Bandwidth>

RF Configuration Menu

- Click the RF Configuration link.
Click AMP 1 or AMP 2 in order to go to the next window and change RF values.

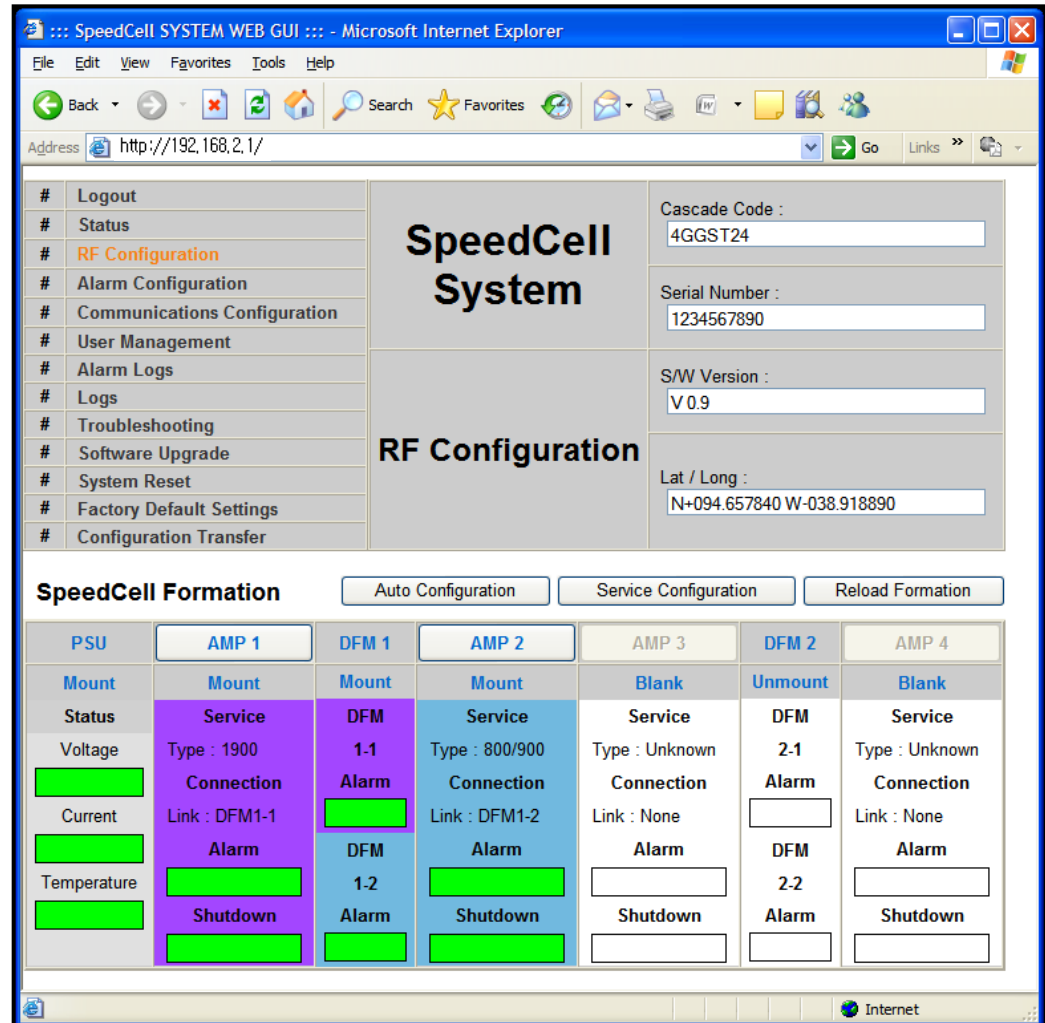

SpeedCell Formation

PSU	AMP 1	DFM 1	AMP 2	AMP 3	DFM 2	AMP 4
Mount	Mount	Mount	Mount	Blank	Unmount	Blank
Status	Service	DFM	Service	Service	DFM	Service
Voltage	Type : 1900	1-1	Type : 800/900	Type : Unknown	2-1	Type : Unknown
Current	Connection	Alarm	Connection	Connection	Alarm	Connection
Temperature	Link : DFM1-1	DFM	Link : DFM1-2	Link : None	DFM	Link : None
	Alarm	1-2	Alarm	Alarm	2-2	Alarm
	Shutdown	Alarm	Shutdown	Shutdown	Alarm	Shutdown

RF Configuration Menu

1900 AMP

- User may change various RF values of the repeater on this page.
- Changes will not take effect until you click “Apply” button.
- This menu is where the installer will choose references for specific implementation.
- In case that screen resolution is 1024 x 768, you may need to use scroll bar to view all.

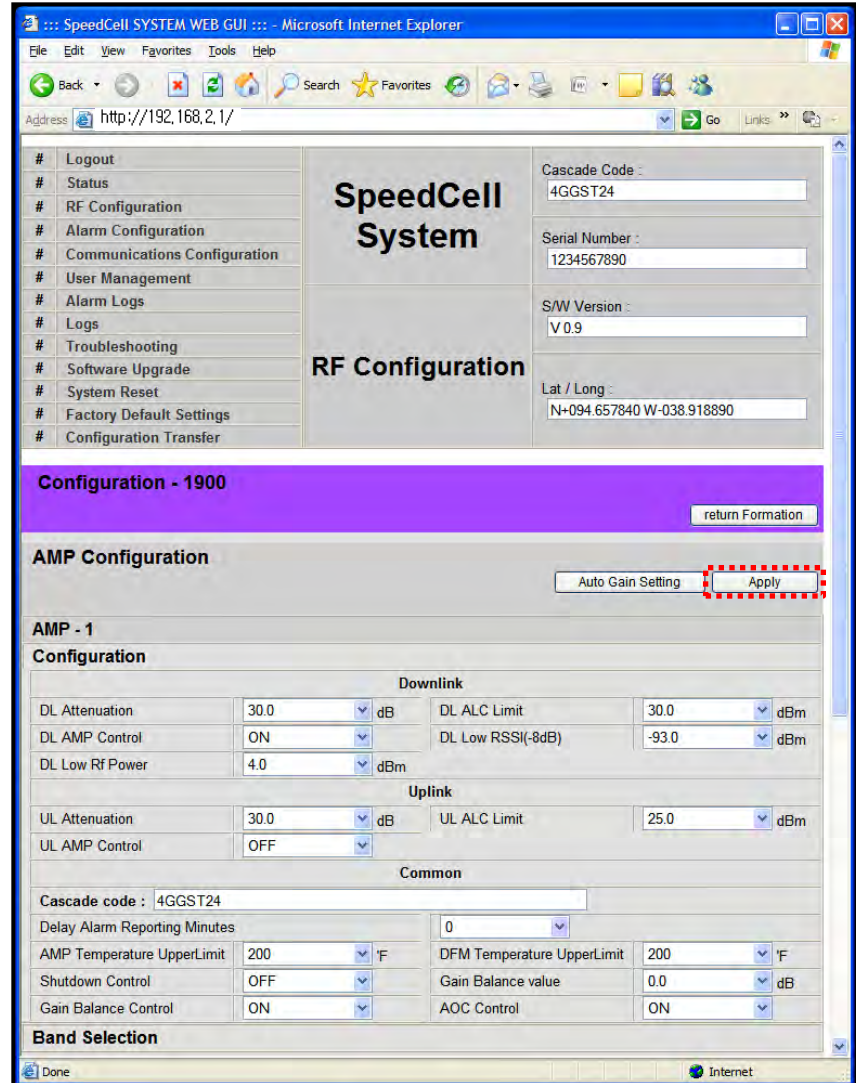

The screenshot displays the SpeedCell SYSTEM WEB GUI in Microsoft Internet Explorer. The browser address bar shows `http://192.168.2.1/`. The main content area is titled "SpeedCell System" and "RF Configuration". A navigation menu on the left lists various configuration options, with "RF Configuration" selected. The "Configuration - 1900" section is highlighted in purple and contains a "return Formation" button. Below this, the "AMP Configuration" section features an "Auto Gain Setting" dropdown and an "Apply" button, which is highlighted with a red dashed box. The "AMP - 1 Configuration" section is divided into "Downlink", "Uplink", and "Common" sub-sections, each containing several configuration fields with dropdown menus and input boxes.

Downlink			
DL Attenuation	30.0	dB	DL ALC Limit
DL AMP Control	ON		DL Low RSSI(-8dB)
DL Low RF Power	4.0	dBm	

Uplink	
UL Attenuation	30.0 dB
UL AMP Control	OFF
UL ALC Limit	25.0 dBm

Common			
Cascade code :	4GGST24		
Delay Alarm Reporting Minutes	0		
AMP Temperature UpperLimit	200	°F	DFM Temperature UpperLimit
Shutdown Control	OFF		Gain Balance value
Gain Balance Control	ON		AOC Control

RF Configuration Menu

1900 AMP (continue of the page)

- User may change various RF values of the repeater on this page.
- Changes will not take effect until you click “Apply” button.
- This menu is where the installer will choose references for specific implementation.
- In case that screen resolution is 1024 x 768, you may need to use scroll bar to view all.

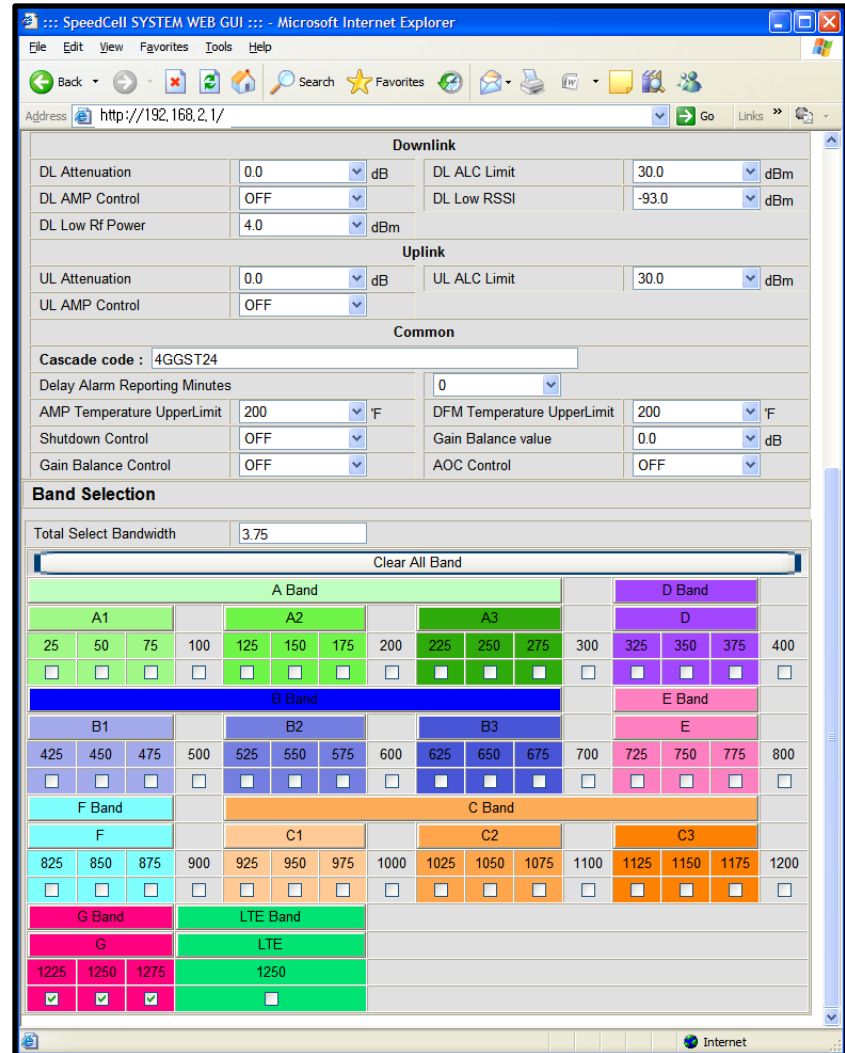

The screenshot displays the SpeedCell SYSTEM WEB GUI in Microsoft Internet Explorer. The address bar shows <http://192.168.2.1/>. The interface is divided into several sections:

- Downlink:** DL Attenuation (0.0 dB), DL AMP Control (OFF), DL Low Rf Power (4.0 dBm), DL ALC Limit (30.0 dBm), DL Low RSSI (-93.0 dBm).
- Uplink:** UL Attenuation (0.0 dB), UL AMP Control (OFF), UL ALC Limit (30.0 dBm).
- Common:** Cascade code (4GGST24), Delay Alarm Reporting Minutes (0), AMP Temperature UpperLimit (200 °F), Shutdown Control (OFF), Gain Balance Control (OFF), DFM Temperature UpperLimit (200 °F), Gain Balance value (0.0 dB), AOC Control (OFF).
- Band Selection:** Total Select Bandwidth (3.75). A grid of frequency bands is shown with checkboxes for selection. The bands include A Band (A1, A2, A3), B Band (B1, B2, B3), C Band (C1, C2, C3), D Band (D), E Band (E), F Band (F), G Band (G), and LTE Band (LTE). The G and LTE bands are currently selected.

RF Configuration Menu

800/900 AMP

- User may change various RF values of the repeater on this page.
- Changes will not take effect until you click “Apply” button.
- This menu is where the installer will choose references for specific implementation.
- In case that screen resolution is 1024 x 768, you may need to use scroll bar to view all.

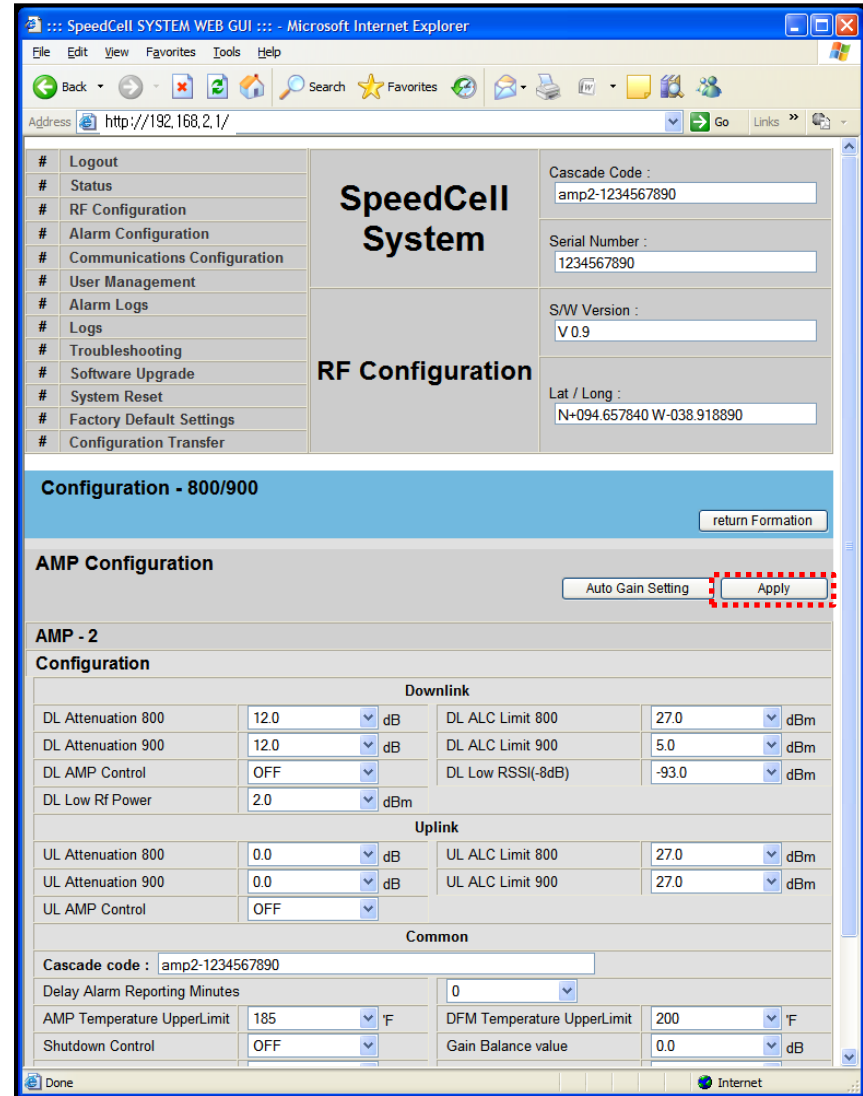

SpeedCell SYSTEM WEB GUI - Microsoft Internet Explorer

Address: http://192.168.2.1/

SpeedCell System

RF Configuration

Configuration - 800/900

return Formation

AMP Configuration

Auto Gain Setting

AMP - 2

Configuration

Downlink

DL Attenuation 800	12.0	dB	DL ALC Limit 800	27.0	dBm
DL Attenuation 900	12.0	dB	DL ALC Limit 900	5.0	dBm
DL AMP Control	OFF		DL Low RSSI(-8dB)	-93.0	dBm
DL Low Rf Power	2.0	dBm			

Uplink

UL Attenuation 800	0.0	dB	UL ALC Limit 800	27.0	dBm
UL Attenuation 900	0.0	dB	UL ALC Limit 900	27.0	dBm
UL AMP Control	OFF				

Common

Cascade code :	amp2-1234567890				
Delay Alarm Reporting Minutes	0				
AMP Temperature UpperLimit	185	F	DFM Temperature UpperLimit	200	F
Shutdown Control	OFF		Gain Balance value	0.0	dB

RF Configuration Menu

800/900 AMP (continue of the page)

- User may change various RF values of the repeater on this page.
- Changes will not take effect until you click “Apply” button.
- This menu is where the installer will choose references for specific implementation.
- In case that screen resolution is 1024 x 768, you may need to use scroll bar to view all.

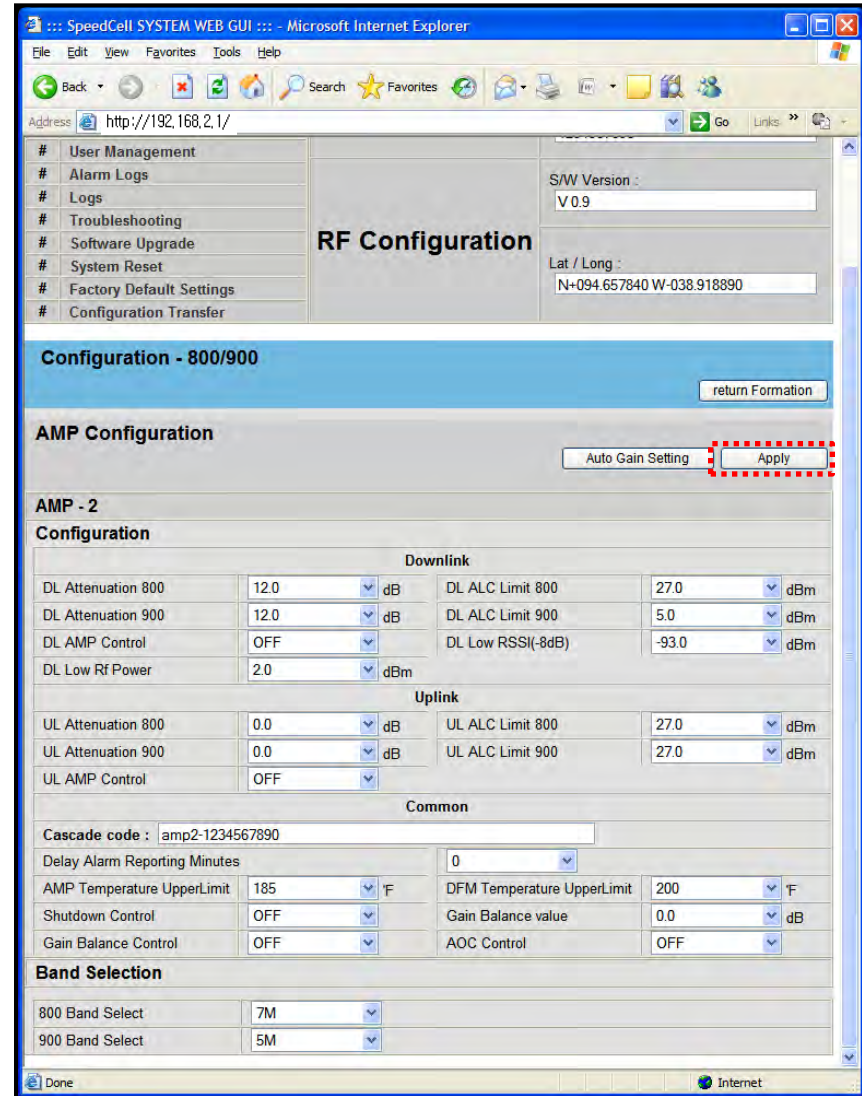

SpeedCell SYSTEM WEB GUI - Microsoft Internet Explorer

Address: http://192.168.2.1/

RF Configuration

S/W Version : V 0.9

Lat / Long : N+094.657840 W-038.918890

Configuration - 800/900

return Formation

AMP Configuration

Auto Gain Setting

AMP - 2

Configuration

Downlink

DL Attenuation 800	12.0	dB	DL ALC Limit 800	27.0	dBm
DL Attenuation 900	12.0	dB	DL ALC Limit 900	5.0	dBm
DL AMP Control	OFF		DL Low RSSI(-8dB)	-93.0	dBm
DL Low Rf Power	2.0	dBm			

Uplink

UL Attenuation 800	0.0	dB	UL ALC Limit 800	27.0	dBm
UL Attenuation 900	0.0	dB	UL ALC Limit 900	27.0	dBm
UL AMP Control	OFF				

Common

Cascade code : amp2-1234567890

Delay Alarm Reporting Minutes : 0

AMP Temperature UpperLimit	185	F	DFM Temperature UpperLimit	200	F
Shutdown Control	OFF		Gain Balance value	0.0	dB
Gain Balance Control	OFF		AOC Control	OFF	

Band Selection

800 Band Select	7M
900 Band Select	5M

Done Internet

Alarm Configuration Menu

- Click „1900’ link to check alarm configuration of 1900AMP.
- In case that Report Alarms is OFF, all alarms will be disabled. In case that Report Alarm is ON, you can enable and disable individual alarms.

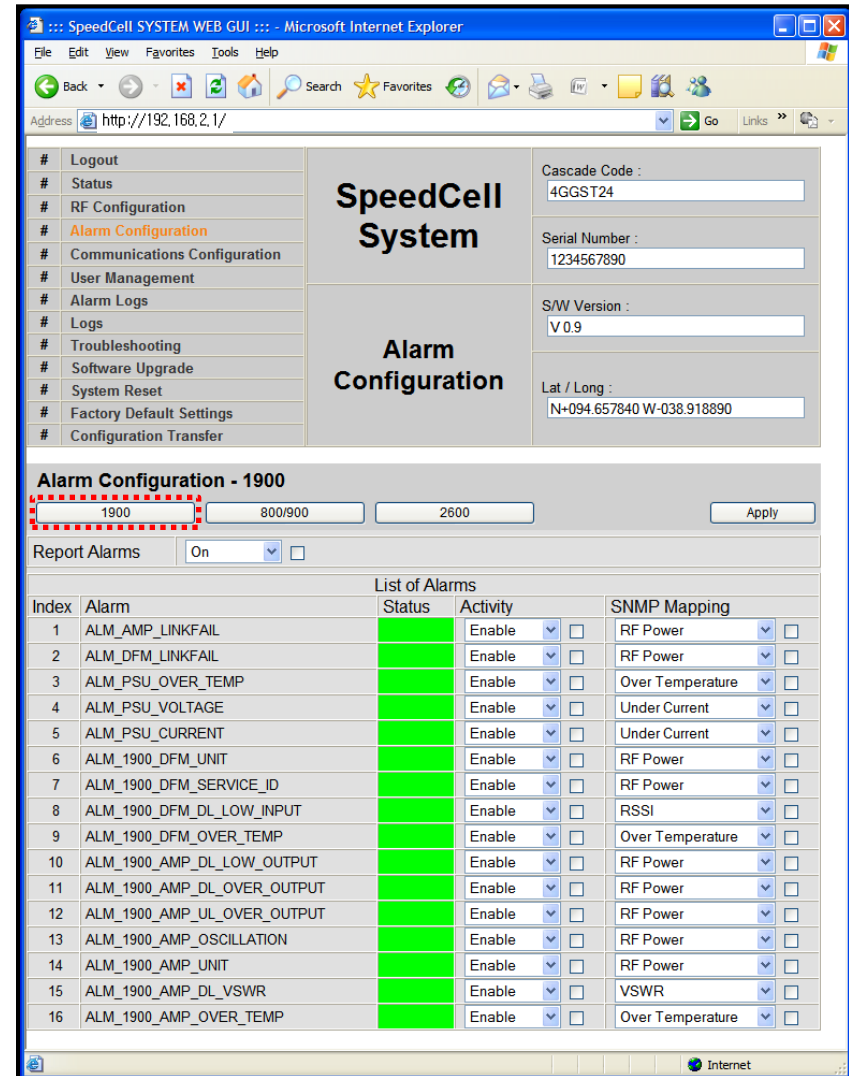

SpeedCell System Alarm Configuration

Cascade Code : 4GGST24
 Serial Number : 1234567890
 S/W Version : V 0.9
 Lat / Long : N+094.657840 W-038.918890

Alarm Configuration - 1900

1900 800/900 2600 Apply

Report Alarms On

Index	Alarm	Status	Activity	SNMP Mapping
1	ALM_AMP_LINKFAIL	Enable	Enable	RF Power
2	ALM_DFM_LINKFAIL	Enable	Enable	RF Power
3	ALM_PSU_OVER_TEMP	Enable	Enable	Over Temperature
4	ALM_PSU_VOLTAGE	Enable	Enable	Under Current
5	ALM_PSU_CURRENT	Enable	Enable	Under Current
6	ALM_1900_DFM_UNIT	Enable	Enable	RF Power
7	ALM_1900_DFM_SERVICE_ID	Enable	Enable	RF Power
8	ALM_1900_DFM_DL_LOW_INPUT	Enable	Enable	RSSI
9	ALM_1900_DFM_OVER_TEMP	Enable	Enable	Over Temperature
10	ALM_1900_AMP_DL_LOW_OUTPUT	Enable	Enable	RF Power
11	ALM_1900_AMP_DL_OVER_OUTPUT	Enable	Enable	RF Power
12	ALM_1900_AMP_UL_OVER_OUTPUT	Enable	Enable	RF Power
13	ALM_1900_AMP_OSCILLATION	Enable	Enable	RF Power
14	ALM_1900_AMP_UNIT	Enable	Enable	RF Power
15	ALM_1900_AMP_DL_VSWR	Enable	Enable	VSWR
16	ALM_1900_AMP_OVER_TEMP	Enable	Enable	Over Temperature

Alarm Configuration Menu

- Click „800/900’ link to check alarm configuration of 1900AMP.
- In case that Report Alarms is OFF, all alarms will be disabled. In case that Report Alarm is ON, you can enable and disable individual alarms.

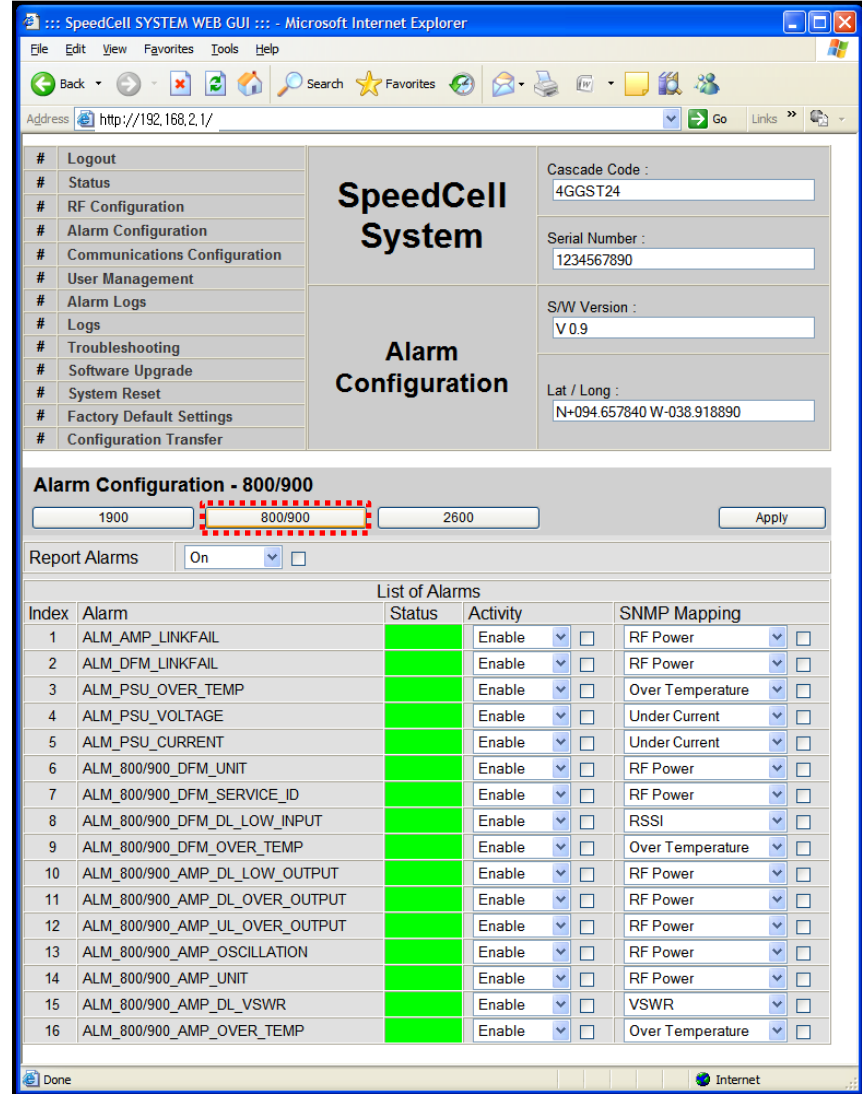

SpeedCell SYSTEM WEB GUI - Microsoft Internet Explorer

Address: http://192.168.2.1/

SpeedCell System

Cascade Code : 4GGST24

Serial Number : 1234567890

S/W Version : V 0.9

Lat / Long : N+094.657840 W-038.918890

Alarm Configuration

Alarm Configuration - 800/900

1900 **800/900** 2600 Apply

Report Alarms On

List of Alarms				
Index	Alarm	Status	Activity	SNMP Mapping
1	ALM_AMP_LINKFAIL	Enable	Enable <input type="checkbox"/>	RF Power <input type="checkbox"/>
2	ALM_DFM_LINKFAIL	Enable	Enable <input type="checkbox"/>	RF Power <input type="checkbox"/>
3	ALM_PSU_OVER_TEMP	Enable	Enable <input type="checkbox"/>	Over Temperature <input type="checkbox"/>
4	ALM_PSU_VOLTAGE	Enable	Enable <input type="checkbox"/>	Under Current <input type="checkbox"/>
5	ALM_PSU_CURRENT	Enable	Enable <input type="checkbox"/>	Under Current <input type="checkbox"/>
6	ALM_800/900_DFM_UNIT	Enable	Enable <input type="checkbox"/>	RF Power <input type="checkbox"/>
7	ALM_800/900_DFM_SERVICE_ID	Enable	Enable <input type="checkbox"/>	RF Power <input type="checkbox"/>
8	ALM_800/900_DFM_DL_LOW_INPUT	Enable	Enable <input type="checkbox"/>	RSSI <input type="checkbox"/>
9	ALM_800/900_DFM_OVER_TEMP	Enable	Enable <input type="checkbox"/>	Over Temperature <input type="checkbox"/>
10	ALM_800/900_AMP_DL_LOW_OUTPUT	Enable	Enable <input type="checkbox"/>	RF Power <input type="checkbox"/>
11	ALM_800/900_AMP_DL_OVER_OUTPUT	Enable	Enable <input type="checkbox"/>	RF Power <input type="checkbox"/>
12	ALM_800/900_AMP_UL_OVER_OUTPUT	Enable	Enable <input type="checkbox"/>	RF Power <input type="checkbox"/>
13	ALM_800/900_AMP_OSCILLATION	Enable	Enable <input type="checkbox"/>	RF Power <input type="checkbox"/>
14	ALM_800/900_AMP_UNIT	Enable	Enable <input type="checkbox"/>	RF Power <input type="checkbox"/>
15	ALM_800/900_AMP_DL_VSWR	Enable	Enable <input type="checkbox"/>	VSWR <input type="checkbox"/>
16	ALM_800/900_AMP_OVER_TEMP	Enable	Enable <input type="checkbox"/>	Over Temperature <input type="checkbox"/>

Communication Configuration Menu

- Click on the „Communications Configuration’ link.
- On this page you can change various values related to IP network. Because Web UI is based on IP network, incorrect configuration may make it impossible to connect to Web UI. In that case, you can troubleshoot as described in the Command Line Interface (CLI) section.
- In case that screen resolution is 1024 x 768, you may need to use scroll bar to view all.

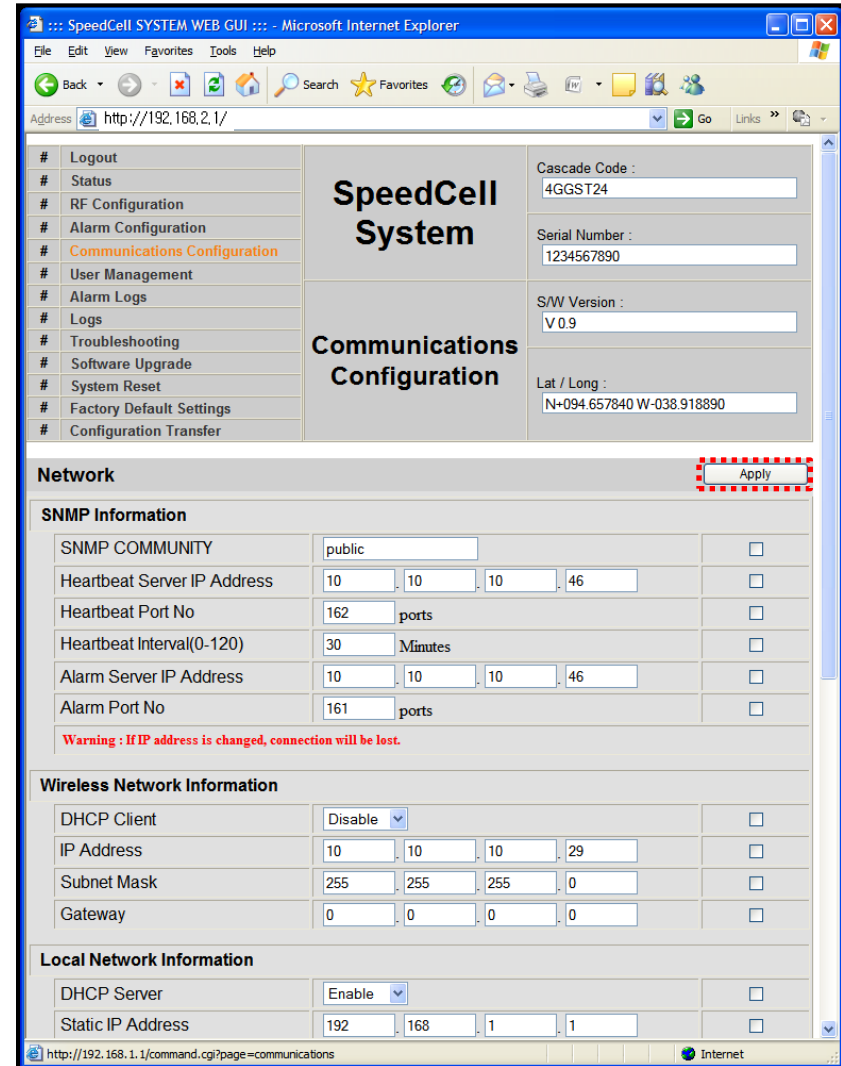

SpeedCell SYSTEM WEB GUI - Microsoft Internet Explorer

Address: http://192.168.2.1/

SpeedCell System

Communications Configuration

Cascade Code : 4GGST24

Serial Number : 1234567890

SW Version : V 0.9

Lat / Long : N+094.657840 W-038.918890

Network Apply

SNMP Information

SNMP COMMUNITY	public	<input type="checkbox"/>
Heartbeat Server IP Address	10 . 10 . 10 . 46	<input type="checkbox"/>
Heartbeat Port No	162 ports	<input type="checkbox"/>
Heartbeat Interval(0-120)	30 Minutes	<input type="checkbox"/>
Alarm Server IP Address	10 . 10 . 10 . 46	<input type="checkbox"/>
Alarm Port No	161 ports	<input type="checkbox"/>

Warning : If IP address is changed, connection will be lost.

Wireless Network Information

DHCP Client	Disable	<input type="checkbox"/>
IP Address	10 . 10 . 10 . 29	<input type="checkbox"/>
Subnet Mask	255 . 255 . 255 . 0	<input type="checkbox"/>
Gateway	0 . 0 . 0 . 0	<input type="checkbox"/>

Local Network Information

DHCP Server	Enable	<input type="checkbox"/>
Static IP Address	192 . 168 . 1 . 1	<input type="checkbox"/>

http://192.168.1.1/command.cgi?page=communications

Communication Configuration Menu

- On this page you can change various values related to IP network.
- Changes will not take effect until you click “Apply” button.
- In case that screen resolution is 1024 x 768, you may need to use scroll bar to view all.

In the line <Obtain IP address automatically> “Static” means connection using a fixed IP.

“DHCP” means connection using DHCP, where If “DHCP Client” is “ON”, then the repeater will run as a DHCP client.

If “DHCP Client” is “OFF”, then the repeater will get a Static IP.

“DHCP” means connection using DHCP, where If “DHCP Server” is “ON”, then the repeater will run as a DHCP server.

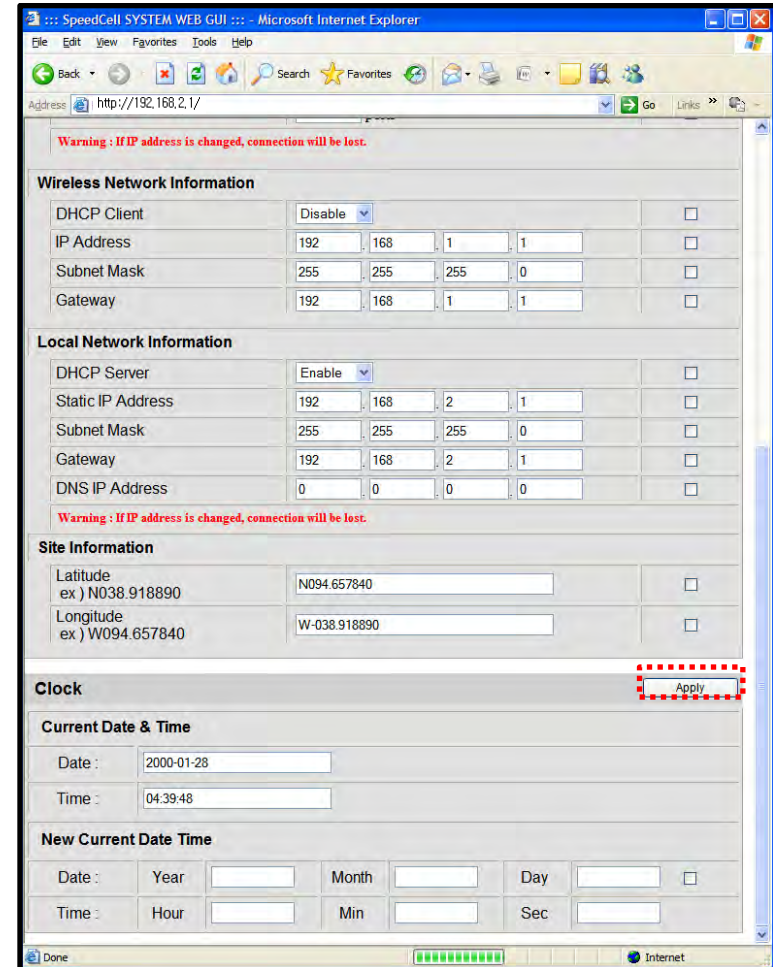

Warning: If IP address is changed, connection will be lost.

Wireless Network Information

DHCP Client	Disable	<input type="checkbox"/>
IP Address	192 168 1 1	<input type="checkbox"/>
Subnet Mask	255 255 255 0	<input type="checkbox"/>
Gateway	192 168 1 1	<input type="checkbox"/>

Local Network Information

DHCP Server	Enable	<input type="checkbox"/>
Static IP Address	192 168 2 1	<input type="checkbox"/>
Subnet Mask	255 255 255 0	<input type="checkbox"/>
Gateway	192 168 2 1	<input type="checkbox"/>
DNS IP Address	0 0 0 0	<input type="checkbox"/>

Warning: If IP address is changed, connection will be lost.

Site Information

Latitude ex) N038.918890	N094.657840	<input type="checkbox"/>
Longitude ex) W094.657840	W-038.918890	<input type="checkbox"/>

Clock Apply

Current Date & Time

Date :	2000-01-28
Time :	04:39:48

New Current Date Time

Date :	Year	Month	Day	<input type="checkbox"/>
Time :	Hour	Min	Sec	

User Management Menu

- Click on the „User Management’ link.
- On this page you can create and delete users, change passwords, and assign authorities to individual users.
- Read will only all the user to view information on the menu pages, but cannot make any changes.
- Read/Write Authority means that the user can view and change various values.
- Super User is very similar to an Administrator account...

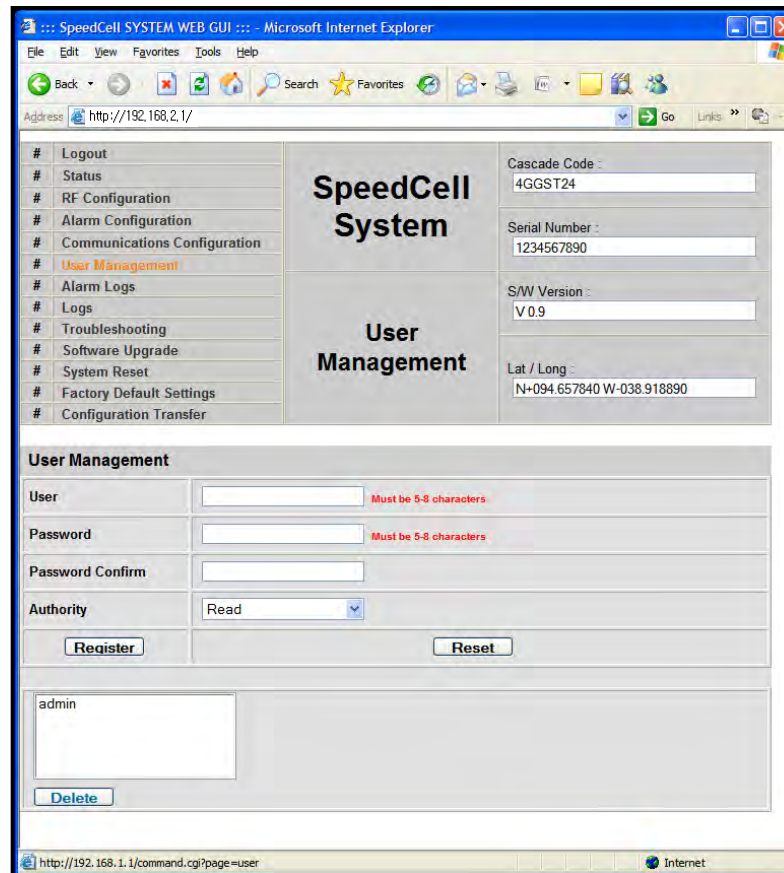

SpeedCell SYSTEM WEB GUI ::: - Microsoft Internet Explorer

Address: http://192.168.2.1/

SpeedCell System

User Management

Cascade Code :	4GGST24
Serial Number :	1234567890
S/W Version :	V 0.9
Lat / Long :	N+094.657840 W-038.918890

User Management

User: Must be 5-8 characters

Password: Must be 5-8 characters

Password Confirm:

Authority: Read

admin

http://192.168.1.1/command.cgi?page=user

CAUTION

 **DO NOT DELETE 'admin'.**

Alarm Logs

- Click on the Alarm Logs link.
- You can see a history of reported and reset Alarms.
When an alarm is reported, the name and time of the alarm is displayed along with its current status.

Red color means that the alarm is reported, and green color means that the alarm has returned to normal status.

- After an Alarm condition lasts for the “Delay Alarm Reporting Minutes” set in RF Configuration page, the Alarm will be reported.

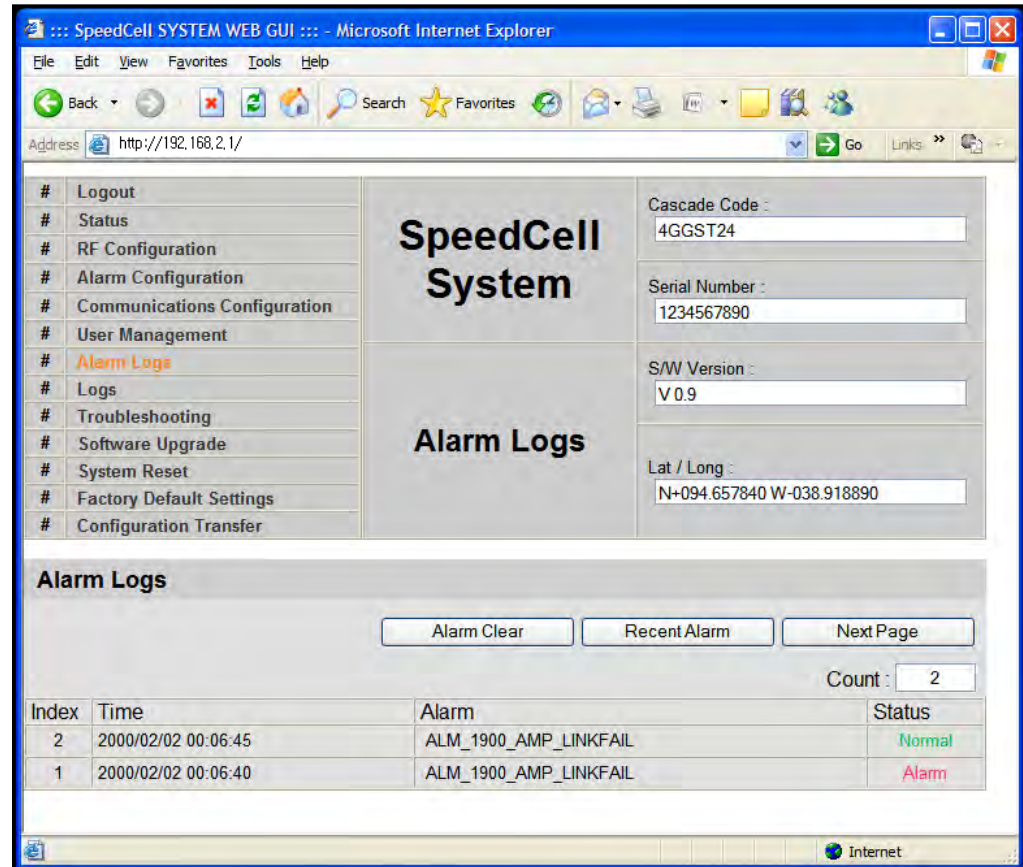

Index	Time	Alarm	Status
2	2000/02/02 00:06:45	ALM_1900_AMP_LINKFAIL	Normal
1	2000/02/02 00:06:40	ALM_1900_AMP_LINKFAIL	Alarm

Logs

- Click on the Logs link.
- You can see Logs regarding Web UI operation.
Logs will maintain a history of up to 30 operations.
- In case that screen resolution is 1024 x 768, you may need to use scroll bar to view all.

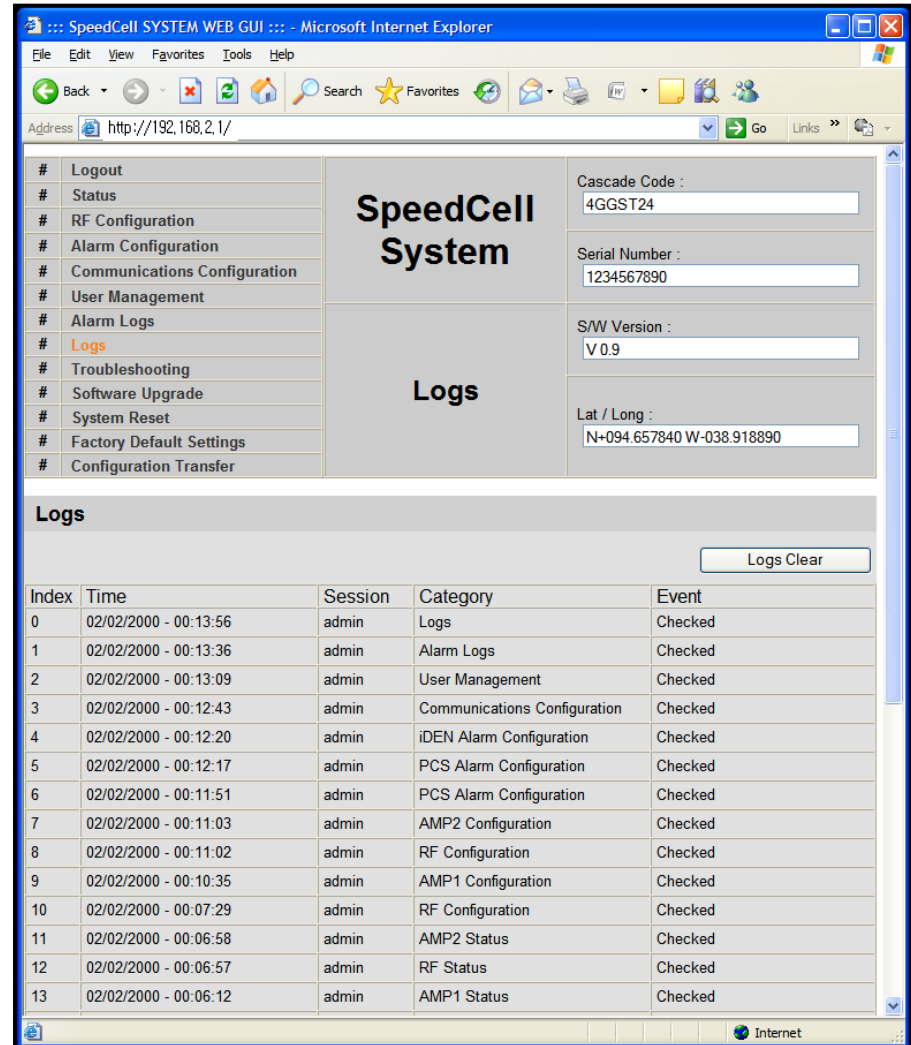

The screenshot shows the SpeedCell SYSTEM WEB GUI interface. The browser window title is "SpeedCell SYSTEM WEB GUI :: Microsoft Internet Explorer". The address bar displays "http://192.168.2.1/". The page layout includes a navigation menu on the left, a central header area, and a main content area.

SpeedCell System

Logs

Navigation Menu (Left):

- # Logout
- # Status
- # RF Configuration
- # Alarm Configuration
- # Communications Configuration
- # User Management
- # Alarm Logs
- # **Logs**
- # Troubleshooting
- # Software Upgrade
- # System Reset
- # Factory Default Settings
- # Configuration Transfer

System Information (Right):

- Cascade Code : 4GGST24
- Serial Number : 1234567890
- S/W Version : V 0.9
- Lat / Long : N+094.657840 W-038.918890

Logs

Logs Clear

Index	Time	Session	Category	Event
0	02/02/2000 - 00:13:56	admin	Logs	Checked
1	02/02/2000 - 00:13:36	admin	Alarm Logs	Checked
2	02/02/2000 - 00:13:09	admin	User Management	Checked
3	02/02/2000 - 00:12:43	admin	Communications Configuration	Checked
4	02/02/2000 - 00:12:20	admin	iDEN Alarm Configuration	Checked
5	02/02/2000 - 00:12:17	admin	PCS Alarm Configuration	Checked
6	02/02/2000 - 00:11:51	admin	PCS Alarm Configuration	Checked
7	02/02/2000 - 00:11:03	admin	AMP2 Configuration	Checked
8	02/02/2000 - 00:11:02	admin	RF Configuration	Checked
9	02/02/2000 - 00:10:35	admin	AMP1 Configuration	Checked
10	02/02/2000 - 00:07:29	admin	RF Configuration	Checked
11	02/02/2000 - 00:06:58	admin	AMP2 Status	Checked
12	02/02/2000 - 00:06:57	admin	RF Status	Checked
13	02/02/2000 - 00:06:12	admin	AMP1 Status	Checked

Logs

Continue of Logs page.

- In case that screen resolution is 1024 x 768, you may need to use scroll bar to view all.

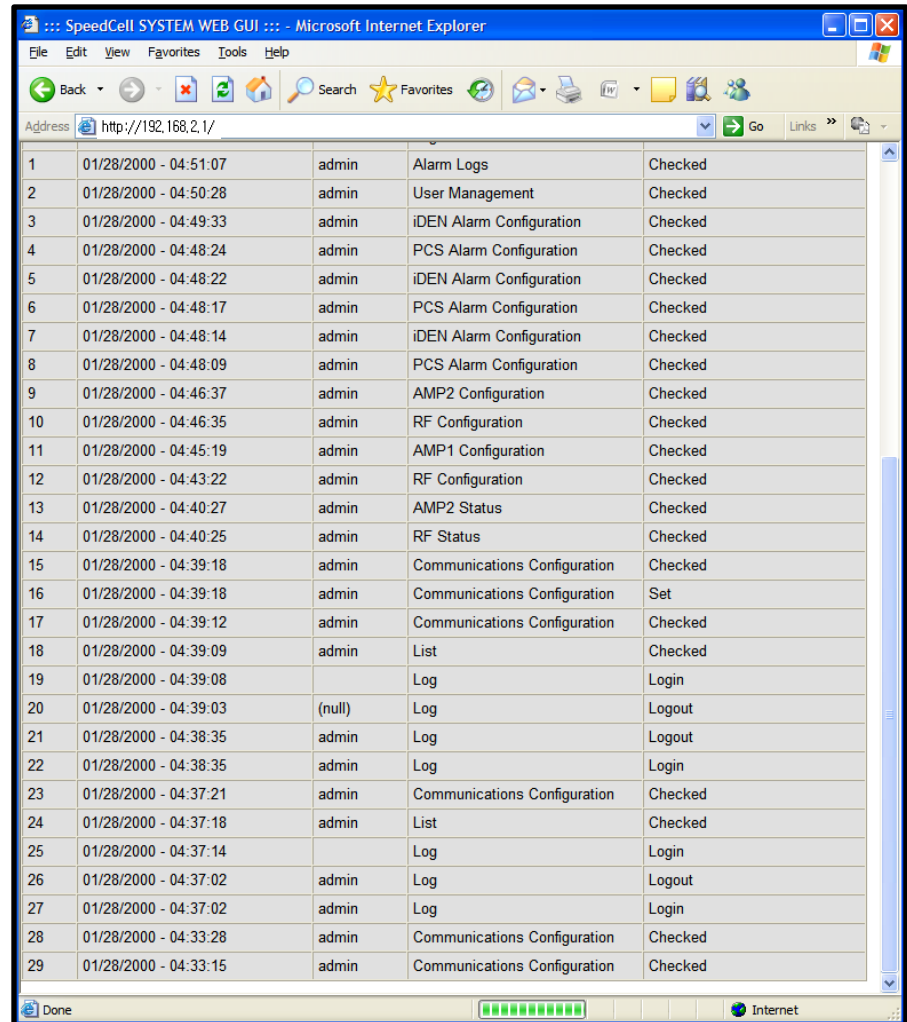

1	01/28/2000 - 04:51:07	admin	Alarm Logs	Checked
2	01/28/2000 - 04:50:28	admin	User Management	Checked
3	01/28/2000 - 04:49:33	admin	iDEN Alarm Configuration	Checked
4	01/28/2000 - 04:48:24	admin	PCS Alarm Configuration	Checked
5	01/28/2000 - 04:48:22	admin	iDEN Alarm Configuration	Checked
6	01/28/2000 - 04:48:17	admin	PCS Alarm Configuration	Checked
7	01/28/2000 - 04:48:14	admin	iDEN Alarm Configuration	Checked
8	01/28/2000 - 04:48:09	admin	PCS Alarm Configuration	Checked
9	01/28/2000 - 04:46:37	admin	AMP2 Configuration	Checked
10	01/28/2000 - 04:46:35	admin	RF Configuration	Checked
11	01/28/2000 - 04:45:19	admin	AMP1 Configuration	Checked
12	01/28/2000 - 04:43:22	admin	RF Configuration	Checked
13	01/28/2000 - 04:40:27	admin	AMP2 Status	Checked
14	01/28/2000 - 04:40:25	admin	RF Status	Checked
15	01/28/2000 - 04:39:18	admin	Communications Configuration	Checked
16	01/28/2000 - 04:39:18	admin	Communications Configuration	Set
17	01/28/2000 - 04:39:12	admin	Communications Configuration	Checked
18	01/28/2000 - 04:39:09	admin	List	Checked
19	01/28/2000 - 04:39:08		Log	Login
20	01/28/2000 - 04:39:03	(null)	Log	Logout
21	01/28/2000 - 04:38:35	admin	Log	Logout
22	01/28/2000 - 04:38:35	admin	Log	Login
23	01/28/2000 - 04:37:21	admin	Communications Configuration	Checked
24	01/28/2000 - 04:37:18	admin	List	Checked
25	01/28/2000 - 04:37:14		Log	Login
26	01/28/2000 - 04:37:02	admin	Log	Logout
27	01/28/2000 - 04:37:02	admin	Log	Login
28	01/28/2000 - 04:33:28	admin	Communications Configuration	Checked
29	01/28/2000 - 04:33:15	admin	Communications Configuration	Checked

Troubleshooting

- Click on the Troubleshooting link.
- You can refer to this page for GST's technical support.

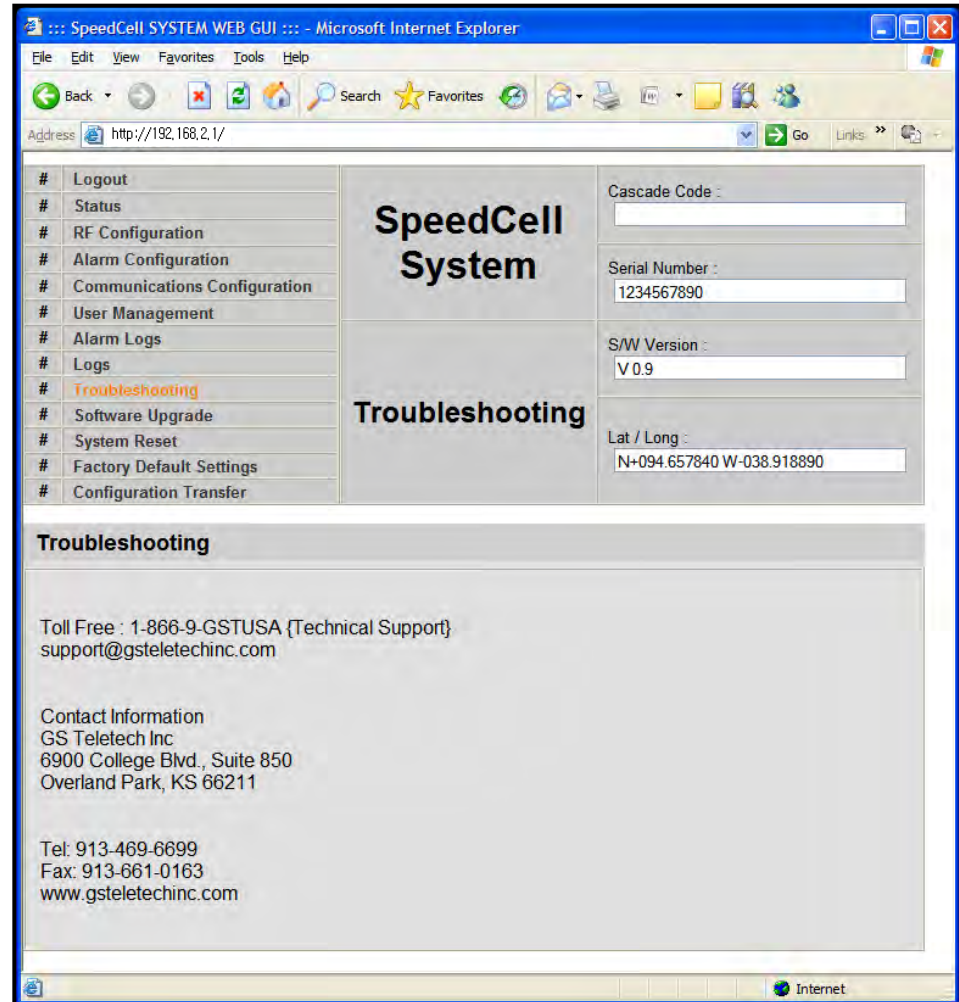

SpeedCell SYSTEM WEB GUI - Microsoft Internet Explorer

Address: <http://192.168.2.1/>

# Logout	SpeedCell System	Cascade Code :	<input type="text"/>
# Status		Serial Number :	<input type="text" value="1234567890"/>
# RF Configuration		S/W Version :	<input type="text" value="V 0.9"/>
# Alarm Configuration		Lat / Long :	<input type="text" value="N+094.657840 W-038.918890"/>
# Communications Configuration			
# User Management			
# Alarm Logs			
# Logs			
# Troubleshooting			
# Software Upgrade			
# System Reset			
# Factory Default Settings			
# Configuration Transfer			

Troubleshooting

Toll Free : 1-866-9-GSTUSA {Technical Support}
support@gsteletechinc.com

Contact Information
GS Teletech Inc
6900 College Blvd., Suite 850
Overland Park, KS 66211

Tel: 913-469-6699
Fax: 913-661-0163
www.gsteletechinc.com

Software Upgrade

- Click on the Remote Software Upgrade link.
- In case that software upgrade is needed, you should use this page.
- Click Browse button to select the file to upgrade from the laptop.

- Choose the file to upgrade provided by GST. After you choose the file, you should click “upload” to send the file from your laptop to the Repeater.
- Provided files are three, need to download each of them.
 - The files are,
 - ① SC_SNMP.MCU
 - ② SC_AMP.AMP
 - ③ SC_DFM.SDR
SC_DFM.SDS

CAUTION



Be careful not to unplug the crossover Ethernet cable during software upgrade.

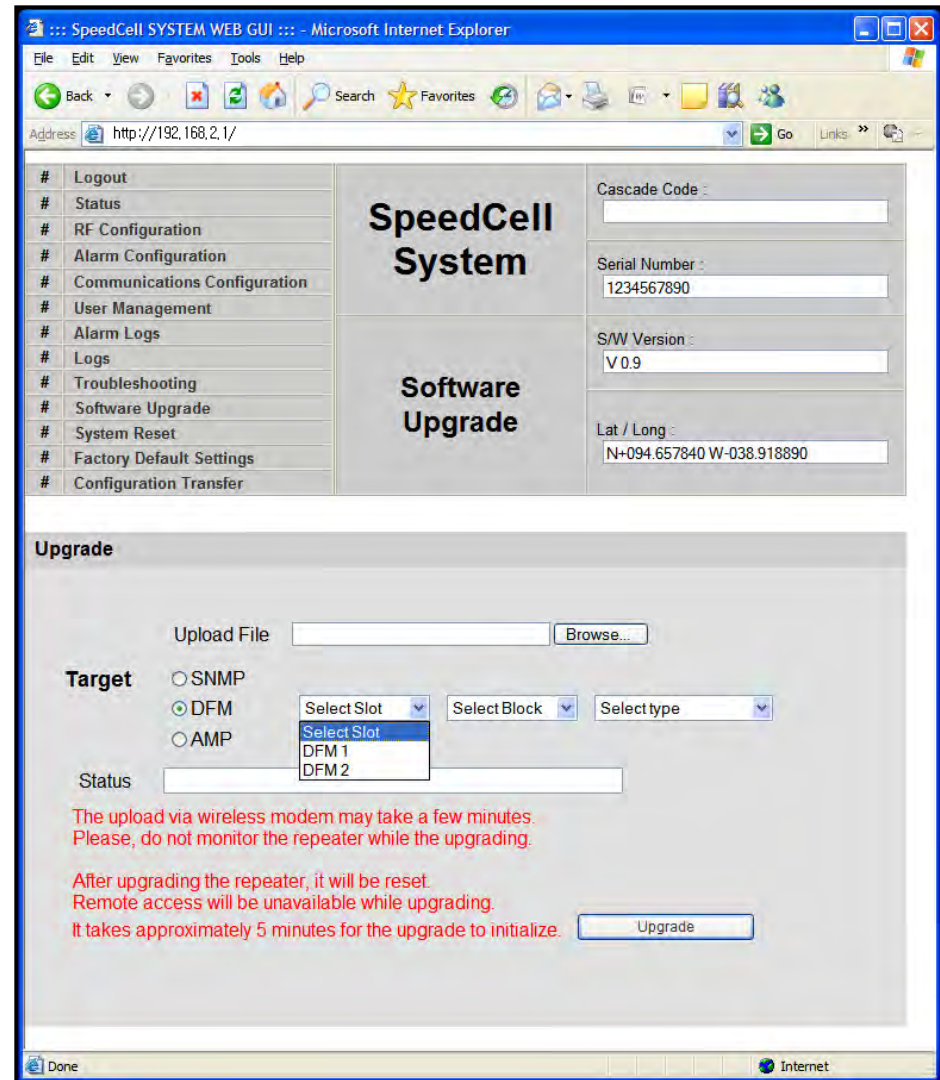

SpeedCell SYSTEM WEB GUI ::: - Microsoft Internet Explorer

Address: http://192.168.2.1/

SpeedCell System

Software Upgrade

Upgrade

Upload File: Browse...

Target:

- SNMP
- DFM
- AMP

Select Slot: Select Block: Select type:

Status:

The upload via wireless modem may take a few minutes. Please, do not monitor the repeater while the upgrading.

After upgrading the repeater, it will be reset. Remote access will be unavailable while upgrading. It takes approximately 5 minutes for the upgrade to initialize.

Upgrade

Software Upgrade

- After uploading is finished, verify that the File Name and the File Size is correct, then click „Upgrade System’ button.
The lights on the repeater will be blinking and change color during upgrade which will take about two minutes for the upgrade to initialize.
The lights will go back to normal when upgrade is done.

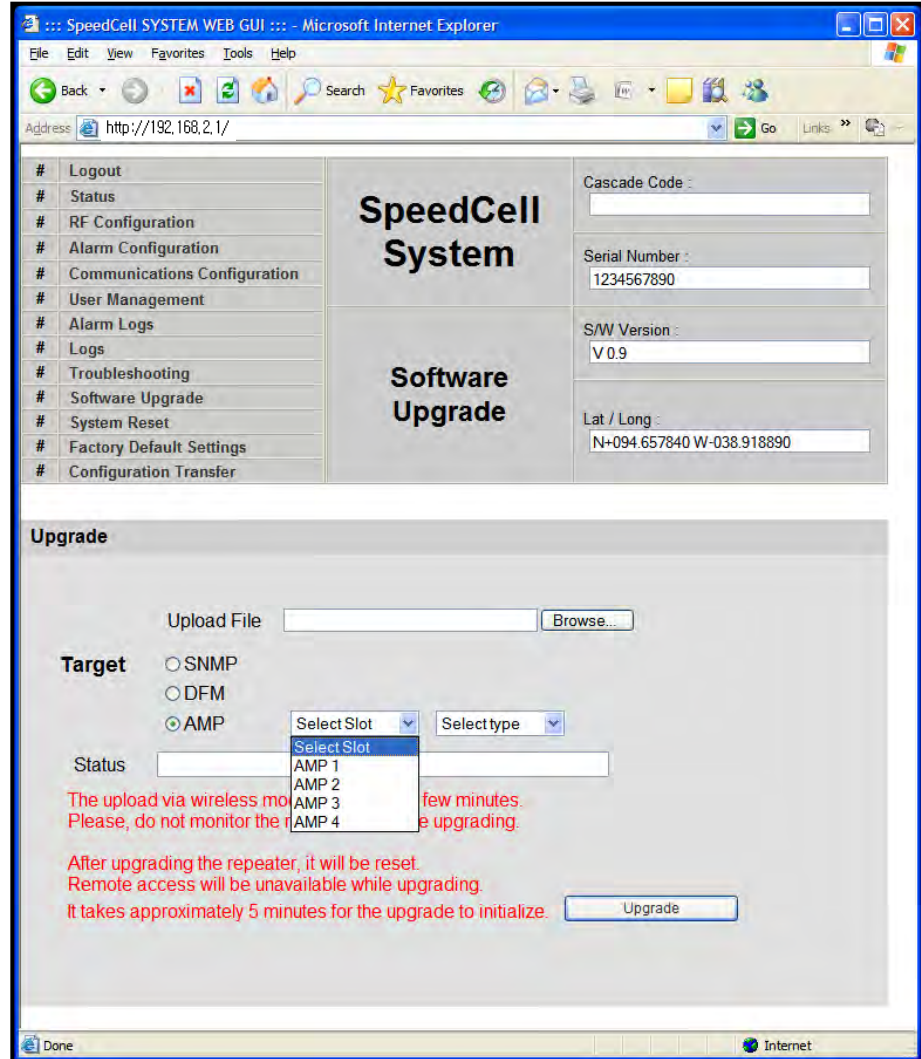

SpeedCell SYSTEM WEB GUI :: - Microsoft Internet Explorer

Address http://192.168.2.1/

Logout
Status
RF Configuration
Alarm Configuration
Communications Configuration
User Management
Alarm Logs
Logs
Troubleshooting
Software Upgrade
System Reset
Factory Default Settings
Configuration Transfer

SpeedCell System

Cascade Code :
Serial Number : 1234567890
S/W Version : V 0.9
Lat / Long : N+094.657840 W-038.918890

Software Upgrade

Upgrade

Upload File

Target
 SNMP
 DFM
 AMP

Select Slot Select type

Status

The upload via wireless mode will take a few minutes.
Please, do not monitor the repeater while upgrading.

After upgrading the repeater, it will be reset.
Remote access will be unavailable while upgrading.
It takes approximately 5 minutes for the upgrade to initialize.

Done Internet

System Reset

- Click 'No' to return to the 'List' menu.
- Click 'Yes' to reset the repeater via a soft-boot. This will not change any of the current settings

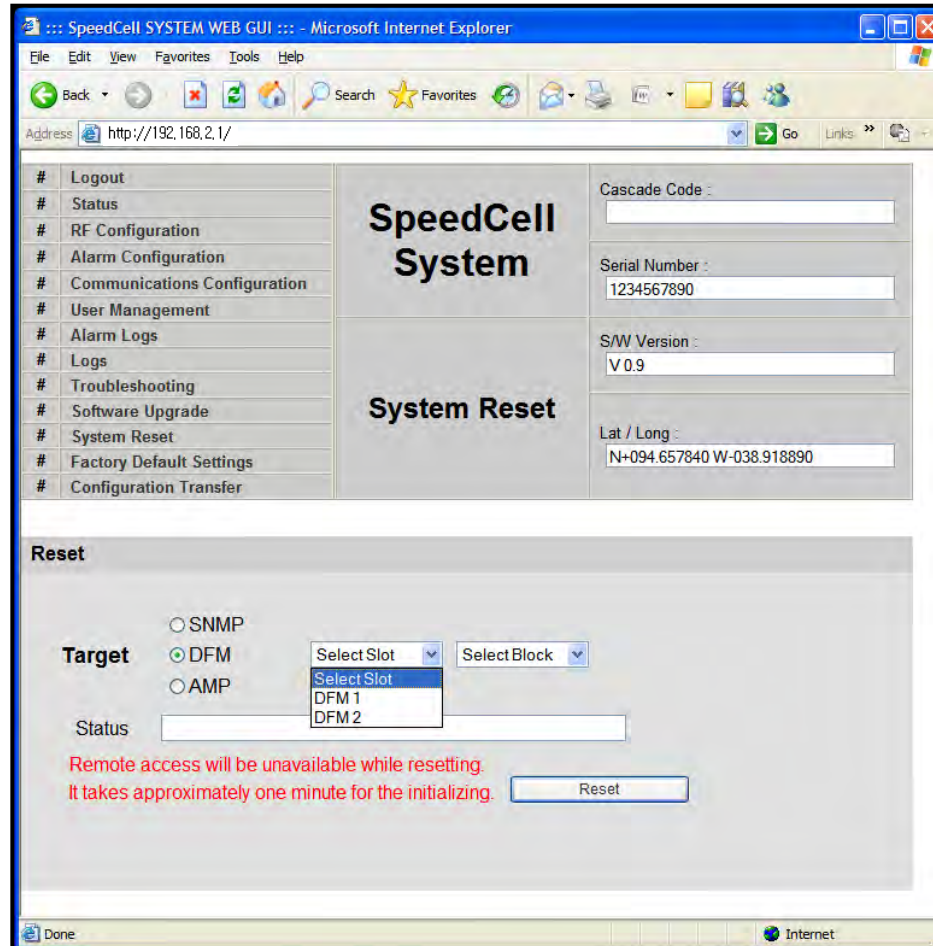

System Reset

- Click 'No' to return to the 'List' menu.
- Click 'Yes' to reset the repeater via a soft-boot. This will not change any of the current settings.

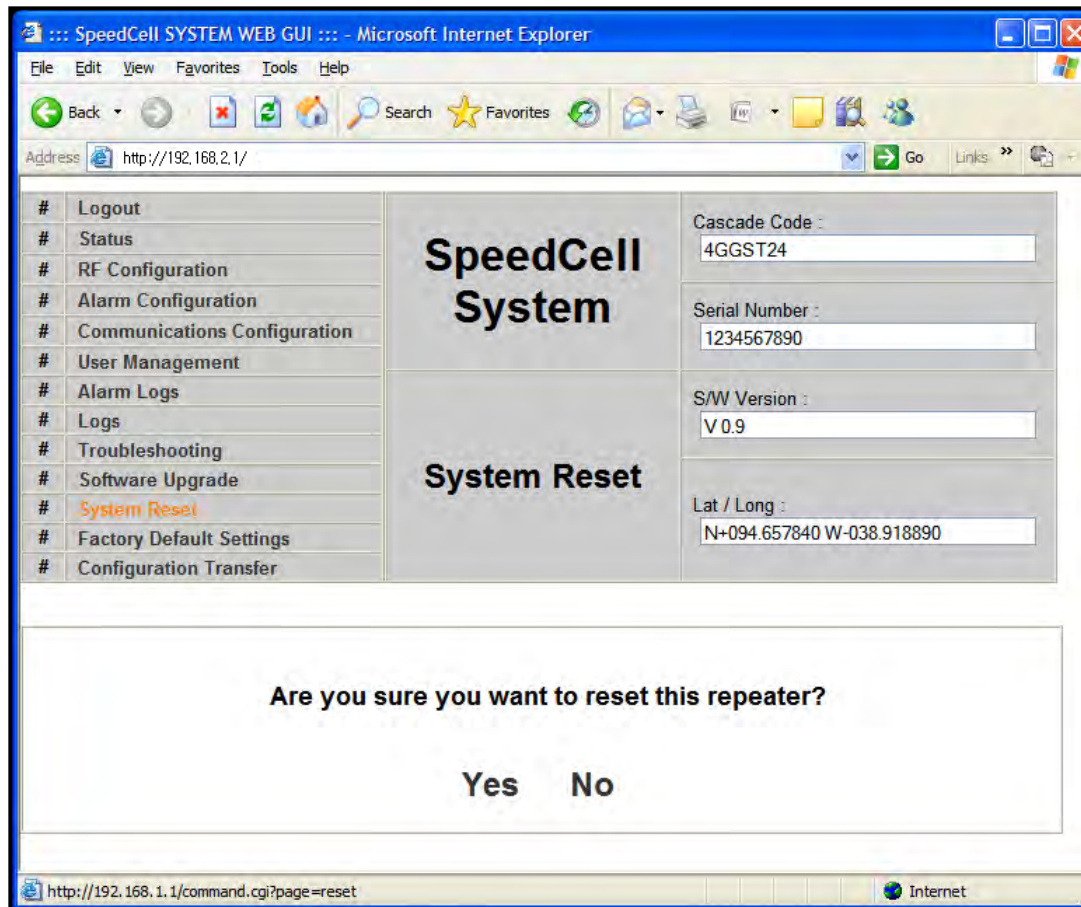

Factory Default Settings

- Choose type of configuration to be restored to factory default settings.

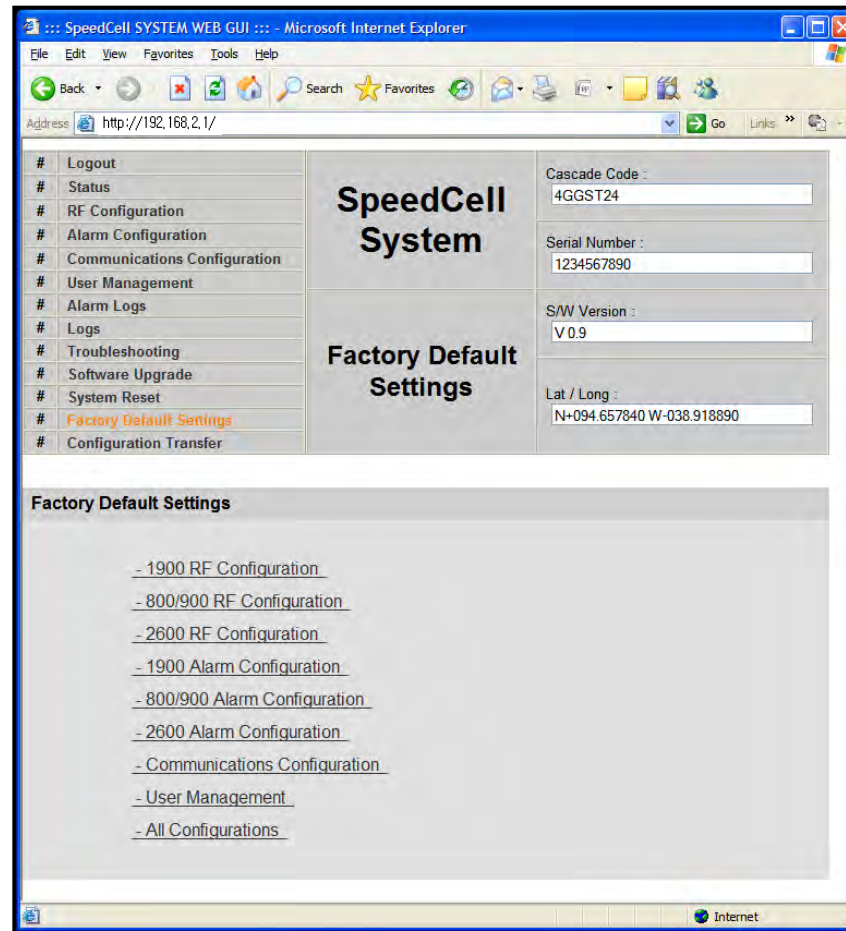

SpeedCell SYSTEM WEB GUI - Microsoft Internet Explorer

Address: http://192.168.2.1/

# Logout	SpeedCell System	Cascade Code : 4GGST24
# Status		Serial Number : 1234567890
# RF Configuration		S/W Version : V 0.9
# Alarm Configuration		Lat / Long : N+094.657840 W-038.918890
# Communications Configuration		
# User Management		
# Alarm Logs		
# Logs		
# Troubleshooting		
# Software Upgrade		
# System Reset		
# Factory Default Settings		
# Configuration Transfer		

Factory Default Settings

- [1900 RF Configuration](#)
- [800/900 RF Configuration](#)
- [2600 RF Configuration](#)
- [1900 Alarm Configuration](#)
- [800/900 Alarm Configuration](#)
- [2600 Alarm Configuration](#)
- [Communications Configuration](#)
- [User Management](#)
- [All Configurations](#)

Factory Default Settings

- This function will allow you to roll back to factory default settings.

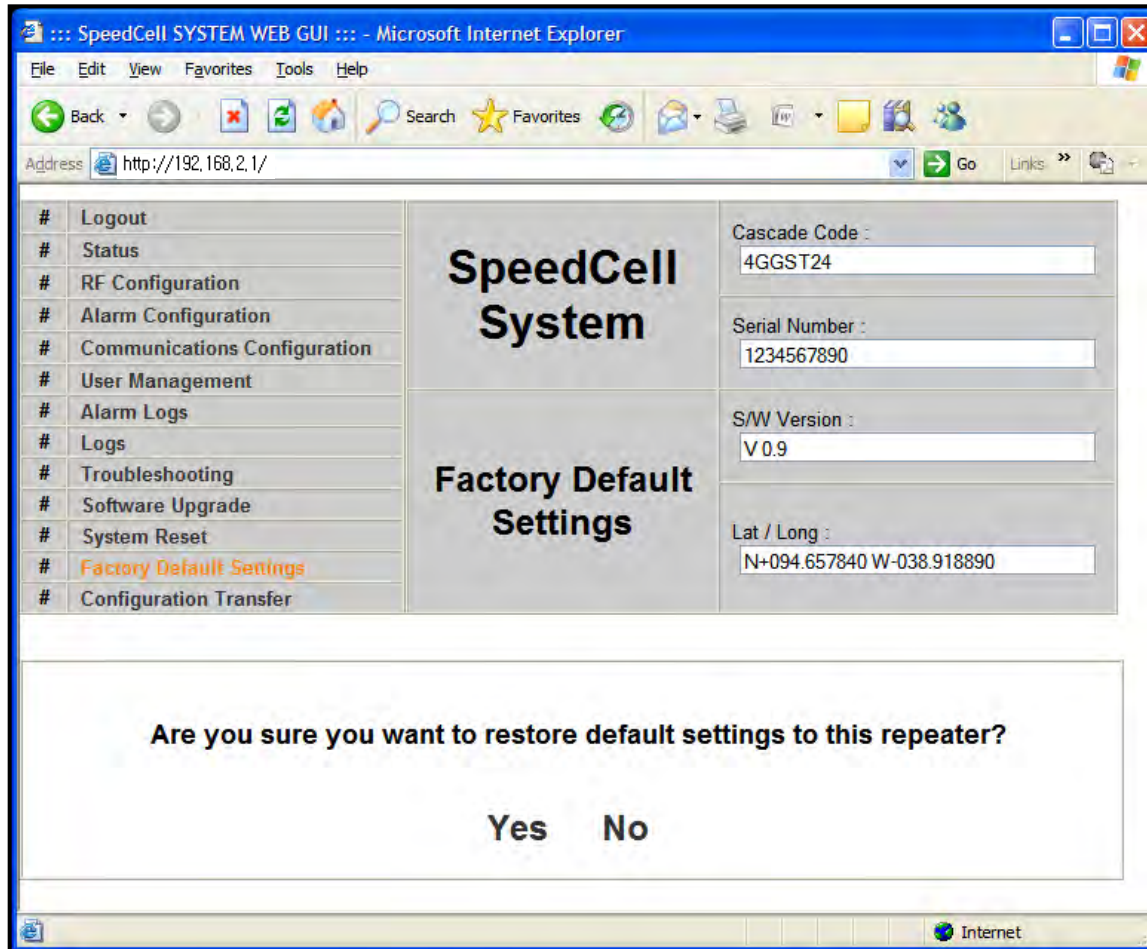

SpeedCell SYSTEM WEB GUI :: - Microsoft Internet Explorer

Address <http://192.168.2.1/>

# Logout	SpeedCell System	Cascade Code : <input type="text" value="4GGST24"/>
# Status		Serial Number : <input type="text" value="1234567890"/>
# RF Configuration		S/W Version : <input type="text" value="V 0.9"/>
# Alarm Configuration		Lat / Long : <input type="text" value="N+094.657840 W-038.918890"/>
# Communications Configuration		
# User Management		
# Alarm Logs		
# Logs		
# Troubleshooting		
# Software Upgrade		
# System Reset		
# Factory Default Settings		
# Configuration Transfer		

Are you sure you want to restore default settings to this repeater?

Yes No

Internet

Configuration Transfer

- Configuration Transfer function is for downloading and uploading set values of the repeater.

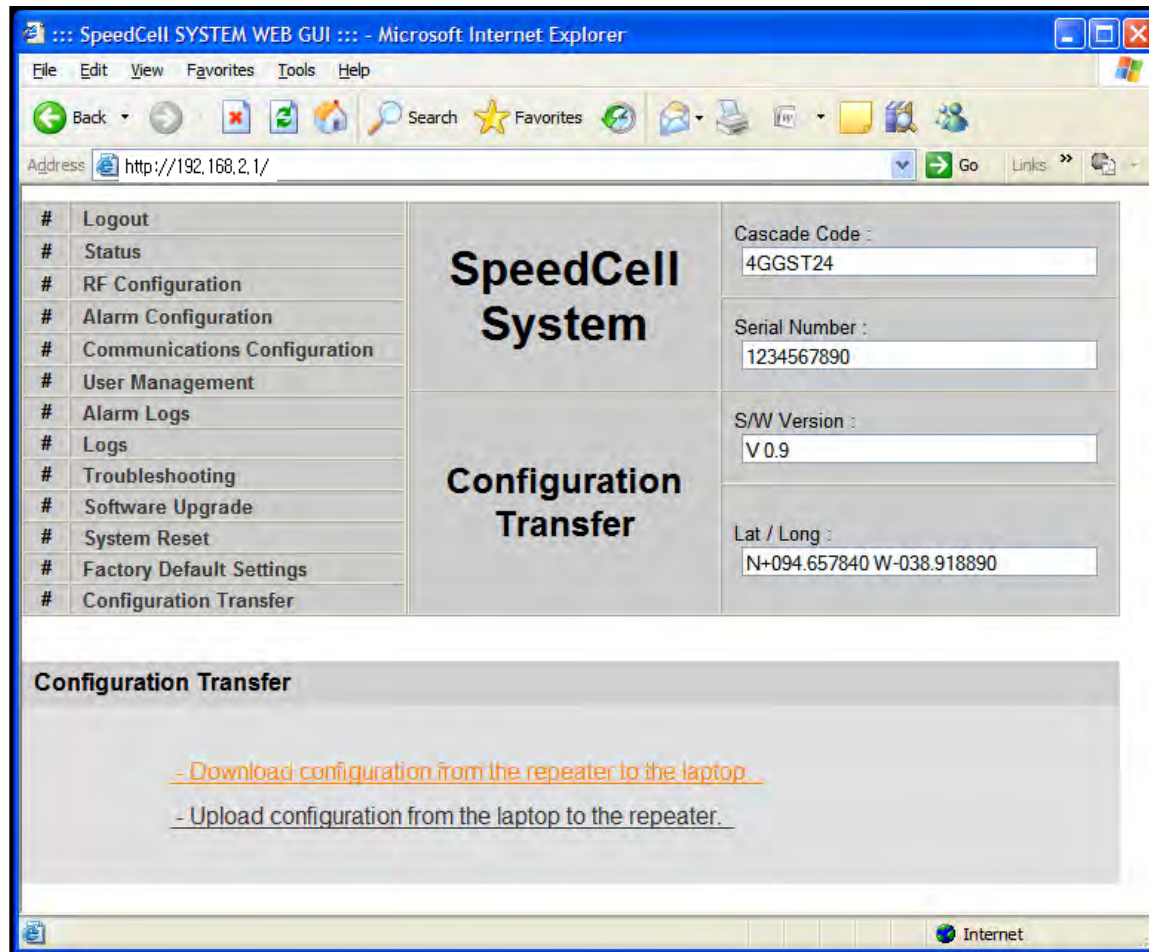

SpeedCell SYSTEM WEB GUI - Microsoft Internet Explorer

Address: http://192.168.2.1/

# Logout	SpeedCell System	Cascade Code :	<input type="text" value="4GGST24"/>
# Status		Serial Number :	<input type="text" value="1234567890"/>
# RF Configuration		S/W Version :	<input type="text" value="V 0.9"/>
# Alarm Configuration		Lat / Long :	<input type="text" value="N+094.657840 W-038.918890"/>
# Communications Configuration			
# User Management			
# Alarm Logs			
# Logs			
# Troubleshooting			
# Software Upgrade			
# System Reset			
# Factory Default Settings			
# Configuration Transfer			

Configuration Transfer

- Download configuration from the repeater to the laptop.

- Upload configuration from the laptop to the repeater.

Configuration Transfer: Download

- Configuration Transfer Download Display.

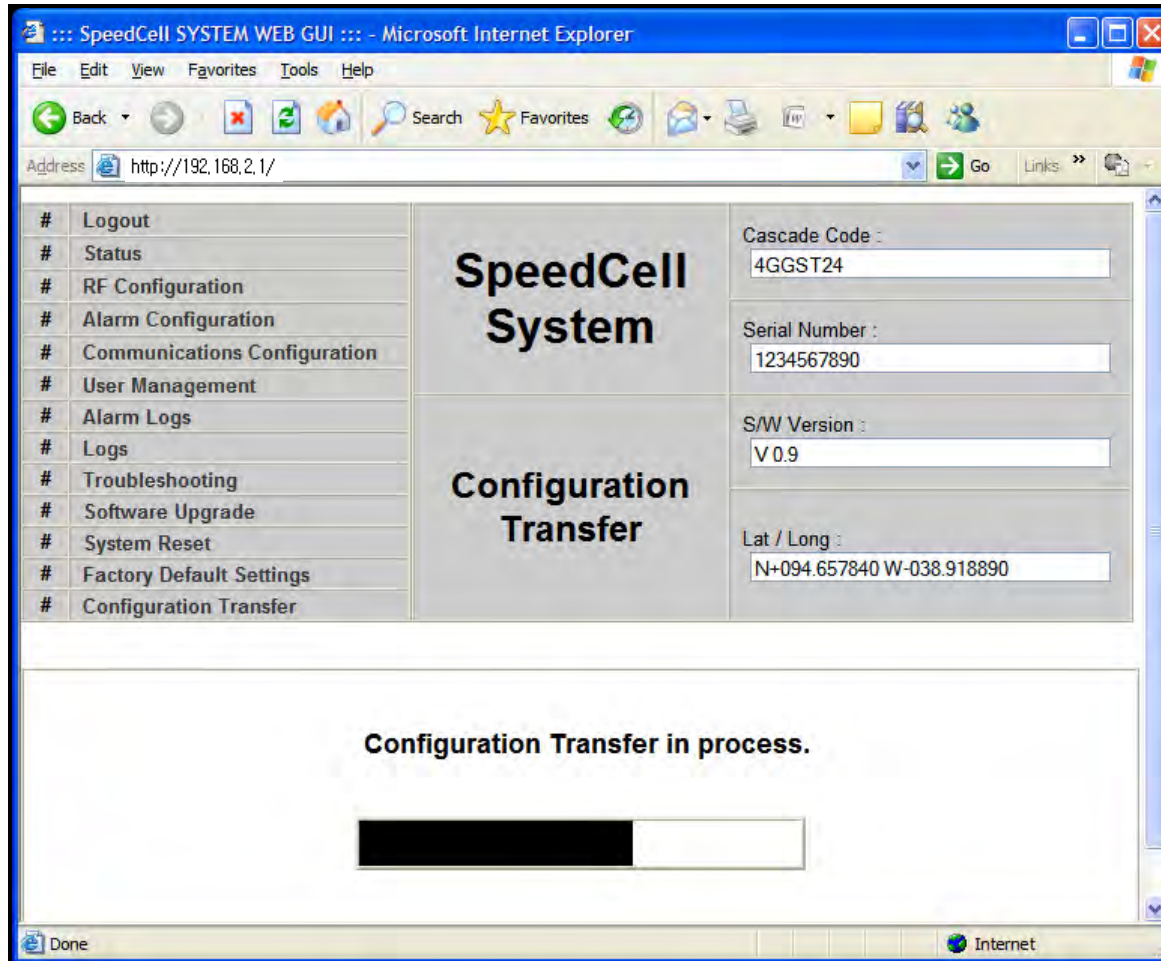

SpeedCell SYSTEM WEB GUI ::: - Microsoft Internet Explorer

File Edit View Favorites Tools Help

Back Forward Stop Refresh Home Search Favorites

Address http://192.168.2.1/ Go Links

# Logout	SpeedCell System	Cascade Code :
# Status		<input type="text" value="4GGST24"/>
# RF Configuration		Serial Number :
# Alarm Configuration		<input type="text" value="1234567890"/>
# Communications Configuration		S/W Version :
# User Management		<input type="text" value="V 0.9"/>
# Alarm Logs		Lat / Long :
# Logs		<input type="text" value="N+094.657840 W-038.918890"/>
# Troubleshooting		
# Software Upgrade		
# System Reset		
# Factory Default Settings		
# Configuration Transfer		

Configuration Transfer

Configuration Transfer in process.

Done Internet

Configuration Transfer

- Downloading process of set values.

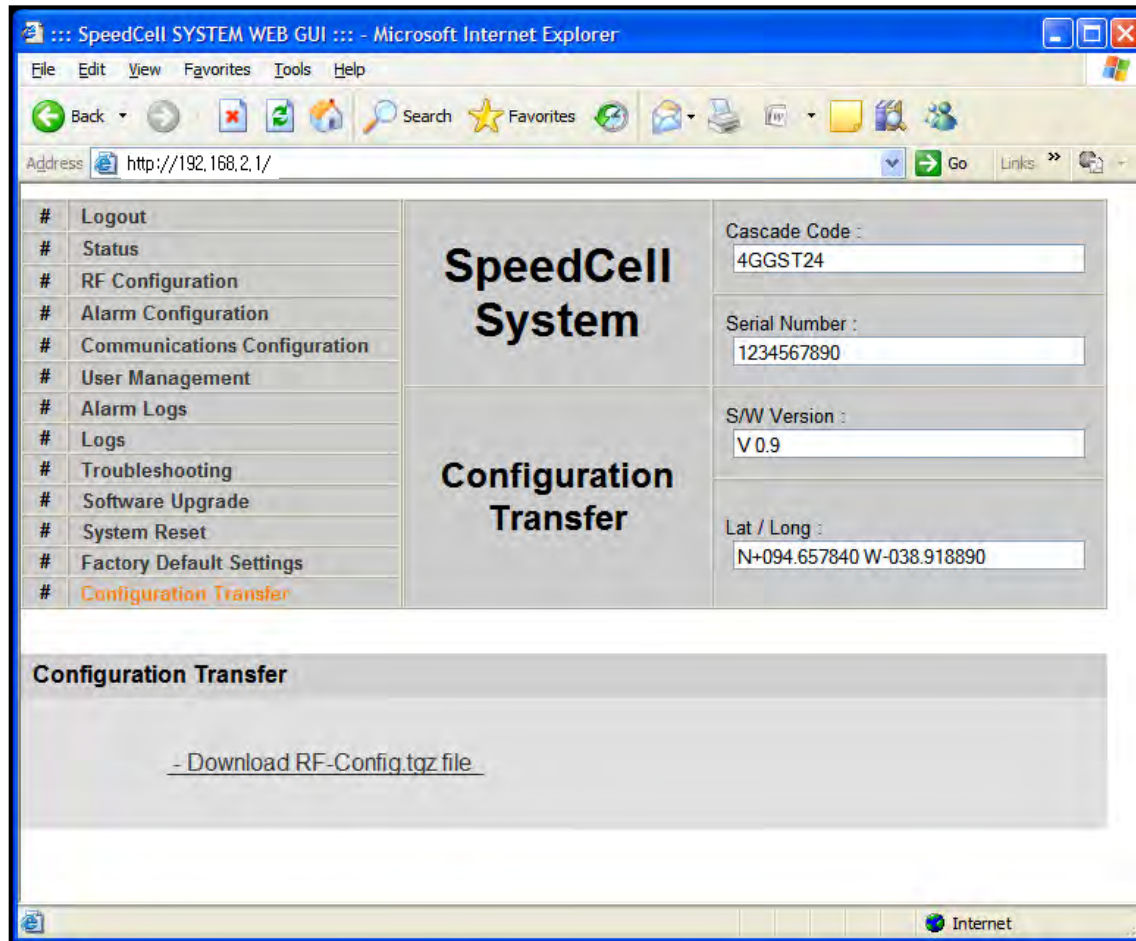

SpeedCell SYSTEM WEB GUI ::: - Microsoft Internet Explorer

Address: http://192.168.2.1/

# Logout	SpeedCell System	Cascade Code :	4GGST24
# Status		Serial Number :	1234567890
# RF Configuration		S/W Version :	V 0.9
# Alarm Configuration		Lat / Long :	N+094.657840 W-038.918890
# Communications Configuration			
# User Management			
# Alarm Logs			
# Logs			
# Troubleshooting			
# Software Upgrade			
# System Reset			
# Factory Default Settings			
# Configuration Transfer			

Configuration Transfer

[- Download RF-Config.tgz file](#)

Configuration Transfer: Upload

- Uploading process of set values.
- Verify correct file is selected and click „Configuration Transfer’.

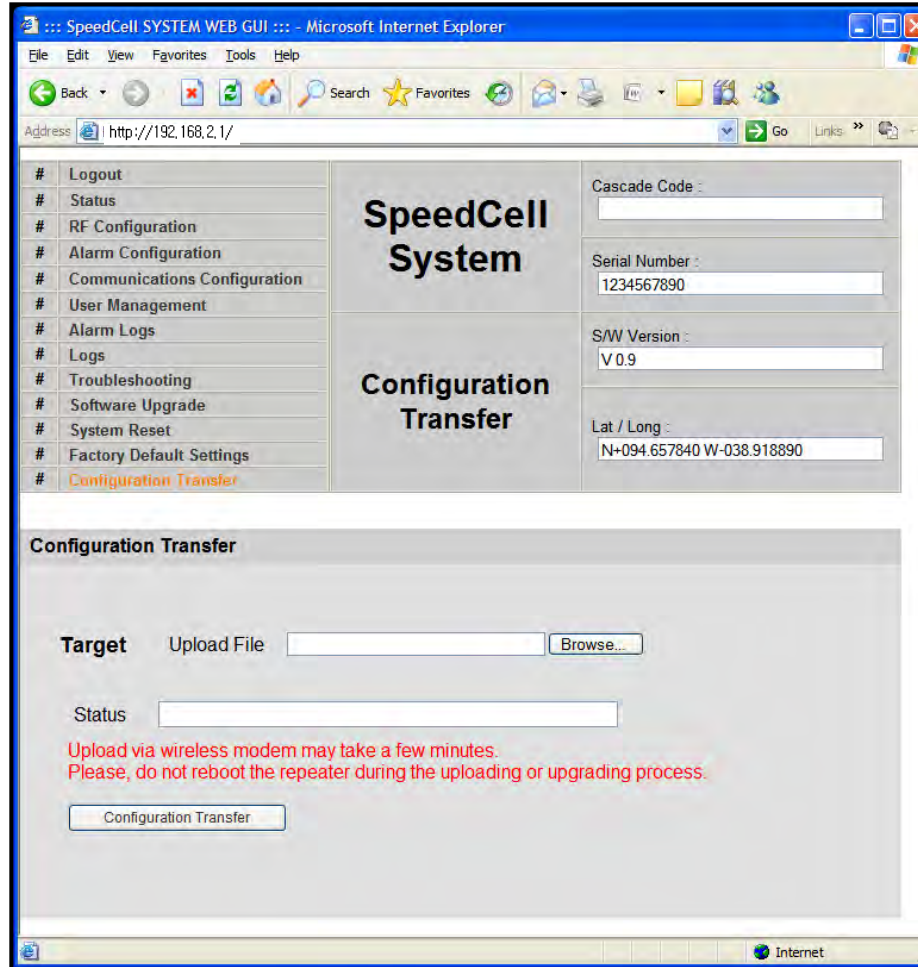

SpeedCell SYSTEM WEB GUI ::: - Microsoft Internet Explorer

Address

SpeedCell System

Configuration Transfer

Cascade Code :

Serial Number :

S/W Version :

Lat / Long :

Configuration Transfer

Target Upload File

Status

Upload via wireless modem may take a few minutes.
Please, do not reboot the repeater during the uploading or upgrading process.

Command Line Interface (CLI)

- In case that you cannot reach Web UI, you should use CLI.
You should connect the equipment's CLI port to your laptop's serial port using RS-232 cable.
In case that your laptop does not have a serial port, you may need to use USB to Serial conversion cable.
- To open HyperTerminal, click "Start", then "Accessories", then "Communications", then "HyperTerminal".

CAUTION

-  *RS-232 cable or USB to Serial conversion cable is not provided with the equipment.
After connection, you can access CLI using HyperTerminal.*

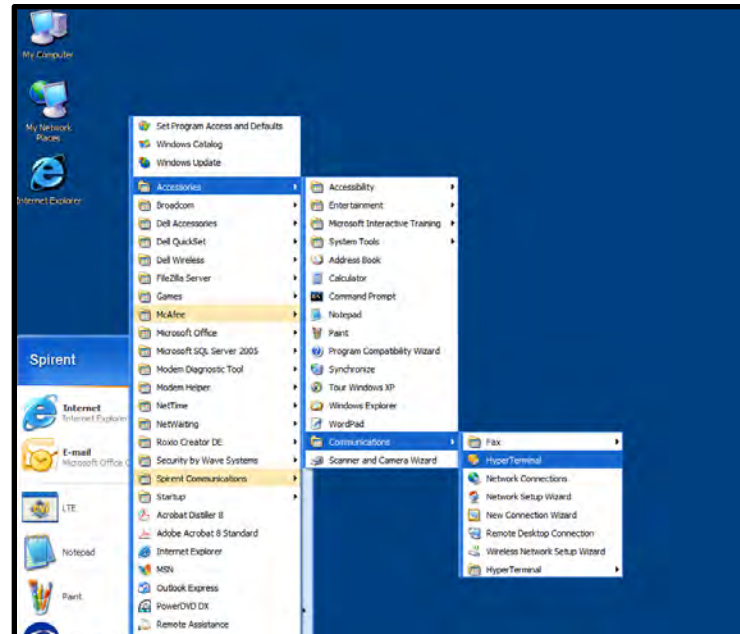

CLI

- To verify and/or change port number, open “Control Panel”, then “System”, then “Hardware Tab”, then “Device Manager”. Double click “Ports”, then double click “Serial Cable” then click “Port Settings” tab, click “Advanced”, in the COM Port drop down menu, select “COM 1”, click “OK”.
- After verification of port number, open HyperTerminal.
- Enter CLI.
- Click “OK”.

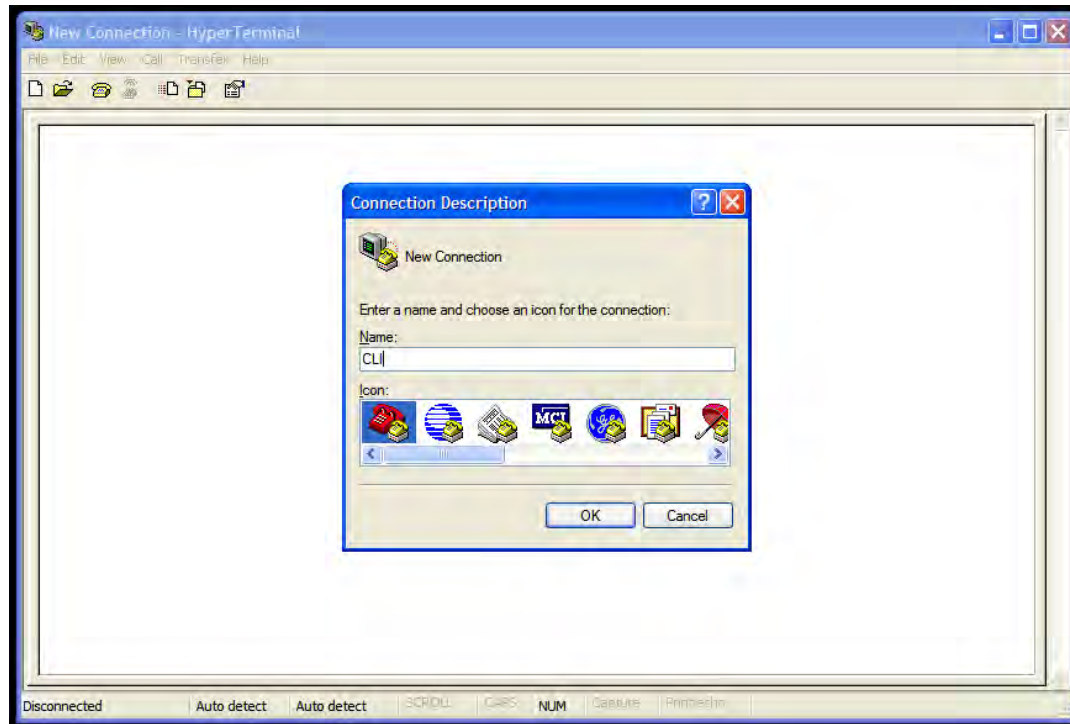

CLI

- In the “Connect using” drop-down menu, select “COM1”.
- Click “OK”.

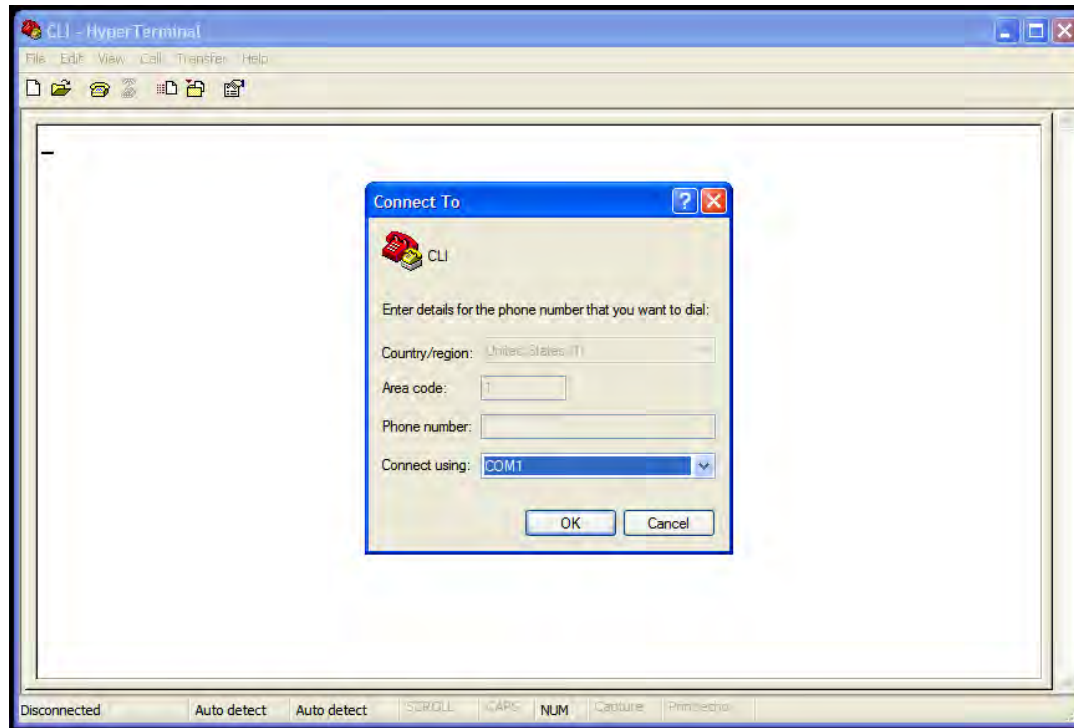

CLI

- “Bit per second” drop down menu, select “115200”.
- “Flow control” drop down menu, select “None”.
- Click “Apply”.
- Click “OK”.

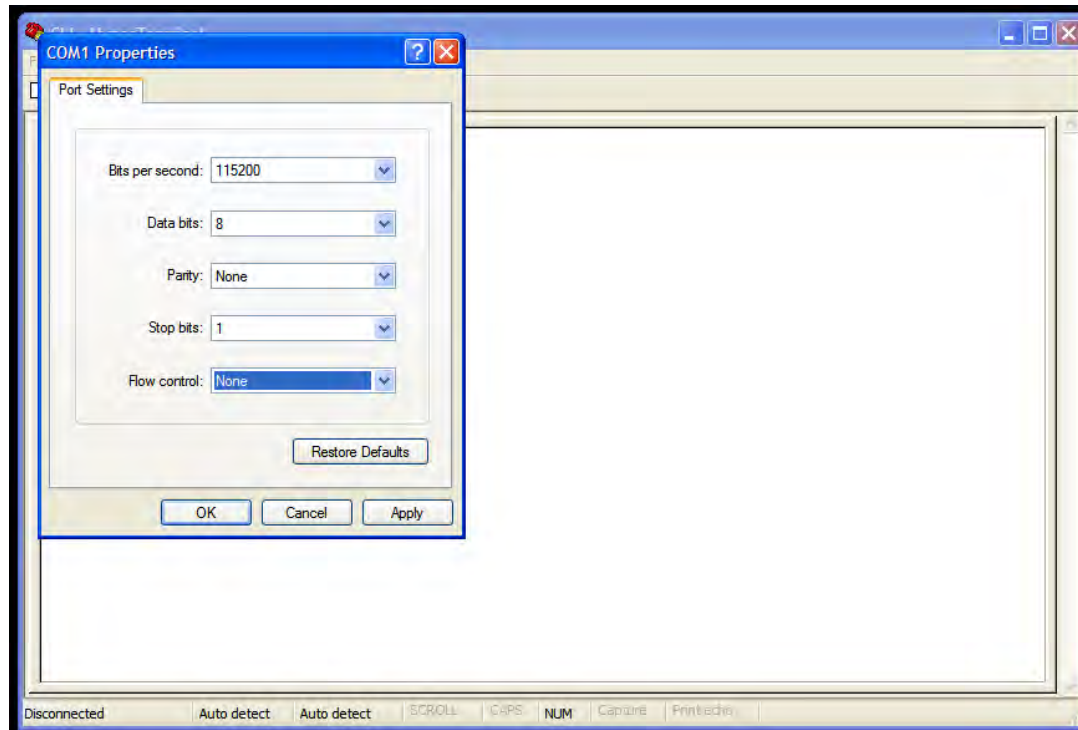

CLI

- Click “File”, choose “Properties”

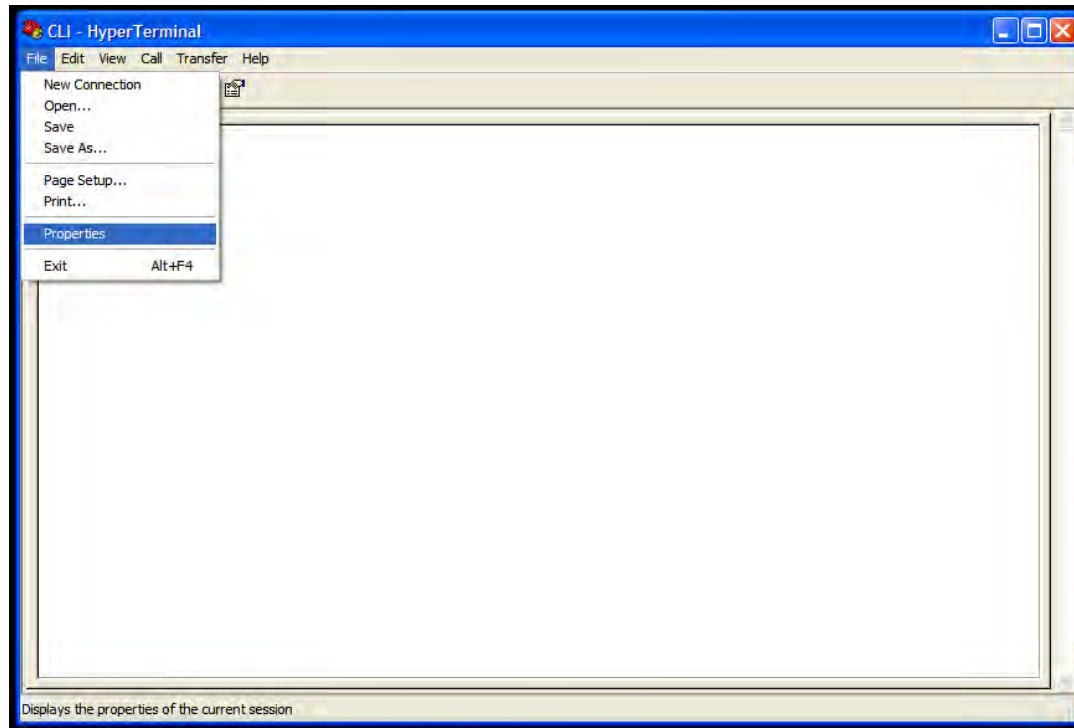

CLI

- On „Settings’ tab.
- „Emulation’ drop down menu, select „VT100’.
- Click „OK’.

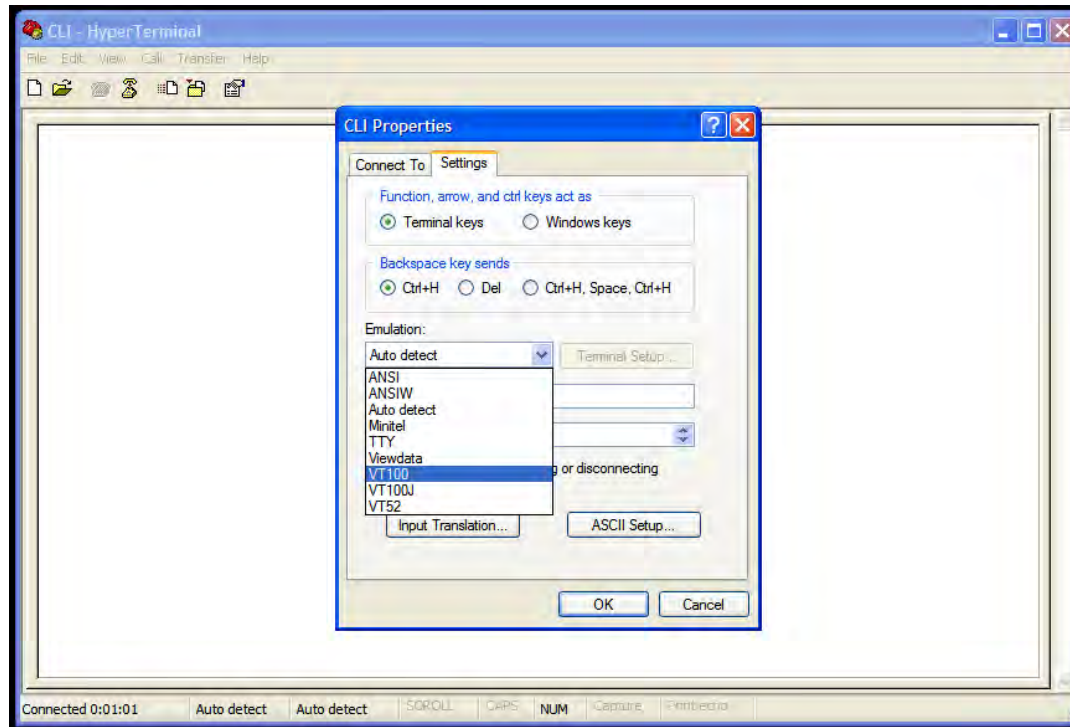

CLI

- In case that you cannot see login prompt, just press enter key several times.
Login is ‚admin‘ and Password is ‚admin‘.

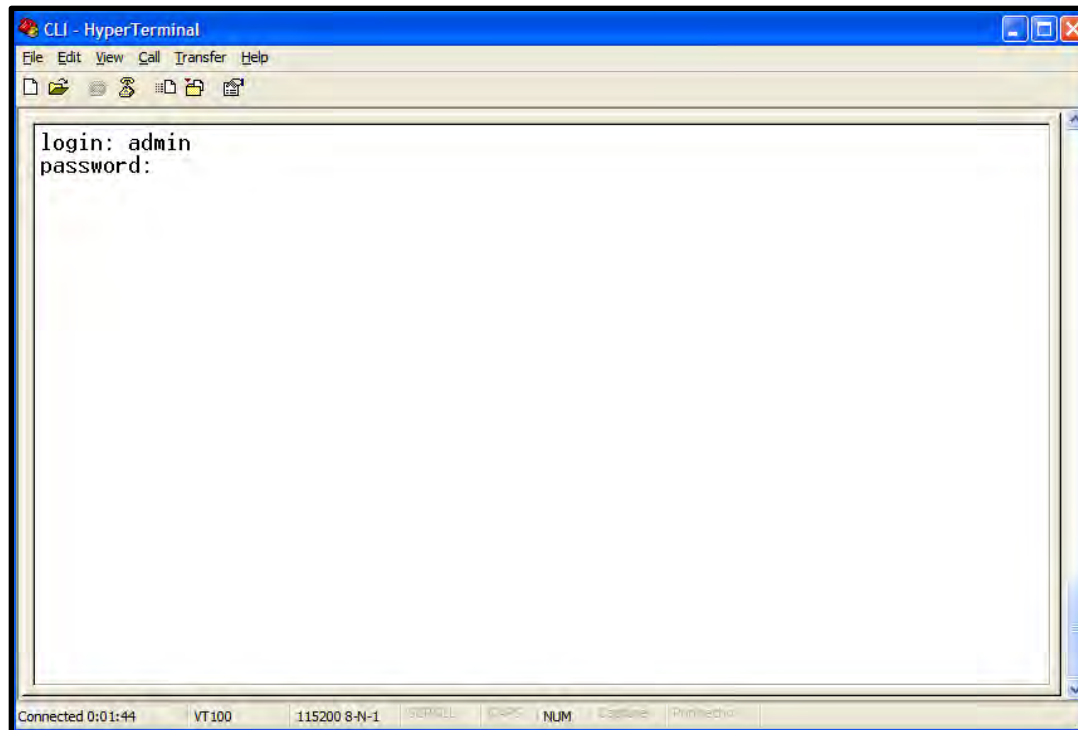

CLI

- In order to verify IP network configuration, you should type „communication’.
- Press enter-key.

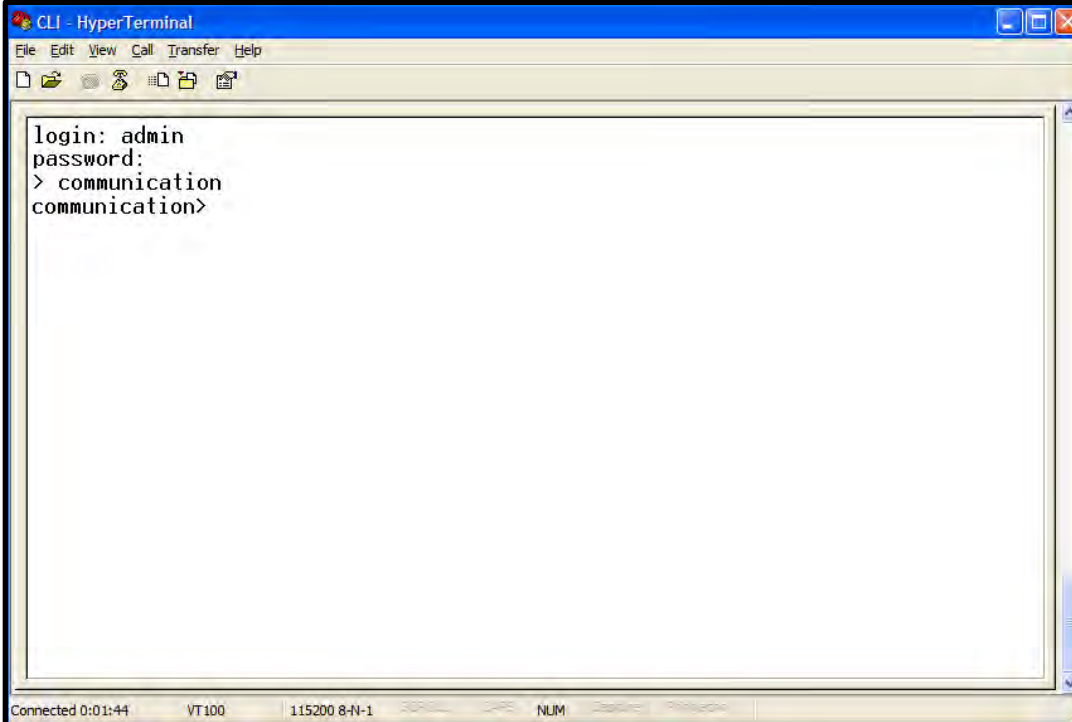

The image shows a HyperTerminal window titled "CLI - HyperTerminal". The window has a menu bar with "File", "Edit", "View", "Call", "Transfer", and "Help". Below the menu bar is a toolbar with several icons. The main text area contains the following text:
login: admin
password:
> communication
communication>
At the bottom of the window, there is a status bar with the text: "Connected 0:01:44 VT100 115200 8-N-1 NUM".

CLI

- In order to see values, you should type “get all”, and then press the enter-key.
- Enter the following text:
 - “set LAN_port_IP_address 192.168.2.1”, then press the enter-key.
 - “set LAN_port_DHCP_Server ON”, then press the enter-key.
 - “set WAN_port_IP_address 192.168.1.1”, then press the enter-key.
 - “set WAN_port_DHCP_Client OFF”, then press the enter-key.
 - “commit”, then press the enter-key.

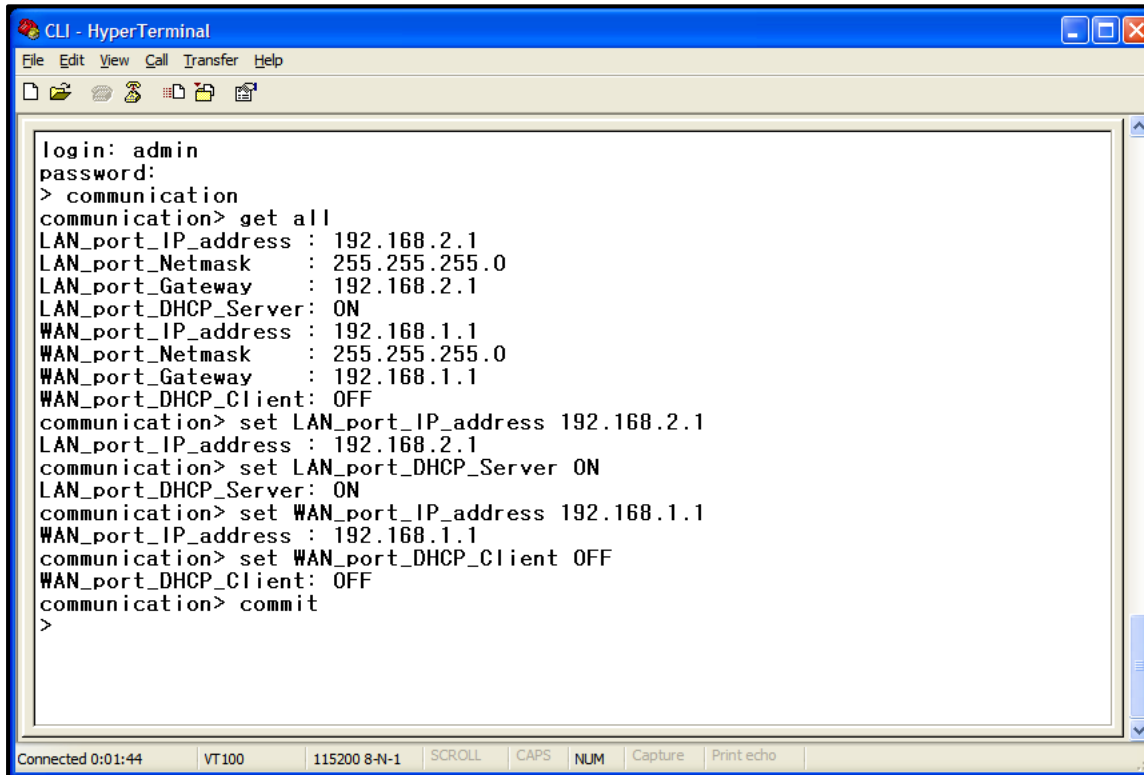

```
CLI - HyperTerminal
File Edit View Call Transfer Help
login: admin
password:
> communication
communication> get all
LAN_port_IP_address : 192.168.2.1
LAN_port_Netmask    : 255.255.255.0
LAN_port_Gateway    : 192.168.2.1
LAN_port_DHCP_Server: ON
WAN_port_IP_address : 192.168.1.1
WAN_port_Netmask    : 255.255.255.0
WAN_port_Gateway    : 192.168.1.1
WAN_port_DHCP_Client: OFF
communication> set LAN_port_IP_address 192.168.2.1
LAN_port_IP_address : 192.168.2.1
communication> set LAN_port_DHCP_Server ON
LAN_port_DHCP_Server: ON
communication> set WAN_port_IP_address 192.168.1.1
WAN_port_IP_address : 192.168.1.1
communication> set WAN_port_DHCP_Client OFF
WAN_port_DHCP_Client: OFF
communication> commit
>
```

Connected 0:01:44 VT100 115200 8-N-1 SCROLL CAPS NUM Capture Print echo

GST Technical Support

Phone:

Toll Free: 1-866-9 GST USA
Phone: 913-469-6699



Write:

GS Teletech Inc.
6900 College Boulevard, Suite 850,
Overland Park, KS 66211, USA



Product Information and Technical Assistance:

www.gsteletechinc.com
support@gsteletechinc.com



Specifications and features of this installation guide are subject to change without notice or obligation.



Warning: Exposure to Radio Frequency Radiation The radiated output power of this device is far below the FCC radio frequency exposure limits. Nevertheless, the device should be used in such a manner that the potential for human contact during normal operation is minimized. In order to avoid the possibility of exceeding the FCC radio frequency exposure limits, human proximity to the antenna should not be less than 20cm during normal operation. The gain of the antenna is 12 dBi. The antenna(s) used for this transmitter must not be co-located or operating in conjunction with any other antenna or transmitter.