

SmartCell Repeater User Manual

33 dBm

July, 2012

Version 1.0

- INDEX -

1. INTRODUCTION	3
1.1 GST SmartCell Repeater Advantages	5
1.2 Abbreviation.....	5
2. SYSTEM CONFIGURATION	7
2.1 SmartCell Repeater Service Network Configuration.....	7
2.2 System Design and Operation.....	8
2.2.1 System Design	8
2.2.2 Downlink/ Uplink Path	10
2.2.3 700MHz Frequency Selection	11
2.2.4 850MHz Frequency Selection	11
2.2.5 1900MHz Frequency Selection	12
2.2.6 2100MHz Frequency Selection	13
3. SETUP.....	14
3.1 Equipment Needed for Repeater Setup.....	14
3.1.1 Check points before turning on the Repeater.....	14
3.1.2 Ready for Service.....	15
3.1.3 Signal Strength LED Check	15
3.2 Setting up the Repeater	15
3.2.1 Quick GUI/Configuration.....	16
3.2.2 Quick Setup	16
3.3 WebUI Ranges Table.....	16
3.4 Troubleshooting	17
3.4.1 Simple Troubleshooting Method.....	17
3.4.2 Alarm Information	17
3.4.3 Troubleshooting Guide Related to RF	20
3.4.4 Troubleshooting Guide Related to NMS.....	22

U.S.A.

**U.S.FEDERAL COMMUNICATIONS COMMISSION RADIO FREQUENCY INTERFERENCE
STATEMENT INFORMATION TO THE USER**

NOTE: This equipment has been tested and found to comply with the limits for a **Class A** digital device, pursuant to Part 15 of the FCC Rules. These limits are designed to provide reasonable protection against harmful interference when the equipment is operated in a commercial environment. This equipment generates, uses, and can radiate radio frequency energy and, if not installed and used in accordance with the instruction manual, may cause harmful interference to radio communications. Operation of this equipment in a residential area is likely to cause harmful interference in which case the user will be required to correct the interference at his own expense.

These limits are designed to provide reasonable protection against harmful interference in a residential installation.

This equipment generates, uses, and can radiate radio frequency energy and, if not installed and used in accordance with the instructions, may cause harmful interference to radio communications.

However, there is no guarantee that interference will not occur in a particular Installation.

If this equipment does cause harmful interference to radio or television reception, which can be determined by turning the equipment off and on, the user is encourage to try to correct the interference by one or more of the following measures:

- Reorient or relocate the receiving antenna.
- Increase the separation between the equipment and receiver.
- Connect the equipment into an outlet of a circuit different from that to which the receiver is connected.
- Consult the dealer or an experienced radio/TV technician for assistance.

Changes or modification not expressly approved by the party responsible for compliance could void the user's authority to operate the equipment.

Connecting of peripherals requires the use of grounded shielded signal cables.

IC Warning

This device complies with Industry Canada licence-exempt RSS standard(s).

Operation is subject to the following two conditions:

- (1) this device may not cause interference, and
- (2) this device must accept any interference, including interference that may cause undesired operation of the device.

Le présent appareil est conforme aux CNR d'Industrie Canada applicables aux appareils radio exempts de licence.

L'exploitation est autorisée aux deux conditions suivantes : (1) l'appareil ne doit pas produire de brouillage, et

- (2) l'utilisateur de l'appareil doit accepter tout brouillage radioélectrique subi, même si le brouillage est susceptible d'en compromettre le fonctionnement.

1. INTRODUCTION

SmartCell is a modular repeater designed to improve signals in blanket/shadow areas inside buildings. It can transmit signals at 700MHz, 850MHz, 1900MHz, and 2100MHz frequencies. User may choose filtering configurations according to the specific site's requirements.

1.1 GST SmartCell Repeater Advantages

- It provides selectable RF power levels for any wireless technology / band.
- It provides monitoring for multiple technologies.
- Its digital filter provides optimized RF performance.
- It allows the users to modify the technologies via a web user interface.
- It is easy to add or change frequencies.
- It has scalable modular design.
- Data service is improved by the addition of 4G (LTE).
- Wall mount or rack mountable single chassis design.
- AMP modules are interchangeable and hot swappable.
- Optional low loss multiplexor allows user a centralized cable connection point for donor and service antennas.
- Multiples of same technology amplifiers can be used simultaneously.
- A single PSU provides power to the entire system up to 4 amplifier modules.

1.2 Abbreviation

DFM	Digital Filter Module
PSU	Power Supply Unit
ALC	Auto Level Control
SNMP	Simple Network Management Protocol
AOC	Auto Oscillation Control



CAUTION

- THIS EQUIPMENT IS INDOOR USE ALL THE COMMUNICATION WIRINGS ARE LIMITED TO INSIDE OF THE BUILDING
- RISK OF EXPLOSION IF BATTERY ON CONTROLLER BOARD IS REPLACED WITH AN INCORRECT TYPE.
- DISPOSES OF USED BATTERIES ACCORDING TO THE INSTRUCTIONS.
- THE SOCKET-OUTLET SHALL BE INSTALLED NEAR THE EQUIPMENT SHALL BE EASILY ACCESIBLE.
- THIS POWER OF THIS SYSTEM SHALL BE SUPPLIED THROUGH WIRING INSTALLED IN A NORMAL BUILDING.

IF POWERED DIRECTLY FROM THE MAINS DISTRIBUTION SYSTEM, IT SHALL BE USED ADDITIONAL PROTECTION, SUCH AS OVER VOLTAGE PROTECTION DEVICE.

2. SYSTEM CONFIGURATION

2.1 SmartCell Repeater Service Network Configuration

The SmartCell Modular Repeater is designed to improve coverage and capacity of LTE, PCS, Cellular, and AWS services. The repeater can provide in building coverage for all trouble areas. SmartCell is easy to install, has remote status monitoring and control functions (NMS System) via a wired line and wireless modem.

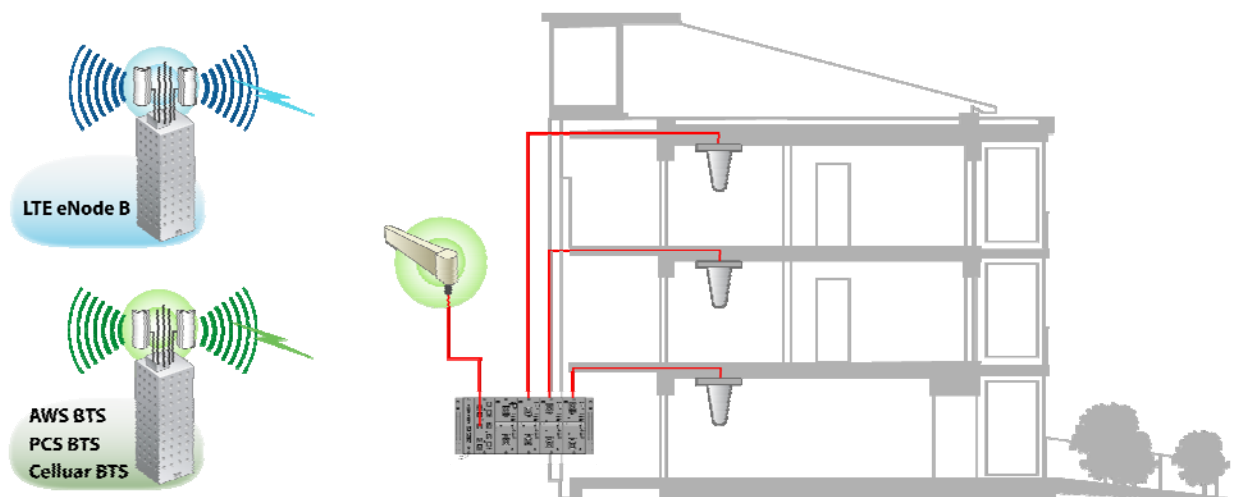

<Figure 1> In-building Repeater Service Organization

2.2 System Design and Operation

2.2.1 System Design

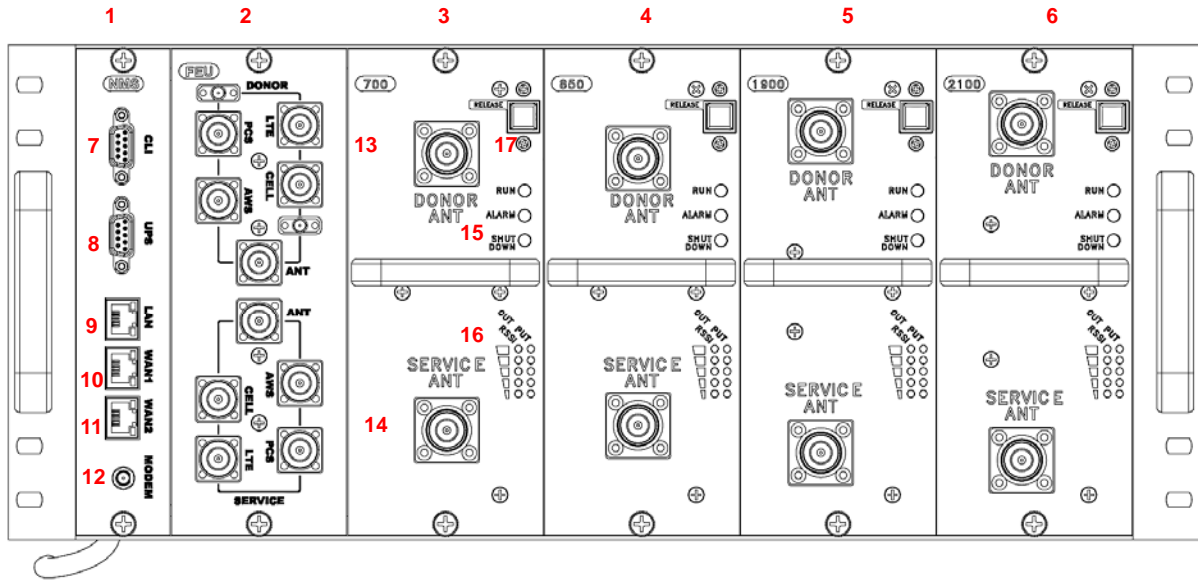

<Figure 2> SmartCell Repeater Front Design

NO.	PART	NO.	PART
1	SNMP	10	WAN 1 Port
2	FEU (Cavity Filter), optional	11	WAN 2 Port
3	Service Unit #1	12	Modem Antenna Connection Port
4	Service Unit #2	13	Donor Port(s)
5	Service Unit #3	14	Service Port(s)
6	Service Unit #4	15	Status LED (RUN/Alarm/Shutdown)
7	CLI	16	Input / Output LED
8	UPS	17	Release Button
9	LAN Port		

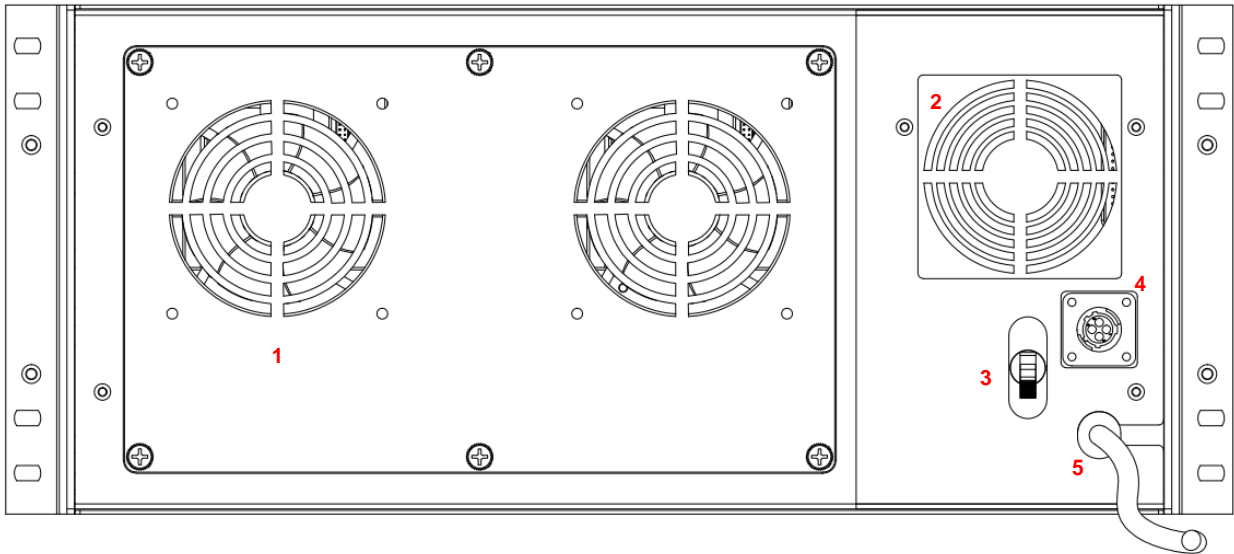

<Figure 3> SmartCell Repeater Back Design

NO.	PORT	NO.	PORT
1	Main FAN Assembly	4	DC 12V Output Connection
2	PSU FAN	5	Power Cable
3	Main Power Switch		

2.2.2 Downlink/ Uplink Path

The user may select frequency bands according to the site conditions. After receiving a signal from the donor antenna(s), the repeater improves it and sends a securely isolated signal out to the service antenna(s). Each amplifier module has its own separate digital filter module (DFM). The amplifier module consists of a down converter, up converters, cavity filter, and power amplifier (PAU).

In the Downlink Path:

1. RF Signal is received from the donor antenna through the input port.
2. The signal is then converted from RF to IF,
3. The IF signal is digitized by the DA converter,
4. The digital signal is filtered by the DFM (FPGA),
5. The modulator converts the digital signal to an analog RF signal and transmits to the amplifier.
6. Amplifier outputs final signal to service antennas at desired output power.

Uplink path works in reverse order.

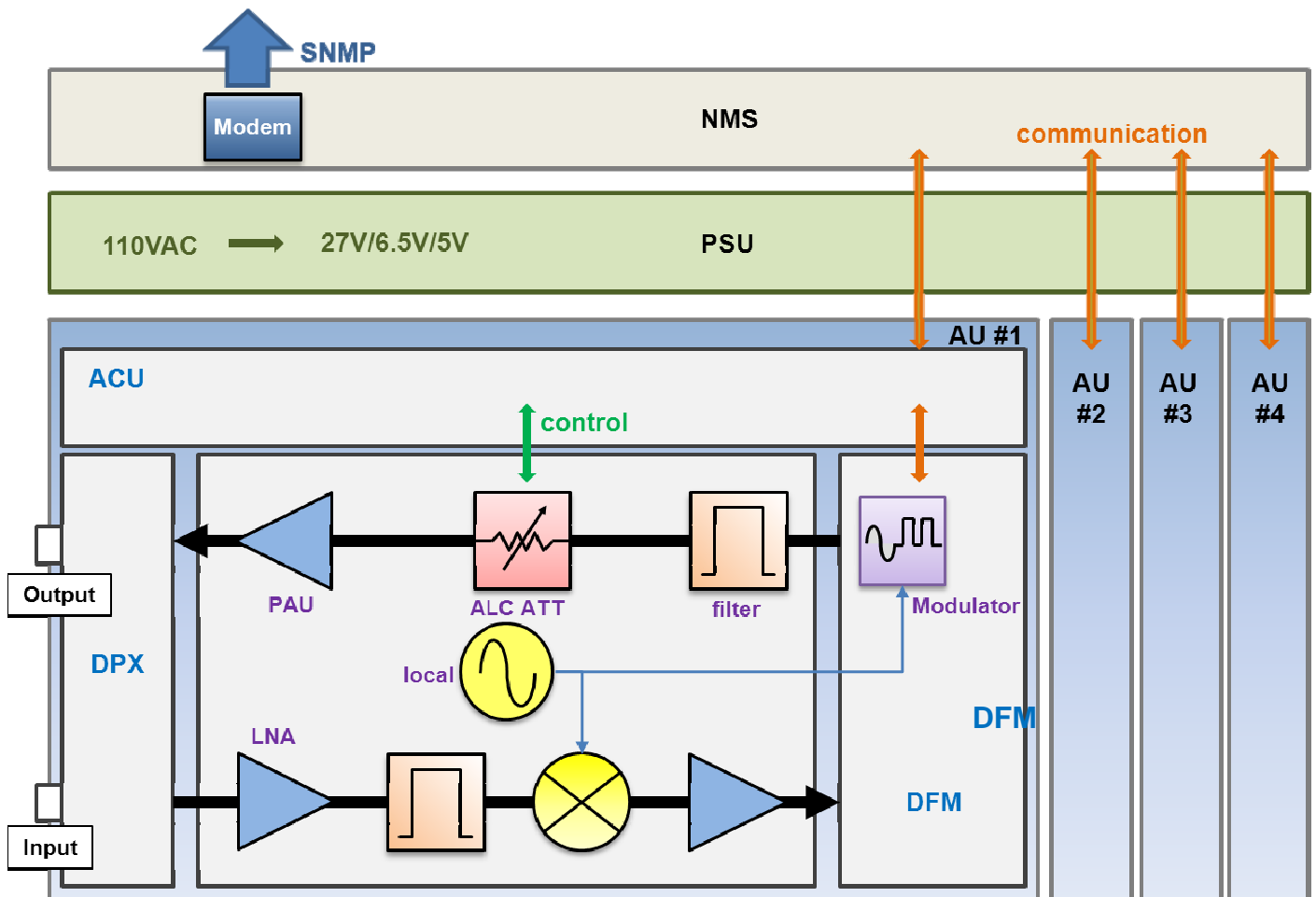

<Figure 5> SmartCell Repeater Block Diagram

2.2.3 700MHz Frequency Selection

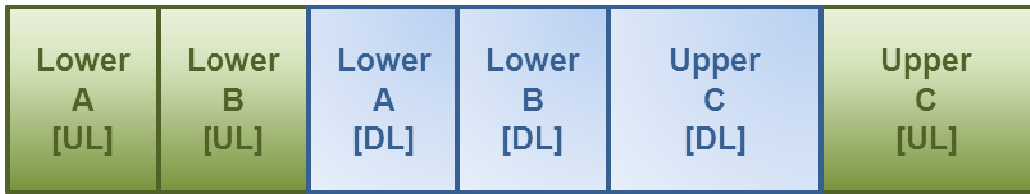

<Figure 6> 700MHz Band Frequency

The 700MHz AMP module complies with LTE 3GPP requirements, where a maximum of two non-contiguous block configurations are available. Each block is adjustable per 5 MHz.

2.2.4 850MHz Frequency Selection

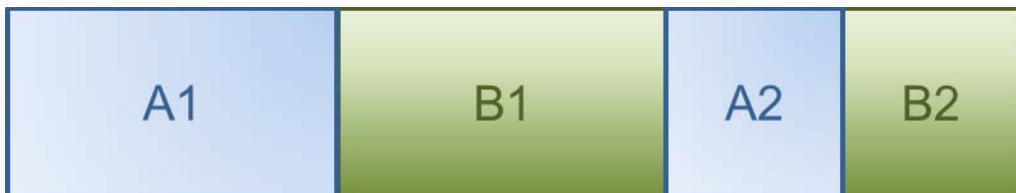

<Figure 7> 850MHz Band Frequency

The 850MHz AMP module provides Cellular service, where a maximum of two non-contiguous block configurations are available. Each block is adjustable to the following bandwidth configurations:

- A1: 11MHz
- B1: 10MHz
- A2: 1.5MHz
- B2: 2.5MHz

2.2.5 1900MHz Frequency Selection

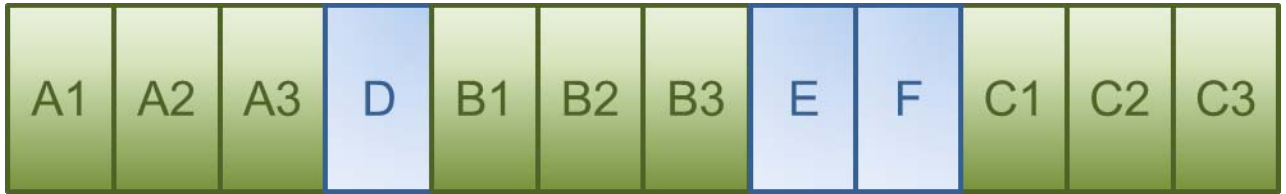

<Figure 8> 1900MHz Band Frequency

The 1900MHz AMP module complies with PCS Band blocks, where a maximum of three non-contiguous filtering configurations are available. Each sub block is adjustable per 1.25MHz bandwidth steps up to 20MHz. The Following table shows user selectable channel numbers.

BAND		DL CENTER [MHz]	CHANNEL	BAND		DL CENTER [MHz]	CHANNEL			
A	A1	1931.25	25	E	guard	1965	700			
		1932.5	50			1966.25	725			
		1933.75	75			1967.5	750			
	1935	100	1968.75			775				
	guard	1936.25	125	F	guard	1970	800			
	A2	1937.5	150			1971.25	825			
		1938.75	175			1972.5	850			
	guard	1940	200			1973.75	875			
	A3	1941.25	225	guard	1975	900				
		1942.5	250							
		1943.75	275							
	guard	1945	300	C	C1	1976.25	925			
D	1946.25	325	guard			1980	1000			
	1947.5	350								
	1948.75	375								
guard	1950	400	C2		1981.25	1025				
B1	1951.25	425			1982.5	1050				
	1952.5	450								
	1953.75	475								
guard	1955	500	C3		1983.75	1075				
B2	1956.25	525			guard	1985	1100			
	1957.5	550								
	1958.75	575								
guard	1960	600	G	1992.5	1225					
B3	1961.25	625								
	1962.5	650								
	1963.75	675								
							1250			
							1275			

2.2.6 2100MHz Frequency Selection



<Figure 9> 2100MHz Band Frequency

The 2100MHz AMP module complies with CDMA band requirements, where two block configurations are available. In order to set contiguous band F, check 'Band F1', 'Band F2' and 'contiguous' button in the WEB UI. In order to set Band F1 or Band 2 do not check 'contiguous' button in WEB UI. Band F configuration is as follows:

BAND		Downlink		Uplink	
		Start	Stop	Start	Stop
F	F1	2145.15	2149.85	1745.15	1749.85
	guard	-	-	-	-
	F2	2150.15	2154.85	1750.15	1754.85

3. SETUP

3.1 Equipment Needed for Repeater Setup

Parameter	Item	Quantity	Remark
Major Component	SmartCell Repeater	1 EA	Provided by GST
Additional Components	Wall Mounting Bracket	1 EA	Provided by GST
	CD which contains User Manual and Installation Guide	1 EA	
	Ethernet Cable 6.6ft (2m)	1 EA	
	Ground Cable 6.6ft (2m)	1 EA	
	Ground Sems Screw M4 x 8mm	4 EA	
	Bracket Sems Screw M5 x 10mm	20 EA	
	Lag Screw 12.7mm x 50.8mm	4 EA	
	FEU-AMP RF cable	8 EA	
	FEU-Wall Bracket RF cable	2 EA	
	Modem-FEU RF Cable	1EA	
Antenna	Donor ANT	1 EA	Not Included
	Server ANT	1 EA	
RF Cable	Antenna connection Cable	TBD	Not Included
Testing and Measuring Equipment	Spectrum Analyzer	1 EA	Not Included

3.1.1 Check points before turning on the Repeater

- 1) **System Power Check:** AC electrical power to the repeater should be 110V. Input electricity only after power verification.
- 2) **Input RF Signal Range:** Optimal input RSSI into the repeater is -57dBm ~ -27dBm for 700MHz/850MHz/1900MHz/2100MHz. User should verify input condition of Donor ANT. If the input RSSI exceeds -27dBm, then external attenuators should be added.
- 3) **Isolation check between DONOR/SERVER ANT:** Isolation condition of this equipment is 105dBc (Gain+15dB). The User should check this condition before installation.

3.1.2 Ready for Service

1. Check points before Service:

a. Verification of system installation:

- Electricity, In/Out antennas, cable connections, and equipment mounting.

b. Verification of system accessories:

- User should check all necessary accessories.

c. Check received signal level:

- User should check whether environmental conditions are in accordance with system specifications to ensure the system operation will be optimized.

2. Check points after Service:

a. Check external LEDs

1) RUN: Green light ON (Off: all lights off).

2) ALARM: Green light in normal status, Red light in alarm.

3) SHUT DOWN: Green light in normal status, Red light in Shutdown.

3.1.3 Signal Strength LED Check

Number of LED bars	Input Signal Level	Output Power Signal Level
LED 1 bar	Less than -86dBm	Less than +5dBm
LED 2 bars	-85dBm ~ -79dBm	+6dBm ~ +10dBm
LED 3 bars	-78dBm ~ -72dBm	+11dBm ~ +15dBm
LED 4 bars	-71dBm ~ -65dBm	+16dBm ~ +20dBm
LED 5 bars	More than -64dBm	More than +21dBm



Figure 9> Modular Repeater Front LED

4.2 Setting up the Repeater

3.2.1 Quick GUI/Configuration

Use the following steps to commission the Repeater after all the cabling and antennas are fixed in place and the Repeater is supplied with proper electrical power. The repeater will need a stable Downlink RSSI input level in the range of -85dBm to -60dBm.

1. Connect your laptop to the LAN port on the repeater with a Crossover Ethernet cable.
2. Verify your laptop has all wireless connections turned off and is set to obtain an IP address automatically, or you may use a fixed IP address: 172.16.6.82, with a Subnet Mask of 255.255.255.252, no default Gateway.
3. Open web browser and enter: 172.16.6.81.
4. User name: admin.
5. Password: admin.

3.2.2 Quick Setup

1. Go to the RF Configuration page.
2. Before the Amplifier (HPA) can be turned on, set the Uplink and Downlink attenuation (ATT) to the maximum value and click Apply.
3. Select the correct Band Block and set the ALC Downlink and Uplink Limits to the desired level and click Apply. (To adjust the Output Power, change the ALC Downlink and Uplink Limits to the desired levels).
4. To check the Repeater's status, click on the Status page.
5. To change the Repeater's gain, adjust the Uplink and Downlink attenuation in equal amounts not more than 5dB at a time and click Apply.

3.3 WebUI Ranges Table

GUI Feature	Range	Description
Downlink and Uplink Output Power Display	Below 0dBm to 35dBm	The output Power of the Repeater
Downlink Low RF Power	2dB to 10dB	Threshold for Low RF Power
Downlink and Uplink Attenuation Control	0dB to 30dB	Reduces Gain Internally
Downlink and Uplink ALC Limit	0dBm to 33dBm	Limits Output Power
Downlink RSSI Display	-100dBm to -27dBm	Downlink Receive Level at Donor Antenna Port
Downlink Low RSSI	-93dBm to -57dBm	Threshold for Low RSSI
Downlink and Uplink AMP	On/Off	High Powered Amplifier

Control		
Gain Balance Control	On/Off	Equalizes Uplink and Downlink Gain
Gain Balance Value	0dB to 15dB	Subtract Uplink Gain by G/B Value
Shutdown Control	On/Off	Shutdown if Major Alarm is Reported
Auto Gain Setting	On/Off	Automatic Gain Setting for the Repeater
Auto Oscillation Control	On/Off	Prevents Oscillation
Temperature Display	32 to 260.6 Degrees	Internal Repeater Temperature
AMP Temperature Upper Limit	0 to 299 Degrees	Threshold for Temperature Alarm
Band Blocks Used/Bandwidth	Each AMP	The Channel the Repeater will be using
Delay Alarm Report	0 or 5 Minutes	Time Delay of Reporting after Alarm is Detected

3.4 Troubleshooting

In case of abnormal operation, technician should diagnose abnormality via remote access or directly connecting to repeater using Ethernet cable. If technician is required to conduct repairs due to major alarm, repeater should first be powered off, and then technician should prepare the proper measurement equipment before trying to fix the problem.

3.4.1 Simple Troubleshooting Method

- 1) Verify LED Status, both on external LED's as well as internal module LED's
 - Normal operation: Green light on. Alarming: Red LED on.
- 2) Technician should check external and internal connectors to ensure all connections are tightly secure. These connectors should be cleaned regularly.
- 3) If technician thinks there is a serious problem, call technical support.
1-866-9-GST-USA (1-866-947-8872)

3.4.2 Alarm Information

Alarm Name	What causes this alarm	Troubleshooting Methods
Downlink Spurious emissions out of spec	Downlink Output Power exceeds Downlink Upper Limit	<ul style="list-style-type: none"> * The Downlink Output Power should not exceed the maximum composite power spec for this unit. * If the Downlink Output Power is not exceeding the composite power spec for this unit, try to increase the Downlink Upper Limit on the RF Configuration Page. * Add equal amounts of Uplink and Downlink attenuation until the Downlink Output Power is less than the Downlink Upper Limit. * Set the ALC Downlink Limit on the RF Configuration Page to a value lower than the Downlink Upper Limit
Downlink Hardware failure	Downlink path gain is 6dB less than RSSI pl	<ul style="list-style-type: none"> * By default, if the Downlink Low Output Variance is set to 10dB, the Repeater will not report this alarm.

	Downlink Output Power	<ul style="list-style-type: none"> * Increase the Downlink Low Output Variance on the RF Configuration Page.
Downlink Donor power too low	Input RSSI from Donor site is 8dB less than Downlink Low Input Limit	<ul style="list-style-type: none"> * By default, if the RSSI Lower Limit is set to -93dBm, the Repeater will not report this alarm. * Decrease the Downlink Low RSSI Limit level on the RF Configuration Page. * Increase the RSSI level into the Repeater.
Downlink VSWR	When the VSWR Ratio on the Server Port is greater than 3 : 1	<ul style="list-style-type: none"> * "Sweep the line" to check for loose or damaged connectors and/or cabling. * If after checking the entire Server side, the VSWR alarm still exists and the system is working fine, Disable the alarm on the Alarm Configuration page.
Downlink Donor power too high	Downlink Input Power is greater than -25dBm	<ul style="list-style-type: none"> * Check position of the Donor antenna. * Add attenuator to the Donor port at the highest input power level.
Downlink Synthesizer failure	Failure of the synthesizer Downlink path	<ul style="list-style-type: none"> * Turn OFF/ON the System by pressing ON/OFF button on the back side panel. * Call GST's Tech Support Team and exchange the AMP unit.
Downlink Interference power exceeded	Out-band signal is about 15dB greater than in-band signal	<ul style="list-style-type: none"> * Call GST's Tech Support Team for further instructions.
Uplink Out of band emissions out of spec	Uplink Output Power exceeds Uplink Upper Limit	<ul style="list-style-type: none"> * The Uplink Output Power should not exceed the maximum composite power spec for this unit. * If the Uplink Output Power is not exceeding the composite power spec for this unit, try to increase the Uplink Upper Limit on the RF Configuration Page. * Add equal amounts of Uplink and Downlink attenuation until the Uplink Output Power is less than the Uplink Upper Limit. * Set the ALC Uplink Limit on the RF Configuration Page to a value lower than the Uplink Upper Limit
Uplink Power at coverage port too high	Uplink Input Power is greater than -25dBm	<ul style="list-style-type: none"> * Check position of the Coverage antenna. * Add attenuator to the coverage port or use another device to regulate Uplink output power.
Uplink Synthesizer failure (Uplink Hardware failure)	Failure of the synthesizer Uplink path	<ul style="list-style-type: none"> * Turn OFF/ON the System by pressing ON/OFF button on the back side panel. * Call to GST's Tech Support Team and exchange the AMP unit.
Uplink (Downlink) Software failure	Alarming in DFM of the amplifier unit	<ul style="list-style-type: none"> * Turn OFF/ON the System by pressing ON/OFF button on the back side panel. * Call to GST's Tech Support Team and exchange the AMP unit.
Oscillation detected/Low isolation	Insufficient isolation is detected when the Repeater is at minimum gain	<ul style="list-style-type: none"> * Verify that the Donor antenna is on the same side of the building as the Donor site, and if needed, raise the Donor antenna up on a pole. * Change the types of antennas used, such as Yagi to Corner-Reflector for outdoors, and Omni to a Panel for indoor

		<p>use.</p> <ul style="list-style-type: none"> * Move the closest indoor service antenna farther away from the outside Donor antenna. * Close the repeater door if opened and verify that the closest indoor coverage antenna is not in the same room as the repeater.
Field Replaceable module failure	Mismatch of AMP unit and filter service in DF M	<ul style="list-style-type: none"> * Call GST's Tech Support Team to verify all the settings are correct.
Tamper Detected	Change of mounting information in the System	<ul style="list-style-type: none"> * Wait 5 minutes to clear alarm automatically. * If you want to disable, you can on the Alarm Configuration page.
Communication Failure	Bad connection of NMS board and AMP unit	<ul style="list-style-type: none"> * SNMP board or AMP unit need to reset. * Open the rear cover and check the each cable.
Power Supply out of range	The internal Power Supply detects improper Voltage	<ul style="list-style-type: none"> * If the system is working fine, disable the alarm on the Alarm Configuration page. * Call to GST's Tech Support Team to verify that all the settings are correct.
Over Temperature	Internal AMP temperature exceeds the Temperature Limit	<ul style="list-style-type: none"> * Verify the Temperature Limit is set between 176 °F ~ 201 °F on the RF Configuration page. (Default Value is 163°F)
Reset alarm	During reset of the unit,	<ul style="list-style-type: none"> * Wait 30 seconds to clear alarm automatically.
Manual Shutdown	During the shutdown algorithm after re-check the system is completely shut downed.	<ul style="list-style-type: none"> * Turn OFF/ON the System by pressing ON/OFF button on the back side panel. * Reset AMP unit in WebUI.
FAN	FAN Failure	<ul style="list-style-type: none"> * Replace FAN.

3.4.3 Troubleshooting Guide Related to RF

Item	Check Point	Troubleshooting
Check before system operation	System input power range	-Downlink: -100dBm ~ -27dBm -Uplink: -100dBm ~ -27dBm
	System gain (DL/UL)	- 60dB ~ 90dB
	Output power at server port	- Downlink: 33dBm ± 2dB - Uplink: 33dBm ± 2dB
	Check points before open for service	-Please check quantity of all accessories with specification before you set up -Fit cable length in accordance with field condition
Check after system operation	Check points after open for service	Check following status; -Verify the antennas are securely mounted and pointed in the correct directions -Connection status between antennas and RF cable -Verify the Repeater is securely mounted -Proper AC power status -Grounding status of electrical circuit -Coaxial cable (RF) construction status -Connectors and combiners connection status -Cable connection status against leakage of water
When repeater does not work properly	Check electricity cord connection status	-Re-plug in Adapter cord
When in alarming	DL VSWR alarm	Check following status; -Make sure Server Antenna Port is disconnected. -Reset Adapter upon completing Alarm troubleshooting
	DL over-output alarm	-Make sure output power is operating normally -Reset Adapter upon completing Alarm troubleshooting
	UL over-output alarm	-Make sure output level is operating normally -Reset Adapter upon completing Alarm troubleshooting
	Temperature alarm	Check following status; -Setting level of maximum temperature limit -Temperature offset is normal or not -Circumstances of temperature -Reset Adapter upon completing Alarm troubleshooting
	RF off	-Verify the HPA's are On -Reset Adapter upon completing Alarm troubleshooting
When output power is no longer	Technician should verify category of alarm at the front side of repeater	-Red light on the Shutdown LED, technician should troubleshoot the alarm via Notebook computer

problem	-Technician should connect antenna with output port of repeater -Make sure all connectors are fastened	-Reconnect the connector -Change it if the connector is defective
	Check the input level	-Increase output power or check input change of BTS side
	Check gain of the unit	-If the Gain is different from normal level, please contact GST's Technical Support
	Cable connector loose	-It is possible for connectors to get too tight and damage the equipment or throughput -Contact installer or service provider
In case of dropped call or bad signal after set up	Check input signal strength in the service area	-Increase output power level of repeater by adjusting attenuation level
	If input signal strength is not a problem, please check delay of calling time	-Increase output level of Uplink signal, then set to optimal level.
	Check RSSI signal strength	-Contact network management team or service provider
In case output Signal wavelength is not shown flat or looks like oscillation	Check connection fastened between antenna and cable (Signal wavelength should be flat and stable if technicians shake CABLE. If not, it is connection problem)	-If connection is not proper, reconnect cable and connector and then check the output power again
	Input level change or module overheating	-Check input level from BTS side. -Check performance of each module (Diagnosed by GST's Technical Supportm)
	Please check VSWR of the cable is normal	-Change to normal Cable

3.4.4 Troubleshooting Guide Related to NMS

Symptom	Check Points	Troubleshooting
Link Fail	Communication problem	-In case of Ethernet, verify IP addressing, DHCP function, and that cookies are deleted -Verify that a crossover Ethernet cable is being used
	CLI connection, cable status check	-Make sure 1:1 connection -Follow instructions in the installation guide for this connection procedure
	CLI connection Check by USB to serial cable	-Verify port number of PC communication -Check cable connection status

If technician thinks there is a serious problem, call GST's Technical support.

1-866-9-GST-USA (1-866-947-8872).

MPE Information

	<p>Warning: Exposure to Radio Frequency Radiation The radiated output power of this device is far below the FCC radio frequency exposure limits. Nevertheless, the device should be used in such a manner that the potential for human contact during normal operation is minimized. In order to avoid the possibility of exceeding the FCC radio frequency exposure limits, human proximity to the antenna should not be less than 50 cm during normal operation. The gain of the antenna is 9.0 dBi. The antenna(s) used for this transmitter must not be co-located or operating in conjunction with any other antenna or transmitter.</p>
---	---