

Exhibit E

User's Manual

GUARDIAN ACCESS CORPORATION

FCC ID.: N6U303STX

**Remote Control Garage Door Opener
(TRANSMITTER)**

GUARDIAN ACCESS CO

98TE61409

E189028

Residential Garage Door Opener

Model 2211-L

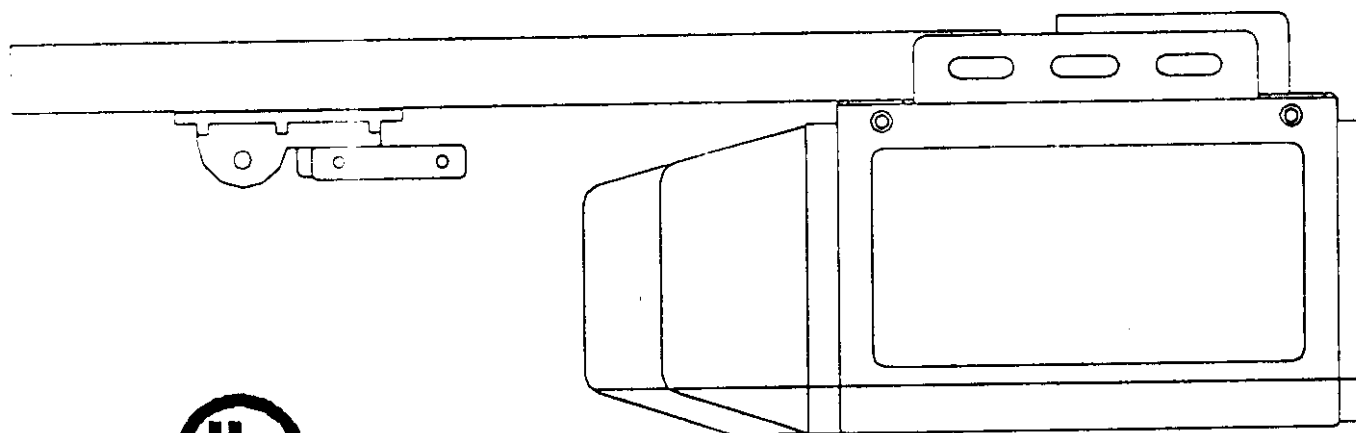

Read this manual
carefully before
beginning installation

Installer: Place this
manual in the plastic
envelope provided
and permanently
attach to the wall

Residential Garage Door Opener Installation Instructions and Owner's Manual

TABLE OF CONTENTS

SAFETY RULES.....	02
BEFORE STARTING.....	02
PRE-ASSEMBLY CHECK.....	02
Product Features/Specifications.....	03
Door Test	04
Component Identification, Inventory, Accessories.....	05
Tools Required	06
Assembly Instructions	07
Installation Notes & Instructions.....	08-13
Setting/Changing Transmitter Codes.....	14
Installation of PhotoEyeSystem	15-17
OPERATION AND ADJUSTMENT INSTRUCTIONS	
SETTING THE LIMITS	18
SETTING THE SENSITIVITY FORCE	19
TESTING THE OPENERS REVERSING SYSTEM...20	
TESTING THE PHOTOEYESYSTEM.....	21
FINAL INSTALLATION.....	22
TROUBLE SHOOTING.....	23
AFTER THE INSTALLATION.....	24
Opener Wiring Schematic.....	25
Parts Breakdown.....	26-27
Warranty	28

Notice

All Model 2211-L Garage Door Openers are Designed and Tested to Offer Safe Operation, Provided Installation and Use of this Product is Followed in Strict Accordance with these Instructions for Assembly and Installation. Failure to Comply with these Instructions Could Cause Property and/or Bodily Injury. The Opener is Intended Only for the Use Described in this Manual and Use Other than Intended will Void Any and All Warranties Herein Described.

Read and Follow These Important Safety Rules:



You will see Warning and Caution Statements on the following Pages. Read and Follow these Safety Instructions Carefully. Failure to do so could result in Serious Personal Injury or Death.

Warning means that severe injury or death may result from failure to follow instructions

Caution means that property damage or injury may result from failure to follow instructions

Be sure to read and follow all instruction carefully	Locate lighted push button within sight of garage door , away from all moving parts and out of reach of children (minimum 5' above floor).
Check to make sure the garage door is properly installed and balanced. Because of the extreme tension most garage door parts are under do not attempt to adjust on your own. Have a qualified garage door service person make repairs to cables, springs and other hardware before installing the opener.	Install Entrapment Warning Label next to control button. Read the Contol Adjustment Warning Label. Install Emergency Release Tag to the Emergency Release Cord. Mount the Emergency Release Knob 6 feet from the floor. Use the manual release <u>Only</u> to disengage the trolley. Do not use the Red Release Cord and Knob to pull door up or down.
Do not connect opener to power source until instructed . Install door opener 7 feet or more above floor.	After installing opener , the door must reverse when it comes in contact with a 1-1/2" high object. Check this safety feature often.
Remove all ropes connected to the garage door.	Never operate the opener if the system is not operating properly.
Disengage all existing garage door locks to avoid damage to the garage door	Always disconnect electric power before making repairs or removing cover.
Fiberglass, Aluminum and Steel Doors must be Reinforced to Prevent Damage. Consult with Manufacturer for Recommendations.	Activate opener only when the door is in full view and free from obstructions.
All installation and wiring must be done in strict compliance with local and state building and electrical codes. Connect the power cord to a properly grounded outlet only. Do not in any way alter or remove the grounding pin.	No one should enter or leave the garage while the door is in motion. Do not allow children to play near, or operate the door .
Photo Electric Eyes must be installed properly. Opening doors must not close and Closing doors must open. See test procedure	After Installation is complete fasten this manual near the garage door. Perform periodic safety checks and recommended

Product Features

page 3.

- 1. Motor:** Permanently lubricated, thermally protected, heavy duty motor with automatic reset.
- 2. Opener Lights:** Turn on and off automatically with 4-1/2 minute illumination for your safety and convenience.
- 3. Sensing System:** A built-in sensing system detects obstructions during door operation. If in the Downward (close) travel mode, the Opener will sense an obstruction and reverse to the full open position. In the Open mode, the Opener will stop. In both cases the light will start flashing and continue to flash for 4-1/2 minutes. Since all doors are different, the Sensing System has independent adjustments for customizing the level of force for the normal opening and closing of specific door.
- 4. Close Limit Switch:** In winter months it's common for small pieces of ice or packed snow to be trapped under the door. Ground swelling may also effect the close limit setting of the Opener. The Close Limit Switch overrides the Sensing System during the last one (1) inch of closing travel and prevents the door from reversing if it encounters an obstruction at this point.
- 5. Emergency Release:** A pull cord allows manual disconnect and operation of door during power failure. Unit will automatically reconnect when release is reset (the trolley release lever is snapped back to its original position), power is restored and Opener is activated.
- 6. Mechanical Door Lock:** When properly adjusted, opener locks door in closed position preventing unwanted entry.
- 7. Easy Connect Continuous Monitor Entrapment System:** System allows quick and easy installation of "Silent Guard" Photoeyesystem while Control circuitry monitors these devices continuously for proper operation.
- 8. Constant Contact to Close:** for utmost safety if "Silent Guard" Photoeyesystem fails constant contact of mechanical push button is necessary to close door. In this mode of operation, a radio transmitter cannot be used to close door.
- 9. Momentary Contact to Close:** Single touch to Radio Transmitter or Wall Button will allow door to close as long as "Silent Guard" Photoeyesystem is operational.
- 10. "Silent Guard" Photoeyesystem:** An invisible infra-red beam of light guards the door opening and reverses a downward moving door if the beam is broken by a stationary or moving object. If the beam is broken, the opener light will flash for 4-1/2 minutes. Motor control circuitry constantly monitors the "Silent Guard" Photoeyesystem for proper operation.
- 11. Digital Radio Controls:** Built in allowing over 1.6 million private codes, easily selected without use of tools. Bright transmitter LED indicates operation and monitors battery condition.

Door Test

page 4.

Before beginning installation of the operator please complete the following test to insure that your door is balanced and in good working condition. A poorly balanced door could cause severe personal injury and damage to the opener.

Always have a qualified garage door service person make any needed adjustments and/or repairs to your door before proceeding with installation.

1. Raise and lower the door and check closely for areas of sticking and binding. Check for loose hinges, wobbly rollers, frayed cables and damaged or broken springs. Contact a qualified garage door service person to make the necessary adjustments.

2. Lift the door approximately halfway. When released, the door should stay in that position. If door pulls open or moves downward, the spring mechanism is not adjusted properly. Contact a qualified garage door service person to make the necessary adjustments.

3. When properly installed and adjusted the door will remain clear of the opening, when allowed to rest at its natural full open position. If door drifts up or down the door is not adjusted properly. Contact a qualified garage door service person to make the necessary adjustments.

Do Not Install the Opener Until These Adjustments and Repairs Have Been Made.

Carefully follow the instructions for the assembly and installation of the garage door opener contained in this manual

Components Identification and Inventory

Package Contents

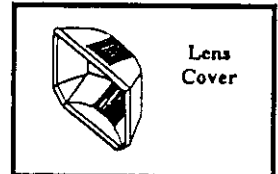
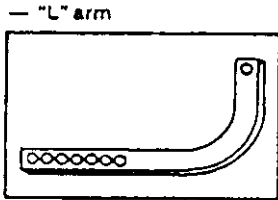
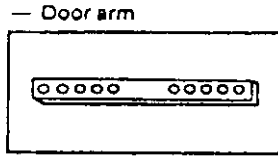
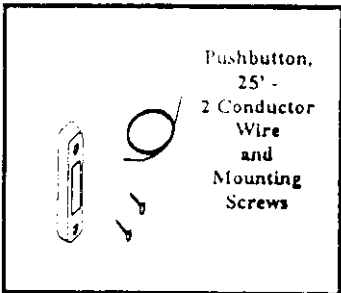
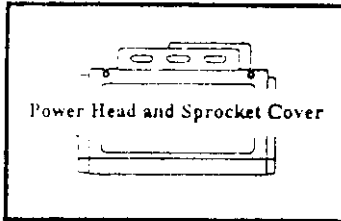

- Transmitter includes
 - transmitter
 - battery
 - visor clip

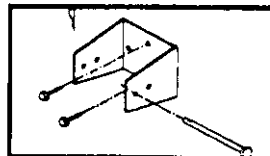
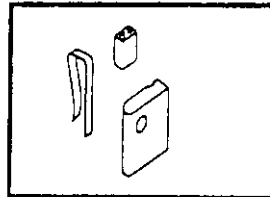

- Door bracket

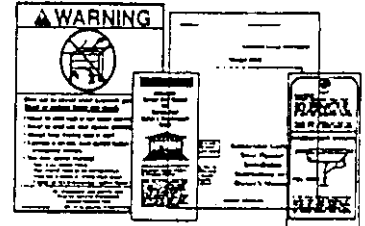

Owners Manual, Pushbutton Caution Label, Release Cord Label, Safety and Maintenance Guide

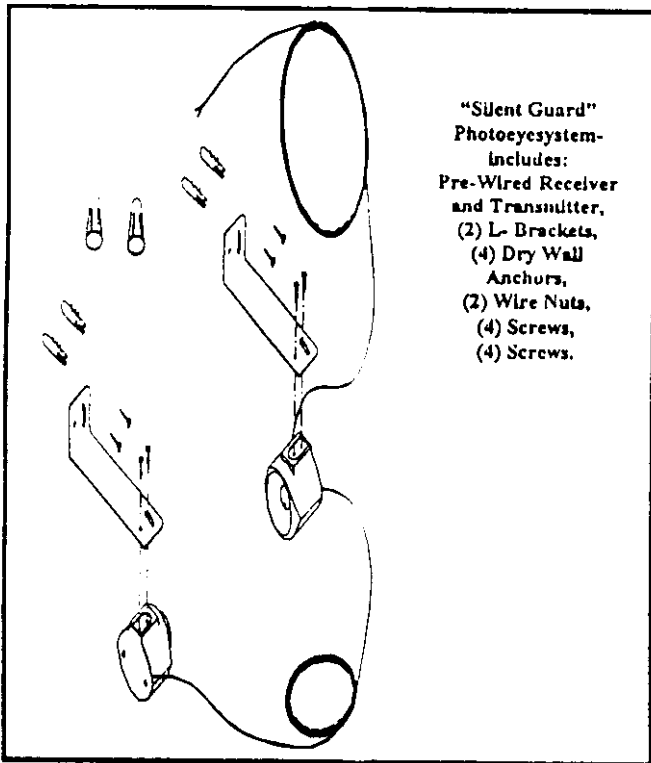

L-Rail/Chain Speed Unit Assembly Includes: L-Rail, Chain, Front Pulley Assembly, Inner and Outer Trolley System, Safety Stop Nut and Bolt.

Header Bracket Assembly

Hardware Bag Contains:

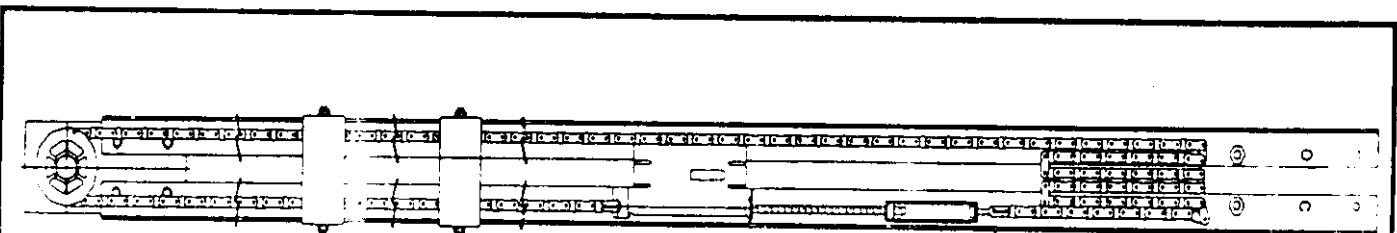
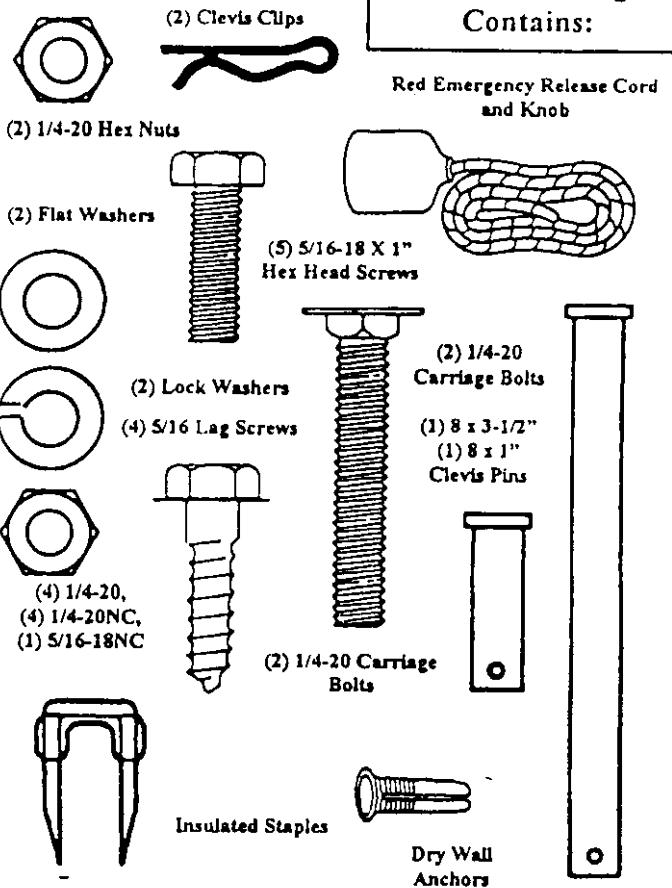

Tools Required for Assembly and Installation

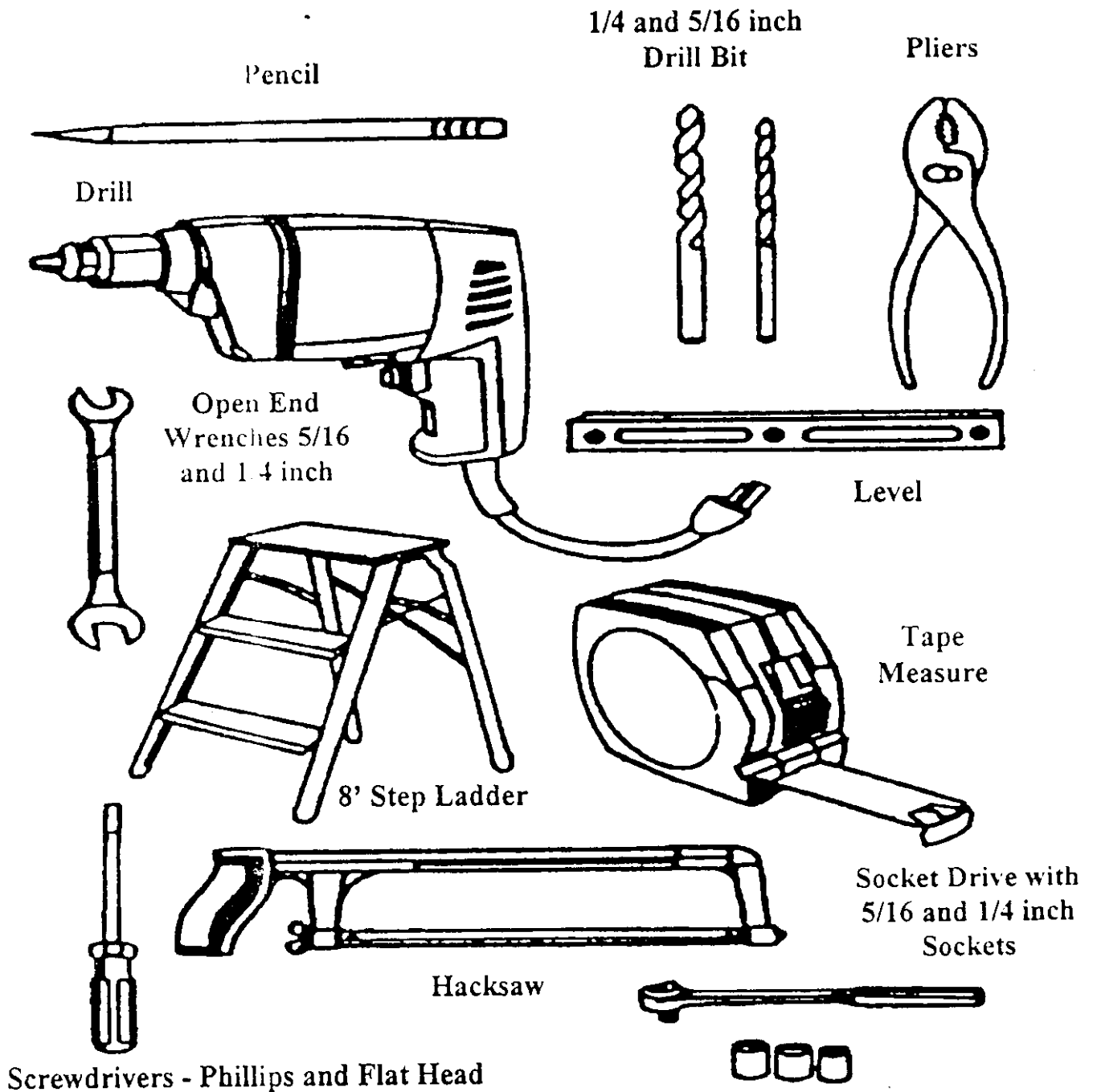

Supplies (Needed but not supplied) :

- One Rough Service light bulb 75 watts or less
- Hanging Stock - Perforated Steel Angle Mounting Material
- Wood Block

Assembly

page 7.

Note: The L-Rail Chain Speed Unit Assembly with Trolley and Front Idler Sprocket is packaged separately from the Power Head Unit. Refer to page 5. for package contents and identification.

Step 1. Place Power Head Unit on discarded packing material/cardboard. Remove the four (4) 5/16" hex nuts . See Figure 7B. Save for use later.

Step 2. Remove L-Rail/Chain Speed Unit from box . Locate Installation Hardware Package.

Step 3. Remove tape used to keep chain tight during shipping and discard

Step 4. Loop the chain around the drive sprocket on top of the Power Head Unit (fig 7B) . Carefully position L-Rails on the studs and secure with nuts and washers removed in Step 1. Slowly apply tension to the chain by tightening the outer nut on the Chain Tension Bracket (fig 7A). Remove remaining tape from the L-Rail/Chain Speed Unit Assembly. Re-check chain alignment at drive sprocket and front idler

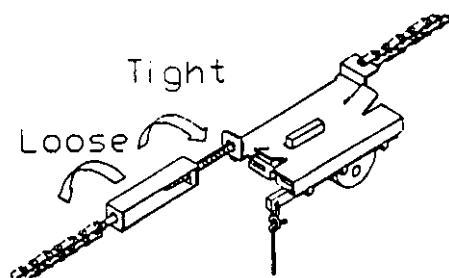

Figure 7A

Tighten the inner and outer nuts on the chain tension bracket until the chain is properly adjusted. Make sure the chain does not twist. When adjusted properly, the chain should show no droop and be approximately 1/2" above the base of the L-Rail. Note: Improper chain adjustment (too loose or too tight) can result in improper operation and/or excessive sprocket and chain noise.

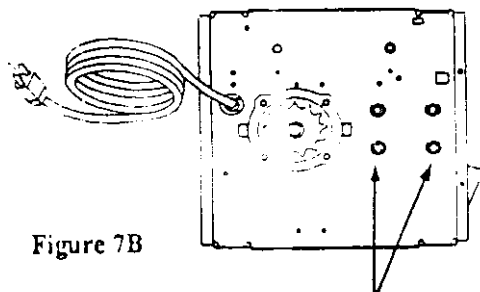
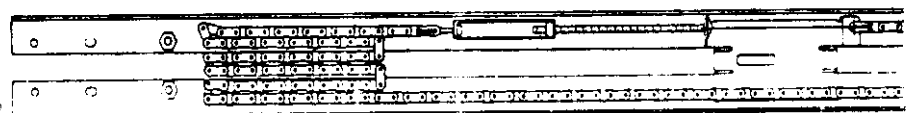

Figure 7B

5/16" hex nuts



Step 5. Re-check all nuts for tightness. Re-check chain tension

Assembly is now complete. You are ready to begin installation of the opener

Installation

Installation procedures will vary depending on type of garage door. Identify your garage door from those illustrated below and follow procedures outlined for your type of door. Figure 8A.

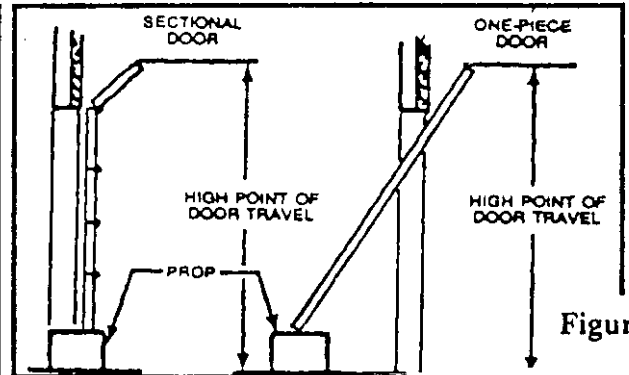
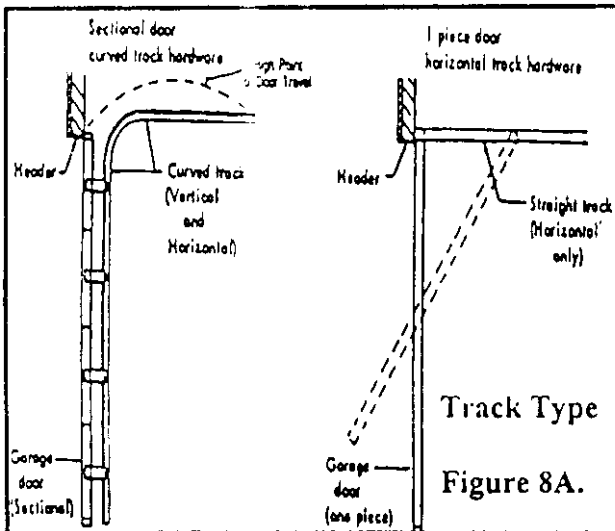

Figure 8B.

To determine high point of door, raise the door slowly, until it reaches its highest point of travel. Place support block under the door and measure the distance from the floor to the top edge of the door. Remove block and lower door.



Springs, Pulleys, Cables and Mounting Hardware That Balance Your Garage Door Are Under Tremendous Pressure At All Times And Can Cause Serious Injury Or Death if Distrubed . Do Not Attempt Adjustment !

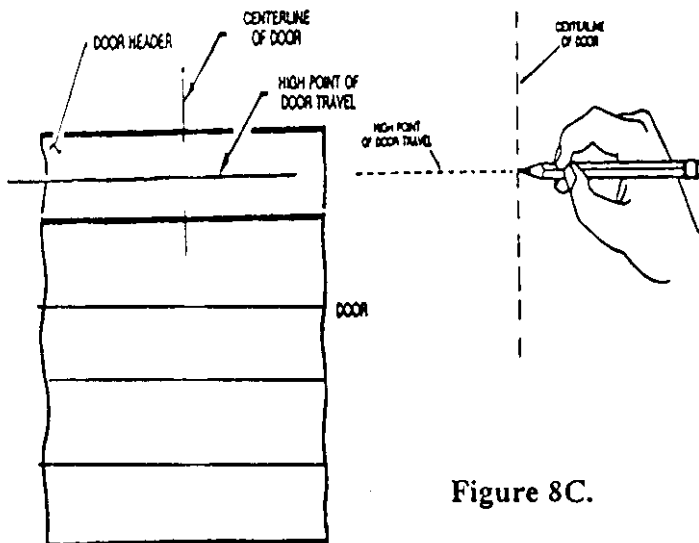

Figure 8C.

Step1. Mounting the Front Bracket (Sectional Doors and One-Piece with Track.) Mark a vertical centerline on the header above the door. By manually raising the door, determine the high point of the door's travel (see figure Figure 8B.) and using a level, transfer this measurement to the header (see figure 8C.). Draw a horizontal line, crossing the previously drawn centerline, at this point. Install the Front Mounting Bracket securely with lag screws as shown on page 9 Figure 9B. If necessary, reinforce the header with steel or wood to ensure a secure mount.



Front Mounting Bracket Must Be Installed To a Structural Support (Stud) at the Header Wall. Failure to Do So Could Cause Sensing System To Fail, Resulting in Entrapment, Injury or Death. Reinforce Header If Necessary Using A

Installation

Figure 9A.

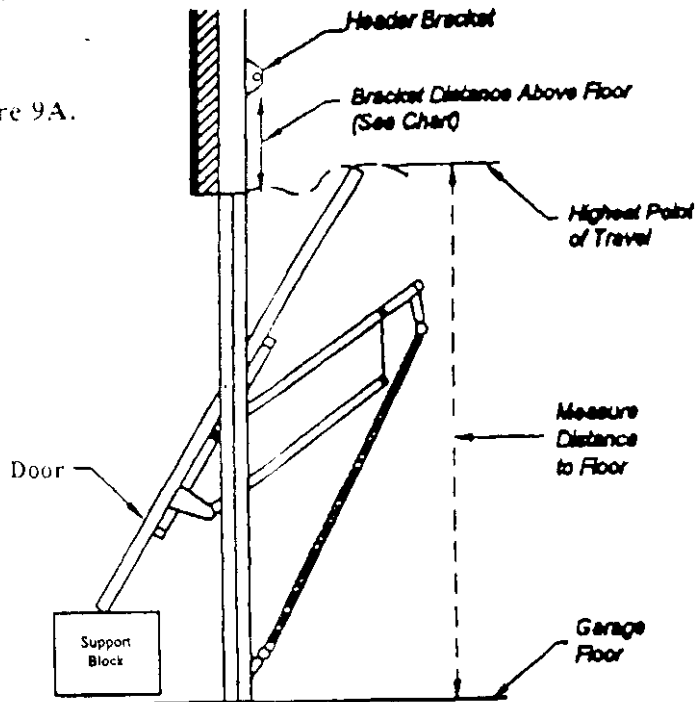

Step 1A. Mounting the Front Bracket-One Piece Door without Track. Mark a vertical centerline on the header above the door. Manually raise the door to its high arc position. Temporarily hold in this position by placing support block under door. With the door in this high arc position, measure the distance from the top of the door to the floor. See Figure 9A. Subtract the actual door height from the high arc distance to the floor. This is the high arc rise of the door. Remove block and close the door. Using the table below, draw a horizontal line at the appropriate height above the door to intersect with the vertical centerline.

High Arc Rise	High Arc Rise Horizontal Line
4 Inches	6 Inches
4 to 8 Inches	11 Inches
8 to 12 Inches	16 Inches

Mount the Front Mounting Bracket securely with lag screws as show in figure 9B. If necessary, reinforce the header with steel angle or wood to ensure a secure mount.

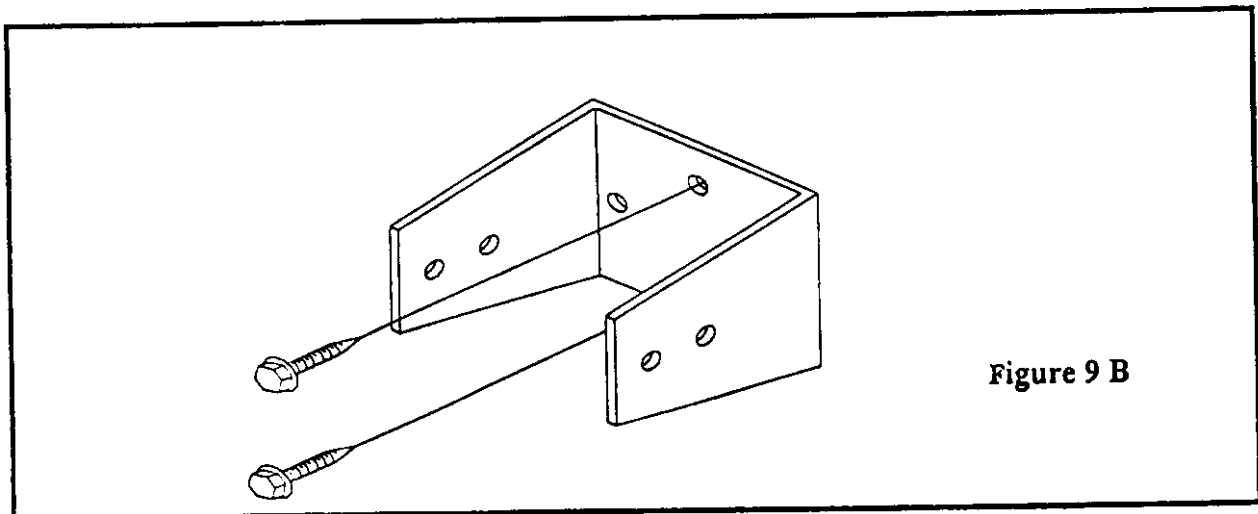

Figure 9 B

Installation

page 10

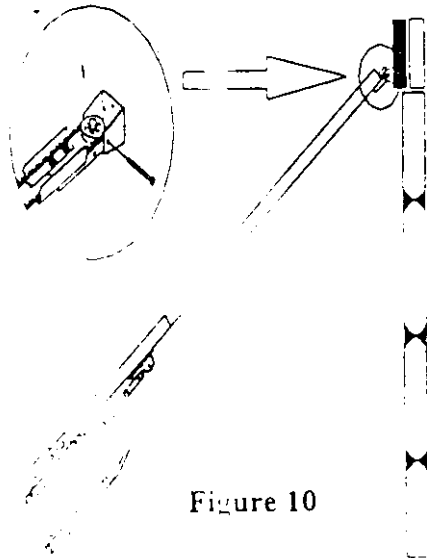

Figure 10

Step 2. Place the power unit on the floor (use cardboard packing material for protection) and raise the rail so that the Front Idler Bracket and Front Mounting Bracket align. Insert 5/16 x 2-3/4" Clevis Pin and Clip. See Figure 10A.

Step 3. Sectional Doors and One Piece Doors with Track. Raise the opener and rest the power unit on a ladder or other support. Open the door to the full open position. Allow 2" of space between the rail and the door. See Figure 10B.

Step 3A. One Piece Door without Track. Raise the opener and rest on a ladder or other support. Open the door to the high arc position. Allow 2" of space between the rail and the door (at the high arc position) as shown in illustration. The opener will be angled as shown, this is necessary for proper operation. See Figure 10C.

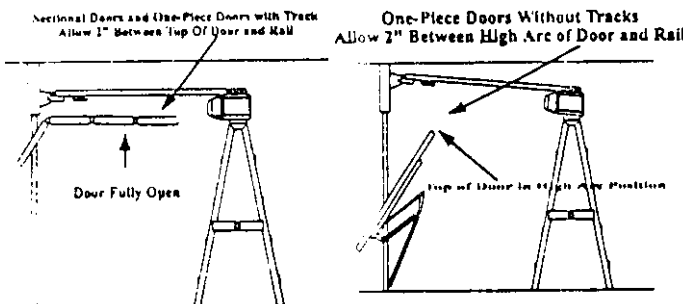

Figure 10 B.

Figure 10 C.

Note: Since the opener will be secured permanently in this position, open and close the door a few times to be sure the door does not rub on the rail and that you have allowed the proper clearance before proceeding.

Step 4. Mount Power Head to Ceiling: Since there are many different ceiling designs, all possible mounting illustrations can not be shown. Primary concern is to secure the power head to the ceiling so that operational strength, rigidity and safety are achieved. The opener must be securely fastened to a structural support of the garage. Although there are a series of mounting slots provided on the power unit, try to secure the mounting hangers to the slots closest to the front. Mounting may usually be accomplished by using standard 1-1/4" perforated steel angle available at most hardware stores or from your local garage door service person. If in doubt as to location of, and attachment to, ceiling joists, a carpenter should be contacted to provide assistance. A cross support will be necessary if power head is mounted 8" or more from the ceiling. See Figure 10D.

Fasteners Supplied: 2 ea. 5/16 - 18 x 1-7/8" Lags, 4 ea. 5/16 - 18 x 1-1/8" Hex Bolts with Lock Washers and Nuts.

Step 5. Re-check all Lags, Nuts and Bolts for Tightness.

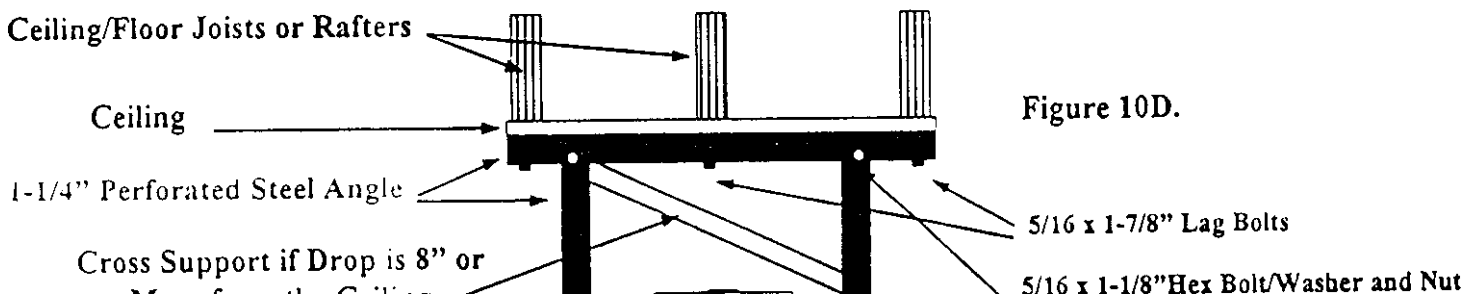
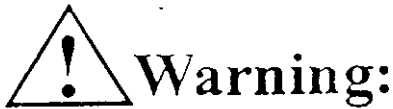

Figure 10D.



Warning:

Fiberglass, Aluminum or Lightweight Steel Doors Will Require Reinforcement before installation of door mounting brackets. Contact your door manufacturer for a reinforcement kit or instructions. Failure to properly do so may result in severe door damage.

Note: Reinforcing may affect the balance of your door. Check for proper manual operation after installation. If necessary have your door rebalanced by a qualified garage door service person.

Step 6. Door Arm, Bracket and Plate Installation: Sectional Doors and One Piece Doors with Track

Install the door mounting bracket on center and even with the top set of rollers on the door as illustrated fig. 11A. (Fastners Supplied: 2 ea. Carriage Bolts and Nuts 1/4 -18 x 2-1/4" with Flat and Lock Washers) Connect the straight door arm section (single hole section) to the trolley using a 5/16 x 1" clevis pin and clip. The door arm must pivot freely. Connect the two Door arm sections with the (2) 5/16-18 x 1-1/8" bolts, nuts and lock washers provided, adjusting the length of the door arm so that it leans toward the power unit as illustrated fig. 11C. Do not install the door arm so that it is straight up and down when the door is closed or the emergency release will not function properly. Now attach Door Arm to Trolley using 5/16" x 1" clevis pin and clip.

Figure 11A.

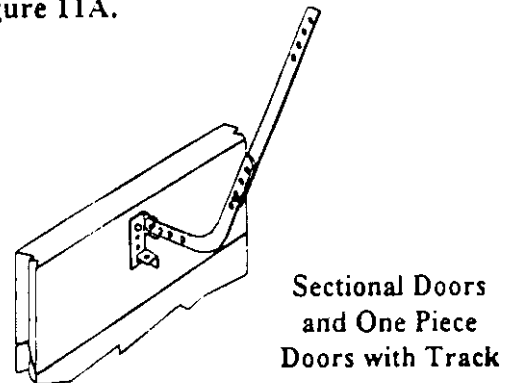
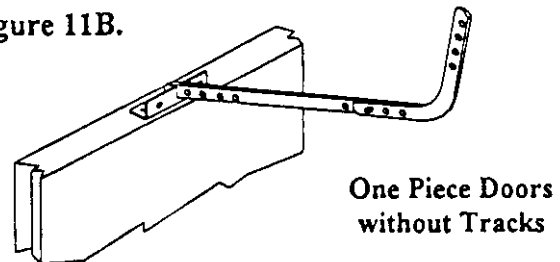
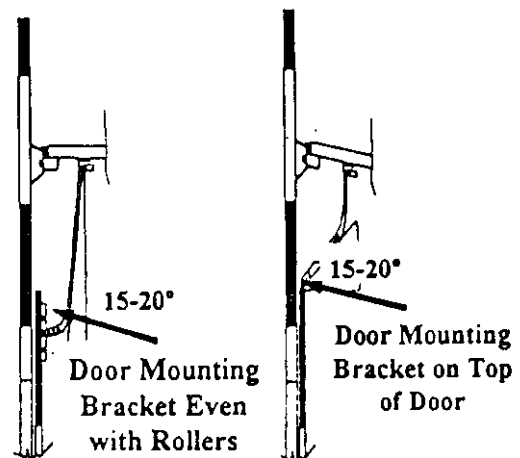

Figure 11B.



One-Piece Doors without Track

Install the door mounting bracket on the top edge of the door at center as illustrated fig. 11B. Connect the curved Door arm section (single hole end) to the trolley using a clevis pin and clip. Connect the straight door arm section (single hole end) to the door mounting bracket using a clevis pin and clip. The door arm must pivot freely. Connect the two door arm sections with the 5/16" nuts, bolts and lockwashers provided, adjust the



Installation



Use Manual Release Rope to Disengage Trolley Only. Do Not Use the Rope and Knob to Pull the Door Open or Closed

Step 7. Tie a double overhand knot in one end of the Emergency Release Rope and slip the other end through the Red Release Knob, the Release Instruction Card and the hole at the end of the Release Lever on the Trolley. (Please take time now to read and familiarize yourself with the instructions on the Emergency Release Label) fig. 12A. Tie a second double overhead knot in the free end, adjusting the Rope so that the Red Knob is 6 FT. above the floor. If the Rope must be cut, flame seal the cut end with a match or lighter to prevent fraying or unraveling.

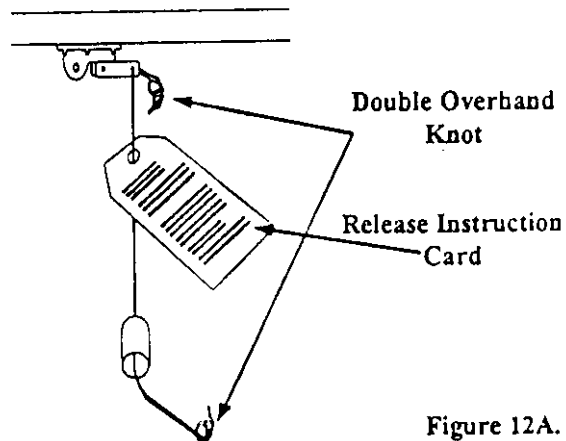

Figure 12A.

Note: The Emergency Release Mechanism is engaged by pulling the Release Knob down and towards the door, allowing the Trolley Mechanism to separate freeing the door. To re-engage simply move the Emergency Release Mechanism Lever upwards and operate the Opener using the push button or Transmitter. The two parts will automatically reconnect

Note: This operation should be attempted only when the door is fully closed. Disconnection when open or partially open can cause the door to close quickly and cause personal injury or damage to the door



WARNING:

A Child Operating the Door Controls Risks Injury - Or Death - To Himself and to Others. Do Not Allow Children to Operate Any Door Controls. Mount the Push Button at Least 5 FT from the Floor Out of Reach of Children



WARNING:

Improper Door Operation can Cause Injury or Death. Caution Label Must Be Mounted on Wall Near The Push Button. All Warnings Should Be Strictly Adhered To.

WARNING

Child can be pinned under automatic garage door. Death or serious injury can result.

- Never let child walk or run under moving door.
- Never let child use door opener controls.
- Always keep moving door in sight.
- If person is pinned, push control button or use emergency release.
- Test door opener monthly:

Refer to your owner's manual.
Place one-inch object (or 2x4 laid flat) on floor.
If door fails to reverse on contact, adjust opener.
If opener still fails to reverse door, repair or replace opener.

Do not remove or paint over this label, which is required for child's safety.
(at least 5 feet above floor)

©1999 The Safety Council For America, Garage Door Opener Safety

Figure 12 B.

Installation

page 13

Step 8: Installing the Standard Wall Push Button. Remove about 1/4" of insulation from both ends of the 2 strand low voltage bell wire. Connect one end to both screw terminals on the back of push button. Select a convenient place near an access door, 5 ft from the floor and out of reach of children, for mounting. (2) 1-1/2" Screws and dry wall anchors supplied.) Install the Caution Label fig.12B page 12, near this installation. Run bell wire up the wall and across to the opener. Secure with insulated staples. Attach to Terminals B & C fig. 13B.

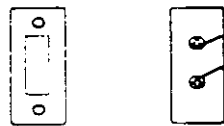

Figure 13A.

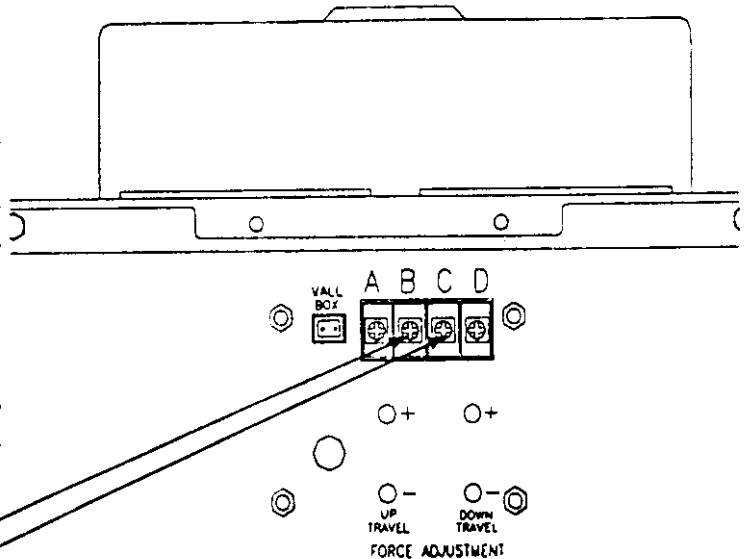

Figure 13B.

! WARNING:

Installation & Wiring Must Be in Compliance with Local Electrical and Building Codes. Operation at other than 120V60Hz Will Cause Opener Malfunction and Damage.

Step 9. Opener Must be permanently wired or plugged into a grounded 3-prong receptacle wire according to local codes, within 3 Ft of the Power Unit. A GFI Type Receptacle 14 Ga. or heavier is Recommended. Do Not Use a 2-prong adapter or Extension Cord. If Local Code requires permanent wiring, a GFI Type is recommended to protect the line. Contact a Licensed Electrician to install required circuit and to direct wire the Opener.

Step 10. Install a 75 watt Rough Service Bulb (available at most hardware stores) firmly in the light socket. Light bulbs in Door Openers are subject to vibration during normal operation which may shorten their life span. Fit Light Lens Cover and snap into place.

Installation

page 14

Step-11: Setting Personal Transmitter Access Codes .

Your Opener contains a built in Receiver

To set Receiver: With a pointed object push the button shown in figure 14B. The Opener Light will begin flashing and continue to flash for 10 seconds. During this time press the round button on your transmitter (figure 14 A.) until the light stops flashing and stays on. If the light does not stop flashing and stay on or if the light stops flashing and goes out your code is not set. Start the process again. Once your code is set the light will stay on for 4-1/2 minutes .

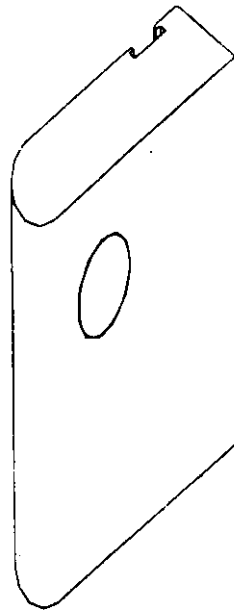

Figure 14A.

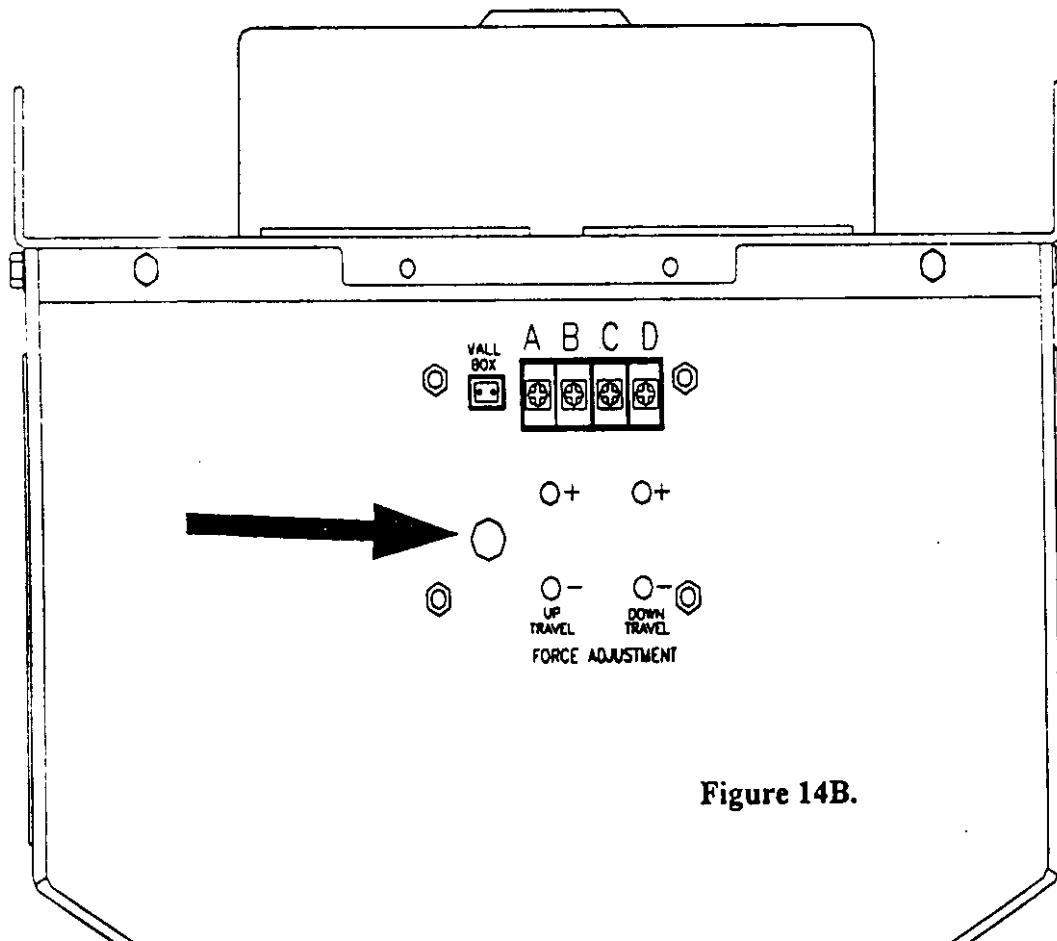

Figure 14B.

Your Garage Door opener is supplied with an Auxilliary Entrapment System. Please Read The Following Carefully.



Important: The Opener will not operate until the "Silent Guard" Photoeyesystem is installed, properly aligned and connected

The Beam must not be obstructed in any way. If obstructed the door can only be closed by applying constant pressure to the wall button only.

The Transmitter cannot be used to close the door.



Warning:

A Garage Door without an Auxiliary Entrapment Protection System Poses a Threat of Injury or Even Death. Install the Photoeyesystem No Higher than 4"- 6" Above the Floor To Reduce All Risk to Children



Warning:

Risk of Entrapment. Disconnect Power to the Opener Before and During Installation of This Accessory. Do Not Reconnect Power to Opener Until Instructed To Do So. Ensure Doorway is Clear Before Starting Testing of Unit.

Step 12: Installation of "Silent Guard" Photoeyesystem.

- A. Mark the position of the "Silent Guard" Photoeyesystem as follows: Mark a line on the left and right door jamb (as close as possible to the door track) 4" and 6" above the floor (See Figure 17A). The top mark is the maximum height and the bottom the minimum height that the "Silent Guard" Photoeyesystem may be placed.
- B. Mounting the "Silent Guard" Photoeyesystem "L" Brackets:
 1. Remove the two "L" mounting brackets, the Receiver Unit (with red LED and two (2) wires) and the Transmitter Unit (Single Wire) from the package.
 2. Using either the transmitter or receiver (LED up towards the ceiling) temporarily attach to the "L" bracket with the two (2) (NeedSize) Phillips Head provided, hand tighten only, and move the Unit in between the limit marks on the door jamb (Step 12A). Continue to move the assembly within the limit marks until it clears the door hardware. Check to ensure the Window on the front of the Photoeyesystem Unit is within the limit marks on the door jamb.
 3. Place a mark in the center of the lag screw elongated mounting hole. Measure its position and place a similar mark on the opposite door jamb. Remove Receiver/Transmitter from "L" Bracket. Temporarily mount the bracket to the jamb with the 1" flat head nail (provided) using the small hole above the slot. Using the 5/16"-18 x 1-7/8" lag screws (provided), permanently mount the "L" bracket to both door jambs.

Installation of Photoeyesystem Continued.

C. Connecting the "Silent Guard" Photoeyesystem

1. Re-attach the transmitter and receiver to their "L" mounting brackets (Hand Tighten Only)
2. Run the interconnect White wire pair up and around the garage door jamb between the transmitter and receiver "L" mounting brackets. See page 17 Note: Wire can be cut, trim to length (leave about 12" of extra wire) and reattached using wire nuts provided or the excess wire may be just coiled and left. Please make sure that wire is free and will not be caught in the door track.
3. Run a the second interconnect wire pair from the receiver position (unit with LED light in front) back to the rear of the opener. NOTE: leave about 12" of extra wire at the opener end.
4. Strip approximately 1/4" from each wire end.
5. Connect the interconnect wire pair from the receiver to the opener terminals marked A & B as follows: Solid Black Wire to Terminal B, Black Wire with White Marks to Terminal A. (See Figure 17 B.)

D. Final Alignment and Test

1. Connect the power to the opener. The light on the Opener will flash for 5 seconds indicating power has been restored to the unit. Keep a portable transmitter with you to control the opener.
2. Loosen the bolt and nut on the transmitter unit bracket and adjust the bracket to be parallel with the garage door. Tighten the carriage bolt and nut enough to temporarily hold the unit in place.
3. Loosen the carriage bolt and nut on the receiver unit "L" bracket and move the receiver from left to right and up and down until the LED lights in the middle of each arc. NOTE: Move the unit very slowly until the assembly sets-up. There can be as much as a five second delay before the LED indicates proper alignment.
4. As soon as proper alignment is achieved tighten the carriage bolt and nut enough to temporarily hold the unit in place.
5. Place your hand or a solid object one foot in front of the transmitter or receiver. The red LED should go OFF and remain Off until the object is removed. NOTE: There may be a slight delay in returning to normal depending upon how long the photoeyesystem was blocked
6. Move to the center of the door. Make sure the red LED light is ON. Move your hand or a solid object slowly through the beam. The LED should go OFF and then ON. If not, check alignment of the system
7. At this time set the down limit Page 18 and reversing system adjustment Page 19 of the opener. It is very important that the Opener's inherent features operate as intended before completing the photoeyesystem tests.
8. Place an object at least 6" high on the floor at the center of the door. Now, attempt to close the door. The door should not close from the portable transmitter, but will close with constant pressure from the wall button
9. Remove the obstruction from the photoeyesystem beam's path. Close the door. Towards the bottom of the door's downward travel, Carefully move your hand across the path of the beam at the center of the door. The Door should stop, pause for approximately 1-1/2 seconds and Reopen. Retest, breaking the beam one foot in front of both the transmitter and receiver unit while the door is moving downward. The door MUST STOP and OPEN each time. If not, re-align the photoeyesystem until proper operation is obtained.
10. Tighten all mounting screws, nuts and bolts.



Installation

Installation of Photoeyesystem Continued.

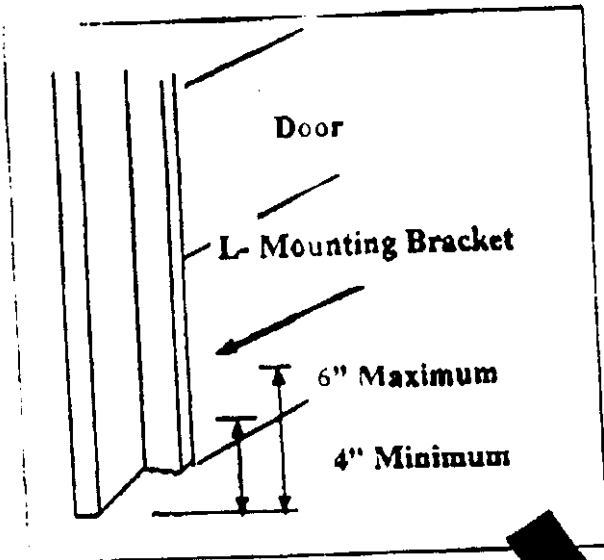

Figure 17A.

Figure 17B.

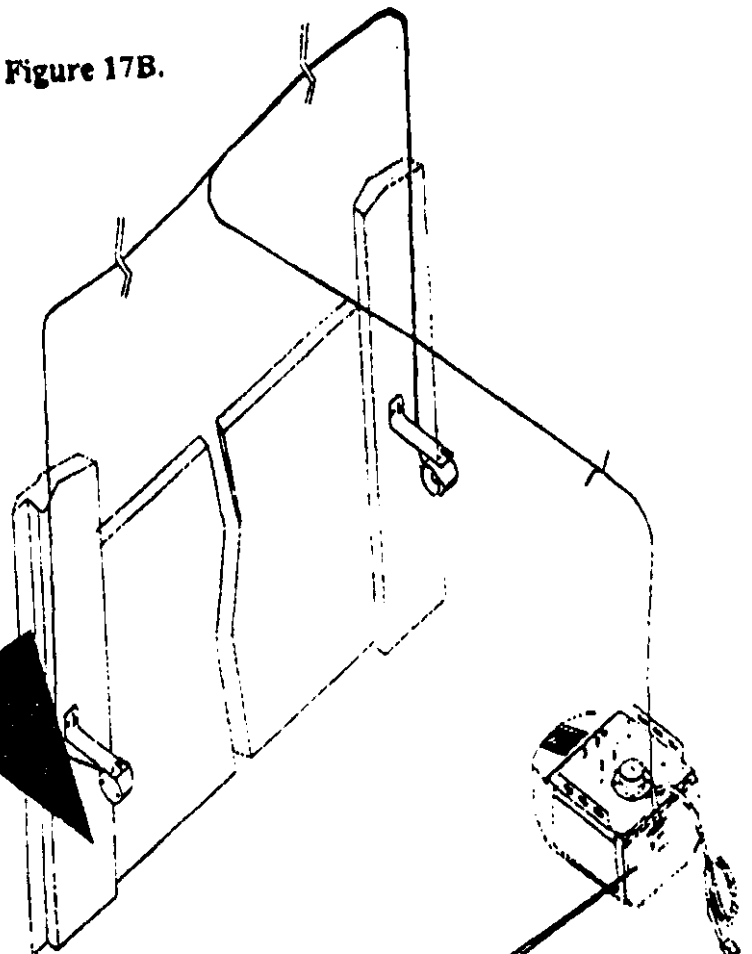
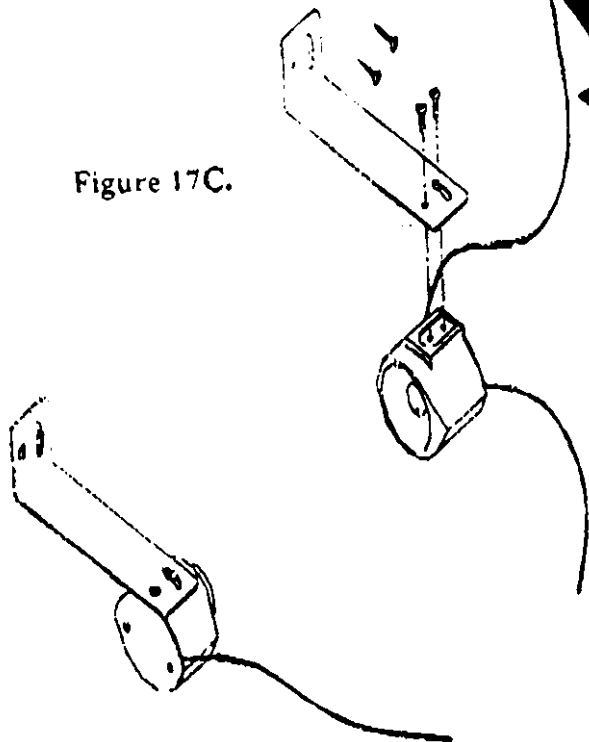
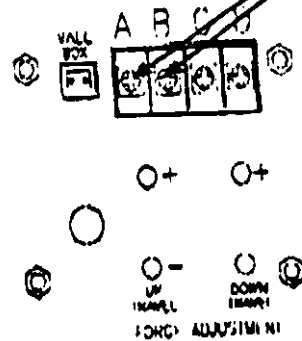

Figure 17C.



Solid Black Wire : Terminal B
Black and White Wire: Terminal A



Adjustment



Warning:

If Limits are not adjusted properly, the emergency release mechanism may not work properly and door operation could result in door damage or serious injury.

NOTE: It is now necessary to turn on the power in order to run the opener to check limit settings. Before doing so, ensure that all mounting hardware is installed and has been properly tightened, that all electrical connections are per local code requirements. Double Check that all ropes have been removed and that the doorway is clear.

Up and Down Limits:

Limit adjustments settings regulate the total amount of distance the door will travel while opening and/or closing

Setting the Up Down Limits.

Note: Run the Opener through a complete travel cycle after each adjustment.

NOTE: Repeated Operation of the Opener may cause the motor to Overheat and the Thermal Overload Protection System will shut off the Opener. Please wait approximately 15 minutes for the Opener to cool down and automatically reset.

If the door opens completely and closes completely without reversing: No adjustment is necessary.

If the door does not open completely but opens at least five feet: Increase Up travel by turning UP LIMIT screw Clockwise

If the door does not open five feet: Adjust Up FORCE/SENSITIVITY Setting Page 19.

If Door does not close completely: Increase Down travel by turning DOWN LIMIT screw Counter-Clockwise

If Door reverses in full closed position: Decrease Down travel by turning DOWN LIMIT screw Clockwise

If Door Continues to Reverse: Disconnect Door from Opener use manual release. Check for binding while working door manually. If door binds or is out of balance call a qualified garage door service person. If no binding is found and balance seems correct adjust FORCE/SENSITIVITY Setting Page 19.

NOTE:
1 Full Turn will equal approximately (3-1/2") three and one half inches of door travel

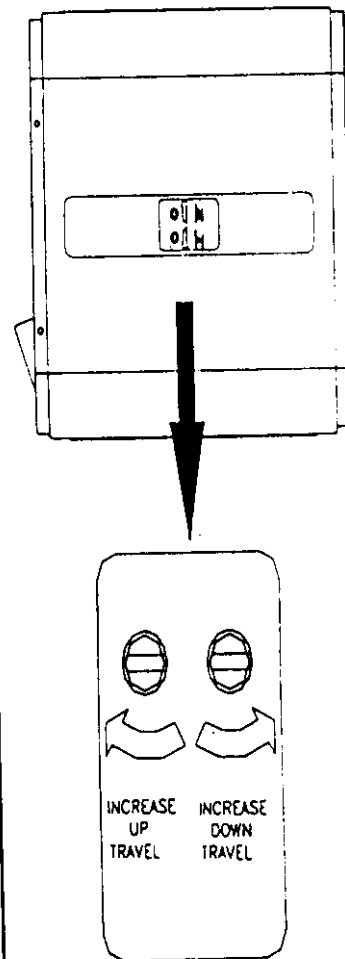

Adjustment

Force/Sensitivity Adjustment:

! Warning:

Improper Adjustment of Sensitivity System Force Could Cause Entrapment, Injury or Death. Set Adjust For Just Enough Force To Operate The Door Reliably, But No Stronger. Do Not Over-Adjust Force/Sensitivity System To Compensate For A Poorly Working, Sticking or Binding Door (Contact a qualified Garage Door Service Person to Correct any binding, sticking and /or other door problems).

Force/Sensitivity

Adjustment Controls are located on the Back Panel of the Opener(See Figure 19A). Adjustment Settings regulate the amount of pressure required to open and close the door.

NOTE: If the Adjustments are set too light constant reversal while closing and or stopping while opening may occur. Weather conditions may also affect the operation of the door requiring occasional adjustments as needed

Note: There are 12 Gradients each per force setting. When either the maximum or minimum setting is reached the light will flash for 5 seconds .

Force/Sensitivity Adjustment Test: Down/Close If Door reverses while closing - increase

Down Pressure by pushing the Down (+) button 1 time. After each adjustment, test Down Sensitivity by grasping the door handle or by holding door at the bottom. The Door should reverse. If the Door is difficult to hold and reverse, decrease down (-) pressure until it reverses with the least amount of pressure. If Door Doesn't open at least 5 FT. Increase UP (+)Force, 1 push at a time , till door opens to full open position. After each adjustment run the Opener through a full cycle. For Safety the Force settings should always be set at the least amount necessary to run the door

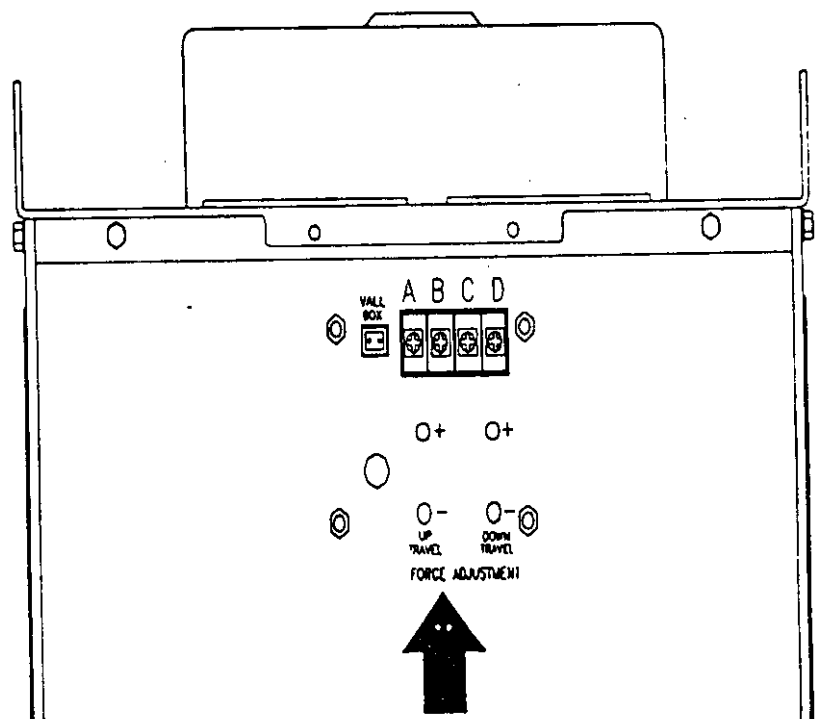

Figure 19 A.

Adjustments

page 20

Testing the Safety Reverse System.

⚠ Warning:

Failure to Test Reversing System Could Result in Death or Serious Injury. Test This System Once A Month.

To test the Opener's Reversing Feature at floor level, place a solid object 1-1/2" thick on the ground so that the center of the door will contact it. Close the Door. If the Down Force Adjustments are Correct, the door will reverse within one and a half (1-1/2) seconds of contacting the object and travel to the Full Open Position. Light will also start flashing and continue to flash for 4-1/2 minutes. If this does not occur, re check Limit Adjustments Page 18 and Force/Sensitivity Adjustments Page 19.

Note: Any time any adjustments are made to Limits or Sensitivity, You Must Retest the opener for the Reversing Feature at Floor Level as outlined above.

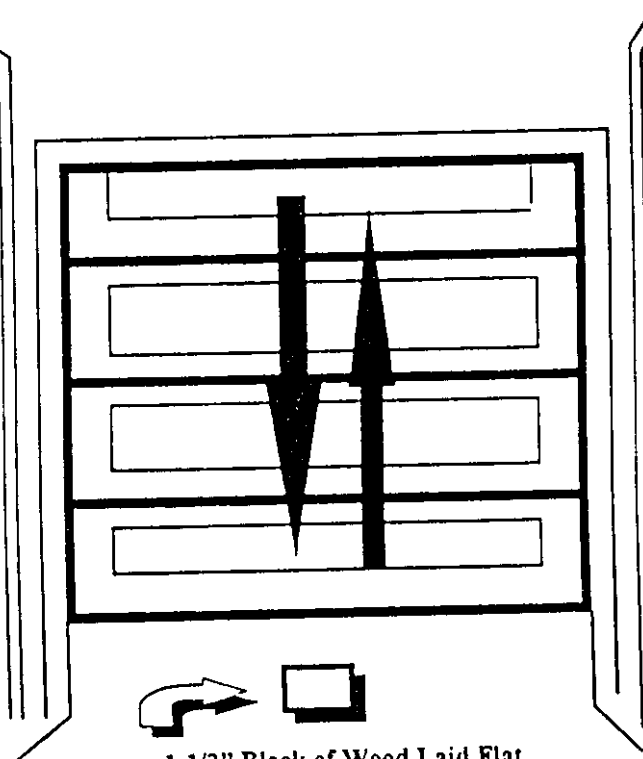

⚠ Warning:

The Sensitivity System Reversing Test Should Be Performed Monthly to Ensure That This Important System Remains in Proper Adjustment

Adjustments

page 21

Testing the Photoeyesystem



Warning:

A Damaged or Malfunctioning Photoeyesystem Could Enable a Garage Door to Close on People or Property, Causing Serious Injury or Death. Perform this Test Monthly to Ensure Proper Operation

Start the door down towards the close direction and then place an obstacle approximately 8" high by 12" wide in the path of the beam. The Red Pilot Light on the "Silent Guard "

Photoeyesystem should go off. The door should stop for 1-1/2 seconds and reverse to the full open position. The Opener light will also begin flashing and continue to flash for 4-1/2 minutes. If the door is moving up and the beam is broken, the door will continue up to full open and the light will begin flashing and continue to flash for 4-1/2 minutes.

With the door fully open and at rest, place the obstacle in the path of the beam once again. Activate the Wall Push Button. The Opener will revert to and remain in the safety Push And Hold Operation for close travel. See Page 17.

NOTE: If the Garage Door Travels More Than One Inch in a Downward Path After Releasing the Button, the "Silent Guard" Photoeyesystem is Malfunctioning. Check All Electrical Connections and Alignment of the Photoeyesystem.

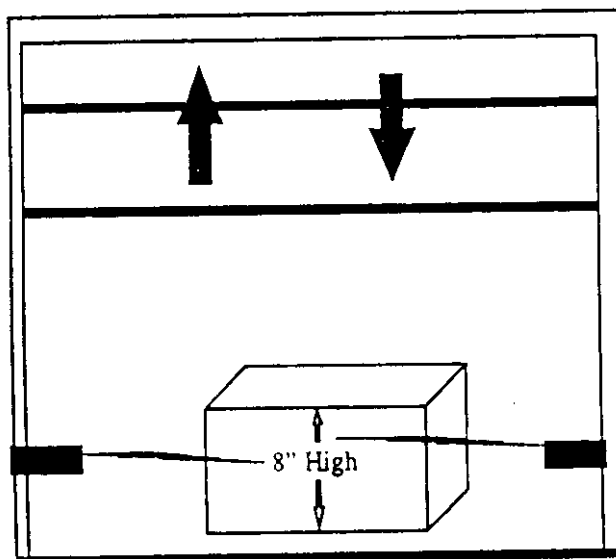

Final Installation

page 22

Make Sure That:

1. The front and rear mounts for the opener are sound and secure and the rail is positioned correctly above the high arc of the door and that the opener is positioned over the door action centerline.

2. For sectional doors and one-piece doors with tracks, the position of the door arm with the opener closed, is such that its connecting point on the trolley is 5" to 8" behind its connecting point on the door bracket. The door arm should never be perfectly vertical when the door is in the closed position

For one piece doors without tracks, the position of the door arm, with the door closed, is such that its connecting point on the trolley is 20" to 22" behind its connecting point on the door bracket. The straight portion of the door arm should be at an angle of 15-20 degrees with respect to the floor when the door is closed.

3. The emergency release knob and cord are secured to the emergency release lever on the trolley. The knob is located 6 ft above the floor and requires no more than 50 lbs. pull to actuate. The trolley and release mechanism are properly lubricated.

4. The standard lighted wall push button is in such a position and at such a height that it can only be actuated by an adult. The caution label is prominently displayed next to the push button.

5. All wiring is correct to code. There is ground continuity in the supply. The ground prong on the power cord is intact.

6. All ropes have been removed from the door. The door moves freely without binding when operated manually. The door is correctly balanced and lubricated. All door hardware is secure and sound. The sensitivity has been adjusted to minimum force. The appropriate warning sticker has been affixed to the door.

7. The door reverses on obstructions to within 1" of the floor. The floor beneath the closed door provides uniform contact.

8. The plastic envelop with this manual is attached to the wall near the pushbutton.

9. On doors with extension type springs, safety restraint cables have been installed through the springs

10. There is GFI protection on the power line to the opener

Troubleshooting

Symptoms	Probable Cause/Solution	Symptoms	Probable Cause/Solution
Opener does not work	1, 2, 3, 4, 5, 6, 7, 15	Opener opens and closes by itself	3, 18
Opener Operates from push button but not radio controls	8, 9, 21, 12	Light will not come on	19, 7
Stops before reaching full Open or Closed position	3, 5, 6, 10, 11, 13, 14	Light will not turn off after opener runs	7
Reverses before reaching Full Close position	6, 11, 14	Transmitter has short range	8, 21, 12, 20
Reverses after door closes and contacts floor	16, 17		
Probable Cause	Solution	Probable Cause	Solution
1. Mechanical lock engaged	Remove all locks	12. Defective transmitter or receiver	Contact your local dealer
2. 120 volt power not present at outlet	Check wall switches, fuse box, circuit breaker, etc.	13. Up sensitivity force improperly adjusted	Adjust Sensitivity See Page 19
3. Broken or Shorted Push Button, wiring or radio receiver	Remove push button wiring and radio receiver from the terminal strip on the back of the operator. Activate opener by connecting terminals E & F with a test wire. If opener runs, reconnect each item one at a time to find defective circuit. Replace	14. Down sensitivity force improperly adjusted	Adjust sensitivity See Page 19
4. Motor Control Board Fault	Unplug Opener, then reconnect	15. Bottom of door frozen to ground	Activate Emergency Release. Remove Ice.
5. Motor Thermal Overload Activated	Wait 15-30 minutes for motor to cool	16. Ice and Snow buildup under door	Remove
6. Door jammed because of broken or poorly adjusted springs.	Ensure that the door is in the closed position. Activate the emergency release mechanism. If opener runs without door attached problem lies with door binding or balance, Call a professional door service person for repairs	17. Floor Risen or Sank because of weather	Reset Down Limit See Page 18
7. Defective motor controls	Contact your local dealer	18. Someone in area with identical code	Reset all transmitter and receiver codes See page 14
8. Weak Battery in Transmitter	Replace Battery	19. Defective or burned out light bulb	Replace with Rough Service Bulb 75W Max.
9. Radio transmitter coding mismatched	Reset transmitter See page 14.	20. Radio Receiver not receiving signal	Ensure antenna wire from opener is pointing straight down towards the floor
10. Limits not set properly	Re Set Limits See page 18	21. Transmitter location in the car	Ensure transmitter is clipped to sun visor. If it is clipped to

After The Installation

page 24

1. Never permit children to play with or operate the garage door opener either from the wall station or the remote controls. Keep radio transmitter locked in the car. Misuse of the pushbutton or transmitter could result in serious injury or even death.
2. Open the garage door with the remote controls only when the garage door is fully visible to you and clear of all obstructions. The garage door should be kept in sight until it is completely open or closed and you are certain that the garage door opener has shut off.
3. Attempting to exit the garage through the garage door opening, while the door is in motion, is a very dangerous activity that could result in serious injury or even death.
4. Children and pets should always be clear of the door opening while the garage door is in motion.
5. Check the safety reverse mechanism at least once a month to make sure that it will reverse with the minimum amount of force. Also check to be sure that the door will reverse within 1-1/2" of the floor . See page 20
6. Check the manual operation of your garage door at least every 90 days to be sure that it is operating smoothly and does not bind or stick. Tighten all bolts on the door and visually check all hardware including springs for wear or damage. **⚠ CAUTION:** If service is needed contact your local garage door service person.
7. Do not decrease the safety reversing sensitivity mechanism to overcome a damaged or poorly operating door. This will adversely affect the operation of the safety reverse mechanism which could result in damage to the door, personal injury or even death.
⚠ CAUTION: Never operate the door opener if the reversing mechanism is not functioning properly.
8. Whenever possible, the manual disconnect should only be used when the door is fully closed. **⚠ CAUTION:** Extreme care must be taken whenever the disconnect cord is pulled with the door partially open. Weak or broken springs may allow the door to fall rapidly resulting in property damage, personal injury or death. If a broken spring is evident, contact your local garage door service person immediately before disconnecting the door from the opener. Never attempt servicing a broken spring.
9. Always disconnect electrical power supply to the opener when performing any maintenance or service to the opener or garage door. Failure to do so could result in electrical shock, property damage, personal injury or death.
10. If any damage to any mechanical or structural component of the opener is observed, discontinue use and contact your local garage door service person immediately.

Wiring Schematic

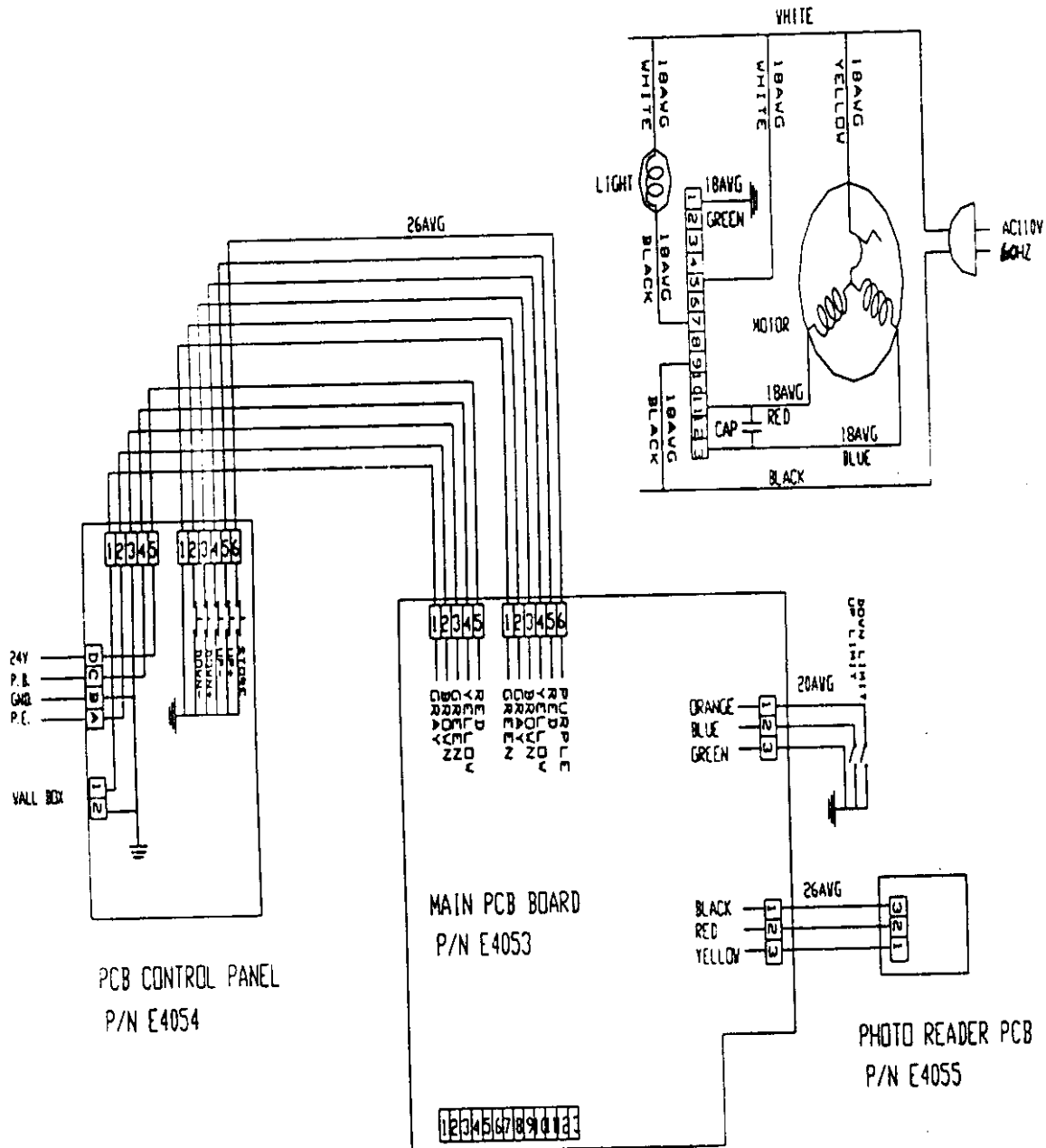

Rail and Hardware Parts List page 27

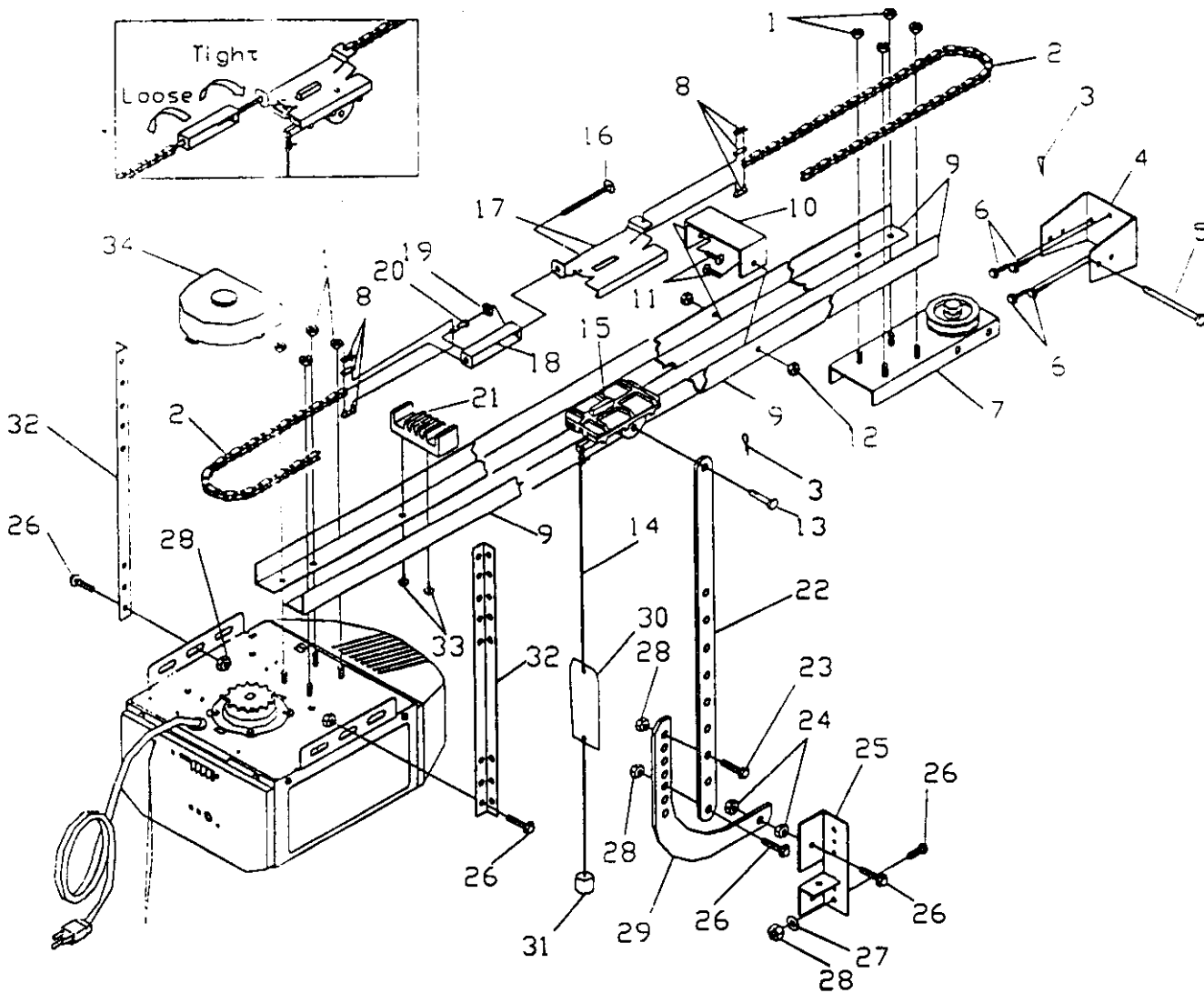

B-1	Nut - 5/16"	B-18	Chain Connector
B-2	Chain	B-19	Nut - 1/4" -20
B-3	Clevis Clip	B-20	Chain Pin
B-4	Header Bracket	B-21	Stop
B-5	Clevis Pin	B-22	Straight Door Arm
B-6	Lag Screw - 5/16"	B-23	Bolt - 1/4" -20
B-7	Return Pulley Assembly	B-24	Door Bracket Nut - 1/4" -20
B-8	Chain Master Link	B-25	Door Bracket
B-9	"L" Rail	B-26	Carriage Bolt - 1/4" -20
B-10	Rail Bracket	B-26A	Door Bracket Bolt
B-11	Screw	B-27	Flat Washer
B-12	Nut	B-28	Nut - 5/16" -18
B-13	Clevis Pin	B-29	Curved Door Arm
B-14	Emergency Pull Rope (Red)	B-30	Emergency Pull Rope Warning Tag (Red)
B-15	Trolley Assembly	B-31	Emergency Pull Rope Knob
B-16	Adjusting Screws	B-33	Stop Screws

Limited Warranty

Residential Garage Door Opener and Remote Control System

_____ warrants all components of its residential garage door openers against defects in material and/or workmanship to the original purchaser. Any parts, power unit, remote control system or complete garage door opener that fails during the warranty period will be repaired or replaced in accordance with the following provisions:

Motor: Warranted to be free from any defect in materials and/or workmanship for a period of 5 years from date of purchase.

Electronics: Warranted to be free from any defect in material and/or workmanship for a period of 3 years from date of purchase.

All other Components including Power Train/Mechanicals: Warranted to be free from any defect in materials and/or workmanship for a period of 1 year from date of purchase.

If within the stated warranty period it is determined that a component is defective or that a component failed as a result of poor workmanship _____ will repair or replace (_____ option) the component at no cost to the owner. Defective parts will be repaired or replaced with new or factory rebuilt parts.

To make claim under this warranty contact _____ you will be instructed on how to proceed regarding replacement and repair.

This warranty is void when any component part fails because of damage from improper use, handling, faulty installation, faulty connection to an improper power source, failure to properly maintain, modification of unit, use other than on residential garage door and damage from fire, water or acts of God.

This warranty excludes all other warranties, expressed or implied, including any warranty of merchantability. _____ shall not be liable for consequential or incidental damages that may arise from any defect or failure of the garage door opener. No person or representative is authorized to extend, modify or change the provisions of this warranty in connection with the sale, installation or use of this product.

All labor charges for removal and re-installation of the door opener are the responsibility of the owner. _____ shall not be responsible for the cost of any part, labor or service charge which is performed by any other person or entity at any time.

Batteries are not included in the warranty program.

Some states do not allow the exclusion or limitation of consequential or incidental damages. This limitation is not valid in jurisdictions which do not allow limitation of incidental or consequential damages or limitation of warranty periods.

This warranty gives you specific legal rights and you may also have other rights which vary from state to state.

THIS DEVICE COMPLIES WITH PART 15 OF THE FCC RULES. OPERATION IS SUBJECT TO THE FOLLOWING TWO CONDITIONS: (1) THIS DEVICE MAY NOT CAUSE HARMFUL INTERFERENCE AND (2) THIS DEVICE MUST ACCEPT ANY INTERFERENCE RECEIVED, INCLUDING INTERFERENCE THAT MAY CAUSE UNDESIRABLE OPERATION.