

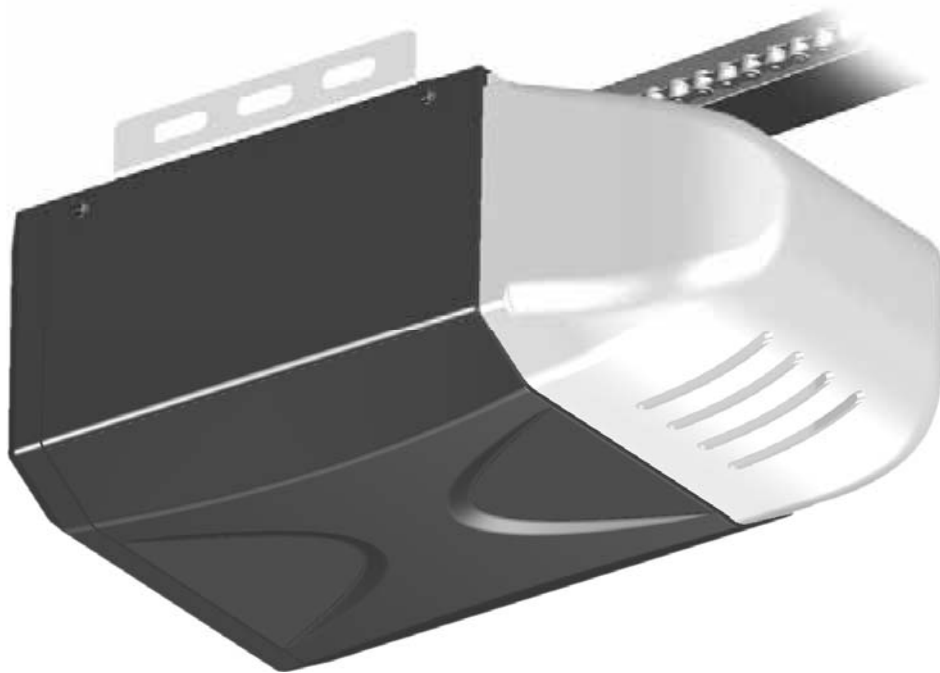

MODEL 2211-L
CORE SERIES 1/2HP

WARNING:

To reduce the risk of injury to persons - Use this opener only with Residential Sectional Garage doors.



Owner's Manual

- Please read and understand this manual and safety instructions carefully before installation.
- The Opener WILL NOT CLOSE until the Photo Eye Safety System is properly installed and aligned.
- REGULARLY CHECK and TEST the Opener according to the safety label to ENSURE SAFE OPERATION.
- Retain this manual for future reference.

Serial # _____ **Date Installed** ____ / ____ / ____

Located on the bar code label on top of your opener.

The illustrations used in this instruction manual may differ from the actual product you have purchased.

Table of Contents

Introduction

Symbols and Icons	1
Inventory	2
Read and Follow These Important Safety Instructions	3

Preparation / Door Balance Test	4
Tools Required	4

Assembly

T-rail Assembly and Tensioning	5
Mounting Header Bracket	6

Installation

Attaching the Opener Assembly to Header Bracket	7
Mounting Door Bracket	7
Mounting Opener to Ceiling	8
Attaching Door Arms	9
Installing Light and Emergency Release Handle	10

Wiring

Wiring Instructions	11
Connecting Photo Eye Safety System	12
Connecting Push Button	13
Connecting Power	14

Adjustment

Aligning the Photo Eye Safety System	14
Travel Limit Adjustment	15
Force Adjustment	16
Final Adjustment and Testing	17

Operation

Programming Remote Controls* (OPTIONAL)	18
Operating the Opener	19-20
Maintenance	21
Troubleshooting	21

Repair Parts and Service

Installation and Accessory Parts	22
Opener Assembly parts	23

Warranty	24
----------	----

Symbols and Icons



WARNING

READ WARNINGS CAREFULLY to prevent **SERIOUS INJURY** or **DEATH** caused by electrocution or mechanical hazard.



DO NOT connect power



Please connect power

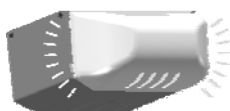

Courtesy light turns on/flashes with audible 'click'.
(If light bulb is not installed, 'click' represents the light)

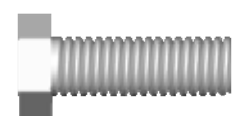

Installation hardware

Inventory

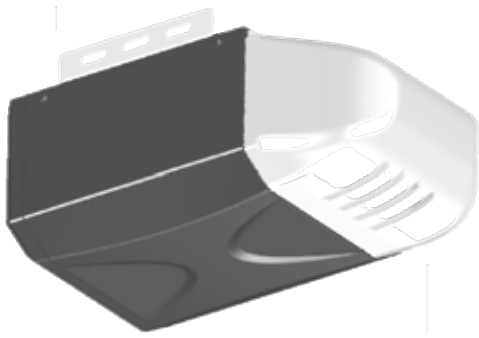

Opener Unit + Lamp Dome
(Light bulb are not included)

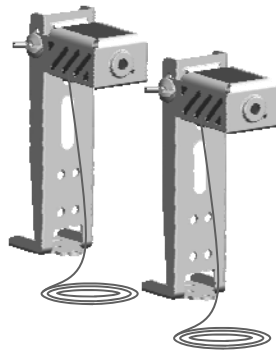
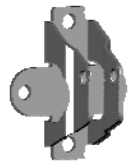

Photo Eye Safety System



Emergency Release Handle + Rope



Door Bracket

Standard Door Control



Remote Control



Push Button

Door Control included in some models



3-FDCC



1-FDCC



Screw #6 x 1" x 2



Drywall Anchor x 2



Literature + Safety Labels

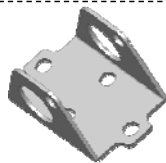

Header Bracket



Clevis Pin Long x1
5/16" x 2-1/4"



Hitch Pin — Locking Clevis Pins x1



Door Arms

INSTALLATION HARDWARE, LOCATED IN HARDWARE BAG (SHOWN IN ACTUAL SIZE 1:1)



Clevis Pin — Door arms
5/16" x 1" x 2

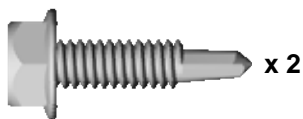

Lag Screw 1/4" x 1" x 2
— Door Bracket

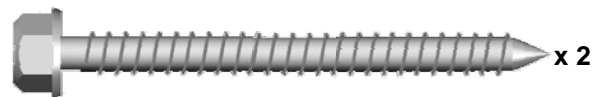

Lag Screw 5/16" x 2 1/2" x 2
— Header Bracket / Mounting Opener



Hitch Pin — Locking Clevis Pins x 2

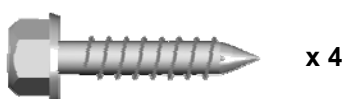

Lag Screw 1/4" x 1" x 4
— Photo Eye System

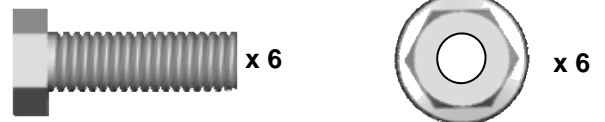

Bolt 5/16" -18 x 1" x 6
— Door arms / Mounting Opener

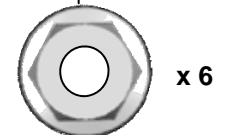

5/16" Flange Nut x 6



Emergency Release Handle + Rope x 1

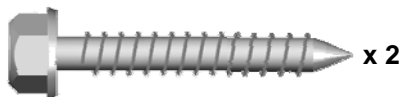

Lag Screw 5/16" x 1-5/8" x 2
— Door Bracket / Mounting Opener

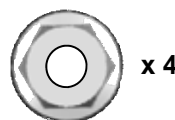

Flange Nut 1/4" -20 x 4



Hexagonal Screw #10 - 24 x 1/2" x 1



Washer #10 x 1



Spring Washer #10 x 1

T-rail Assembly

IMPORTANT INSTALLATION INSTRUCTIONS

WARNING —

To reduce the risk of severe injury or death:

1. READ AND FOLLOW ALL INSTALLATION INSTRUCTIONS.
2. Install only on a properly balanced garage door. An improperly balanced door has the potential to inflict severe injury. Have a qualified service person make repairs to cables, spring assemblies, and other hardware before installing the opener.
3. Remove all ropes and remove or make inoperative all locks connected to the garage door before installing opener.
4. Where possible, install the door opener 7 feet or more above the floor. For products having an emergency release, mount the emergency release within reach, but at least 6 feet above the floor and avoiding contact with vehicles to avoid accidental release.
5. Do not connect the opener to source of power until instructed to do so.
6. Locate the control button: (a) within sight of door, (b) at a minimum height of 5 feet so small children are not able to reach it, and (c) away from all moving parts of the door.
7. Install the Entrapment Warning Label next to the wall-mount control button in a prominent location. In case the adhesive does not adhere on the surface, the label should be attached to the surface by mechanical means.



Entrapment Warning Label—Permanent attach next to wall-mounted control button

8. After installing the opener, the door must reverse when it contacts a 1-1/2-inch high object (or a 2 by 4 board laid flat) on the floor.

IMPORTANT SAFETY INSTRUCTIONS

WARNING —

To reduce the risk of severe injury or death:

1. READ AND FOLLOW ALL INSTRUCTIONS.
2. Never let children operate or play with door controls. Keep the remote control away from children.
3. Always keep the moving door in sight and away from people and objects until it is completely closed. **NO ONE SHOULD CROSS THE PATH OF THE MOVING DOOR.**
4. **NEVER GO UNDER A STOPPED, PARTIALLY OPEN DOOR.**
5. Test door opener monthly. The garage door **MUST** reverse on contact with a 1-1/2-inch high object (or a 2 by 4 board laid flat) on the floor. After adjusting either the force or the limit of travel, retest the door opener. Failure to adjust the opener properly increases the risk of severe injury or death.
6. Use the emergency release only when the door is closed. Use caution when using this release with the door open. Weak or broken springs are capable of increasing the rate of door closure and increasing the risk of severe injury or death.
7. **KEEP GARAGE DOORS PROPERLY BALANCED.** See owner's manual. An improperly balanced door increases the risk of severe injury or death. Have a qualified service person make repairs to cables, spring assemblies, and other hardware.

SAVE THESE INSTRUCTIONS.

Preparation

WARNING

To prevent **SERIOUS INJURY** or **DEATH**:

- Before beginning installation of the Opener please complete the following test to ensure that your door is balanced and in good working condition.
- A poorly balanced door can cause serious injury and damage to the Opener.
- Always have a qualified garage door service technician make any required adjustments and/or repairs to your door before proceeding with installation.
- **DISABLE ALL LOCKS** and **REMOVE ALL ROPES** connected to the garage door **BEFORE** installing and/or operating the Opener.



To prevent damage to the door and Opener:

- **DO NOT** connect power until instructed.
- Operate this Opener with AC 120V/60Hz power supply **ONLY**.

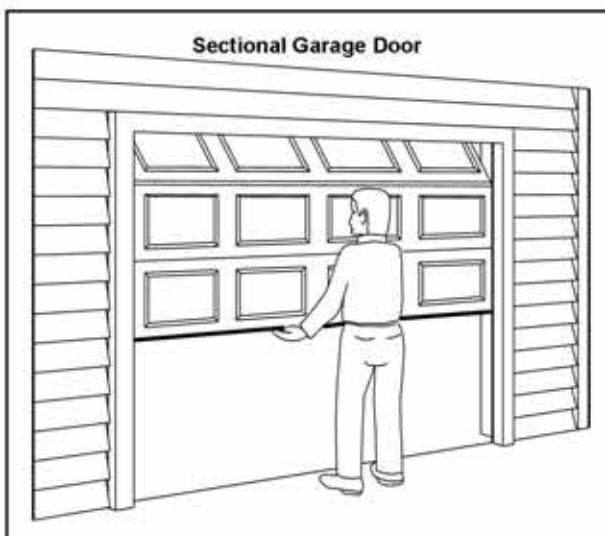

BEFORE Beginning Installation:

1. **Disable locks and remove all ropes connected to the garage door.**
2. **Perform the following door test to ensure your door is balanced and in good working condition.**

To Test Your Garage Door

1. Raise and lower the door to check if there is any sticking or binding.
2. Check for loose hinges, damaged rollers, frayed cables and damaged or broken springs.
3. Lift the door approximately halfway and release. The door should stay at the point under proper spring tension.

Call a qualified garage door service technician if your door binds, sticks or is unbalanced.

Tools Required

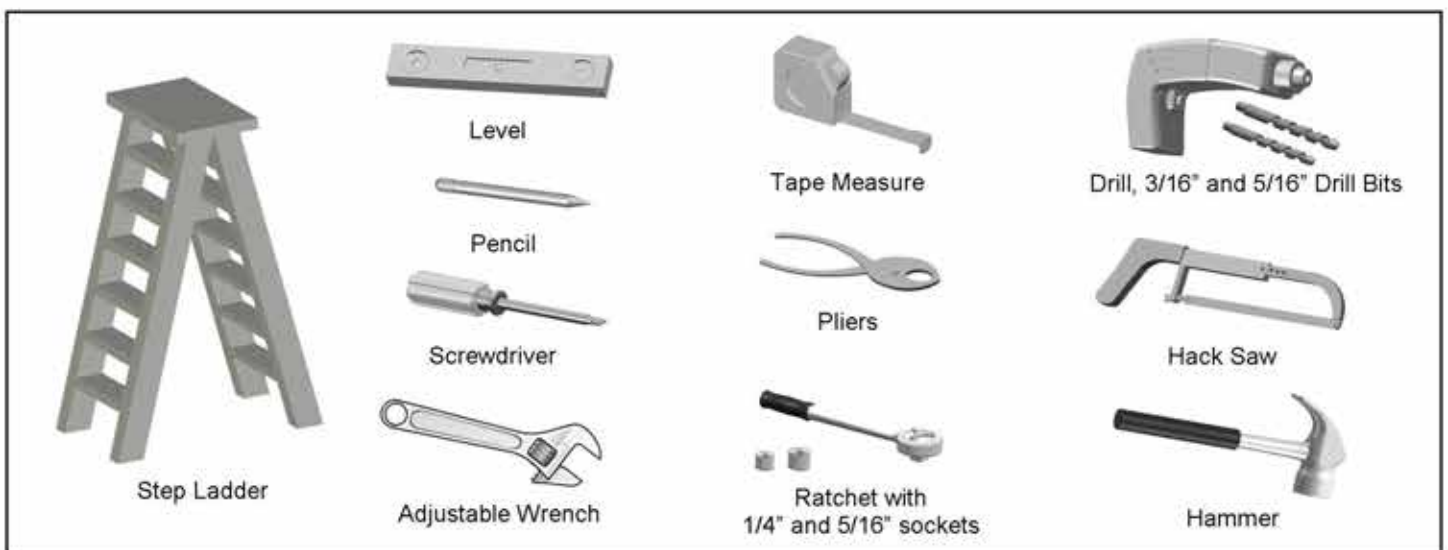

T-rail Assembly and Tensioning

⚠ CAUTION

- DO NOT connect power until instructed.
- To prevent INJURY, keep hands and fingers away from joints and possible sharp edges.
- Wear gloves when installing chain and cable.

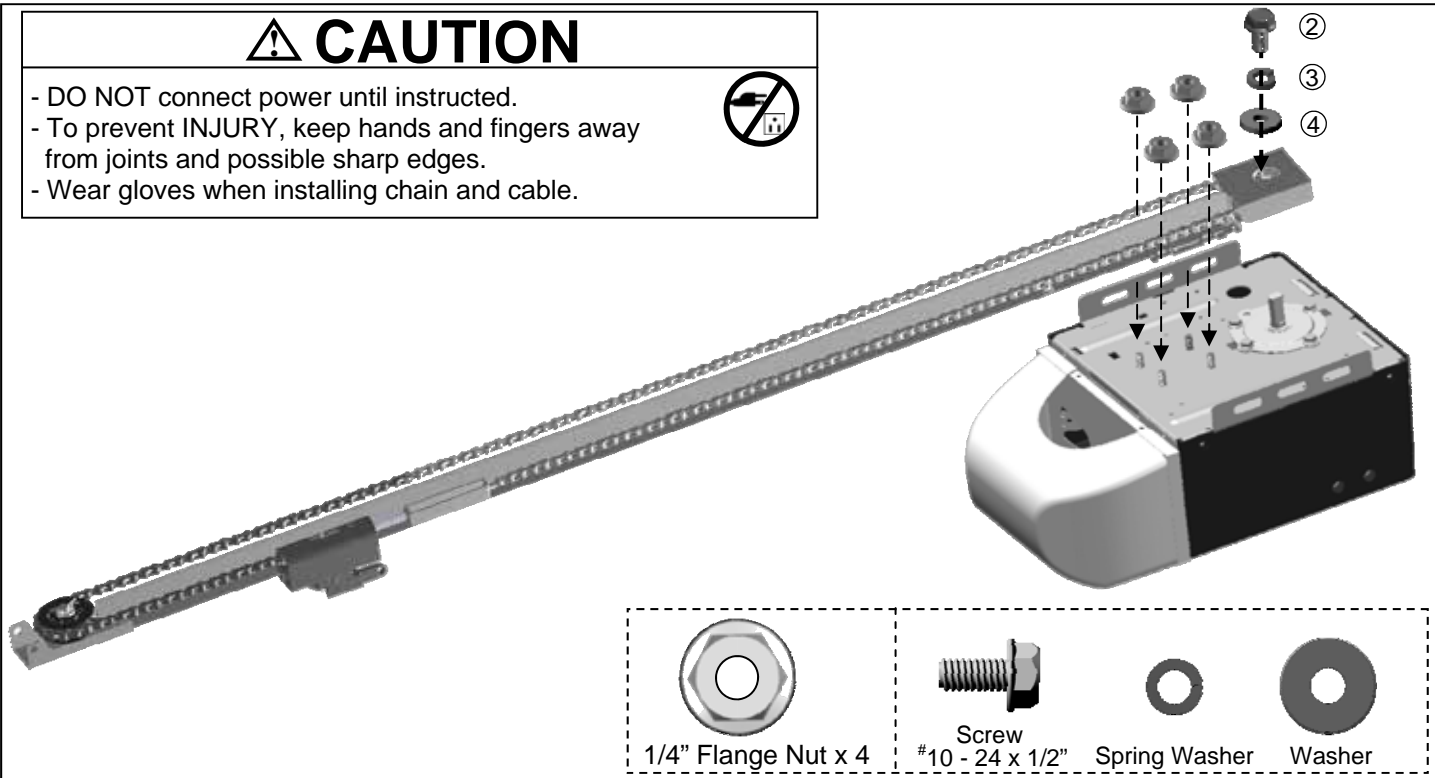

Fig.1

To Assemble the Rail

Align the pre-assembled T-rail on the top of opener in the direction as shown in Fig.1.

Secure the T-rail to the opener firmly using 1/4" flange nut x 4.

Final Step to T-Rail Installation

Fasten the Screw(2) to the motor shaft with spring washer(3) and washer(4) in between.

Note: The chain or belt rail assembly comes pre-tensioned from the factory. If installing with the optional belt rail, follow the same adjustment steps.

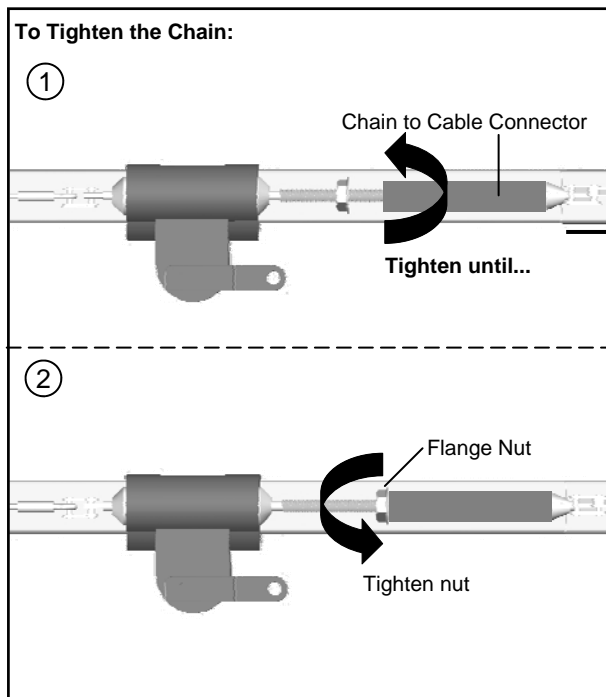
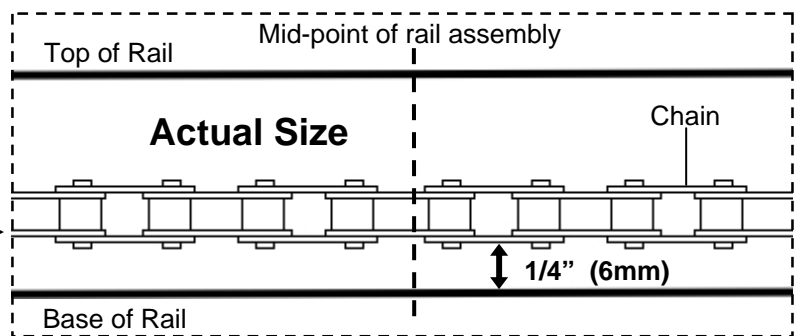

Fig.2



Follow steps shown in Fig.2 to tighten the chain:

1. Turn the Chain-to-Cable Connector on the Trolley Shaft until the chain is about 1/4" (6mm) above the base of the rail. Compare with the illustration below.
2. Tighten the Flange Nut on Trolley Shaft against the Chain-to-Cable Connector.

Notice

During operation, it is normal for the chain to appear loose when the door is closed. If the chain returns to the position as shown below when the door is opened, the chain is adjusted properly. DO NOT re-tighten the chain.

When performing maintenance, always PULL the Emergency Release to DISCONNECT the door from Opener before adjusting the chain.

Mounting Header Bracket

⚠ WARNING

To prevent **SERIOUS INJURY**:

- DO NOT connect power until instructed.
- The Header Bracket **MUST** be **SECURELY** fastened to the structural support on the mounting wall or ceiling, otherwise the door may not reverse when required. DO NOT install the Header Bracket over drywall.
- Concrete anchors **MUST** be used when mounting the Header Bracket into masonry.
- **NEVER** try to loosen, move or adjust garage door springs, cables, Pulleys, Brackets, or hardware, all of which are under **EXTREME** tension.
- Contact a qualified garage door service technician if your door binds, sticks or is unbalanced. An unbalanced door might not reverse when required.

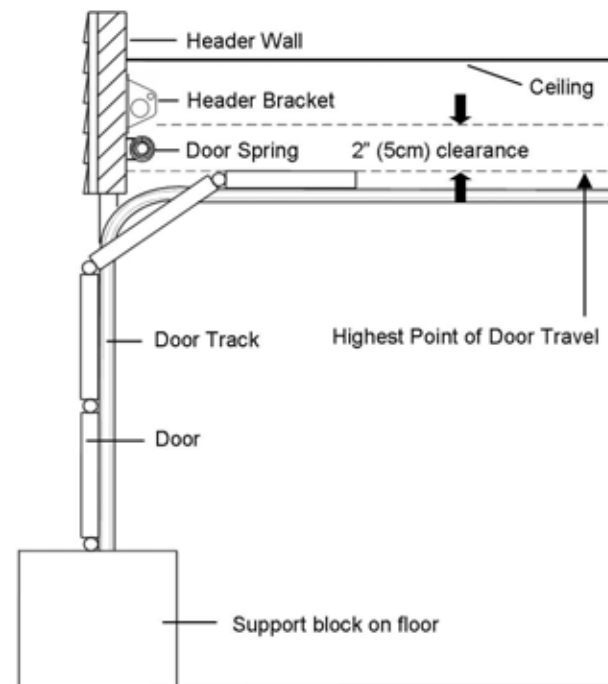

Fig.1

To Install Header Bracket

Note: Installation procedures may vary according to door type.

1. While inside your garage, close the door and mark the vertical centerline of the garage door. Extend the line onto the header wall above the door spring.
2. Open the door to the highest point of travel. Mark a line on the header wall 2" (5cm) above the highest point of travel.

Note: DO NOT install the Header Bracket over drywall. In some installations, it may be necessary to install a 2x4 across two wall studs to create a suitable location for the Header Bracket.

If installing into masonry, use concrete anchors (not provided).

Wall-Mounting

As shown in Fig.2, place the Header Bracket on the vertical centerline in direction shown.

Mark and drill two 3/16" holes. Fasten the Header Bracket securely to a structural support using two 5/16" x 2-1/2" Lag Screws.

Alternative Ceiling-Mounting

Ceiling-mounting is suggested **ONLY** when clearance is minimal.

Extend the vertical centerline onto the ceiling as shown in Fig.3. Center the Header Bracket on the vertical mark, no more than 6" (15cm) from the header wall. Mark and drill holes to fasten the Header Bracket securely to a structural support.

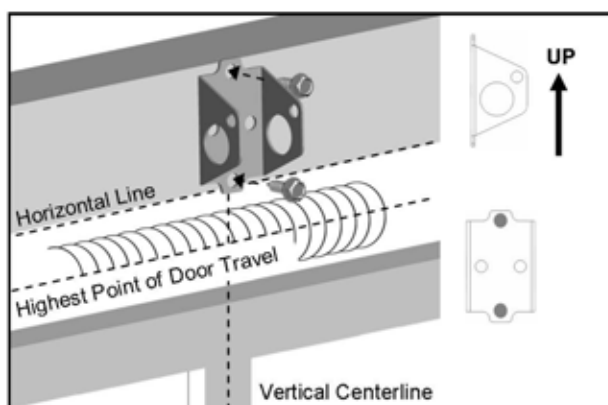

Fig.2 (Wall-Mounting)

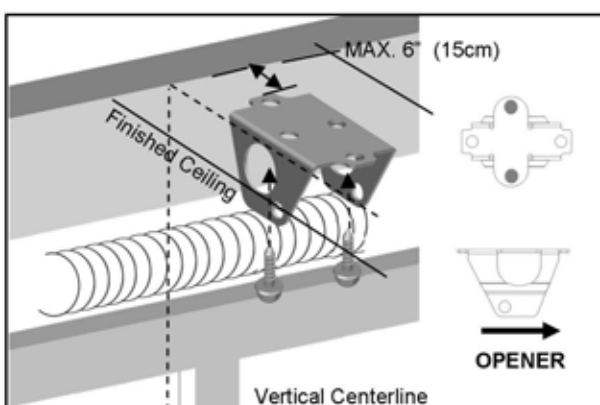
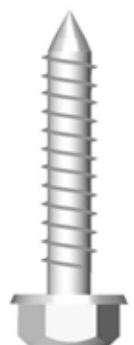

Fig.3 (Ceiling-Mounting)



Lag Screw
5/16" x 2-1/2"

Attaching Rail to Header Bracket and Mounting Door Bracket

WARNING

To prevent **SERIOUS INJURY**:

- DO NOT connect power until instructed.
- **REINFORCEMENT** is recommended for fiberglass, aluminum or lightweight steel garage doors **BEFORE** installing the door Bracket. Contact your door manufacturer for reinforcement options.

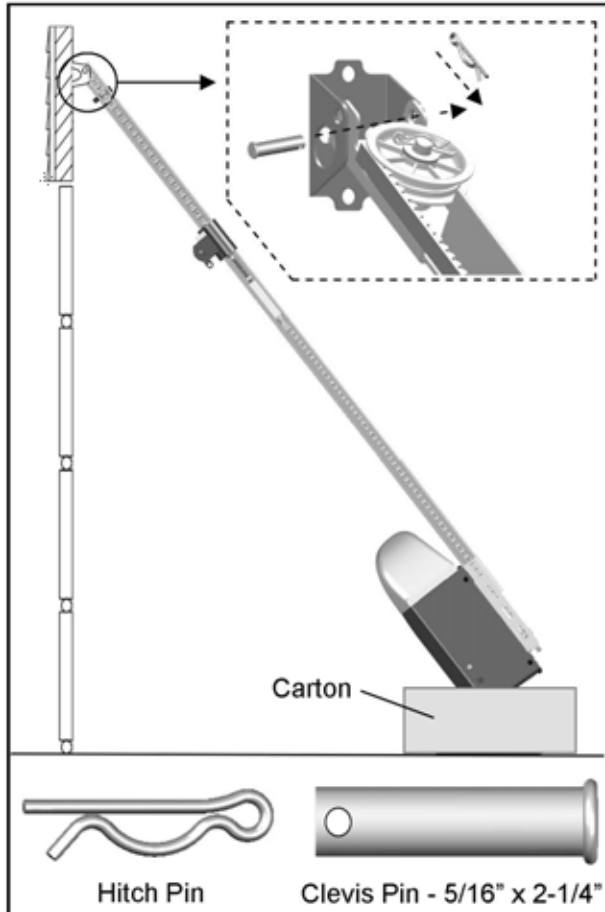

Fig.1

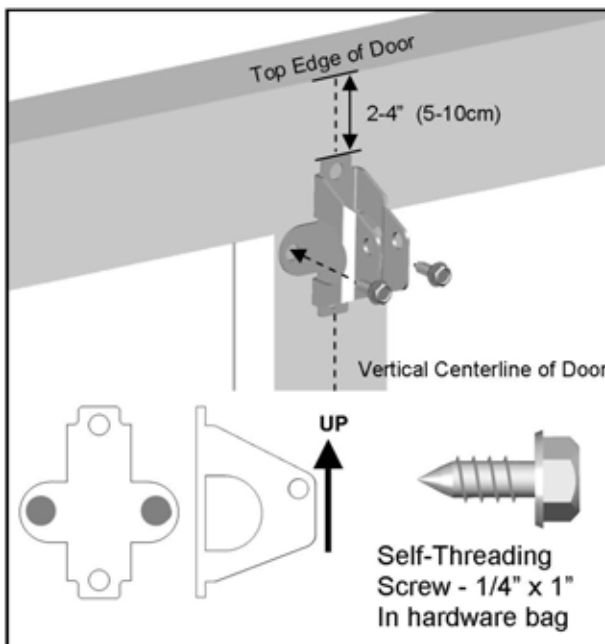

Fig.2

To Attach the Opener to the Header Bracket

1. As shown in Fig.1, use the packaging carton as temporary support for the Opener. Place the Opener on carton to prevent damage.
2. Align the mounting hole on the header rail to the mounting hole on the Header Bracket.
3. Connect the Header Rail and the Door Bracket together with a 5/16" x 2-1/4" Clevis Pin and lock it in place with a Hitch Pin.

To mount the Door Bracket

Note: Some door reinforcement kits may provide direct attachment of the door arm to the reinforcement bracket. If you have a door reinforcement bracket with this option, skip this step and proceed with the next step "Mounting Opener to Ceiling".

1. Position the Door Bracket on the centerline of the door approximately 2" - 4" (5-10cm) below the top edge of the door, as shown in Fig.2.
2. Depending on the construction of your door, install using one of the steps shown in Fig. 3 below:

For steel / lightweight doors with vertical steel reinforcements / factory reinforced.

(a) Mark and drill two 3/16" holes. Make sure not to drill through the garage door. Secure the Door Bracket with two 1/4" x 1" Self-Threading Screws (provided) as shown in Fig.3(a).

(b) Alternative installation: Drill two 5/16" holes through the door. Secure the Door Bracket using two 5/16" Bolts, lock washers and nuts (not provided) as shown in Fig.3(b). The length of bolts will depend on the thickness of your door.

Wood door

(c) Mark and drill two 5/16" holes through the garage door. Secure the Door Bracket using two 5/16" carriage bolts, washers and nuts (not provided) as shown in Fig.3(c). The length of bolts will depend on the thickness of your door.

Note: DO NOT use Self-Threading Screws on a wood door.

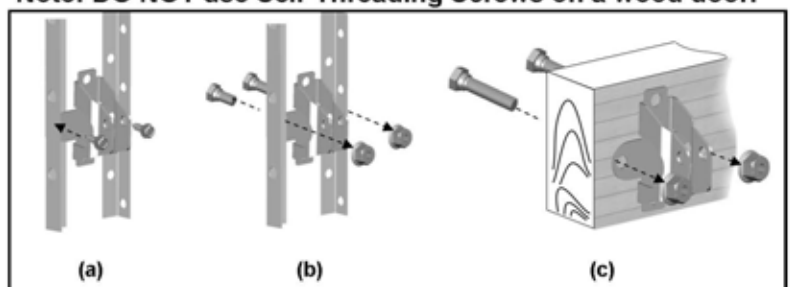

Fig.3

Mounting Opener to Ceiling

WARNING

To prevent SERIOUS INJURY or DEATH:

- DO NOT connect power until instructed.
- Install the Opener at least 7 feet (2.13m) above the floor.
- Fasten the Opener SECURELY to STRUCTURAL SUPPORTS of the garage to prevent falling.
- If installing Brackets to masonry, concrete anchors (not provided) MUST be used.

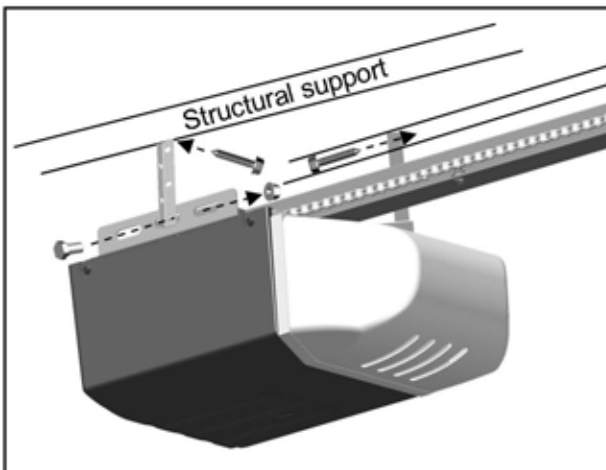

Fig.1

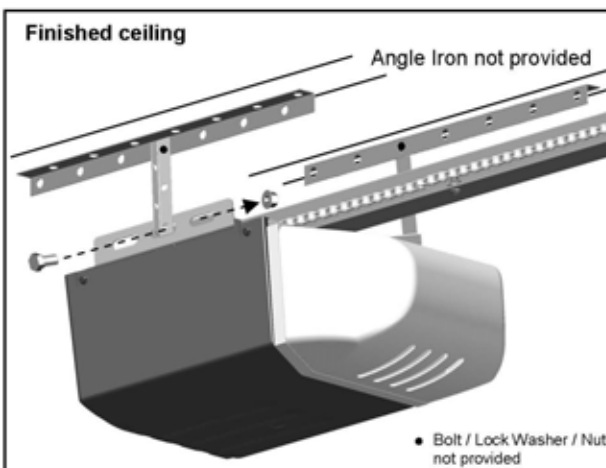

Fig.2

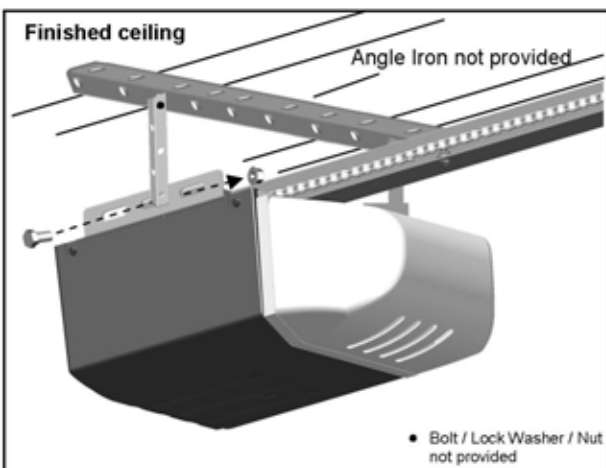

Fig.3

To Mount the Opener to Ceiling

The three most common installation options are shown in Fig.1-3.

Fig.1 shows mounting the Opener directly to structural support on the ceiling. Fig.2 and 3 show mounting on a finished ceiling, with heavy duty angle iron*. *(angle iron not included)

Determine the mounting option that works best for your application and follow installation steps below:

1. Raise the Opener and rail assembly and temporarily place it on a stepladder.
2. Position the Opener and rail assembly so that it is aligned to the center line of the garage door. If the Header Bracket was mounted off center, align the Opener with the Header Bracket.
3. Measure the distance from each side of the Opener to the structural supports.
4. Cut both Hanging Brackets* to appropriate length
*(Hanging Bracket not included)
5. Drill 3/16" holes in the structural supports.
6. Secure one end of each of the Hanging Brackets to the structural supports using 5/16"-18x1" Lag Screws (provided).
7. Secure the Opener to the Hanging Brackets and secure each side with a 5/16"-18x1"Bolt and Flange Nut (provided).
8. Move the door manually to check clearance between highest point of travel of the door and rail. If the door hits the rail, raise the Header Bracket or adjust the mounting of Opener.
9. Remove the ladder ONLY when the Opener is securely mounted to the structural supports.

Fastening Hanging Brackets to structural supports



Lag Screw 5/16" x 1-5/8"

Securing Opener to Hanging Brackets

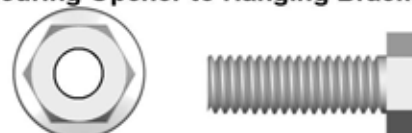

5/16" Flange Nut

Bolt 5/16" - 18 x 1"

Attaching Door Arms

⚠ WARNING

To prevent **SERIOUS INJURY**:

- DO NOT connect power until instructed.
- Keep hands and fingers away from the sprocket during operation.
- Wear gloves when installing chain and cable.
- Keep hands and fingers away from joints and possible sharp edges.



NOTE: The straight door arm must be installed vertically to the door when door is at closed position.

To Connect Door Arm

Follow the steps shown in Fig. 1

1. Fasten the Straight Door Arm to the Trolley with a 5/16" - 18 x 1" Clevis Pin and lock it with a Hitch Pin.
2. Fasten the Curved Door Arm to the Door Bracket with 5/16" - 18 x 1" Clevis Pin and lock it with a Hitch Pin.
3. To connect the door arms together, choose two pairs of holes which are as far apart as possible. Fasten the arms using two 5/16" - 18 x 1" Bolts and Flange Nuts.

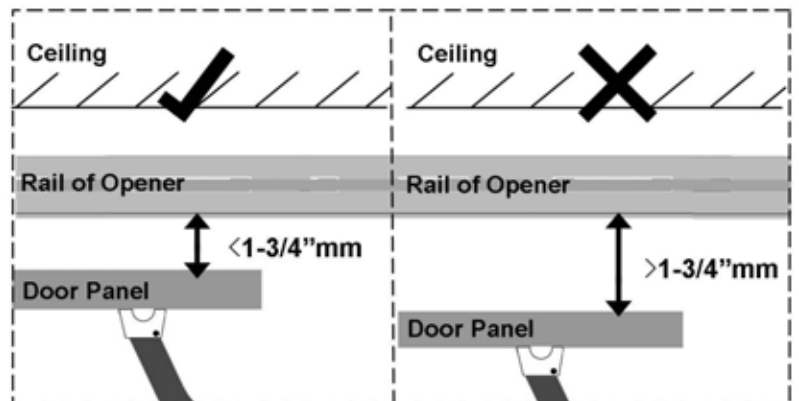
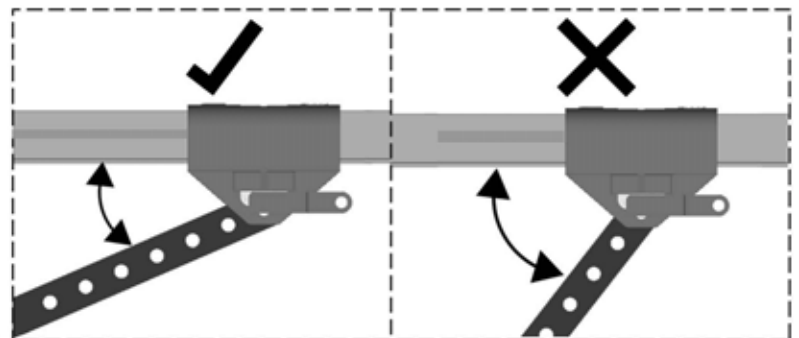
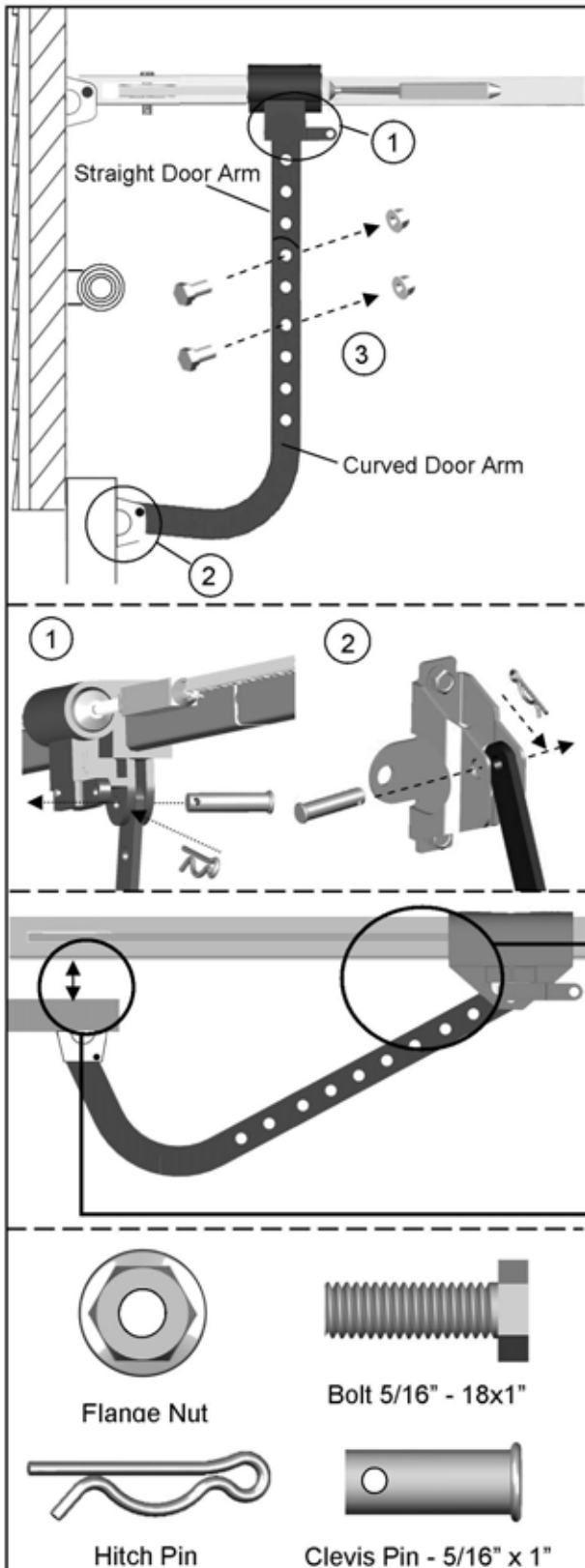

Fig.1

Installing Light and Emergency Release Handle

WARNING

To prevent **SERIOUS INJURY** or **DEATH** from electrocution:

- Disconnect power cord before installing/replacing light bulb.

To prevent possible **OVERHEATING** or damage to Opener:

- Use **ONLY** A19 (E26) incandescent bulbs (100W max.).

- **DO NOT** use short neck or specialty light bulbs.

- **DO NOT** use halogen bulbs.

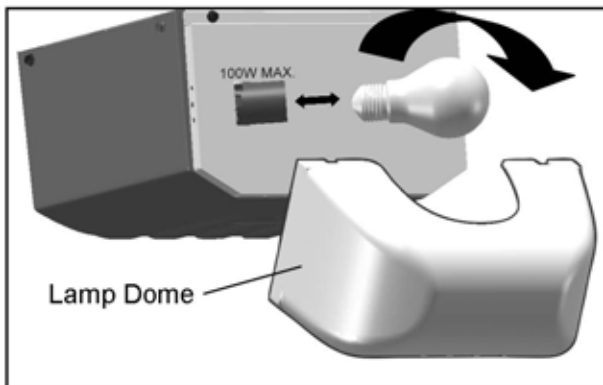

Fig. 1

To install the light:

1. Pull the Lamp Dome from the top and detach it from the Opener.
2. Install a standard A19 (E26) 100 watt maximum light bulb.
3. Re-attach the Lamp Dome.

Notice

When replacing the light bulb, make sure the bulb on the Opener has cooled down to prevent injury.

WARNING

To prevent **SERIOUS INJURY** or **DEATH** from a falling garage door:

- In case of power failure or door obstruction, **PULL EMERGENCY HANDLE** to release door from Opener.

- When Emergency Release is in the released position, the door can be operated manually.

- To reconnect, flip the lever on the Trolley towards Opener, back to Connect position, it will reconnect automatically upon pressing Push Button or remote control.

- **DO NOT** use Emergency handle to pull the door open or closed.

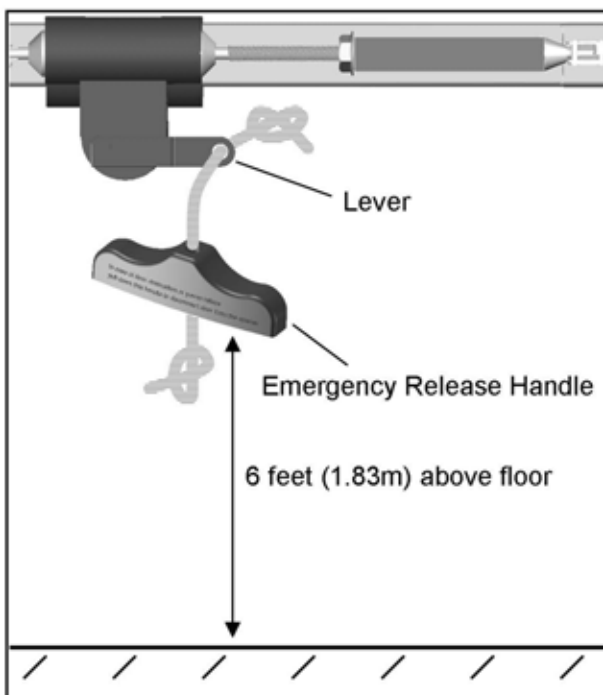

Fig. 2

Safety Notice

Mount the emergency release within reach, but at least 6 feet above the floor and avoiding contact with vehicles to avoid accidental release

To attach the Emergency Release Handle:

1. Thread one end of the rope through the hole of the Emergency Release Handle and secure with an overhand knot.
2. Thread the other end of the rope through the hole in the Trolley lever.
3. Measure the rope length so that the Handle is 6 feet (183cm) above the floor and is clear from the top of your vehicle. Secure with a overhand knot.

Wiring Instructions

WARNING

To prevent **SERIOUS INJURY** or **DEATH** from electrocution:

- Power **MUST NOT** be connected until instructed.
- **NO** exposed part of the wire should be visible outside of the terminal for proper connection.

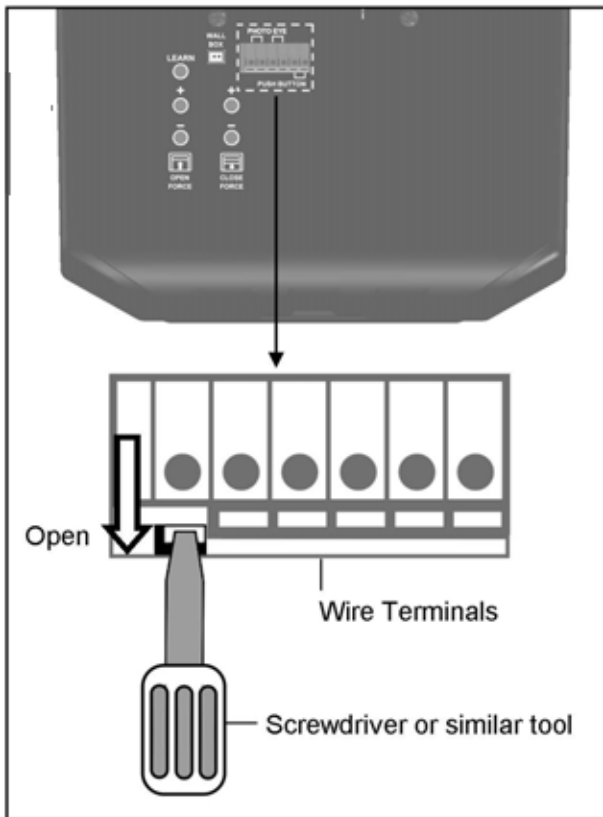

Fig. 1

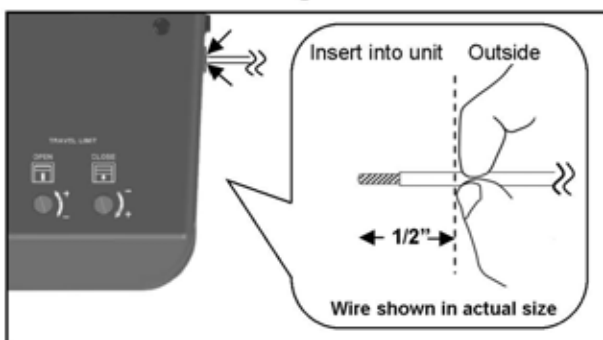

Fig. 2

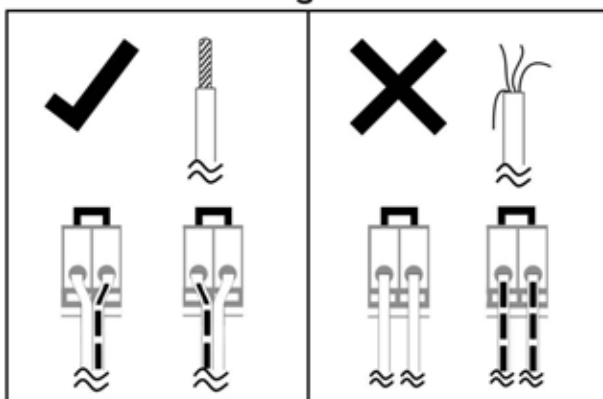
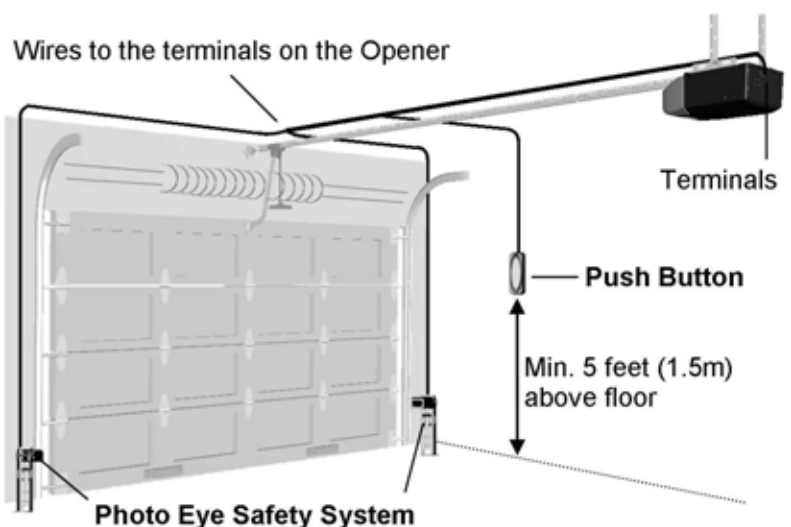

Fig. 3

In the following section, the **Photo Eye Safety System** and **Push Button** will be connected to the Opener. Please read and understand the wiring instructions before connecting wires.

1. The connection terminals on the rear panel of the Opener are used to connect wires from accessories.
2. To connect a wire to an assigned terminal, use a small "flat head" screwdriver to push in the orange tab on the Wire Terminal as shown in Fig.1.
3. Insert approximately 1/2" (13mm) of the wire into the terminal while pushing in the tab as shown in Fig.2.
4. Wires **MUST NOT** be frayed and connected properly as shown in Fig.3. Each accessory requires a pair of terminals, Each pair of terminals **MUST** be connected with one white wire and one striped wire (non-polarized) from the **SAME** accessory.
5. Check for proper connection by gently pulling on the wire. The wire should not come out of the terminal. **NO** exposed part of the wire should be visible outside of the terminal.
6. Use the insulated staples provided to secure the wires to the wall and/or ceiling. Be careful not to damage the wires while securing the staples.



Connecting Photo Eye Safety System

WARNING

To prevent **SERIOUS INJURY** or **DEATH** from electrocution:

- Power **MUST NOT** be connected **BEFORE** Photo Eye Safety system is connected and aligned.
- The Opener will not operate until the Photo Eye Safety System is properly connected and aligned.
- Install the Photo Eyes **NO** higher than 6" (15cm) above the floor.



No part of garage door or other objects should obstruct the Photo Eye Safety System during door-closing.

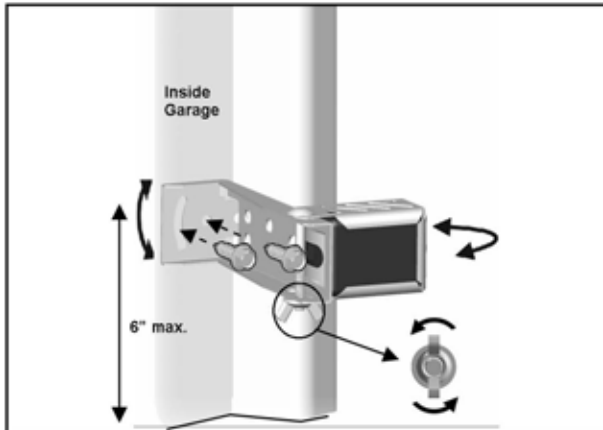

Fig. 1 (Wall Mount)

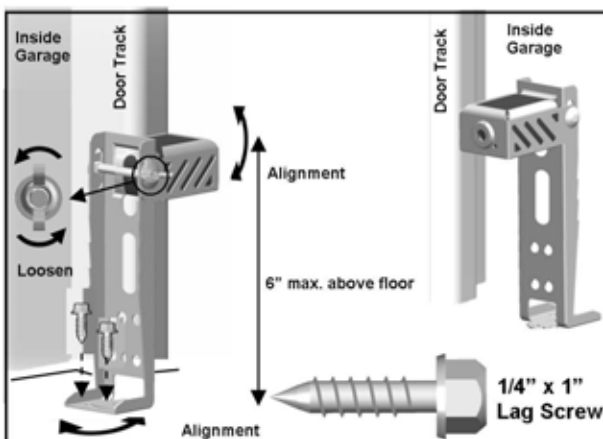

Fig. 2 (Floor Mount)

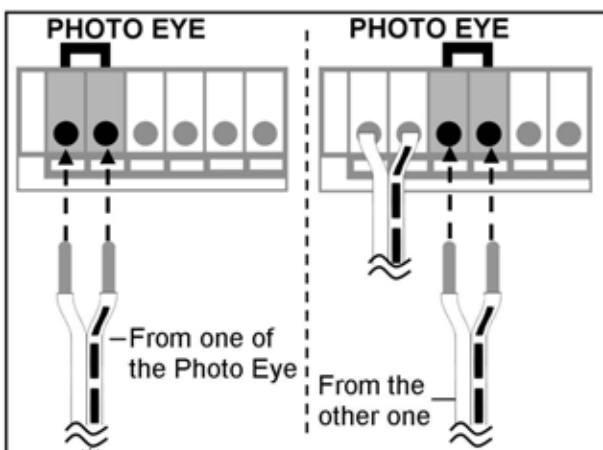

Fig. 3

About the Photo Eye Safety System

The Photo Eye Safety System provides protection against entrapment while the door is closing. When properly connected and aligned, the emitter Photo Eye emits an invisible infrared light beam while the Sensor Photo Eye monitors that beam.

If the beam is obstructed during door-closing, the entrapment protection will be triggered and the door will stop and reverse to the open position. The courtesy light will flash for 30 seconds indicating an obstruction.

Installing The Photo Eye Safety System

Wall-mounting

1. Place the Photo Eyes facing each other on each side of the garage door. Position the sensors so they are no higher than 6" (15cm) above the floor, as shown in Fig.1.
2. Drill 3/16" holes using the mounting holes on the Bracket as a template. Secure with 1/4" x 1" Lag Screws (provided).
3. If necessary use the Optional Wall-mount Position (Fig.1) to better fit your door-track and improve obstacle avoidance. To adjust the position, loosen the wing nut, disassemble the Bracket and move the Photo Eye to the lower position on the holder.
4. If necessary, align the Photo Eyes by loosening the wing nut. (This step may be further required in **Aligning the Photo Eye Safety System** on page 15.)

Alternative Floor-mounting

1. Place the Photo Eyes facing each other on each side of the garage door, as shown in Fig.2.
2. If attaching to concrete, secure the photo eyes using concrete anchors and bolts (not provided).
3. If necessary, align the Photo Eyes by loosening the wing nut. (This step may be further required in **Aligning the Photo Eye Safety System** on page 15.)

To Connect Photo Eye Safety System

1. Connect a pair of wires from either one of the Photo Eyes to a pair of "PHOTO EYE" terminals on the rear of the Opener as shown in Fig. 3. Refer to **Wiring Instructions** on page 12 for proper connections.
2. Repeat above step to connect the other Photo Eye.
3. Refer to **Wiring Instructions** on page 12 to ensure wires are connected properly.

Connecting Push Button

WARNING

To prevent **SERIOUS INJURY** or **DEATH** from electrocution:

- Power **MUST NOT** be connected until instructed.

To prevent **SERIOUS INJURY** or **DEATH** from using the Push Button and a closing door:

- Install the Push Button within sight of the door at a minimum height of 5 feet (1.5m) above the floor. Make sure it is out of the reach of children and moving parts of door and hardware.
- **NEVER** permit children to access the Push Button or Remote Controls.
- Operate the door **ONLY** when it is adjusted properly with no obstructions present and is in clear sight.
- **ALWAYS** keep a moving door in sight until it's completely closed.
- **NEVER** cross the path of a moving door.

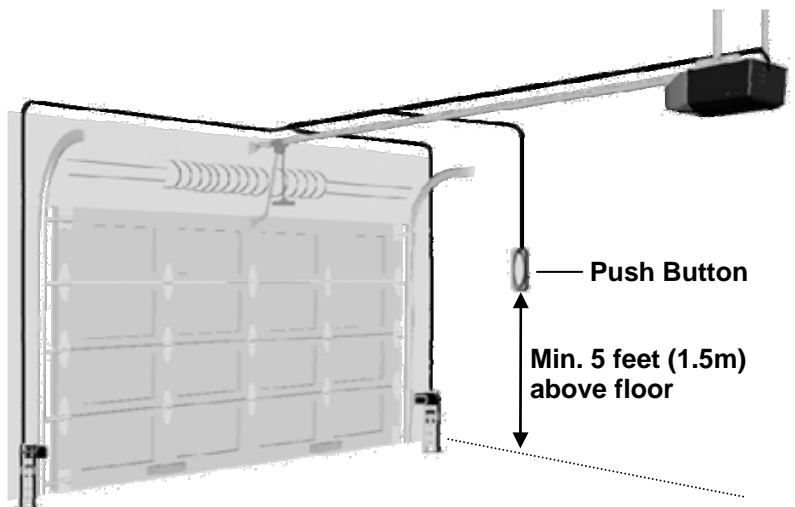
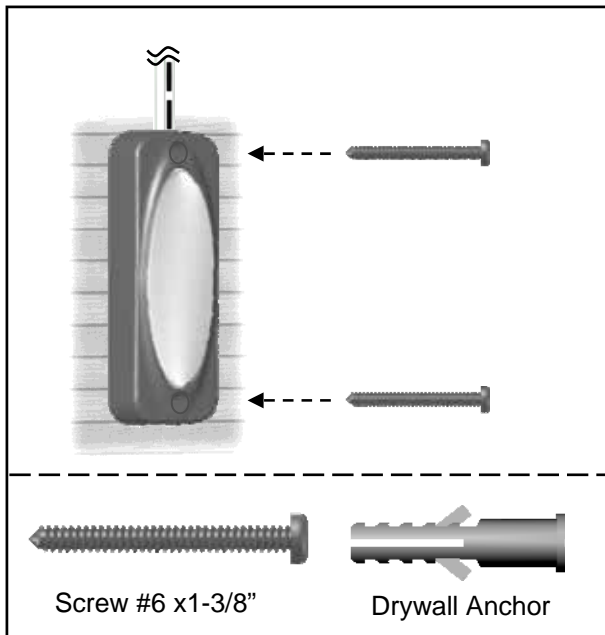

The Push Button is a wired, illuminated door control placed inside your garage.

To install the Push Button:

1. Inside your garage, install Push Button within sight of the door at a minimum height of 5 feet (1.5m) off the ground. Ensure it is installed out of the reach of children and free from the moving parts of the door and hardware.
2. Securely fasten it to a solid surface with # 6x1-3/8" screws provided. If attaching to drywall or other hollow surface, drill 3/16" holes and use the provided Drywall Anchors.

To Connect the Push Button to the Opener

Connect the pair of wires from the Push Button to the pair of "PUSH BUTTON" terminals on the rear of the Opener. Refer to **Wiring Instructions** on page 12 to ensure wires are properly connected.

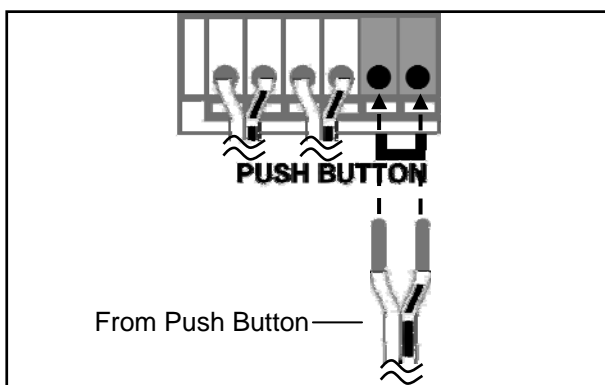

Connecting Power

WARNING

To prevent **SERIOUS INJURY** or **DEATH** from electrocution or fire:

- Power **MUST** be **DISCONNECTED** BEFORE proceeding with permanent wiring procedures.
- Garage Door Opener installation and wiring **MUST** be in compliance with all local electrical and building codes. Make sure the Opener is **ALWAYS** grounded.
- **NEVER** use an extension cord, 2-wire adapter or modify the power plug in any way to make it fit the outlet.



Ordinary Power Connection

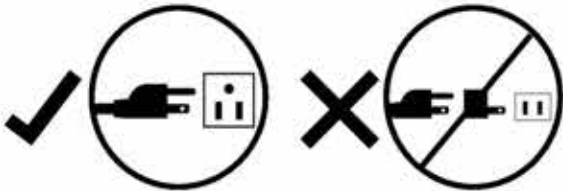

DO NOT OPERATE OPENER AT THIS TIME.

To Connect Power

Plug the Opener into a grounded outlet **ONLY**. If there is no grounded outlet present, call a qualified electrician to replace the outlet. Use of a surge protector is highly recommended page 4.

Permanent Wiring (If Required by Local Code)

1. Remove the enclosure by removing the 6 screws located on the sides and rear of the Opener.
2. Cut the two cable pressure connectors connecting line (black) and neutral (white) wire from the power cord.
3. Remove the grounding screw connecting the green wire.
4. Remove the power cord.
5. Group neutral (white) wires from power source with 2 white wires from light cable, and logic board, and yellow wire from motor, inside the Opener. Connect them with a wire nut.
6. Group line (black) wires from power source with another black wires from logic board inside the Opener. Connect them with a wire nut.
7. Secure the ground (green or bare) wire from the power source with a grounding screw.
8. Reinstall the enclosure.
9. Turn on power supply. If the wiring is properly connected, a "click" should be heard and the light will illuminate (if a bulb is installed). If there is no response from the Opener, check power source and wiring.

For Permanent Wiring ONLY

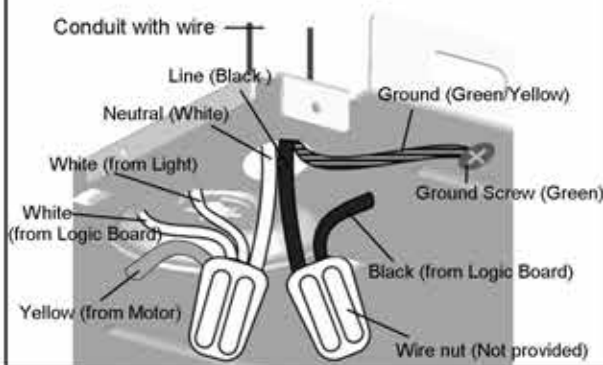

Aligning the Photo Eye Safety System

WARNING

To prevent **SERIOUS INJURY** or **DEATH** from a closing garage door:

- The Photo Eye Safety System **MUST** be installed **BEFORE** connecting power.
- The Photo Eye Safety System **MUST** be properly connected and aligned **BEFORE** operating the Opener.

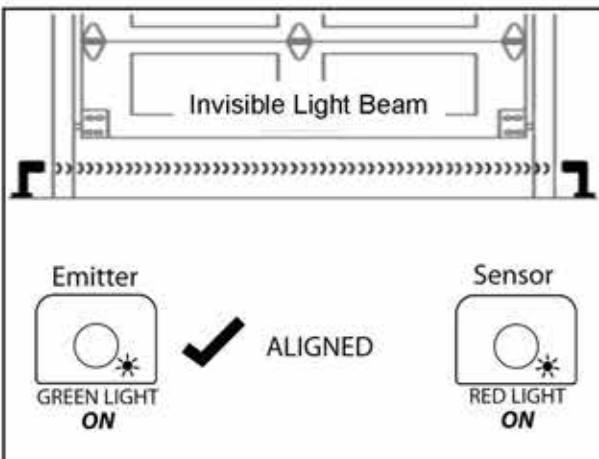

To Align the Photo Eye Safety System:

1. When the Photo Eye System is properly connected and the power is connected, one of the Photo Eyes will emit a steady green light. This Photo Eye is the Emitter that generates the Invisible Light Beam.
2. When properly aligned, the Sensor should emit a steady red light when it senses the invisible light beam from the Emitter.
3. If the indication is unsteady, flashes or is dim, check for any obstructions and adjust the position until the Sensor gives a **STEADY RED LIGHT**.

Note: The path of the invisible light beam **MUST NOT** be obstructed. No part of the garage door or any hardware should interfere with the beam or the Opener will not close the door.

Travel Limit Adjustment

WARNING

To prevent **SERIOUS INJURY** or **DEATH** from improper Force Adjustment:

- Improper adjustment of travel limits will cause operation of safety reversal mechanism.
- If Travel limit adjustment is made, Force Adjustment may also be needed.
- After **ANY** adjustments, the Safety Reverse Test **MUST** be performed to ensure the door reverses on contact with a 1-1/2" thick object (2x4 laid flat).

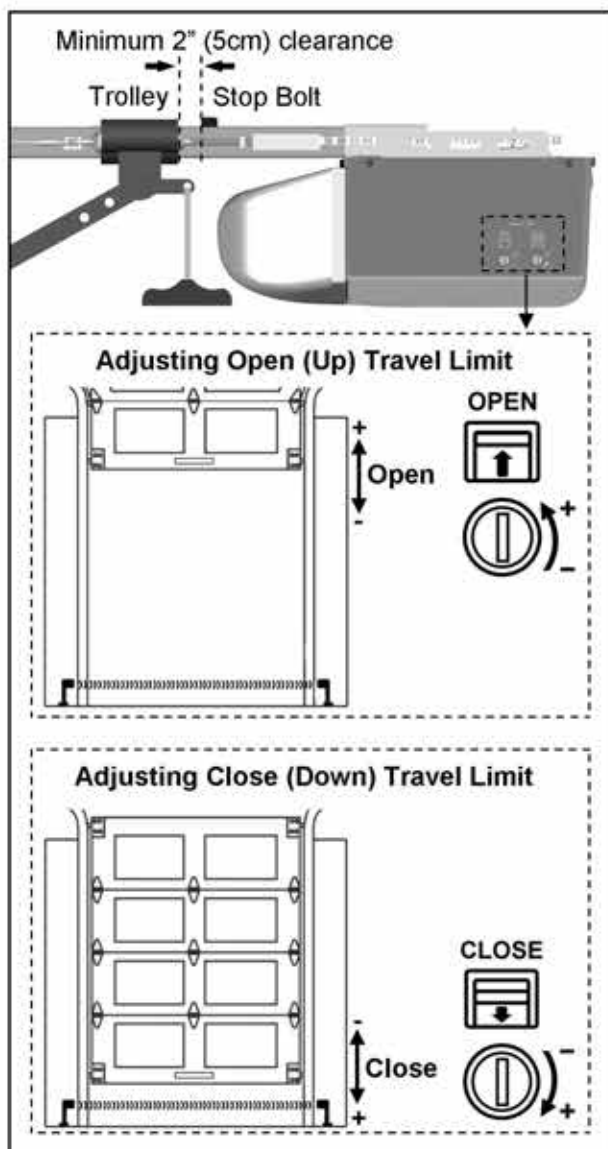
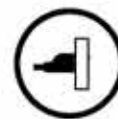

If the door reverses unintentionally during closing, check below symptoms:

1. The Photo Eye System may be improperly connected, misaligned or obstructed. The courtesy light will flash continuously for 30 seconds. Refer to **Troubleshooting** on P.22.
2. Binding door — Disconnect the door from the Opener by using the Emergency Release Handle. Open and close the door manually and check the following steps.
 - 2.1 If the door is balanced, refer to "Force Adjustment" to adjust Close force.
 - 2.2 If the door is unbalanced, binding or jammed, call a trained service person to adjust the door.

About Travel Limits

Limit Adjustments regulate the position at which the door will stop when opening and closing.

BEFORE making any adjustments, operate the door by using the Push Button or Remote Control. Run the Opener through a complete cycle.

If the door opens and closes completely without unintended reversing upon closing — NO adjustment is necessary.

If the door does not open or close at desired positions, proceed with the instructions below to adjust the travel limits.

Adjusting Travel Limits

Open and Close Limits can be increased (+) or decreased (-) by turning the corresponding screws on the Opener. Use a "flat head" screwdriver to make adjustments. One full turn of the screw is about 2" (5cm) of actual travel.

NOTE: The Opener motor includes an automatic thermal protection system which will shut down the motor in an overheat situation. The thermal protector will reset itself once the motor cools down. Opening and closing the Opener multiple times (in a short period of time) may cause the motor to overheat and shut down. If this happens, wait about 15 minutes for the motor to cool and retry operation.

Setting OPEN (UP) Travel Limit

1. **CLOSE** the garage door by using either the Remote Control or Push Button.
2. Adjust the OPEN Limit Screw.
3. **OPEN** garage door and check for proper adjustment.
4. Repeat steps 1-3 until the door opens to the desired position. When the door is in the open position, make sure there is enough clearance for your vehicle(s), and there is a minimum 2" (5cm) gap between Trolley and Stop Bolt.
5. Perform **Safety Reverse Test** on page 18.

If the door does not open past 5 feet (1.5m), follow **Force Adjustment** on page 17 to adjust the Open Force.

Setting CLOSE (DOWN) Travel Limit

1. **OPEN** the garage door by using either the Remote Control or Push Button.
2. Adjust the CLOSE Limit Screw.
3. **CLOSE** the garage door and check for proper adjustment.
4. Repeat steps 1-3 until door closes to the desired position.
5. Perform **Safety Reverse Test** on page 18.

Force Adjustment

WARNING

To prevent **SERIOUS INJURY** or **DEATH** from improper Force Adjustment:

- **DO NOT** adjust force to compensate for binding or sticking of the garage door. Call a qualified garage door service technician to make necessary adjustments in case of binding.
- **DO NOT** increase the force beyond minimum force required for closing the door. Too much force will cause improper operation of safety reversal mechanism.
- If either the Force or Travel limit adjustment is made, the other adjustment may also be needed.
- After **ANY** adjustments, the Safety Reverse Test **MUST** be performed to ensure the door reverses on contact with a 1-1/2" thick object (2x4 laid flat).

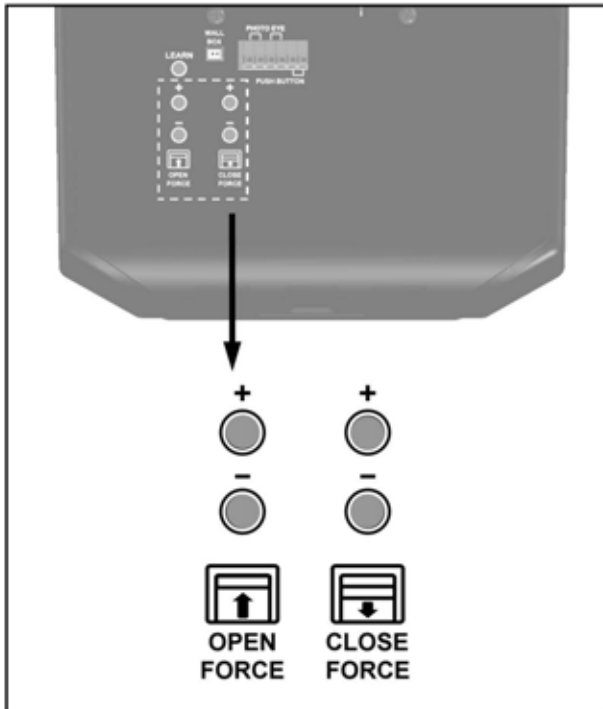

For safe operation, the force setting should always be set at the MINIMUM FORCE required to run the door.

Adjusting Force

1. Force Adjustment controls are located on the rear panel of the Opener. The force adjustments regulate the amount of force required to open or close the door.
 2. Force Adjustment is applied only to compensate for the minor resistance caused by weather or other means.
- Note: Force is preset at level 6 for both Open and Close adjustments. The size and operating conditions of the garage door will determine the correct level of Force/Sensitivity. Weather conditions may also affect the operation of the door requiring further adjustments as needed.
 - Note: If the close force is set too light the Opener will reverse the door during closing. If the open force is set too light the Opener will stop the door during opening.
 - Note: There are 12 levels for open and close force settings. When either the maximum or minimum level is reached, the light will flash 6 times.
 - Never adjust the force setting by more than 1 level (1 press) at a time.

Setting Force

Setting Close Force

1. If the door completes a full close cycle without reversing, decrease (-) the Close Force by 1 level at a time until the door reverses. If the door reverses during closing, increase (+) Close Force by 1 increment. The Close Force is now properly adjusted.
2. During the "door-close" cycle, the Opener will reverse if the force required to close the door is exceeded.

Setting Open Force

1. If the door completes a full open cycle without stopping, decrease (-) the amount of force by 1 level until the door stops during the opening. Once the door stops during opening, increase (+) Open Force by 1 increment. The Close Force is now properly adjusted.
2. During the "door-open" cycle the Opener will stop if the force required to open the door is exceeded.

Final Adjustments and Testing

WARNING

To prevent **SERIOUS INJURY** or **DEATH** from a closing garage door:

- The Safety Reversal Test **MUST** be conducted **ONCE A MONTH**.
- **NO ONE** should cross the path of moving door during operation and/or testing.
- If either Force or Travel limit adjustment is made, the other adjustment may also be needed.
- After **ANY** adjustments to the door system, the Safety Reverse Test **MUST** be performed to ensure the door reverses on contact with a 1-1/2" thick (2x4 laid flat) object.
- The Photo Eye Safety System **MUST** be properly aligned, and tested regularly.

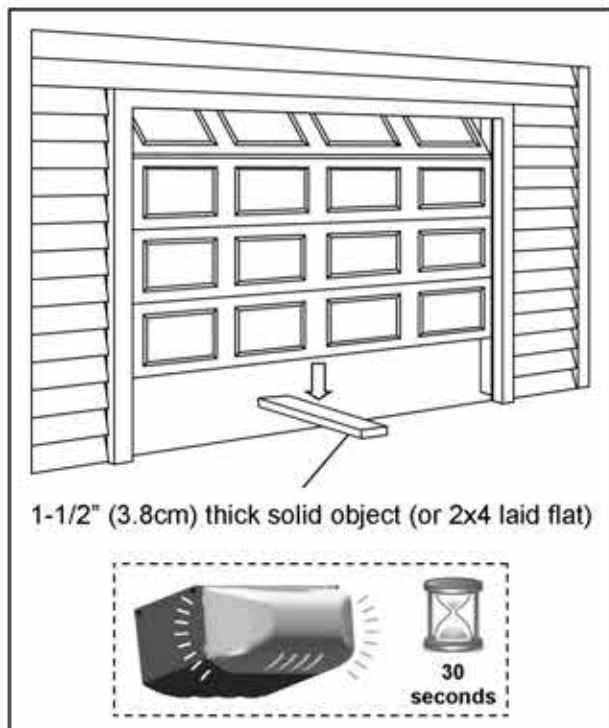

Testing the Safety Reverse System

The Safety Reverse System prevents the door from closing when an obstruction is present.

1. Open the door by using the Push Button or Remote Control.
2. Place a 1-1/2" (3.8cm) thick solid object (or 2x4 laid flat) on floor under the center of garage door.
3. Keeping the door in sight, use the Push Button or Remote Control to close the door.
4. The door **MUST REVERSE** upon striking the object within 1.5 seconds, and stop at the fully opened position.
5. The courtesy light will start flashing for 30 seconds upon triggering the Safety Reverse System.

If the door just stops on the object, adjust the Opener as follows:

The close travel maybe inadequate, increase Close travel limit by 1/4 turn (See **Limit Adjustment** on page 16)

Conduct the test again. If the door reverses on contact, remove the object and run at least 3 **COMPLETE** travel cycles to ensure proper adjustment.

If the door still does not reverse on the object, decrease the Close Force (see **Force Adjustment** on page 17) and repeat the test.

If the Opener still fails the Safety reverse Test, call a qualified technician for door adjustment.

Testing the Photo Eye Safety System

1. Open the door by using the Push Button or Remote Control.
2. Make sure both Photo Eyes steadily emit the green and red indicator lights. (If not, check alignment)
3. Place an object under the door about 8" (20cm) high by 12" (30cm) wide (the Opener carton can be used),
4. The green indicator on emitter eye will flash and the red indicator light on the sensor eye should be dimmed.
5. Keep the door in sight and use the Push Button or Remote Control to try to close the door.
6. The door should **NOT** move more than 1" (2.5cm) and the courtesy light should flash for 30 seconds.

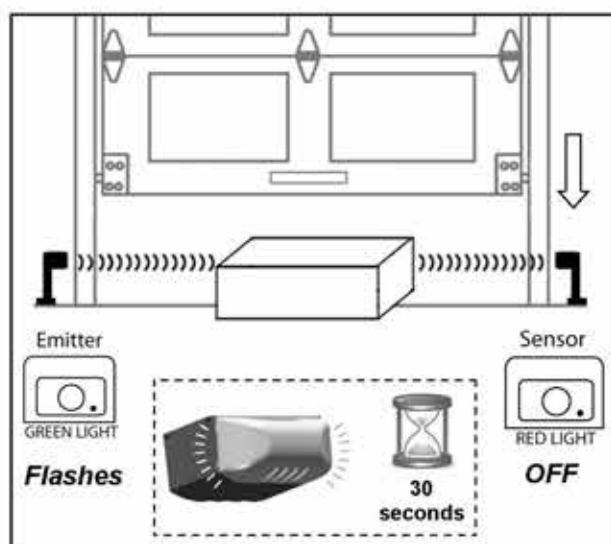

Programming Remote Controls* (OPTIONAL)

WARNING

To Prevent SERIOUS INJURY or DEATH:

- Keep Remote Control and battery out of reach of children.
- NEVER permit children to access the Push Button nor Remote Controls.
- Operate the door ONLY when it is properly adjusted, and there are no obstructions present.
- ALWAYS keep a moving door in sight until completely closed. NEVER cross the path of a moving door.



To reduce risk of fire, explosion or electric shock:

- DO NOT short circuit, recharge, disassemble or heat the battery.
- Replace with 23AE 12 Volt batteries ONLY. Dispose of batteries properly.



Fig.1

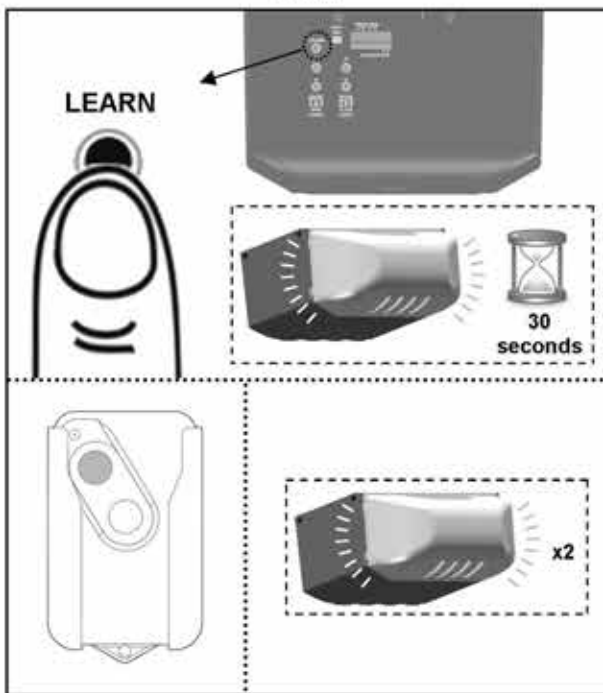

Fig.2



Fig.3

To Program Remote Control(s):

1. See Fig.2 to add a Remote Control. Press the "LEARN" button on the rear control panel of the Opener. The courtesy light will illuminate with an audible click*. The unit is now ready to learn a Remote Control.
2. Within 30 seconds, press the button on the Remote Control.
3. The courtesy light will flash twice indicating Remote Control has been stored successfully**.

Up to 20 Remote Controls (including wireless keypad codes) can be added to the unit by repeating the above procedures.

If more than 20 Remote Controls are stored, the first stored Remote Control will be replaced. (i.e. the 21st Remote Control replaces the 1st stored Remote Control.)

* If the courtesy light is already on, it will flash once and stay illuminated for 30 seconds.

** If a Remote Control is not accepted, the courtesy light will stay on for 30 seconds, flash 4 times and then stay on for 4-1/2 minutes. Retry programming the Remote Control by repeating the steps above.

Removing ALL Remote Controls:

To remove ALL Remote Controls from memory, press and hold the "LEARN" button for 5 seconds. The courtesy light will flash 7 times indicating ALL Remote Controls have been removed from memory.

Replacing Remote Control Battery:

When the battery of the hand held Remote Control is low, the indicator light will become dim and/or the range of the Remote Control will diminish. To replace the battery, remove the battery cover from the Remote Control as shown in Fig. 3. Replace with a 23AE 12 volt alkaline battery with polarity shown in Fig.3.

This device complies FCC Rules for HOME OR OFFICE USE. Operation is subject to the following two conditions: (1) this device may not cause harmful interference, and (2) this device must accept any interference received, including interference that may cause undesired operation.

Operating the Opener

⚠ WARNING

To Prevent SERIOUS INJURY or DEATH:

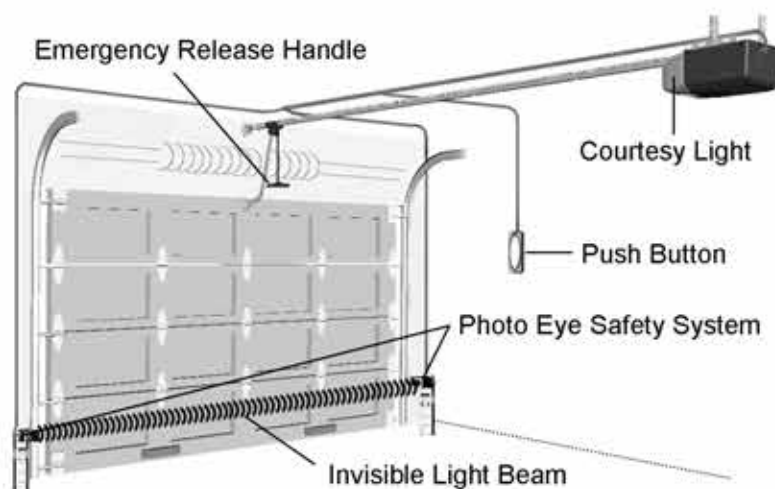

- READ AND FOLLOW ALL INSTRUCTIONS AND **WARNING**S IN THE OWNER'S MANUAL AND LABELS

- Keep Remote Control and battery out of reach of children.
- NEVER permit children to access the Push Button Remote Controls.
- Operate the door ONLY when it is properly adjusted, and there are no obstructions and is in clear sight.
- ALWAYS keep a moving door in sight until completely closed. NEVER cross the path of a moving door.
- If Travel limit adjustment is made, Force Adjustment may also be needed.
- After ANY adjustments, the Safety Reverse Test MUST be performed to ensure the door reverses on contact with a 1-1/2" thick object (2x4 laid flat).
- ALWAYS ensure that your door is balanced and in good working condition.



Actual Operating Scenario

Activating the Opener

Controls	Operation
 Push Button (Indoor)	Press and hold the Push Button until the door starts to move, and controls as follows: <ul style="list-style-type: none"> - Open or close the door. - Reverse the door while it is closing - Stops the door while it is opening. - Close the door when the Photo Eye Safety System is not installed, misaligned or obstructed INTENTIONALLY.
 Remote Control	Same functions* as the Push Button with remote distance up to 100ft. in open field. *For safety concerns, the Hand-Held Remote Control WON'T work if the Photo Eye Safety System is not properly installed and aligned.
Wireless Keyless Entry Keypad*	Program the Wireless Keyless Entry Keypad accordingly and access the door using the PIN code.

*Optional

Operating the Opener

Door Status vs. Activation

Door status	 Activation using Push Button / Remote Control
Door at fully open / close position	Door will move to fully close / open position
Door is closing	Door will reverse
Door is opening	Door will stop
Door is stopped as intended in partially open position	Close
Door is obstructed while closing	Door will reverse while flashing courtesy light
Door is obstructed while opening	Door will stop
Door is fully opened and Photo Eye System is obstructed	Door will not close

Courtesy Light Responses

Operation / Condition	 Courtesy Light Response
Opener is initially plugged-in / Power restored	Flashes 5 times
Upon Opener activation	Turns on for 4-1/2 minutes and turns off automatically
"LEARN" button is pressed	Turns on for 30 seconds
Remote Control / Keyless Entry PIN code accepted	Flashes 5 times
The Photo Eye System is obstructed during door-closing or door is obstructed during opening	Flashes for 30 seconds (Re-align and clear obstruction)
Opener motor overheat (Thermal Protection)	Flashes 5 times (Wait about 15 minutes to cool down)

Manual Operation

WARNING

To Prevent SERIOUS INJURY or DEATH:

- Use Emergency Release to disconnect Trolley ONLY when the door is CLOSED to prevent unexpected rapid falling in case of a unbalanced / poor-conditioned door.
- Use Emergency Release ONLY when doorway is clear of persons and obstructions.
- DO NOT use Emergency Release to pull the door open or closed.

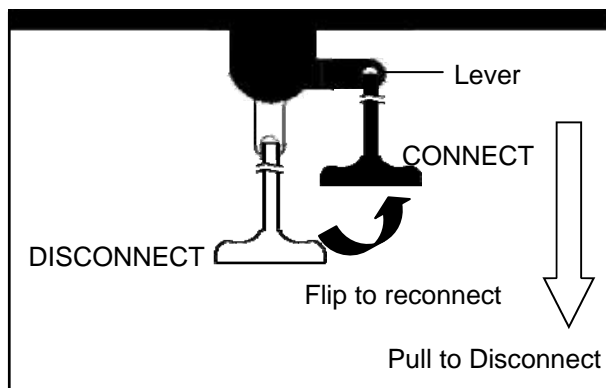

In case of a power failure or door obstruction, PULL EMERGENCY Handle to release door from Opener.

To Disconnect Trolley for Manual Operation

With the door closed, pull down the emergency release Handle to the DISCONNECT position. The door can be raised / lowered manually.

To Re-connect Trolley

Pull the Handle toward the Opener so that the lever will flip up to the CONNECT position. The Trolley will reconnect itself when the Opener is activated or when the door is manually opened/closed

Maintenance

Schedule	Maintenance
Once a month	Door balance test, refer to page 4. Safety reverse test, refer to page 17.
Twice a year	Check chain tension (refer to page 5 for adjustment if necessary).
Once a year	- Limit and Force adjustment may be necessary due to weather conditions. Refer to pages 15-16 for adjustment. Conduct Safety Reverse Test after ANY adjustments. - Lubricate door rollers, bearings and hinges. The Opener is permanently lubricated, DO NOT lubricate or grease the Opener, rail or door tracks.

Troubleshooting

Problem	Possible Cause / Solution
Opener does not close and light flashes	The Photo Eye may be obstructed, not properly aligned or installed, check connection and alignment referring to pages 12 & 14.
Opener does not respond to Remote Control	- Refer page 18 to reprogram Remote Control. - Check Remote Control battery
Opener stops before reaching full open / close position	Either the Travel Limit or Force is not properly adjusted, check adjustment referring to pages 15-16. Conduct Safety Reverse Test after ANY adjustment.
The door reverses unintentionally	- Make sure the Photo Eye Safety System is aligned and clear of obstructions. - Refer to page 4 to check the door balance - Refer to page 16-18 to re-adjust the force
The door reverses upon touching the floor and the courtesy light flashes	Refer to page 15 to decrease Close Limit by 1/4 turn until door stops as intended at the fully closed position. Conduct Safety Reverse Test after ANY adjustment.
The courtesy light flashes 5 times and the Opener does not start	Opener motor overheat, please wait about 15 minutes and retry.
The Opener does not close the door and the green LED on the Photo Eyes flashes	The Photo Eye Safety System is misaligned or obstructed, refer to page 14 for proper alignment.
The Opener is working properly but the courtesy light does not turn on	Replace light bulb (A19 incandescent Max.100W).
The courtesy light does not turn off	Defective Logic Board.

Note: If installing operators on two doors in the same garage, to ensure proper operation, Photo Eyes should be aligned as below:

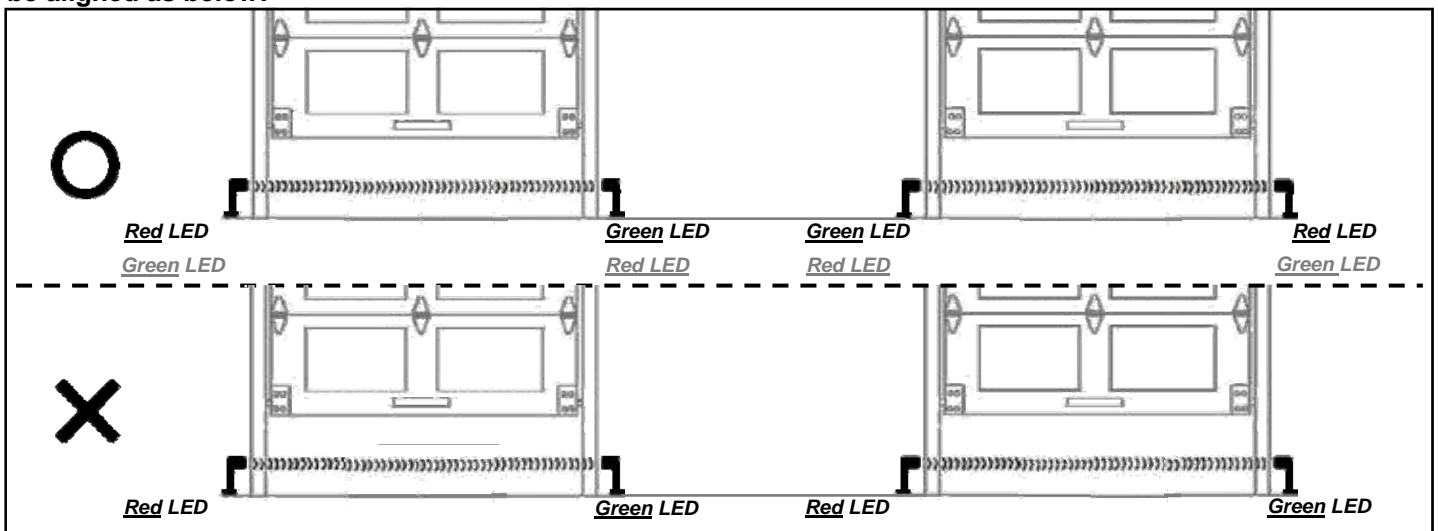

Repair Parts

Installation Parts

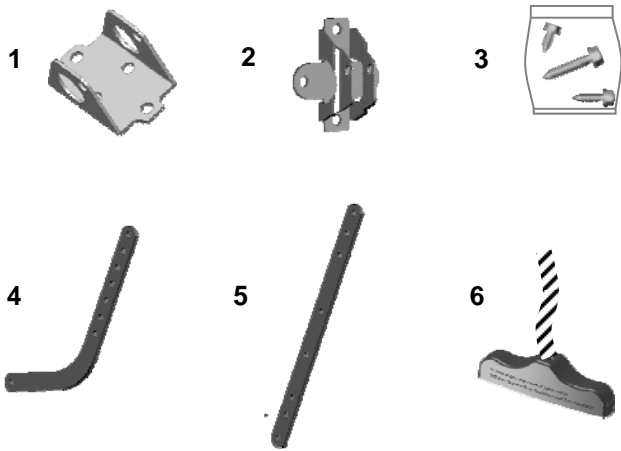

Item	Part No.	Name / Description
1	GUAT-027	Header Bracket
2	GUAT-022	Door Bracket
3	GUAT-023	Hardware Bag (Installation hardware shown on P.3)
4	GUAT-024	Curved Door Arm
5	GUAT-025	Straight Door Arm
6	GUAT-026	Emergency Release Handle & Rope

Accessories

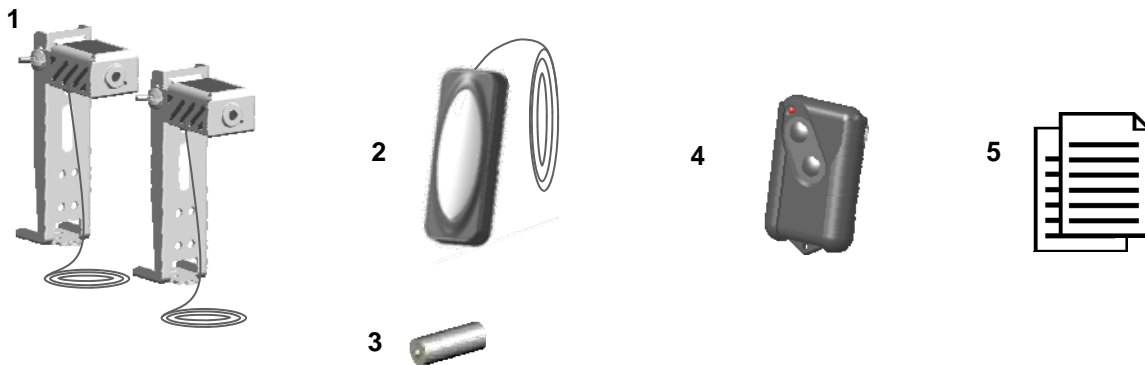

Item	Part No.	Name / Description
1	GUAT-201	Photo Eye Safety System (Emitter + Sensor with Brackets)
2	GUAT-202	Push button
3	GUAT-203	12V alkaline battery
4	R2BCC	Remote Control
5	GUAT-205	Owner's manual

Opener Assembly Parts

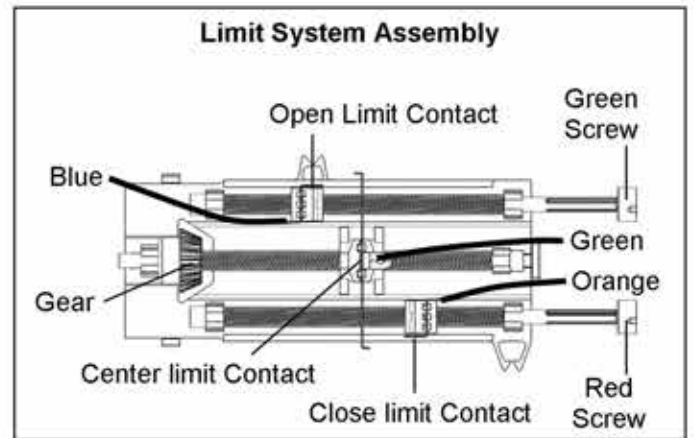
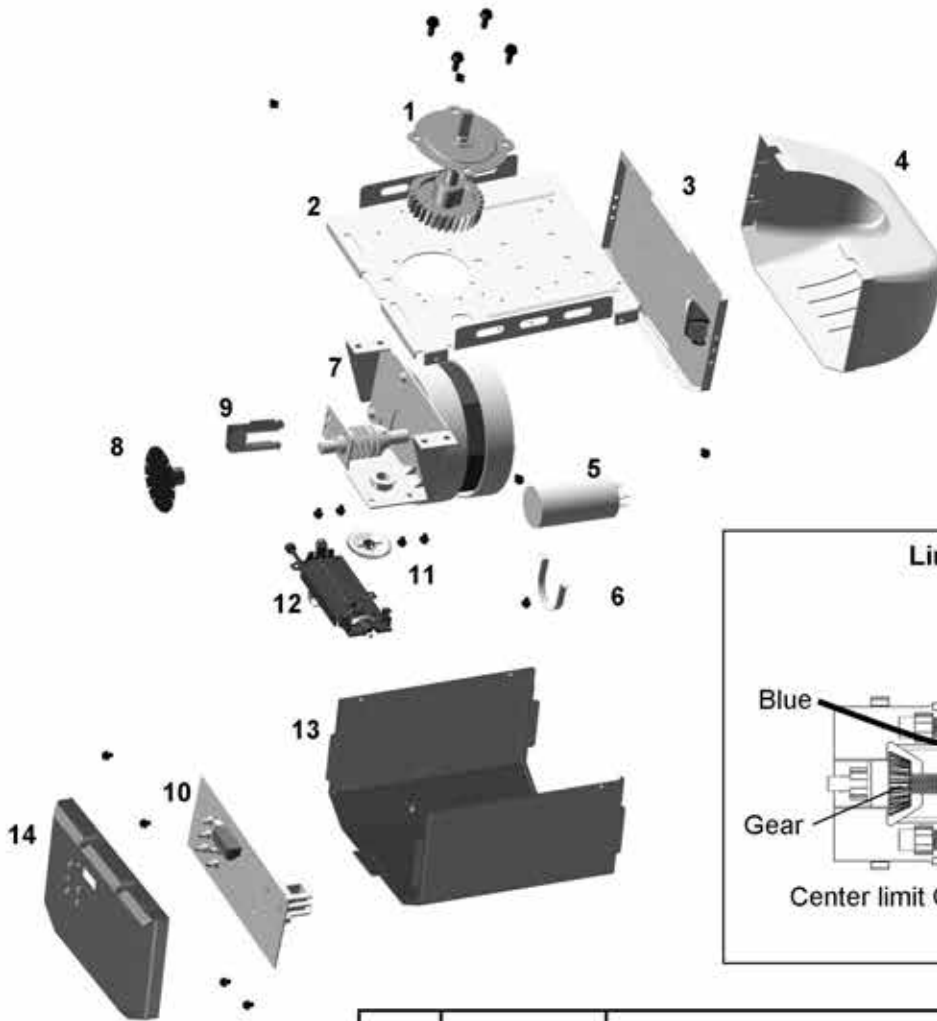

Item	Part No.	Name / Description
1	GUAT-301	Sprocket and gear assembly
2	GUAT-302	Chassis
3	GUAT-303	Lamp plate
4	GUAT-304	Lamp Dome
5	GUAT-305	Capacitor
6	GUAT-306	Capacitor holder
7	GUAT-307	Motor assembly
8	GUAT-314	RPM wheel
9	GUAT-315	RPM Reader Module
10	GUAT-316	Logic Board
11	GUAT-311	Limit system driving gear
12	GUAT-312	Limit system assembly
13	GUAT-317	Opener cover
14	GUAT-318	Back Panel

* Should be replaced by qualified technician only



WARRANTY

GARAGE DOOR OPERATORS

Manufacturer hereby warrants:

1. Garage Door Operators to be free from defects in material and workmanship for a period of five (5) years for motors and one (1) year for Electronics and Mechanics from date of purchase, if installed by an authorized reseller, otherwise if installed by the purchaser one (1) year will apply.
2. Garage Door Operators (Commercial and Industrial Application) to be free from defects in material and workmanship for a period of three (3) months from date of purchase.
3. Where the garage door operator has been returned to the manufacturer for Warranty repairs, all costs incurred in the return will be paid for by the purchaser. If in the opinion of the manufacturer the product is faulty, all defective parts will be replaced at no charge to the purchaser.
4. Proof of purchase must be given to the manufacturer at time of Warranty claim.
5. The manufacturer reserves the right to modify any existing or future products without incurring any obligation to incorporate such modification to products already manufactured or to which this Warranty may relate.
6. Warranty only applies if this product has been installed to the Manufacturers recommendation
7. This Warranty does not apply to any defect, loss or damage arising or caused directly or indirectly by or as a result of :
 - (i) Any defect (including defects in component parts or accessories) arising from or attributable to the failure to carry out normal preventive maintenance or adjustment itself.
 - (ii) To any additional damage or deterioration arising from attributable to the operation of the Operator after it is known to be defective.
8. Exclusions to Warranty Period:
 - (i) Repair or Warranty Work - three (3) month
9. Not included in Warranty:
 - (i) Batteries.
 - (ii) Fuses.
 - (iii) Light bulbs.
 - (iv) Sensitivity adjustment.
 - (v) Handheld Remote Controls and receiver range.
10. Note : All Warranties will be void subject to:
 - (i) Water damage and condensation.
 - (ii) Power supply black out or surge.
 - (iii) Act of God.
 - (iv) Modification or adjustment by unauthorized persons.
 - (v) Any interference from radio (including citizen band radios or and other electronic device)
 - (vi) Preventative maintenance and regular servicing not undertaken.
 - (vii) Account not paid in full by the purchaser.
11. Subject only to the provisions of the Trade practices Act and any legislation of the State or Territory wherein the operators of the Manufacturer have been sold or installed (which may confer certain rights on consumers of goods and those rights by such legislation may be rendered incapable of exclusion) this Warranty supersedes and excludes all representations, warranties and conditions whether expressed or implied by law and the Manufacturer shall have no liability or otherwise than herein provided for any loss and damage (including consequential loss and damage, loss of use or profits) by reasons of delay, defective or faulty materials or workmanship, negligence or any act, matter or thing done permitted or omitted to be done by the Manufacturer.

WARRANTY

THIS WARRANTY FORM SHOULD BE COMPLETED AT TIME OF INSTALLATION

This Warranty Form should be retained by the purchaser at all times and produced with the purchase docket by the Purchaser as proof of the purchase date.

PURCHASER'S NAME: _____

PURCHASER'S ADDRESS: _____

INSTALLED BY: _____

INSTALLER'S ADDRESS: _____

INSTALLER'S SIGNATURE: _____

SERIAL NUMBER OF THE OPERATOR: _____

GUARDIAN SERVICE

Your operator has been installed by a professional installation specialist. If service information is required please contact the installing company or your local Guardian dealer. Look for your Guardian dealer online, in the yellow pages or call our service number for a dealer near you.

Service number : **1-424-272-6998**

Please have the following information when you call:

- Model number of the operator
- Serial number of the operator--located on the bar code label on top of the opener, above the adjustment buttons



FCC Warning:

Any Changes or modifications not expressly approved by the party responsible for compliance could void the user's authority to operate the equipment.

Note: This equipment has been tested and found to comply with the limits for a Class B digital device, pursuant to part 15 of the FCC Rules. These limits are designed to provide reasonable protection against harmful interference in a residential installation. This equipment generates, uses and can radiate radio frequency energy and, if not installed and used in accordance with the instructions, may cause harmful interference to radio communications. However, there is no guarantee that interference will not occur in a particular installation. If this equipment does cause harmful interference to radio or television reception, which can be determined by turning the equipment off and on, the user is encouraged to try to correct the interference by one or more of the following measures:

- Reorient or relocate the receiving antenna.
- Increase the separation between the equipment and receiver.
- Connect the equipment into an outlet on a circuit different from that to which the receiver is connected.
- Consult the dealer or an experienced radio/TV technician for help.