

User's Manual for Cordless Telephone

GH2400



**Fold open this manual for information about this telephone s installation.
Please read the important Safety instructions included in your package.**

SOUTHWESTERN BELL FREEDOM PHONE

7475 North Glen Harbor Boulevard, Glendale, AZ 85307

GH2400 Printed in Korea

IMPORTANT SAFETY INSTRUCTIONS

BEFORE USING YOUR TELEPHONE EQUIPMENT, BASIC SAFETY PRECAUTIONS SHOULD ALWAYS BE FOLLOWED TO REDUCE THE RISK OF FIRE, ELECTRIC SHOCK AND INJURY TO PERSONS, INCLUDING THE FOLLOWING:

1. Read and understand all instructions.
2. Follow all warnings and instructions marked on the product.
3. Unplug this product from the wall telephone jack and power outlet before cleaning. Do not use liquid cleaners or aerosol cleaners. Use damp cloth for cleaning.
4. Do not use this product near water; for example, near a bathtub, wash bowl, kitchen sink, laundry tub, swimming pool, or in a wet basement.
5. Do not place this product on an unstable cart, stand or table. The product may fall, causing serious damage to the product.
6. Slots or openings in the cabinet and the back and bottom are provided for ventilation, to protect it from overheating. These openings must not be blocked or covered. The openings should never be blocked by placing the product on the bed, or other similar surface. This product should never be placed near or over a radiator or heat register. This product should not be placed in a built-in installation unless proper ventilation is provided.
7. This product should be operated only from the type of power source indicated on the marking label.
If you are not sure of the type of power supply to your home, consult your dealer or local power company.
8. Do not allow anything to rest on the power cord. Do not locate this product where the cord will be damaged by persons walking on it.
9. Do not overload wall outlets extension cords, as this can result in fire or electric shock.
10. Never push objects of any kind into this product through cabinet slots, as they may touch dangerous voltage points or short out parts. This could result in fire or electric shock.
Never spill liquid of any kind on this product.
11. To reduce the risk of electric shock, do not disassemble this product.
Instead, when some repair work is required, take the unit to a qualified technician. Opening or removing covers may expose you to dangerous voltages or other risks.
Incorrect reassemble can cause electric shock when the appliance is subsequently used
12. Unplug this product from the wall outlet and refer servicing to qualified service personnel under the following conditions:
 - a. When the power supply cord or plug is damaged or frayed.
 - b. If liquid has been spilled into the product.

- c. If the product has been exposed to rain or water.
 - d. If the product does not operate normally and proper operating instructions have been followed, adjust only those controls that are covered by the operating instructions. Improper adjustment of other controls may result in damage and will often require extensive work by a qualified technician to restore the product to normal operation.
 - e. If the product has been dropped or cabinet has be damaged.
 - f. If the product exhibits a distinct change in performance.
13. Avoid using telephone (other than a cordless type) during an electrical storm. There may be a remote risk of electrical shock from lightning.
14. Do not use the telephone to report a gas leak in the vicinity of the leak.

SAVE THESE INSTRUCTIONS CAUTION:

SAFETY INSTRUCTIONS FOR BATTERIES

CAUTION :

To reduce the risk of fire or personal injury, read and follow these instructions

1. Use only a **Southwestern Bell Freedom Phone** approved battery pack in the handset of your cordless telephone. FOR HANDSET UNIT:

3N-600AAAL 3.6V 550mAh JALI Co., Ltd or GP60AAAS3BMX 3.6V 550mA GPI INTERNATIONAL LIMITED.

2. Do not dispose of the battery in a fire, as it may explode. Check with local codes for possible special disposal instructions.

3. Do not open or mutilate the battery.

Released electrolyte is corrosive and may cause damage to the eyes and skin. It may be toxic if swallowed.

4. Exercise care in handling batteries in order not to short the battery with conducting materials such as rings, bracelets and keys. The battery or conduction material may overheat and cause burns.

5. Charge the battery (ies) provided with or identified for use with this product only in accordance with the instructions and limitations specified in this manual.

6. Observe proper polarity orientation between the Battery Pack and battery charger

The RBRC TM Seal on the nickel-cadmium (Ni-C D) battery indicates that

Southwestern Bell Freedom Phone

Retail Sales is voluntarily participating in a program to collect and recycle these batteries at the end of their useful life, when taken out of service within the United States.

Please call the RBRC TM, toll-free at 1-800-8- BATTERY or contact your local recycling center for information on where to return the spent battery.

CONTAINS NICKEL-CADMIUM BATTERY. BATTERY MUST BE RECYCLED OR DISPOSED OF PROPERLY.

BRC TM is a trademark of the Rechargeable Battery Recycling Corporation

FCC WANTS YOU TO KNOW

This equipment complies with Part 68 of the FCC rules. On the bottom of the base of this equipment is a label that contains, among other information, the FCC Registration Number, Ringer Equivalence number (REN) and the Universal Service Order Code (USOC), which is RJ-11C, for this equipment. You must, upon request, provide this information to your telephone company.

The REN is useful to determine the quantity of devices you may connect to your telephone line and still have all of those devices ring when your telephone number is called. In most, but not all areas, the sum of the RENs of all devices connected to one line should not exceed five (5.0). To be certain of the number of devices you may connect to your line, as determined by the REN, you should contact your local telephone company to determine the maximum REN for your calling area.

If your telephone equipment causes harm to the telephone network, the telephone company may discontinue your service temporarily. If possible, they will notify you in advance. But if advance notice isn't practical, you will be notified as soon as possible. You will be informed of your right to file a complaint with FCC.

Your telephone company may make changes in its facilities, equipment, operations, or procedures that could affect the proper functioning of your equipment. If they do, you will be notified in advance to give you an opportunity to maintain uninterrupted telephone service. If you experience trouble with this telephone equipment, disconnect from the network until the problem has been corrected or until you are sure that the equipment is not malfunctioning.

This equipment may not be used on coin service provided by the telephone company. Connection to party lines is subject to state tariffs.

WARNING: Changes or modifications to this unit not expressly approved by the party responsible for compliance could void the user's authority to operate the equipment.

NOTE: This equipment has been tested and found to comply with the limits for Class B digital device, pursuant to Part 15 of the FCC Rules. These limits are designed to provide reasonable protection against harmful interference in a residential installation.

Some cordless telephones operate at frequencies that may cause interference to nearby TV's and VCR's. To minimize or prevent such interference, the base of the cordless telephone should not be placed near or on top of a TV or VCR; and, if interference is experienced, moving the Cordless Telephone farther away from the TV or VCR will often reduce or eliminate the interference.

NOTICE TO HEARING AID WEARERS:

This Cordless Telephone has been registered with the FCC as hearing aid compatible.

However, there is no guarantee that interference will not occur in a particular installation.

If this equipment does cause harmful interference to radio or television reception, which can be determined by turning the equipment off and on, the user is encouraged to try to correct the interference by one or

more of the following measures:

- Reorient or relocate the receiving antenna.
- Increase the separation between the equipment and receiver.
- Connect the equipment into an outlet on a circuit different from that to which the receiver is connected.
- Consult the dealer or an experienced radio TV technician for help.

LIMITED WARRANTY

This **Southwestern Bell Freedom Phone** is warranted to the original purchaser to be free from defects in materials and workmanship under normal installation, use and service for a period of one (1) year from the date of purchase as shown on the purchaser's receipt.

The obligation of **Southwestern Bell Freedom Phone Retail Sales** under this warranty shall be limited to repair or replacement (at our option) during the warranty period of any part which proves defective in material or workmanship under normal installation, use, and service, provided the product is returned to **Southwestern Bell Freedom Phone Retail Sales** TRANSPORTATION CHARGES PREPAID (California residents call 1-800-366-0937 for shipping instructions). If we choose to replace your

Southwestern Bell Freedom Phone product, the replacement will be warranted for either

- (a) 90 days or (b) the remainder of the original one year warranty period, whichever is longer.
- (b) Battery packs are warranted for the same time period.

Products returned to us must be accompanied by a copy of the purchase receipt. In the absence of such Purchase receipt, the warranty period shall be one (1) year from the date of manufacture.

To obtain service under this warranty, return the defective product to the service center nearest you together with your sales slip and \$9.50 for postage and handling (California residents need only provide proof of purchase).

This warranty shall be invalid if the product is damaged as a result of defacement, misuse, abuse, neglect, accident, destruction, or alteration of the serial number, improper electrical voltages or currents, repair alteration or maintenance by any person or party other than our own service facility or an authorized Service Center, or any violation of instructions furnished by us.

This warranty is also rendered invalid if this product is removed from the country in which it was purchased, if it is used in a country which it is not registered for use, or if it is used in a country for which it was not designed. Due to variations in telephone systems and communications laws, this product may be illegal for use in some countries.

Southwestern Bell Freedom Phone Retail Sales assumes no responsibility for damages or penalties incurred resulting from the use of this product in a manner or location other than that from which it is intended.

This one-year limited warranty is in lieu of all other express warranties, obligations, or liabilities.

ANY IMPLIED WARRANTIES, OBLIGATIONS, OR LIABILITIES, INCLUDING BUT NOT LIMITED TO THE IMPLIED WARRANTIES OF MERCHANTABILITY AND FITNESS FOR A PARTICULAR PURPOSE, SHALL BE LIMITED IN DURATION TO THE ONE-YEAR DURATION OF THIS WRITTEN LIMITED WARRANTY. SOME STATES DO NOT ALLOW LIMITATIONS ON HOW LONG AN IMPLIED WARRANTY LASTS, SO THE ABOVE LIMITATIONS MAY NOT APPLY TO YOU. IN NO EVENT SHALL WE BE LIABLE FOR ANY SPECIAL, INCIDENTAL OR CONSEQUENTIAL DAMAGES FOR BREACH

OF THIS OR ANY OTHER WARRANTY, EXPRESSED OR IMPLIED, WHATSOEVER.

This warranty gives you specific legal rights, and you may also have other rights which vary from state to state.

OPERATION

50-Channel Operation

The GH2400 cordless telephone automatically searches and selects the clearest of 50 channels when it is being used.

Voice Scramble

The GH2400 protects your privacy by encoding the voice signal between the handset and base unit when you make or receive calls. With this voice scramble feature, It's difficult or impossible for some one to intercept and understand your calls.

Security Code

The security code prevents your cordless telephone conversation from being accessed by a phone on a different line.

Once the handset battery is fully charged, the handset will automatically select the code from a total of over 65,000 combinations. The code is changed every time the handset is placed in the cradle.

If you experience difficulty with placing or receiving calls, a lost security code may be the cause of the problem. When this occurs, the handset can no longer communicate with the base.

Reset by placing handset on base for 5-10 seconds. If that does not work, unplug the AC adaptor from the wall outlet.

Disconnect the handset battery for 5-10 seconds, then reconnect. Place handset back on base and then replug the AC adaptor.

Lighted Keypad

The lighted keypad allows for better visibility when dialing in a dimly lit room.

The keypad will remain lit for 10 seconds after any button is pushed, or when a call is received.

Placing a Call

1. Press **TALK** button.
2. **TALK LED** on handset will light.
3. When you hear a dial tone, place your call.
4. While on a call, if you experience noise or static:
 - a. Press **CH**(Channel) button on handset until a clear channel is found; the call will not be interrupted.

Or

- b. Move closer to base.

Note: You must be in usable range to change channels. Base antenna should be in upright position.

Receiving a Call

1. IF THE HANDSET IS OUT OF THE BASE UNIT, press **TALK** or any button on the keypad.
2. IF THE HANDSET IS IN THE BASE UNIT, lift the handset.

Do not press **TALK**. You will automatically be connected.

Ending a Call

1. Place the handset in the base or press **TALK** to be disconnected from the line.
3. **TALK LED** on handset will turn off.

Flash

Use the **FLASH** button to activate custom calling services such as Call Waiting or Three-Way Calling (*Special subscription from your local telephone company required).

Temporary Tone(*)

Pulse (rotary) service users may access touch-tone features needed to operate answering machines or use electronic banking, calling cards, etc., by pressing the TONE (*) button.

Phone will automatically return to pulse dialing after the call ends.

Out of Range

If you experience static while using the telephone, move closer to the base or change the channel by pressing the **CH**(Channel) button.

Redial

Last number dialed (up to 32 digits) is stored in redial memory until another number is dialed.

1. Press **TALK** on handset.
2. When you hear a dial tone, press **REDIAL**.

Pause

A 4-second pause may be inserted into the speed dialing of telephone numbers.

Press **REDIAL** button at required point during storage of a number in memory.

INSTALLATION

CAUTION

1. Never install a telephone during a lightning storm.
2. Never install a telephone in a wet location.
3. Never touch uninsulated telephone wires or terminals .
4. Use caution when installing a telephone line.

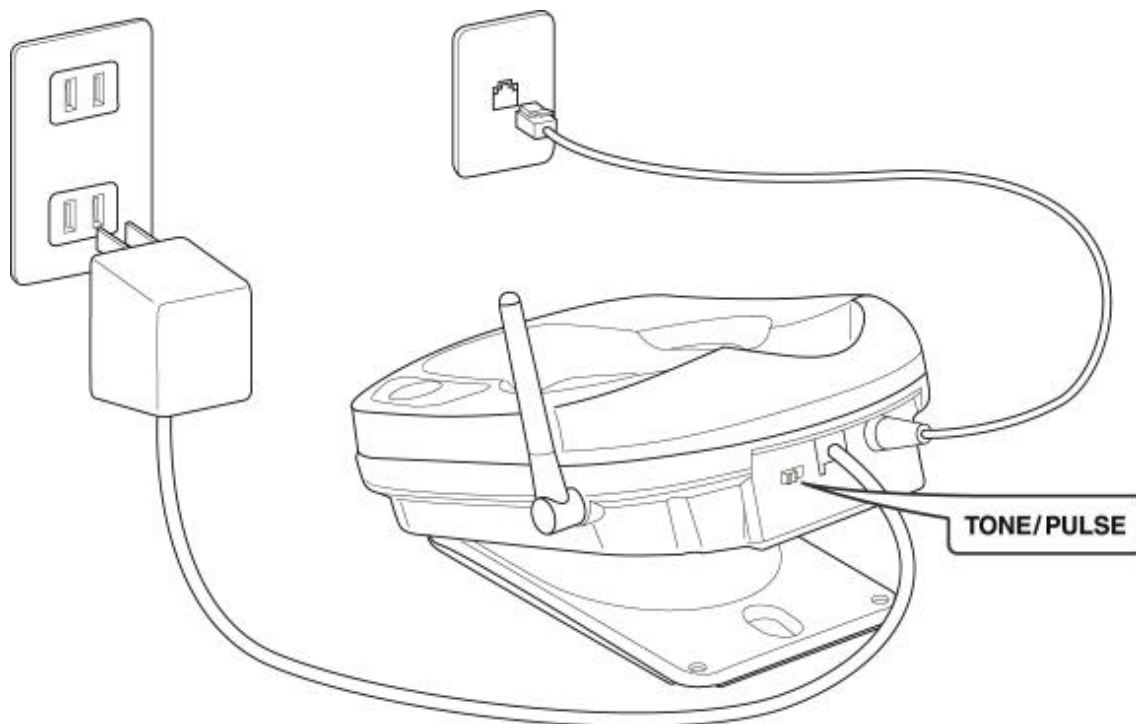

120 Volt Outlet / Telephone Jack

1. This phone requires a modular phone jack (RJ11) and a standard 120 volt outlet.
2. Plug phone directly into outlet.
3. Do not plug other appliances into outlet or have outlet controlled by a wall switch.

Wall Mount Installation

Base unit may be mounted on a standard wall plate.

1. To connect the Desk/Wall bracket in the wall mount position, align the bracket with the slots on the base

until it is securely in place.

2. Insert AC adaptor into back of base unit.
3. Insert one end of short line cord into back of base unit, passing line cord through the groove.
4. Plug other end of line cord into modular jack.
5. Mount base on wall plate studs and gently press until the unit locks in place.
6. Plug AC adaptor directly into standard 120 volt outlet.

Desk Top Installation

1. To connect the Desk/Wall mount bracket in the desk/table position align the bracket with the slots on the base until it is securely in place.
2. Plug one end of line cord into back of base unit.
3. Plug other end of line cord into modular jack.
4. Press until locking lever clicks.
5. Connect AC adaptor into back of unit and plug directly into standard 120 volt outlet.

Antennas

Adjust base antenna to upright position.

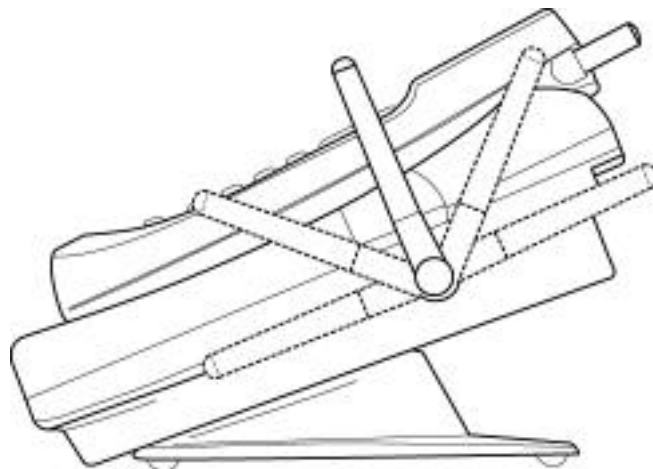

Set Tone/Pulse Switch

Set switch (back of base) to correct dialing mode **TONE** or **PULSE**.

Please check with local phone company if uncertain of type of service.

Ringer On/ Off

Set switch (left side of handset) to **ON** or **OFF**. Ringer switch must be ON for handset to ring during incoming calls.

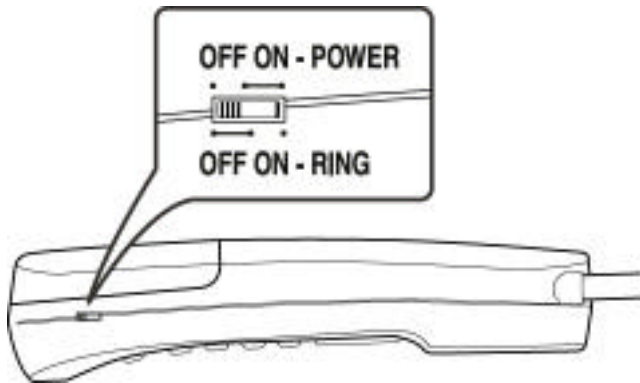

Receiver Volume Control

Adjust the receiver volume from low (|) to high (|)

Handset Battery Charging

The battery pack in the handset must be fully charged 10-14 hours before using the telephone for the first time.

1. Place handset in base. The **CHARGE LED** on base will light.
2. After batteries are fully charged, check for dial tone by pressing **TALK** on handset.
4. When handset battery gets low, there will be 2 beeps every 30 seconds.

The **TALK BUTTON** will flash. Return to cradle for charging.

5. If battery becomes low while you are on a call, you will be disconnected after about 2 minutes.

Terminate the call quickly and recharge battery.

To recharge battery pack, place handset in base and:

1. Make sure contact points are touching and **CHARGE LED** is lit.
2. Be careful not to short battery with conducting materials such as rings, bracelets and keys.

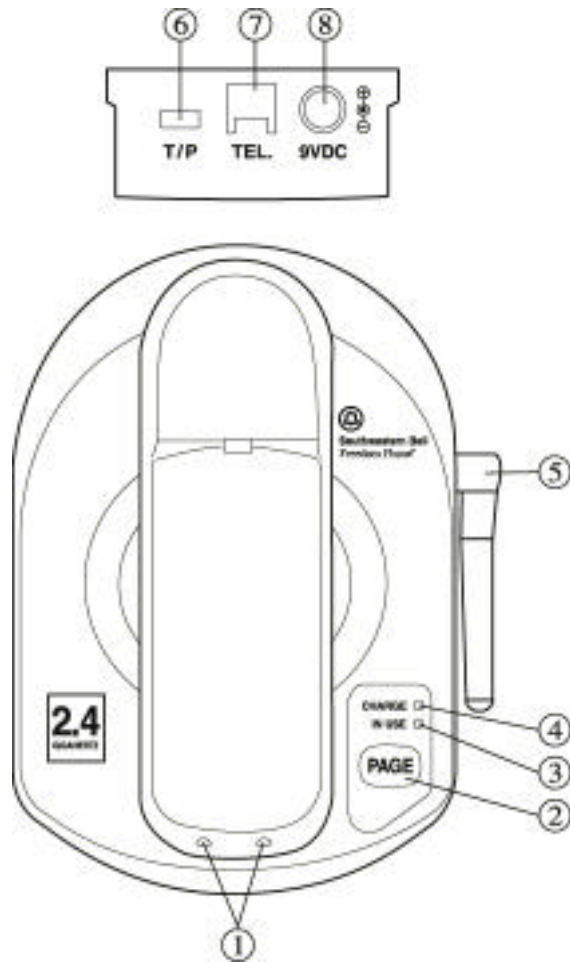

1. Charging contact
2. Page button
3. In-use lighting
4. Charging Lighting
5. Antenna
6. Tone/Pulse switch
7. Modular Jack
8. DC Jack

Dual Charge (Desk installation Only)

The GH2400 is specially designed with a dual charge feature. The battery pack will charge whether the handset is placed on the base facing up OR facing into the base.

Replace battery every 2 years. Use only a Southwestern Bell Freedom Phone approved Ni-MH battery in your cordless phone.

To Replace Battery:

1. Remove battery cover.

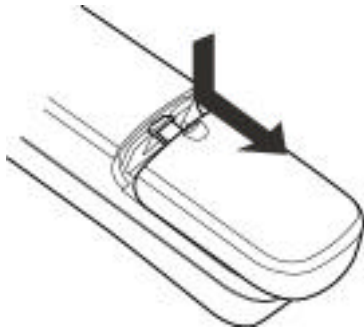

2. Install new battery.

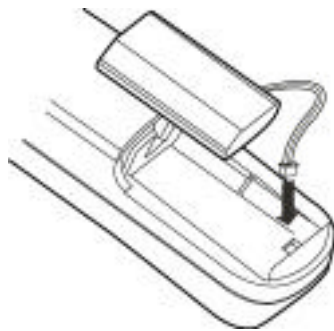

3. Close battery cover. Charge
10-14 hours before first use.

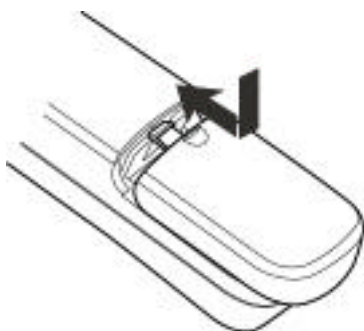

Page / Handset Locator

Send a signal from the base to handset.

Press **PAGE** button on base and a series of rings will sound from handset.

To locate the handset (it if is away from the base), press and hold **PAGE** button.

press any key on keypad (including **TALK**) to cancel the page.

Memory Feature

Store up to 10 numbers in memory for quick dialing.

To Program Frequently Called Numbers

1. Pick up handset, with **TALK** off.
2. Press **MEMO** (Memory) button.
3. Dial phone number (up to 16 digits).
4. Press **MEMO** button again.
5. Press a number key (0-9) for the memory location where the number is to be stored.
6. A series of quick beeps will confirm the number has been successfully stored.
7. Record numbers to be speed dialed on memory index label, which can be adhered to the base or other desired locations.

Note: If a 17th digit is accidentally pressed or a pause of more than 30 seconds occurs during programming, an error tone will sound. Try again. Each **TONE(*)** or **Pause** button entered uses one of the 16 available memory digits.

Change a Stored Number

Replace a stored number by programming a new number in its place.

Dialing a Number Stored in Memory

1. Lift handset. Press **TALK**.
2. With **TALK** button lit, press **MEMO**.
3. Press memory location (0-9) assigned to number being called.

i i i i i i i i

i i i

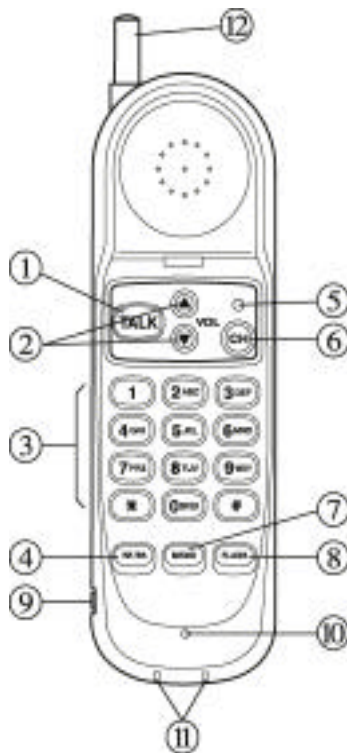

1. **TALK BUTTON** : Lights to indicated line is in use.
2. **Receiving Volume Control** : Adjust Listening level from Norm to High.
3. **Temporary Tone(*) Button** : Press to temporarily change the dialing mode from pulse to lone.
4. **REDIAL Button** : Press to redial the last number you called or inset a 4 seconds pause into the speed dialing of telephone numbers.
5. **Ringer On/Off** : Set the phone to RINGER ON or RINGER OFF.
6. **IN USE/LOW BATT LED** : Lighting of green LED to indicate line is in use or lighting of red LED to indicate battery is empty.
7. **Handset Jack** : Connect a headset(not included) for hands-free conversations.
8. **Channel Button**: Press to change the operating channel when you hear interference.
9. **Memo(Memory) Button** : Press to store phone numbers in memory or to call a number you have stored.
10. **Flash Button** : Press to answer an incoming call if you have Call Waiting.
11. **Microphone**
12. **Charging contacts** : For charging the battery in the HANDSET.
13. **Antenna**

Headset Jack

You can connect a handset(not included) for hands-free conversations.

1. Inset the headset's plug (must be 3/32 inch/2.5mm type) into the headset jack on the side of the handset.
2. Attach the belt clip to the back of the handset and the desired location on your clothing.
3. Adjust the microphone to a comfortable position, placing it near your mouth.
4. Use the **TALK** button to make or receive a call.
5. To remove the belt clip from the back of the handset, press and slide down the belt clip. Then slide up the latch on the back of the handset.

TROUBLESHOOTING

If you experience difficulty operating your cordless phone, try the suggestions below.

If the trouble persists, call the Southwestern Bell Freedom Phone ™ Retail Sales Toll Free Help Line at 1-800-366-0937, Monday –Friday between the hours of 8:30 a.m.-4:30 p.m. (EST), or visit our web site at <http://www.swbfreedomphone.com>.

The unit will not operate / no dial tone:

- Make sure TALK LED is lit.
- Make sure AC adaptor is plugged into base unit and wall outlet.
- Make sure telephone line cord is plugged into wall jack.
- Make sure base antenna is in upright position.
- Make sure handset battery is fully charged.
- Make sure you have selected correct dialing mode, tone (touch) or pulse (rotary).
- Make sure you are within usable range of the base station.
- Reset security code by placing handset in base for 5-10 seconds.

The phone does not ring when you receive a call:

- Make sure the RINGER switch on left side of handset is turned to ON.
- Make sure AC adaptor is plugged into base unit and wall outlet.
- Make sure telephone line cord is plugged into wall jack.
- Make sure you are within usable range of the base station.
- You might have too many extension phones on your line. Try unplugging a few.

Noise, static, interference or other calls heard while using handset:

- Try changing channels.
- Make sure base antenna is in upright position.
- Make sure you are within usable range of the base station.
- Make sure AC adaptor is not plugged into wall outlet with other appliances.
- Try relocating base unit to another location.
- Make sure handset battery is fully charged.

Phone will not hold charge:

- Make sure charging contacts on the handset and base are free of dust and dirt. Clean contacts with a soft cloth.

- Make sure CHARGE LED on base is lit when handset is in cradle.
- If necessary, replace handset battery. (See Handset Battery Charging)

Difficulty in placing or receiving calls:

- Move closer to base and try again.
- If moving closer doesn't work, you may have lost security code. Reset code by placing handset back on base for 5-10 seconds. (See Security Code section)
- Make sure you have selected correct dialing mode, tone or pulse.
- Make sure AC adaptor is not plugged into wall outlet with other appliances.
Disconnect for 5-10 seconds then reconnect. Place handset back on base and then replugin AC adaptor.
- Make sure handset battery is fully charged.
- If using a headset(not included), make sure you are using a headset that has a 3/32 inch (2.5mm) plug.
Make sure the microphone is placed near your mouth.

STOP | -don't take unit back to the store.

LOOK | -for the toll- free "help" telephone number

LISTEN | -as our experts talk you through the problem

For immediate answers to your questions regarding operation,
missing parts or installation, call the

Southwestern Bell Freedom Phone

Retail Sales Help Line:

1- 800- 366- 0937

8: 30 a. m. - 4: 30 p. m. EST, Monday through Friday

<http://www.swbfreedomphone.com>