



GS1500M

LOW-POWER WIRELESS SYSTEM-ON-CHIP WI-FI MODULE

--- USER'S MANUAL ---

PRELIMINARY RELEASE

GainSpan Confidential Information

Reference: GS1500M-DS

Version: SP-0.1

Date: 11-Oct-11

Information in this document is provided in connection with GainSpan products. No license, express or implied, to any intellectual property rights is granted by this document. GainSpan assumes no liability whatsoever, and disclaims any express or implied warranty, relating to sale and/or use of GainSpan products including liability or warranties relating to fitness for a particular purpose, merchantability, or infringement of any patent, copyright or other intellectual property right. GainSpan products are not authorized for use as critical components in medical, life saving, or life-sustaining applications

GainSpan may make changes to specifications and product descriptions at any time, without notice.

*Other names and brands may be claimed as the property of others.

Copyright © 2011 by GainSpan Corporation
All Rights Reserved.

GainSpan Corporation
 125 South Market Street, Suite 400
 San Jose, CA 95113
 U.S.A.

+1 (408) 673-2900

info@GainSpan.com
 www.GainSpan.com

Version	Date	Remarks
0.1	12-Apr-11	Initial Release

Table of Contents

1	Overview	7
1.1	Document Overview.....	7
1.2	Product Overview.....	7
2	Architecture	9
2.1	G1500M Block Diagram.....	9
2.2	Block Diagram Description.....	9
2.2.1	Overview	9
2.2.2	Wireless LAN and System Control Subsystem.....	10
2.2.3	Network Services Subsystem.....	10
2.2.3.1	APP CPU	10
2.2.4	Memory Subsystem.....	10
2.2.4.1	Overview.....	10
2.2.5	Clock Circuitries	11
2.2.5.1	Real Time Clock (RTC).....	11
2.2.5.2	Overview.....	11
2.2.5.3	Real Time Counter.....	12
2.2.5.4	RTC Outputs	12
2.2.5.4.1	DC_DC_CNTL.....	13
2.2.5.4.2	RTC_OUT1.....	13
2.2.5.5	RTC Alarm Inputs 1 and 2.....	13
2.3	Peripherals.....	13
2.3.1	SPI.....	13
2.3.2	I ² C	14
2.3.3	UART.....	15
2.3.4	JTAG.....	15
2.3.5	GPIO & LED Driver / GPIO.....	16
2.3.6	ADC	16
2.4	System States.....	17
3	Pin-out and Signal Description.....	19
3.1	GS1500M Device Pin-out Diagram (Module top view)	19
3.1.1	GS1500M Module Pins Description	20
4	Electrical Characteristics	24
4.1	Absolute Maximum Ratings.....	24
4.2	Operating Conditions	24
4.3	Internal 1.8V regulator	24
4.4	I/O DC Specifications	25
4.4.1	Digital Input Specifications.....	25
4.4.2	Digital Output Specification	25
4.4.3	I/O Digital Specifications (Tri-State).....	25
4.4.4	RTC Input Specifications (with Schmitt Trigger).....	26
4.4.5	RTC Output Specifications	26
4.5	Power Consumption (estimated)	27
4.6	Radio Parameters.....	27
4.7	ADC Parameters.....	28
4.8	SPI Interface Timing	29
4.8.1	Motorola SPI, clock polarity SPO = 0, clock phase SPH = 0	29
4.8.2	Motorola SPI, clock polarity SPO = 0, clock phase SPH = 1	31

4.8.3 Motorola SPI, clock polarity SPO = 1, clock phase SPH = 0 33

4.8.4 Motorola SPI, clock polarity SPO = 1, clock phase SPH = 1 35

4.9 Electrostatic discharge (ESD) 36

5 Package and Layout Guidelines 37

5.1 GS1500M Recommended PCB Footprint and Dimensions 37

6 Ordering Information..... 39

7 Regulatory Notes 40

8 Limitations..... 42

9 References 43

PRELIMINARY

Figures

Figure 2-1: GS1500M Block Diagram	9
Figure 2-2: RTC Interface Diagram	12
Figure 2-3: GS1500M System States	17
Figure 3-1: GS1500M Device Pin-out Diagram (Module top view).....	19
Figure 3-2: Module pin connection diagram	23
Figure 4-1: timing diagram, Master mode, SPO=SPH=0.....	29
Figure 4-2: timing diagram, Slave mode, SPO=SPH=0.....	30
Figure 4-3: timing diagram, Master, SPO=0, SPH=1.....	31
Figure 4-4: timing diagram, Slave, SPO=0, SPH=1.....	32
Figure 4-5: timing diagram, Master mode, SPO=1, SPH=0.....	33
Figure 4-6: timing diagram, Slave mode, SPO=1, SPH=0.....	34
Figure 4-7: timing diagram, Master mode, SPO=SPH=1.....	35
Figure 4-8: timing diagram, Slave mode, SPO=SPH=1.....	36
Figure 5-1: GS1500M Module Recommended PCB Footprint (dimensions are in inches).....	37
Figure 5-2: GS1500M Module Dimensions (in inches).....	38

Tables

Table 3-1: Signal Description.....	22
Table 4-1: Absolute Maximum Ratings	24
Table 4-2: Operating Conditions	24
Table 4-3: Internal 1.8V Regulator	24
Table 4-4: Digital Input Parameters	25
Table 4-5: Digital Output Parameters.....	25
Table 4-6: I/O Digital Parameters	26
Table 4-7: RTC Input Parameters.....	26
Table 4-8: RTC Output Parameters	26
Table 4-9: Power Consumption in Different States.....	27
Table 4-10: Radio Parameters	27
Table 4-11: ADC Parameters	28
Table 4-12: timing parameters, Master mode, SPO=SPH=0.	29
Table 4-13: timing parameters, Slave mode, SPO=SPH=0.....	30
Table 4-14: timing parameters, Master mode; SPO=0, SPH=1.	31
Table 4-15: timing parameters, Slave mode, SPO=0, SPH=1.....	32
Table 4-16: timing parameters, Master mode, SPO=1, SPH=0.....	33
Table 4-17: timing parameters, Slave mode, SPO=1, SPH=0.....	34
Table 4-18: timing parameters, Master mode, SPO=SPH=1.	35
Table 4-19: timing parameters, Master mode, SPO=SPH=1.	36

1 Overview

1.1 Document Overview

THIS DOCUMENT describes the GS1500M Low Power module hardware specification. The GS1500M module provides a cost effective, low power, and flexible platform to add Wi-Fi® connectivity for embedded devices for a variety of applications, such as wireless sensors and thermostats. It combines ARM7-based processors with an RF transceiver, 802.11 MAC, security, & PHY functions, FLASH and SRAM, onboard and off module certified antenna options, and various RF front end options for end customer range needs in order to provide a WiFi and regulatory certified IEEE 802.11 radio with concurrent application processing services for variety of applications, while leverage existing 802.11 [1] wireless network infrastructures.

1.2 Product Overview

- ▶ Family of modules with different antenna and output power options:
 - GS1500M 1.450 inches by 0.900 inches by 0.143 inches (Length * Width * Height) 48-pin Dual Flat pack PCB Surface Mount Package.
 - Simple API for embedded markets covering large areas of applications
- ▶ Compliant with IEEE 802.11 and regulatory domains:
 - Fully compatible with IEEE 802.11b/g/n.
 - DSSS modulation for data rate of 1 Mb/s and 2 Mb/s; CCK modulation rates of 5.5 and 11 Mb/s.
 - OFDM modulation for data rates of 6, 9, 12, 18, 24, 36, 48 and 54 Mb/s.
 - 802.11n 1x1 HT20 for data rates of MCS0 – 7.
 - Supports short preamble and short slot times.
 - WiFi Certified Solution
 - Supports 802.11i security
 - WPA™ - Enterprise, Personal
 - WPA2™ - Enterprise, Personal
 - Vendor EAP Type(s)
 - EAP-TTLS/MSCHAPv2, PEAPv0/EAP-MSCHAPv2, PEAPv1/EAP-GTC, EAP-FAST, EAP-TLS
 - Hardware encryption/decryption engines for WEP, WPA/WPA2 (AES and TKIP)
 - RoHS and CE compliant
 - FCC/IC Certified - TBD
- ▶ Dual ARM7 Processor Platform:
 - 1st ARM7 processor (WLAN CPU) for WLAN software
 - 2nd ARM7 (APP CPU) for networking software
 - Based on Advanced Microprocessor Bus Architecture (AMBA) system:
 - AMBA High-Speed Bus (AHB).
 - AMBA Peripheral Bus (APB).
 - On-chip WLAN boot code located in dedicated boot ROM.

- ▶ Interfaces:
 - PCB or external antenna options.
 - Two general-purpose SPI interfaces (each configurable as master or slave) for external sensors, memory, or external CPU interface; one interface may be configured as a high-speed Slave-only.
 - Two multi-purpose UART interfaces.
 - Up to 23 configurable general purpose I/Os.
 - Single 3.3V supply option
 - I/O supply voltage 1.8 ~ 3.3V option
 - One PWM output
 - I²C master/slave interface.
 - Two 10-bit ADC channels, aggregate sample rate 32 kS/s.
 - Two alarm inputs to asynchronously awaken the chip.
 - Support of up to two control outputs for power supply and sensors.
- ▶ Embedded RTC (Real Time Clock) can run directly from battery.
- ▶ Power supply monitoring capability.
- ▶ Low-power mode operations
- ▶ Sleep and Deep Sleep

2 Architecture

2.1 G1500M Block Diagram

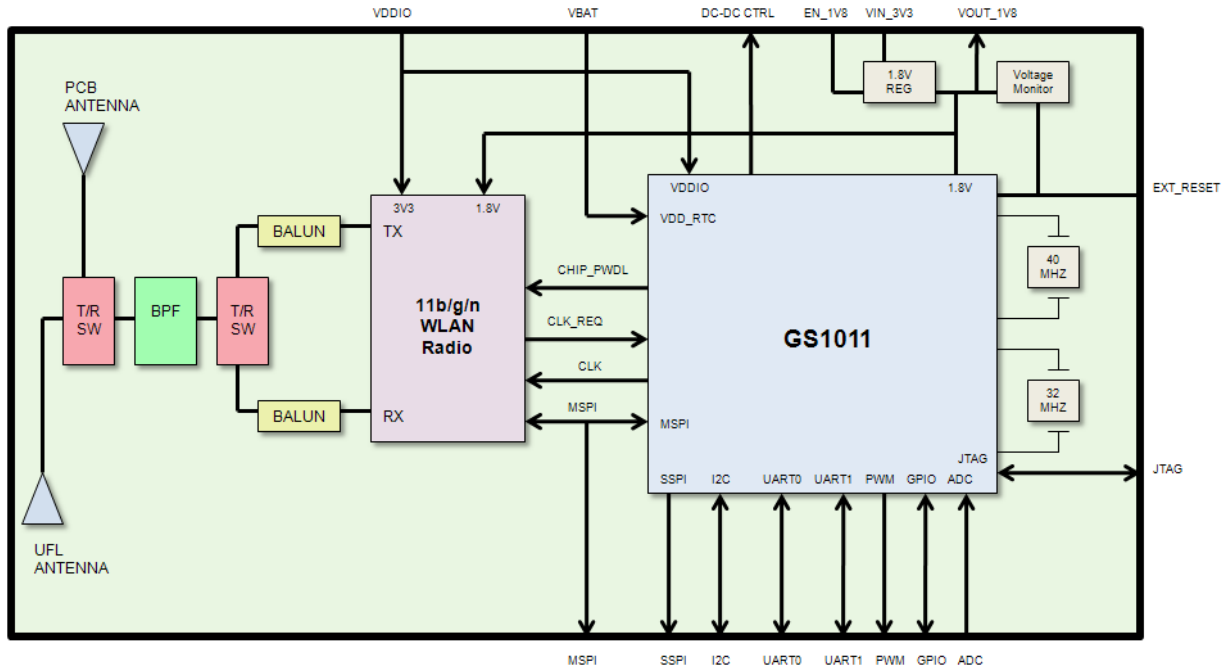

Figure 2-1: GS1500M Block Diagram

2.2 Block Diagram Description

2.2.1 Overview

GS1500M module is an integrated ultra low power Wi-Fi system-on-chip (SOC) that contains the following:

- The module includes:
 - a highly integrated IEEE 802.11b/g/n WLAN chip, which contains a MAC, baseband, security and radio functions in a single package
 - a GS1011 Chip, which contains two ARM7-based processors (one dedicated to Networking services, and the other dedicated to Wireless services), on-chip flash memory and SRAM in a single package
- The module carries an 802.11b/g/n radio with onboard 32 KHz & 44 MHz crystal circuitries, RF, and certified PCB antenna or external antenna options.
 - The module has a capability of +15dBm output power at the antenna (see Figure 2-1).
- Variety of interfaces are available such as two UART blocks using only two data lines per port with optional hardware flow controls, two SPI block (one dedicated as a serial slave with configurable hardware interrupt to the HOST), I²C with Master or slave operation, JTAG port,

low-power 10-bit ADC capable of running at up to 32 KSamples/sec., GPIO's, and LED Drivers/GPIO with 20mA capabilities.

- GS1500M contains single power supply (VIN_3V3) with optional module controlled external regulator enable control pin (DC_DC_CNTL), a separate I/O supply (VDDIO) that can be tied to the HOST supply rail without the use of external voltage translators, Real Time Clock (RTC) with battery supply monitor option (VBAT), and two external alarm inputs enable wake-up of the system on external events & outputs (ALARM and RTC_OUT) to enable periodic wake-up of the remainder of the system.
 - The Module carries onboard single supply monitor for under voltage supply and onboard 1.8V regulator with enable/disable capabilities for power critical applications.

2.2.2 Wireless LAN and System Control Subsystem

The GS1011 Wireless LAN and system control subsystem consists of an ARM7 TDMI-S CPU providing system control functions which provides for control and management functions of the external 802.11b/g/n WLAN chip.

2.2.3 Network Services Subsystem

2.2.3.1 APP CPU

The Network services subsystem consists of an APP CPU which is based on an ARM7 TDMI-S core. It incorporates an AHB interface and a JTAG debug interface. The network RTOS, network stack, and customer application code can reside on this CPU. For more information, consult the GS1011 Peripheral and Register Description [2] and GS1011 IC data sheet [3] for detailed descriptions.

2.2.4 Memory Subsystem

2.2.4.1 Overview

The GS1011 Chip contains several memory blocks:

- ▶ Boot ROM blocks.
 - ▶ The software contained in this ROM provides the capability to download new firmware via the SPI Slave or UART interfaces and to control the update of WLAN and APP Flash Memory.
- ▶ 384 Kbytes of Embedded Flash to store program code.
 - ▶ Three embedded Flash blocks of 128K bytes each
 - ▶ WLAN Flash (contains the wireless LAN and system control subsystem software)
 - ▶ APP Flash 0 and 1 (contain the Network/Application Software)
- ▶ 128 Kbytes of RAM shared between the two integrated CPU's.
- ▶ 512 bytes of RTC memory ((retains data in all states, as long as the battery or other voltage supply is present)

For more information, consult the GS1011 Peripheral and Register Description [2] and GS1011 IC data sheet [3] for detailed descriptions.

2.2.5 Clock Circuitries

The GS1500M architecture uses a low-power oscillator (i.e. 32 kHz) to provide a minimal subset of functions when the chip is in its low-power deep sleep mode, and a high-speed 44 MHz oscillator to provide clock signals for the processors, bus, and interfaces during active operation. Intermediate modes of operation, in which the 44 MHz oscillator is active but some modules are inactive, are obtained by gating the clock signal to different subsystems. The Clock & Reset Controller, within the device, is responsible for generation, selection and gating of the clocks used in the module to reduce power consumption in various power states.

2.2.5.1 Real Time Clock (RTC)

2.2.5.2 Overview

To provide global time (and date) to the system, the GS1500M Chip is equipped with a low-power Real Time Clock (RTC).

RTC key features include:

- ▶ 32.768 kHz crystal support.
- ▶ Two external alarm inputs to wake up the device.
- ▶ Two programmable periodic outputs (one for a DC/DC regulator and one for a sensor).
- ▶ Embedded 128x32 non-volatile (battery-powered) RAM.
- ▶ Embedded Power On Reset.
- ▶ Real Time Counter (48 bits; 46 bits effective).

An overview of RTC block diagram is shown in Figure 2-3. The RTC contains a low-power oscillator that can use 32.768 kHz crystals. In normal operation the RTC is always powered up, even in the Power Up state (see Figure 2-3).

Two programmable embedded alarm counters (wrap-around) are provided to enable periodic wake-up of the remainder of the system, and one independent external component (typically a sensor). Two external alarm inputs enable wake-up of the system on external events. The global times are recorded on each external event and if the system is in the Power-ON state (see Figure 2-8), an interrupt is provided. The RTC includes a Power-On Reset (POR) circuit, to eliminate the need for an external component. The RTC contains low-leakage non-volatile (battery-powered) RAM, to enable storage of data that needs to be preserved.

Total current consumption of the RTC in the worst case is typically less than 5 μ A without data storage, using the 32.768 kHz oscillator.

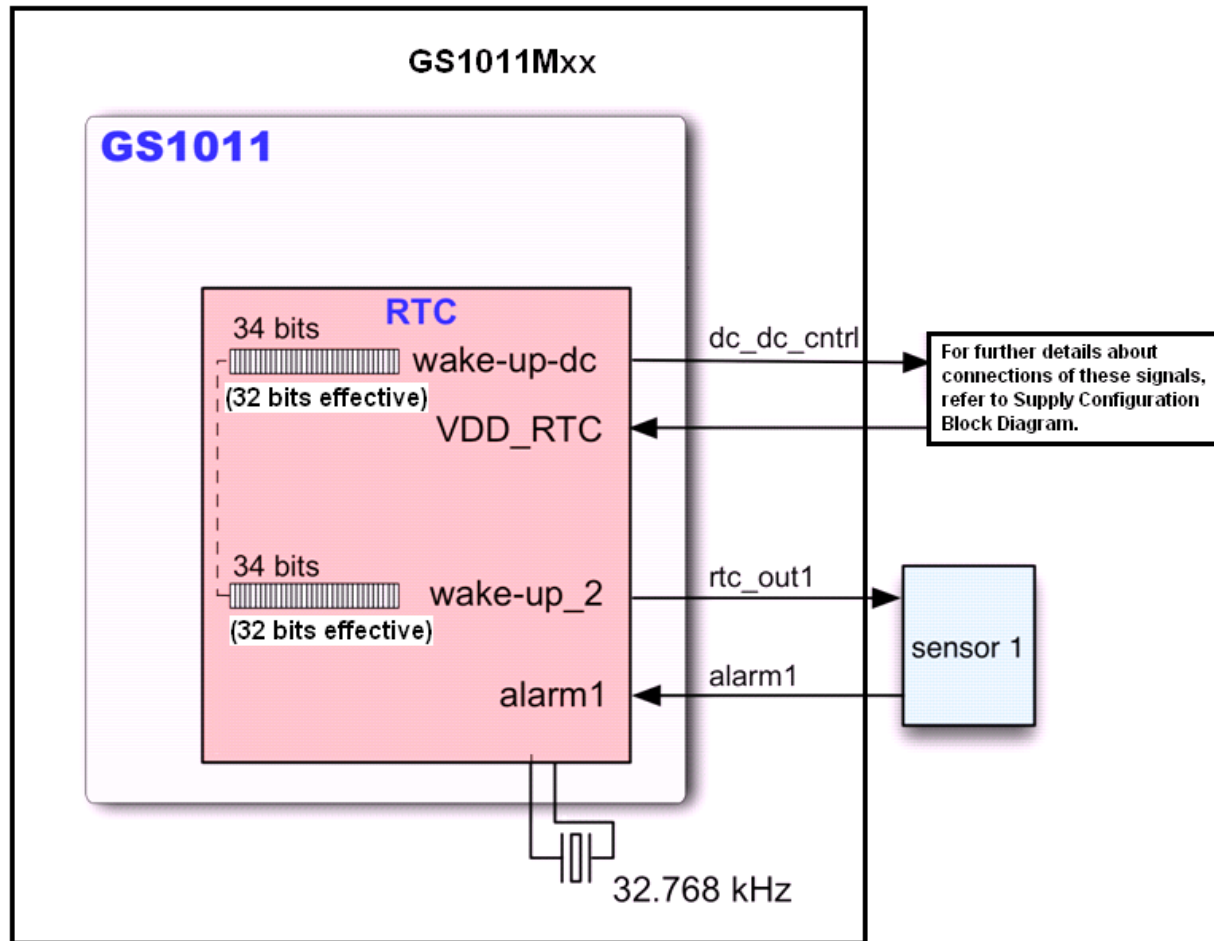

Figure 2-2: RTC Interface Diagram

Resolution of the wake-up timer is one clock cycle, and, with onboard 32KHz. CLK, each 32bit effective register can provide up to 1.5 days worth of standby duration as the longest standby period. Polarity of the rtc_out1 pin is programmable.

2.2.5.3 Real Time Counter

The Real Time Counter features:

- ▶ 48-bit length (with absolute duration dependent on the crystal frequency used).
- ▶ Low-power design.

This counter is automatically reset by power-on-reset.

This counter wraps around (returns to “all-0” once it has reached the highest possible “all-1” value).

2.2.5.4 RTC Outputs

There are two RTC outputs (dc_dc_cntrl and rtc_out1) that can be used to control external devices, such as sensors or voltage regulators. For more information, consult the GS1011 Peripheral and Register Description [2] and GS1011 IC data sheet [3] for detailed descriptions.

2.2.5.4.1 DC_DC_CNTL

During Power-on-Reset (e.g. when the battery is connected), the dc_dc_cntl pin is held low; it goes high to indicate completion of RTC power-on-reset. This pin can be used as an enable into an external device such as voltage regulator. For more information, consult the GS1011 Peripheral and Register Description [2] and GS1011 IC data sheet [3] for detailed descriptions.

2.2.5.4.2 RTC_OUT1

The rtc_out1 signal can be disabled or driven by the Wake-up Counter 2. This counter is 34 bits long, and operates in the same fashion as Wake-up Counter 1. The rtc_out1 signal can be configured to output the low-power crystal oscillator clock (i.e. the 32 kHz clock) instead of a simple state transition. Wake-up Counter 2 is automatically reset at Power-on-Reset. For more information, consult the GS1011 Peripheral and Register Description [2] and GS1011 IC data sheet [3] for detailed descriptions.

2.2.5.5 RTC Alarm Inputs 1 and 2

The RTC inputs alarm1 and alarm2 operate as follows:

- ▶ dc_dc_cntl is set to “1” (typically enabling the power supply to the rest of the GS1011) whenever either of these inputs changes state.
- ▶ The RTC counter value is stored each time either of these inputs changes state.

The inputs alarm1 and alarm2 have programmable polarity. Their task is to wake up the system (by setting dc_dc_cntl output pin to “1”) when an external event occurs. For more information, consult the GS1011 Peripheral and Register Description [2] and GS1011 IC data sheet [3] for detailed descriptions.

2.3 Peripherals

Note: For register identification and additional details on the use of shared peripherals, refer to the GS1011 Peripheral and Register Description [3].

2.3.1 SPI

There are two general-purpose SPI interfaces (each configurable as master or slave) for external sensors, memory, or external CPU interface; one interface may be configured as a high-speed Slave-only. The master SPI block provides dual synchronous serial communication interfaces. The Master SPI block can be used in one of two modes of operations: as a serial master or a serial slave. Each block provides synchronous serial communication with slave or master devices, using one of the following protocols:

- ▶ Motorola Serial Peripheral Interface (SPI).
- ▶ Texas Instruments Synchronous Serial Protocol (SSP).
- ▶ National Semiconductor Microwire Protocol.

Only Motorola Serial Peripheral Interface (SPI) timing is shown in this data sheet; however, National Semiconductor Microwire Protocol or Texas Instruments Synchronous Serial Protocol (SSP) modes are certainly supported. The SPI interface can also be used to access non-volatile external memory, such as an EEPROM block. The interface uses the SPI master mode to allow easy connection to industry-standard EEPROMs.

The shared SPI blocks provide the following general features:

- ▶ 32-bit AMBA APB interface to allow access to data, control, and status information by the host processor.
- ▶ Full-duplex serial-master or serial-slave operation.

- ▶ Two clock design:
 - APB bus clock for bus interface and registers.
 - Serial input clock for core logic.
- ▶ Support of external EEPROM or other non-volatile memory.
- ▶ Programmable choice of Motorola SPI, Texas Instruments Synchronous Serial Protocol or National Semiconductor Microwire.
- ▶ Programmable control of the serial bit rate of the data transfer in serial-master mode of operation.
- ▶ Programmable phase and polarity of the bit rate clock.
- ▶ Programmable transfer modes to perform transmit and receive, transmit only, receive only and EEPROM read transfers.
- ▶ Programmable data word size (8, 16, 24 & 32 bits) for each data transfer.
- ▶ Transmit and receive FIFO buffer depth 8 words (of the selected size).
- ▶ Configurable number of slave select outputs in serial-master mode of operation: 1 to 4 serial slave-select output signals can be generated.
- ▶ Combined interrupt line with independent masking of interrupts.
- ▶ Transmit FIFO overflow, transmit FIFO empty, transmit FIFO underflow, receive FIFO full, receive FIFO underflow, receive FIFO overflow, and receive FIFO timeout interrupts.
- ▶ Transmit FIFO empty and receive FIFO full interrupts provide programmable threshold values.

Both SPI blocks are configured to provide a FIFO depth of four entries.

The SPI master interface can be used to access external sensor devices, and EEPROM containing system parameters, under software control while the SPI slave interface can be used to provide control of the GS1500M from an external CPU.

SPI chip select (MPSISI_CS0 or MPSI_CS1) signals frame each data word. If the chip select is required to remain asserted for multiple data words, then a GPIO pin should be used for the chip select instead of the SPI chip select signals. For clock architecture and rates, please refer to section 7.1 Clock Architecture of GS1011 Peripheral and Register Description [2]. For other SPI Interface Timing, please refer to section 4.7.

2.3.2 I²C

The I²C block provides a two-wire I²C serial interface. It provides the following features:

- ▶ 32-bit AMBA APB interface to allow access to data, control, and status Information by the host processor.
- ▶ Serial 2-wire I²C bus, compliant to the I²C Bus Specification Version 2.1.
- ▶ Supports only one transfer in Standard mode (100 Kb/s) and fast speed mode with a bit rate of up to 392 Kb/s.
- ▶ Supports Multi-Master System Architecture through I²C bus SCL line Synchronization and Arbitration.
- ▶ Transmitter and Receiver: The I²C block can act as the Transmitter or Receiver depending on the operation being performed.
- ▶ Master or slave I²C operation.
- ▶ 7- or 10-bit addressing.

- ▶ Ignores CBUS addresses (an older ancestor of I²C that used to share the I²C bus).
- ▶ Interrupt or polled mode operation.
- ▶ Combined interrupt line triggered by:
 - Tx FIFO not FULL.
 - Rx FIFO not EMPTY.
 - Rx FIFO FULL (can be used to transfer data by host interface in bursts).
 - Tx FIFO EMPTY (can be used to transfer data by host interface in bursts).
 - Rx FIFO OVER RUN.
 - Master mode to Slave Transfer Request.
 - Slave Transmit Request.
 - Break Interrupt (master mode): No Acknowledge received from slave for slave address or write data.
- ▶ Digital debounce logic for the received SDA and SCL lines.
- ▶ Hold Delay Insertion on SDA line.

2.3.3 UART

The GS1500M includes two UART blocks. Each UART block provides an asynchronous communication interface, using only two data lines: Rx data and Tx data. Hardware flow control using RTS/CTS signaling is provided as an option. The UART is a standard asynchronous serial interface, 16450/16550 compatible. It provides the following features:

- ▶ Operation in full-duplex mode.
- ▶ All standard bit rates up to 921.6 kbps are supported.
- ▶ RTS/CTS flow control handshake (standard 16550 approach).
- ▶ 5, 6, 7 and 8-bit character format.
- ▶ 1 or 2 stop bits (1.5 in case of a 5-bit character format).
- ▶ Parity bit: none, even, odd, mark, or space.
- ▶ 16-byte Rx and 16-byte Tx FIFOs.

The UART Serial port can be used to communicate with a PC or other devices, for debug or additional functionality.

2.3.4 JTAG

The JTAG ports facilitate debugging of the board and system designs. This block has the following features:

- ▶ Compliant to IEEE-1149.1 TAP ports.
- ▶ One JTAG boundary scan TAP port.
- ▶ One set of JTAG pins, which support the following mode of operation:
 - APP ARM7TDMI-S Debug Mode.

A detailed example of JTAG debug access is described in GainSpan Application Note AN-011 [4].

2.3.5 GPIO & LED Driver / GPIO

The GPIO ports are referenced to VDDIO. Two GPIO pins called GPIO30_LED1 & GPIO31_LED2 have the capability to sink/source 20 mA typical (VDDIO=3.3V) to connect to devices such as switch contacts or LEDs. I2C_DATA/GPIO8 & I2C_CLK/GPIO9 have the capability to sink/source 12 mA typical (VDDIO=3.3V). Other GPIO's have the capability to sink/source 4 mA typical (VDDIO=3.3V). All inputs are capable of generating processor interrupts. They can be individually programmed to provide edge- or level-triggered interrupts. For details on configuring GPIO ports, refer to the GS1011 Peripheral and Register Description [2].

2.3.6 ADC

The ADC is a 10-bit, low-power, A-to-D converter capable of running at up to 32 ksp/s. The ADC contains an internal band-gap reference which provides a stable 1.2 V reference voltage. The ADC can be programmed to use the 1.8 V supply as the full-scale reference. The ADC uses an input clock with a maximum frequency of 1 MHz. A conversion requires 32 clock cycles.

When the internal band-gap reference is used, the reported integer *Value* at temperature T (°C) is related to the voltage V_{actual} at the input pin as:

$$V_{actual} = Value \left(\frac{1.2444 - 0.00014(25 - T)}{1023} \right)$$

When the 1.8V supply voltage is used as the reference, the corresponding relation is:

$$V_{actual} = Value \left(\frac{V_{DD,ADC} - 0.036}{1023} \right)$$

To reduce power consumption the ADC can be disabled automatically between periodic measurements and after single measurements.

For more information, consult the GS1011 Peripheral and Register Description [2] and GS1011 IC data sheet [3] for detailed descriptions.

2.4 System States

Figure 2-8 shows the power management/clock states of the GS1500M system.

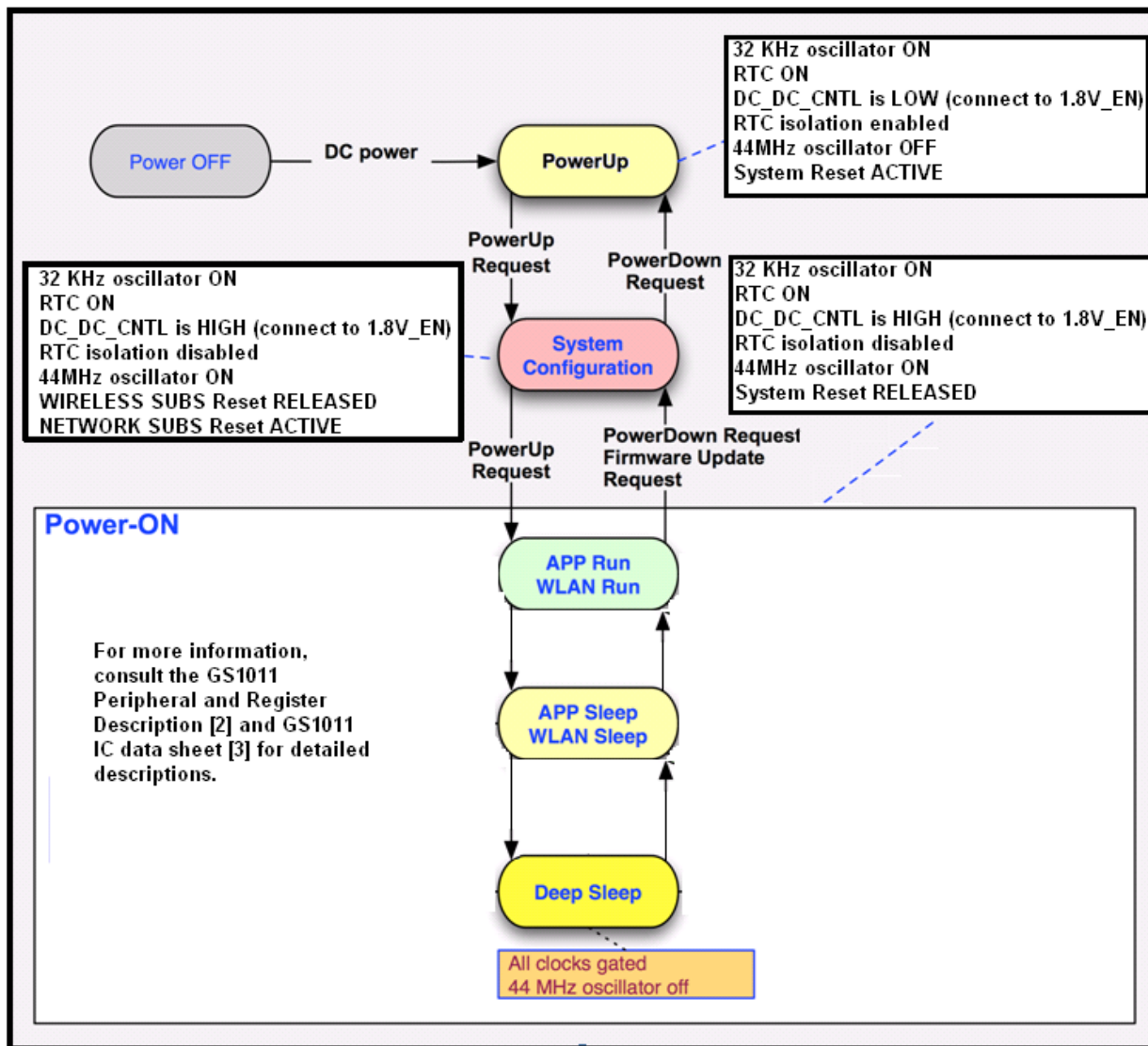

Figure 2-3: GS1500M System States

The system states of the GS1500M system are as follows:

Power OFF: No power source connected to the system.

Power Up: When supply voltage is stable and the RTC is powered up, and the system transitions from the Power OFF state to the Power Up state. In this state only the 32.768 kHz clock is running, and the RTC is powered directly by the battery or DC supply.

This is the lowest-power-consumption state.

Note: During first battery plug, i.e. when power is applied first time to the RTC power rail (VBAT), the RTC startup up latency will be at least couple of hundred ms as it is waiting for stabilization of the 32KHz crystal

System Configuration: When a power-up is requested, the system transitions from the Power Up state to the System Configuration state. In this state, the WLAN CPU is released from reset by the RTC. The APP CPU remains in the reset state during System Configuration. The WLAN CPU then executes the required system configurations, releases the APP CPU from reset, and transitions to the Power-ON state.

The System Configuration state is also entered on transition from the Power-ON state to the Power Up state, to complete necessary preparations before shutting off the power to the core system. Finally, the System Configuration state is used for firmware updates.

Power-ON: This is the active state where all system components can be running. The Power-ON state has various sub-states, in which unused parts of the system can be in sleep mode, reducing power consumption. Sleep states are implemented by gating the clock signal off for a specific system component. The Deep-Sleep sub-state, in which all clocks are gated off, allows minimum power consumption while permitting rapid resumption of normal operation. In this state, the 44 MHz reference oscillator can be turned off to further reduce power consumption.

For more information, consult the GS1011 Peripheral and Register Description [2] and GS1011 IC data sheet [3] for detailed descriptions.

3 Pin-out and Signal Description

3.1 GS1500M Device Pin-out Diagram (Module top view)

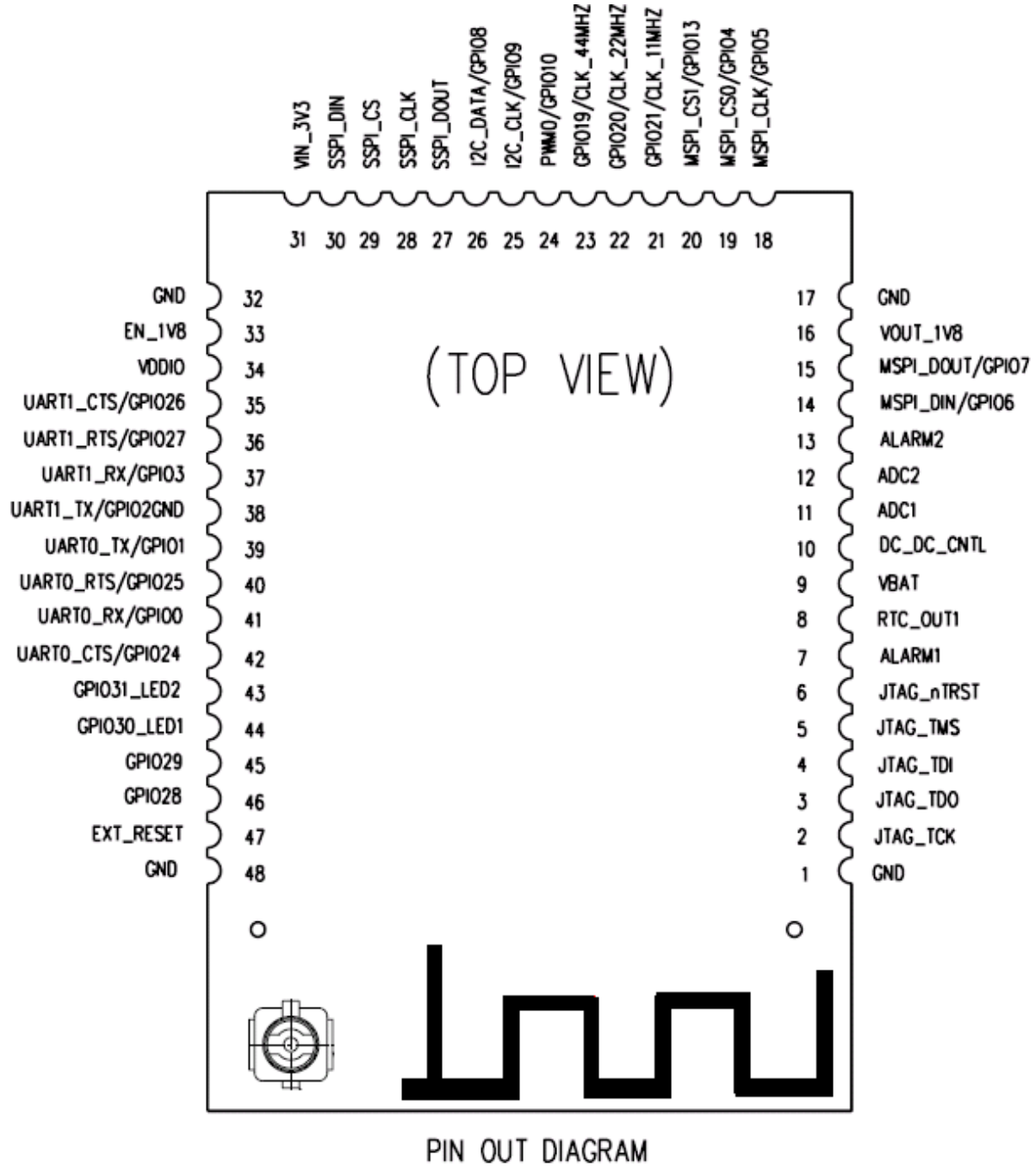

Figure 3-1: GS1500M Device Pin-out Diagram (Module top view)

3.1.1 GS1500M Module Pins Description

Pins	Name	Voltage Domain	Internal Bias after hardware reset	Signal State	Description
1	GND	0V	Not Applicable	Analog port	Ground
2	JTAG_TCK	VDDIO	Pull-up (See Note 1)	Digital Input	Joint Test Action Group Test Clock
3	JTAG_TDO	VDDIO	Not Applicable	Digital Output	Joint Test Action Group Test Data Out
4	JTAG_TDI	VDDIO	Pull-up (See Note 1)	Digital Input	Joint Test Action Group Test Data In
5	JTAG_TMS	VDDIO	Pull-up (See Note 1)	Digital Input	Joint Test Action Group Test Mode Select
6	JTAG_nTRST	VDDIO	Pull-up (See Note 1)	Digital Input	Joint Test Action Group Test Mode Reset Active Low
7	ALARM1	VBAT	Pull-down (See Note 1)	Digital Input	Embedded Real Time Clock Wake Up Input 1
8	RTC_OUT1	VBAT	Not Applicable	Digital Output	Embedded Real Time Clock Wake Up Output 1
9	VBAT	VBAT	Not Applicable	Analog port	Embedded Real Time Clock Power Supply
10	DC_DC_CNTL	VBAT	Not Applicable	Digital Output	VIN_3V3 Regulator Control Output
11	ADC1	VDD18 (internal)	Not Applicable	Analog Output	General Analog to Digital Converter 1
12	ADC2	VDD18 (internal)	Not Applicable	Analog Output	General Analog to Digital Converter 2
13	ALARM2	VBAT	Pull-down (See Note 1)	Digital Input	Embedded Real Time Clock Wake Up Input 2
14	MSPI_DIN / GPIO6	VDDIO	Pull-down	Digital Input	Master Serial Peripheral Interface Bus Data Input / General Purpose Input Output
15	MSPI_DOUT / GPIO7	VDDIO	Pull-down	Digital Output	Master Serial Peripheral Interface Bus Data Output / General Purpose Input Output
16	VOUT_1V8	VIN_3V3 (internally regulated)	Not Applicable	Analog port	Internal 1.8V Vout
17	GND	0V	Not Applicable	Analog port	Ground
18	MSPI_CLK / GPIO5	VDDIO	Pull-down	Digital Input / Output	Master Serial Peripheral Interface Bus Clock / General Purpose Input Output
19	MSPI_CS0 / GPIO4	VDDIO	Pull-down	Digital Input / Output	Master Serial Peripheral Interface Bus Chip Select 0 / General Purpose Input Output
20	MSPI_CS1 / GPIO13	VDDIO	Pull-down	Digital Output	Master Serial Peripheral Interface Bus Chip Select 1 / General Purpose Input Output
21	GPO21_11MHZ	VDDIO	Pull-down	Digital Input	Internal Clock Circuitry Test Point / General Purpose Input Output
22	GPO20_22MHZ	VDDIO	Pull-down	Digital Input	Internal Clock Circuitry Test Point / General Purpose Input Output

Pins	Name	Voltage Domain	Internal Bias after hardware reset	Signal State	Description
23	GPO19_44MHZ	VDDIO	Pull-down	Digital Input	Internal Clock Circuitry Test Point / General Purpose Input Output
24	PWM0 / GPIO10	VDDIO	Pull-down	Digital Output	Pulse Width Modulator / General Purpose Input Output
25	I2C_CLK/GPIO9	VDDIO	Pull-down (NOTE 4)	Digital Input / Output	Inter-Integrated Circuit Clock / General Purpose Input Output
26	I2C_DATA/GPIO8	VDDIO	Pull-down (NOTE 4)	Digital Input / Output	Inter-Integrated Circuit Data / General Purpose Input Output
27	SSPI_DOUT	VDDIO	Pull-up (See Note 1)	Digital Input	SPI Slave Transmit Data Output to the HOST
28	SSPI_CLK	VDDIO	Pull-up (See Note 1)	Digital Input	SPI Slave Clock Input from the HOST
29	SSPI_CS	VDDIO	Pull-up (See Note 1)	Digital Input	SPI Slave Chip Select Input from the HOST
30	SSPI_DIN	VDDIO	Pull-down (See Note 1)	Digital Input	SPI Slave Receive Data Input from the HOST
31	VIN_3V3	VIN_3V3	Not Applicable	Analog port	Single Supply Port
32	GND	0V	Not Applicable	Analog port	Ground
33	EN_1V8	VDDIO	Need to be driven HIGH or LOW externally	Digital Input	Internal 1.8V regulator enable port-Active High
34	VDDIO	VDDIO	Not Applicable	Analog port	All I/O voltage domain (can be tied to VIN_3V3 or tied to HOST I/O supply)
35	UART1_CTS / GPIO26	VDDIO	Pull-down	Digital Input	Universal Asynchronous Receiver Transmitter 1 Clear to Send Input / General Purpose Input Output
36	UART1_RTS / GPIO27	VDDIO	Pull-down (See Note 2)	Digital Output	Universal Asynchronous Receiver Transmitter 1 Request to Send Output / General Purpose Input Output
37	UART1_RX / GPIO3	VDDIO	Pull-down	Digital Input	Universal Asynchronous Receiver Transmitter 1 Receive Input / General Purpose Input Output
38	UART1_TX / GPIO2	VDDIO	Pull-down	Digital Output	Universal Asynchronous Receiver Transmitter 1 Transmitter Output / General Purpose Input Output
39	UART0_TX / GPIO1	VDDIO	Pull-down	Digital Output	Universal Asynchronous Receiver Transmitter 0 Transmitter Output / General Purpose Input Output
40	UART0_RTS / GPIO25	VDDIO	Pull-down	Digital Output	Universal Asynchronous Receiver Transmitter 0 Request to Send Output / General Purpose Input Output
41	UART0_RX / GPIO0	VDDIO	Pull-down	Digital Input	Universal Asynchronous Receiver Transmitter 0 Receive Input / General Purpose Input Output

Pins	Name	Voltage Domain	Internal Bias after hardware reset	Signal State	Description
42	UART0_CTS / GPIO24	VDDIO	Pull-down	Digital Input	Universal Asynchronous Receiver Transmitter 0 Clear to Send Input / General Purpose Input Output
43	GPO31_LED2	VDDIO	Pull-down	Digital Output	Light Emitting Diode Driver / General Purpose Input Output
44	GPIO30_LED1	VDDIO	Pull-down	Digital Output	Light Emitting Diode Driver / General Purpose Input Output
45	GPIO29	VDDIO	Pull-down (See Note 3)	Digital Input / Output	General Purpose Input Output
46	GPIO28	VDDIO	Pull-down (See Note 3)	Digital Input / Output	General Purpose Input Output
47	EXT_RESET	VDDIO	Pull-up	Digital Input / Output	Module Hardware Reset Input and Power Supply Reset Monitor Indicator
48	GND	0V	Not Applicable	Analog port	Ground

Table 3-1: Signal Description

Notes:

1. These pins have onboard hardware configured pull-ups/downs and cannot be changed by software.
2. If UART1_RTS is high during boot, then the WLAN will wait for Flash download via UART0. For development purposes, route this pin to a test point on the board so it can be pulled up to VIN_3V3.
3. GPIO 28 and 29 are sampled at reset to establish JTAG configuration for debugging. These signals should not be driven from an external device. If using JTAG, configure these pins as outputs.
4. If I²C interface is used, provide 2K Ohm pull-ups, to VDDIO, for pins 25 and 26 (I2C_CLK and I2C_DATA)

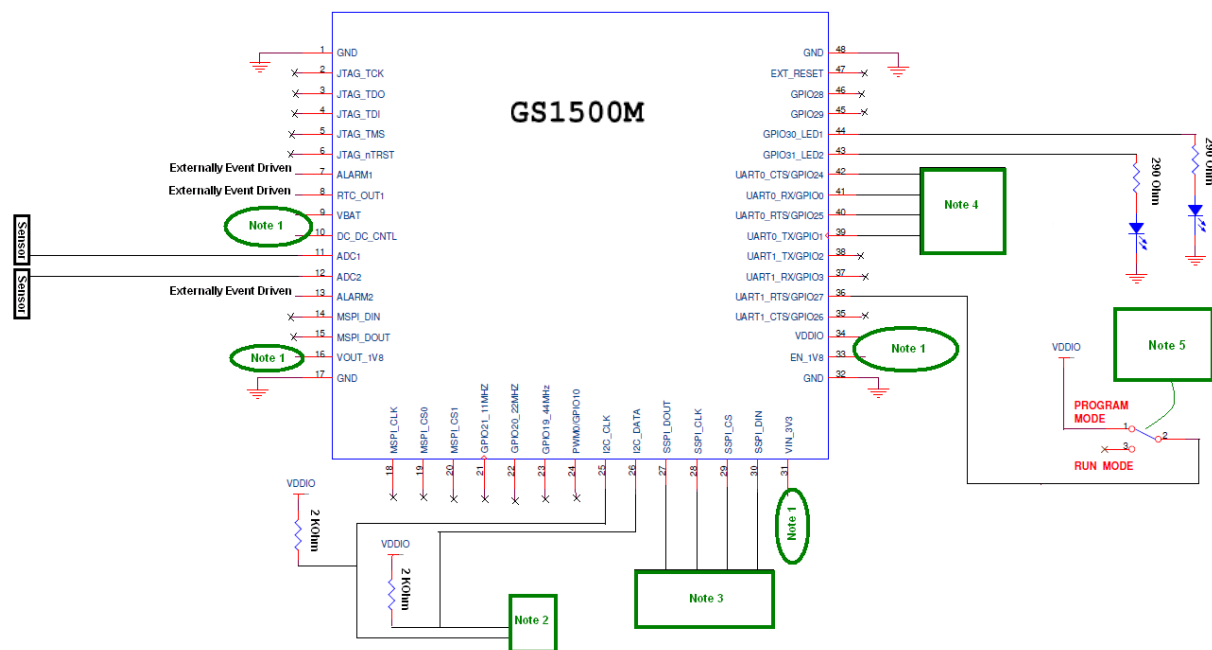

Figure 3-2: Module pin connection diagram

- Note 1) For the noted pin configurations, please refer to data sheet power supply section.
- Note 2) If I²C interface is used, provide 2KOhm pull-ups, to VDDIO, for pins 25 and 26 (I2C_CLK and I2C_DATA). If not used, leave pins 25 and 26 as No Connects.
- Note 3) Connect to external HOST SPI (can be left as No Connects if not used).
- Note 4) Connect to external serial HOST UART (can be left as No Connections if not used)
- Note 5) This switch enables the programming of GS1011 onboard flash. Switch is recommended for development purposes and is not needed for production.

4 Electrical Characteristics

4.1 Absolute Maximum Ratings

Conditions beyond those cited in Table 4-1 may cause permanent damage to the GS1500M, and must be avoided.

Parameter	Symbol	Minimum	Typical	Maximum	Unit
Storage temperature	T _{ST}	-55		+125	°C
RTC Power Supply	Vbat	-0.5		4.0	V
I/O Supply voltage	VDDIO	-0.5		4.0	V
Single Supply Port	VIN_3V3	2.7	3.3	4.0	V

Table 4-1: Absolute Maximum Ratings

NOTE: For limitations on state voltage ranges, please consult section 2.6.1 Power supply.

4.2 Operating Conditions

Parameter	Symbol	Minimum	Typical	Maximum	Unit
Extended temp. range	T _A	-40		+85	°C
RTC Power Supply	Vbat	2.5	3.3	3.6	V
I/O Supply voltage	VDDIO	1.7	3.3	3.6	V
Single Supply Port GS1500M	VIN_3V3	2.7	3.3	3.6	V

Table 4-2: Operating Conditions

4.3 Internal 1.8V regulator

VIN_3V3=VDDIO=Vbat=3.3V Temp=25°C fOSC=3.0MHz

Parameter	Symbol	Test conditions	Minimum	Typical	Maximum	Unit
Output Voltage	VOUT_1V8			1.8		V
Maximum Output Current	I _{VOUT_1V8}			30	50	mA
Oscillation Frequency	fOSC		1.6		3.45	MHz
1.8V Regulator Enable "H" Voltage	EN_1V8		1.0		VIN_3V3	V
1.8V Regulator Enable "L" Voltage	EN_1V8		0		0.25	V

Table 4-3: Internal 1.8V Regulator

4.4 I/O DC Specifications

4.4.1 Digital Input Specifications

Parameter	Symbol	Minimum	Typical	Maximum	Unit	Note
Input Low Voltage	V_{IL}	-0.3		0.25* VDDIO	V	
Input High Voltage	V_{IH}	0.8* VDDIO		VDDIO	V	

Table 4-4: Digital Input Parameters

4.4.2 Digital Output Specification

Parameter	Symbol	Minimum	Typical	Maximum	Unit	Note
Output Low Voltage	V_{OL}	0		0.4	V	With 4 mA load
Output High Voltage	V_{OH}	1.3 V		VDDIO	V	$V_{DDIO}=3.0V$, DC current load 4.0 mA $V_{DDIO}=1.62V$, DC current load 2.0 mA
Output rise time @ VDDIO=3.3V	t_{TLH}			7	ns	With 4 mA, 33 pF load
Output fall time @ VDDIO=3.3V	t_{THL}			7	ns	With 4 mA, 33 pF load

Table 4-5: Digital Output Parameters

4.4.3 I/O Digital Specifications (Tri-State)

Parameter	Symbol	Minimum	Typical	Maximum	Unit	Note
Input Low Voltage	V_{IL}	-0.3		0.25* VDDIO	V	
Input High Voltage	V_{IH}	0.8* VDDIO		VDDIO	V	
Schmitt trig. Low to High threshold point	V_{T+}	1.5			V	
Schmitt trig. High to Low threshold point	V_{T-}			1	V	
Input Leakage Current	I_L			5	μA	Pull up/down disabled
Tri-State Output Leakage Current	O_{ZL}			5	μA	Pull up/down disabled
Pull-Up Resistor	R_u	0.05		1	$M\Omega$	
Pull-Down Resistor	R_d	0.05		1	$M\Omega$	

Parameter	Symbol	Minimum	Typical	Maximum	Unit	Note
Output Low Voltage	V_{OL}	0		0.4	V	With 4/12/20 mA load
Output High Voltage	V_{OH}	1.3 V		VDDIO	V	With 4/12/20 mA load With 2/6/10 mA load
Output rise time @ VDDIO = 3.3V	t_{ToLH}			7	ns	With 4/12/20 mA load, 33 pF
Output fall time @ VDDIO = 3.3V	t_{ToHL}			7	ns	With 4/12/20 mA load, 33 pF
Input rise time	t_{TiLH}			7	ns	
Input fall time	t_{TiHL}			7	ns	

Table 4-6: I/O Digital Parameters

4.4.4 RTC Input Specifications (with Schmitt Trigger)

Parameter	Symbol	Minimum	Typical	Maximum	Unit	Note
I/O Supply Voltage	V_{DDRTC}	1.2		Vbat	V	
Input Low Voltage	V_{IL}	-0.3		$0.25 \cdot V_{DDRTC}$	V	
Input High Voltage	V_{IH}	$0.8 \cdot V_{DDRTC}$		V_{DDRTC}	V	
Schmitt trig. Low to High threshold point	V_{T+}	$0.57 \cdot V_{DDRTC}$		$0.68 \cdot V_{DDRTC}$	V	
Schmitt trig. High to Low threshold point	V_{T-}	$0.27 \cdot V_{DDRTC}$		$0.35 \cdot V_{DDRTC}$	V	
Input Leakage Current	I_L		260		pA	

Table 4-7: RTC Input Parameters

4.4.5 RTC Output Specifications

Parameter	Symbol	Minimum	Typical	Maximum	Unit	Note
I/O Supply Voltage	V_{DDRTC}	1.2		Vbat	V	
Output Low Voltage	V_{OL}	0		0.4	V	
Output High Voltage	V_{OH}	$0.8 \cdot V_{DDRTC}$		V_{DDRTC}	V	
Output rise time	t_{TLH}	19		142	ns	50 pF load
Output fall time	t_{THL}	21		195	ns	50 pF load
Input Leakage Current	I_L		730		pA	

Table 4-8: RTC Output Parameters

4.5 Power Consumption (estimated)

Test Conditions: VDD33=VDDIO=Vbat=3.3V Temp=25°C

System state	Current (Typ.)
Deep Sleep	3mA
Receive (GS1500M; -xx dBm RX sens. @ xxMbps.	TBD
Transmit (GS1500M; xx dBm at antenna port @ 11n HT20 MCS7)	TBD

Table 4-9: Power Consumption in Different States

4.6 Radio Parameters

Test Conditions: VIN_3V3=VDDIO=Vbat=3.3V Temp=25°C

Parameter	Minimum	Typical	Maximum	Unit	Notes
RF Frequency range	2412		2497	MHz	
Radio bit rate	1		HT20 MCS7	Mbps	
Transmit/Receive specification for GS1500M					
Output power (average)		11		dBm	Modulated signal at antenna port; 54 Mbps.
Spectrum Mask				dBr	Modulated signal at antenna port
F0 +/- 11 MHz Offset >= 22 MHz	-TBD -TBD				
Receive Sensitivity at antenna port		-TBD -73 -94		dBm	HT20, MCS7 OFDM, 8% PER 54 Mbps OFDM, 8% PER 1 Mbps BPSK, 8% PER

Table 4-10: Radio Parameters

4.7 ADC Parameters

Test Conditions: VIN_3V3=VDDIO=Vbat=3.3V Temp=25°C

Parameter	Minimum	Typical	Maximum	Unit	Notes
ADC Resolution	-	10	-	Bits	
ADC Sample Freq	1.024	-	31.25	ksps	
ADC input Clock Freq	32.768	-	1000	kHz	
ADC Full Scale Voltage		VOUT_1V8 – 0.036		V	Reference = VOUT_1V8
Conversion Time		32		Clocks	Based on internally generated 1MHz or 32.768 KHz Clocks
ADC Integral Non-Linearity (INL)	-2.0	-	2.0	LSB	
ADC Differential non-linearity (DNL)	-1.0	-	1.0	LSB	
AVDD Power Supply current (operational)	-	400	800	μA	
ADC Offset Error	-10	-	10	mV	
ADC Gain Error	-10	-	10	mV	
Settling Time		-	1	μS	
Input resistance	1	-	-	MOhm	
Input Capacitance	-	10	-	pF	
Bandgap Output Voltage (Vref) (T = 25 °C)	1.179	1.24	1.301	V	

Table 4-11: ADC Parameters

4.8 SPI Interface Timing

Test Conditions: VIN_3V3=VDDIO=Vbat=3.3V Temp=25°C

4.8.1 Motorola SPI, clock polarity SPO = 0, clock phase SPH = 0

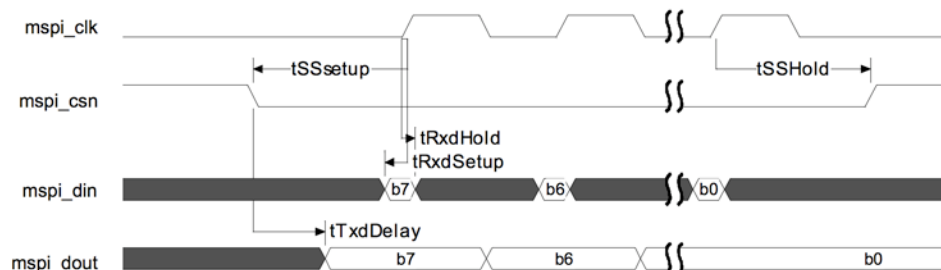

Figure 4-1: timing diagram, Master mode, SPO=SPH=0.

Parameter	Description	Minimum	Maximum	Unit
tSSsetup	Minimum time between falling edge of Select line and first rising edge of SPI clock	1		MSPI clock period
tTxdDelay	Delay in Master asserting TX line after falling edge of Select line		2 core SPI clock periods + 3 nsec	mixed
tRxdSetup	Time before rising edge of SPI clock by which received data must be ready	30		nsec
tRxdHold	Time for which received data must be stable after rising edge of SPI clock	10		nsec
tSSHold	Time for which the Select line will be held after the sampling edge for the final bit to be transferred	1		MSPI clock period

Table 4-12: timing parameters, Master mode, SPO=SPH=0.

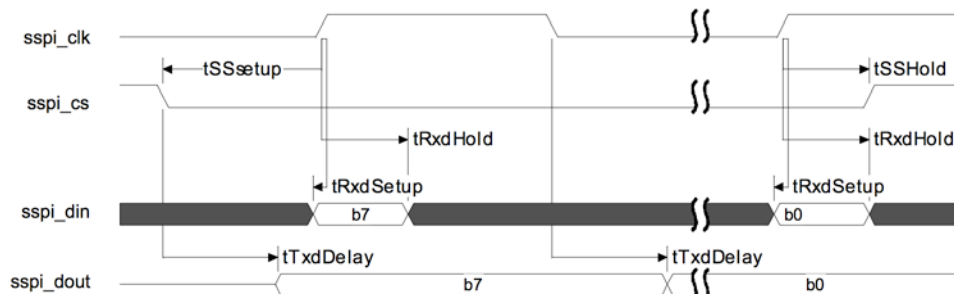

Figure 4-2: timing diagram, Slave mode, SPO=SPH=0.

Parameter	Description	Minimum	Maximum	Unit
tSSSetup	Minimum time between falling edge of Select line and first rising edge of SPI clock.	4 core SPI clock periods + 68 ns		mixed
tTxdDelay	Delay in Slave asserting TX line after falling edge of SPI clock, or the first bit after falling edge of the Select line.		4 core SPI clock periods + 68 ns	mixed
tRxdSetup	Time before rising edge of SPI clock by which received data must be ready	15		ns
tRxdHold	Time for which received data must be stable after rising edge of SPI clock	3 core SPI clock periods + 14 ns		mixed
tSSHold	Time for which the Select line will be held after the sampling edge for the final bit to be transferred	3 core SPI clock periods + 14 ns		mixed

Table 4-13: timing parameters, Slave mode, SPO=SPH=0.

4.8.2 Motorola SPI, clock polarity SPO = 0, clock phase SPH = 1

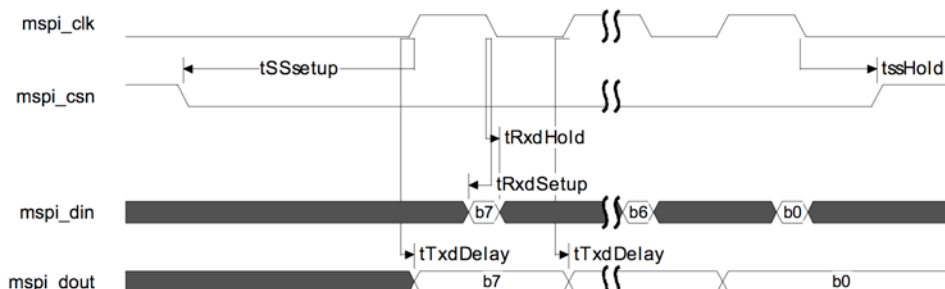

Figure 4-3: timing diagram, Master, SPO=0, SPH=1.

Parameter	Description	Minimum	Maximum	Unit
tSSSetup	Minimum time between falling edge of select line and first rising edge of SPI clock.	1.5		MSPI clock period
tTxdDelay	Delay in Master asserting TX line after rising edge of SPI clock.		0	ns
tRxdSetup	Time before falling edge of SPI clock by which received data must be ready.	30		ns
tRxdHold	Time for which received data must be stable after falling edge of SPI clock.	10		ns
tSSHold	Time for which the Select line will be held low after the sampling edge for the final bit to be transferred.	0.5		MSPI clock period

Table 4-14: timing parameters, Master mode; SPO=0, SPH=1.

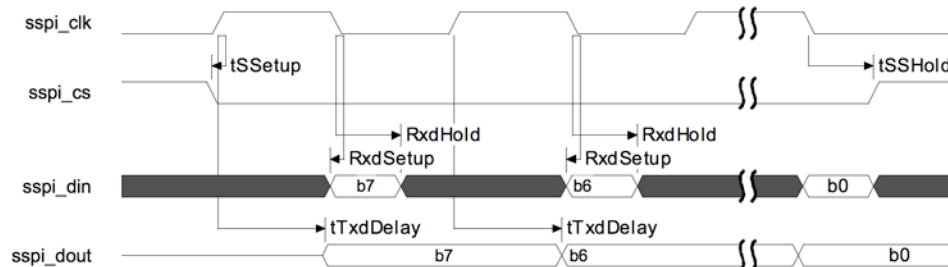

Figure 4-4: timing diagram, Slave, SPO=0, SPH=1.

Parameter	Description	Minimum	Maximum	Unit
tSSSetup	Minimum time between falling edge of select line and first rising edge of SPI clock.	15		ns
tTxdDelay	Delay in Slave asserting TX line after rising edge of SPI clock.		4 core SPI clock periods + 68 ns	mixed
tRxdSetup	Time before falling edge of SPI clock by which received data must be ready.	15		ns
tRxdHold	Time for which received data must be stable after falling edge of SPI clock.	3 core SPI clock periods + 14 ns		mixed
tSSHold	Time for which the Select line will be held low after the sampling edge for the final bit to be transferred.	3 core SPI clock periods + 14 ns		mixed

Table 4-15: timing parameters, Slave mode, SPO=0, SPH=1.

4.8.3 Motorola SPI, clock polarity SPO = 1, clock phase SPH = 0

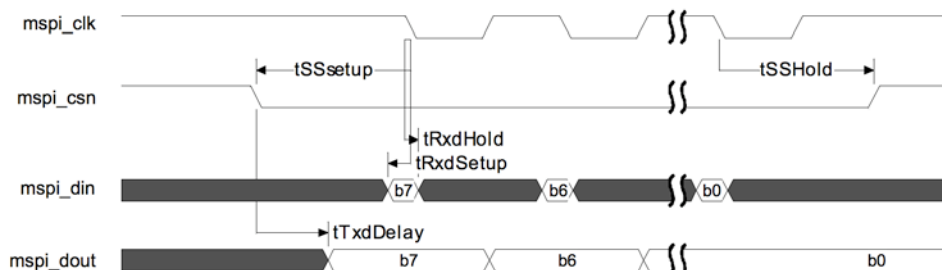

Figure 4-5: timing diagram, Master mode, SPO=1, SPH=0.

Parameter	Description	Minimum	Maximum	Unit
tSSetup	Minimum time between falling edge of select line and first falling edge of SPI clock.	1		MSPI clock period
tTxdDelay	Delay in Master asserting TX line after falling edge of Select line.		2 core SPI clock periods + 3 ns	mixed
tRxdSetup	Time before falling edge of SPI clock by which received data must be ready.	30		ns
tRxdHold	Time for which received data must be stable after falling edge of SPI clock.	10		ns
tSSHold	Time for which the Select line will be held low after the sampling edge for the final bit to be transferred.	1		MSPI clock period

Table 4-16: timing parameters, Master mode, SPO=1, SPH=0.

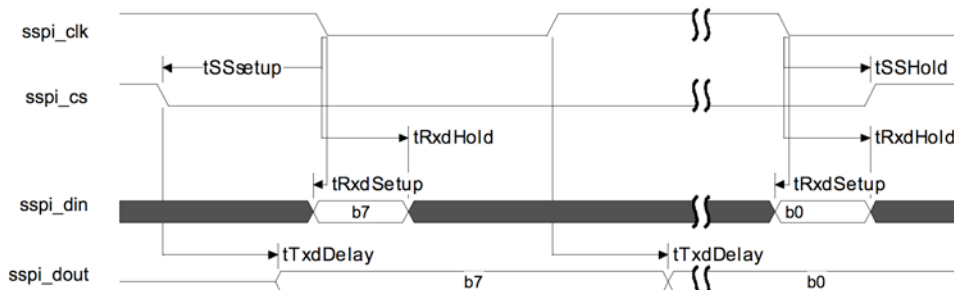

Figure 4-6: timing diagram, Slave mode, SPO=1, SPH=0.

Parameter	Description	Minimum	Maximum	Unit
tSSSetup	Minimum time between falling edge of Select line and first falling edge of SPI clock.	4 core SPI clock periods + 68 ns		Mixed
tTxdDelay	Delay in Slave asserting TX line after rising edge of SPI clock, or the first bit after falling edge of the Select line.		4 core SPI clock periods + 68 ns	Mixed
tRxdSetup	Time before falling edge of SPI clock by which received data must be ready.	15		ns
tRxdHold	Time for which received data must be stable after falling edge of SPI clock.	3 core SPI clock periods + 14 ns		Mixed
tSSHold	Time for which the Select line will be held low after the sampling edge for the final bit to be transferred.	3 core SPI clock periods + 14 ns		MSPI clock period

Table 4-17: timing parameters, Slave mode, SPO=1, SPH=0.

4.8.4 Motorola SPI, clock polarity SPO = 1, clock phase SPH = 1

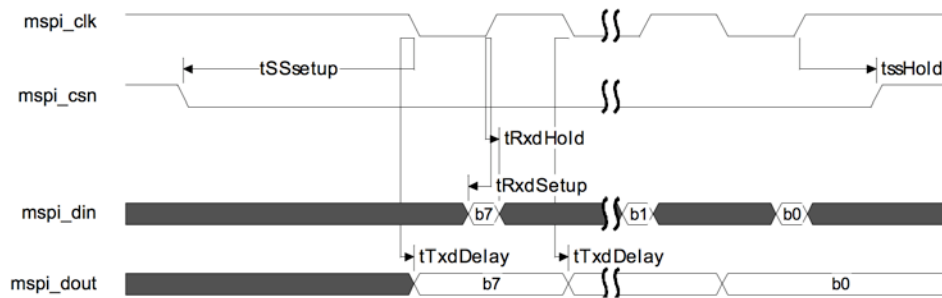

Figure 4-7: timing diagram, Master mode, SPO=SPH=1.

Parameter	Description	Minimum	Maximum	Unit
tSSSetup	Minimum time between falling edge of select line and first falling edge of SPI clock.	1.5		MSPI clock period
tTxdDelay	Delay in Master asserting TX line after falling edge of SPI clock.		0	ns
tRxdSetup	Time before rising edge of SPI clock by which received data must be ready.	30		ns
tRxdHold	Time for which received data must be stable after rising edge of SPI clock.	10		ns
tSSHold	Time for which the Select line will be held low after the sampling edge for the final bit to be transferred.	0.5		MSPI clock period

Table 4-18: timing parameters, Master mode, SPO=SPH=1.

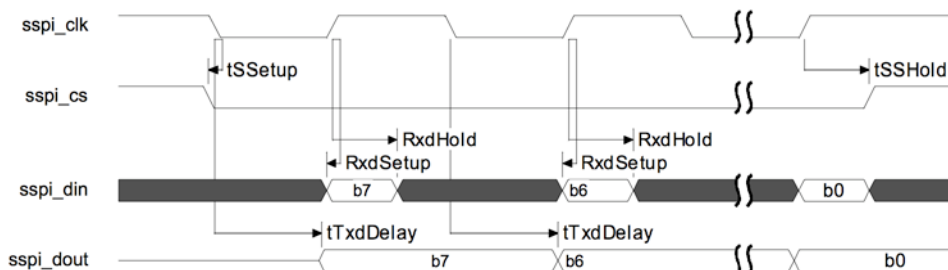

Figure 4-8: timing diagram, Slave mode, SPO=SPH=1.

Parameter	Description	Minimum	Maximum	Unit
tSSetup	Minimum time between falling edge of select line and first falling edge of SPI clock.	15		ns
tTxdDelay	Delay in Slave asserting TX line after falling edge of SPI clock.		4 core SPI clock periods + 68 ns	Mixed
tRxdSetup	Time before rising edge of SPI clock by which received data must be ready.	15		ns
tRxdHold	Time for which received data must be stable after rising edge of SPI clock.	3 core SPI clock periods + 14 ns		Mixed
tSSHold	Time for which the Select line will be held low after the sampling edge for the final bit to be transferred.	3 core SPI clock periods + 14 ns		Mixed

Table 4-19: timing parameters, Master mode, SPO=SPH=1.

4.9 Electrostatic discharge (ESD)

TBD

5 Package and Layout Guidelines

5.1 GS1500M Recommended PCB Footprint and Dimensions

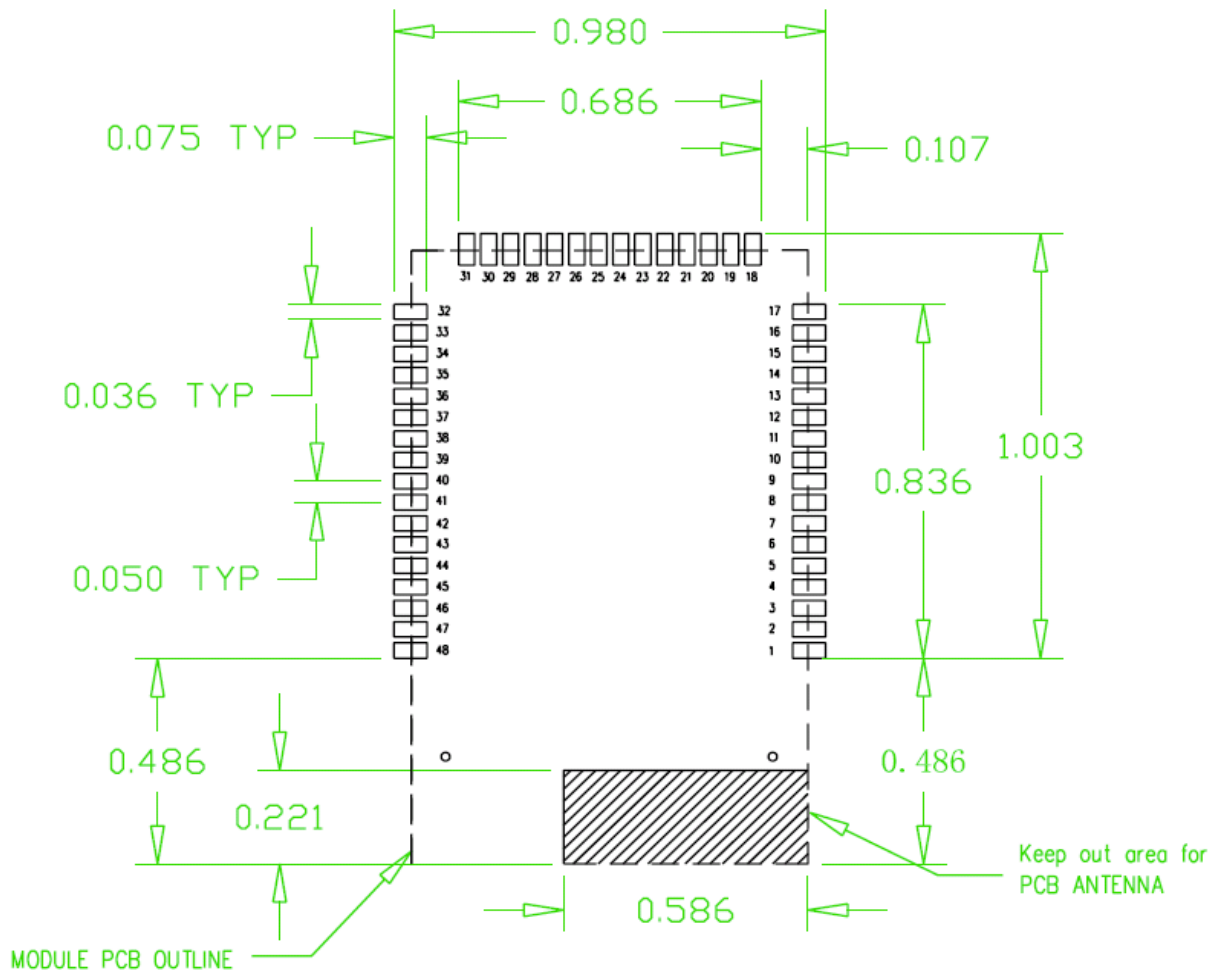

Figure 5-1: GS1500M Module Recommended PCB Footprint (dimensions are in inches)

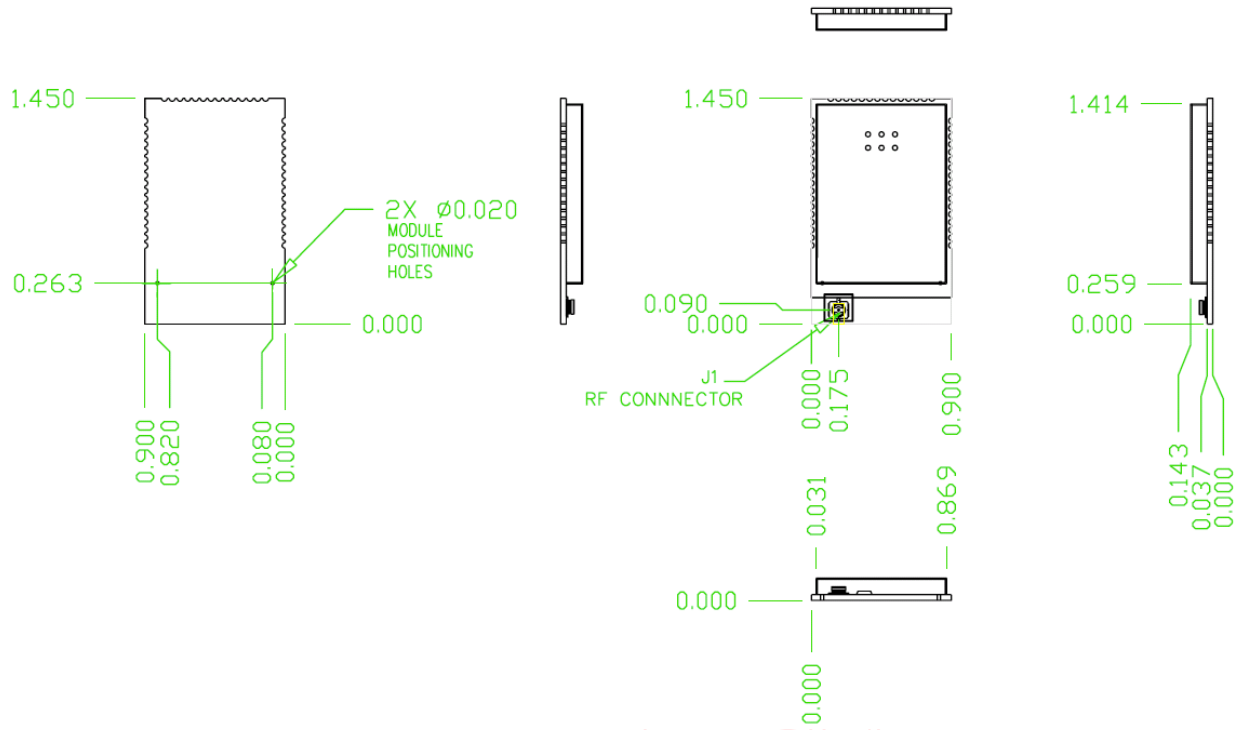

Figure 5-2: GS1500M Module Dimensions (in inches)

6 Ordering Information

DEVICE DESCRIPTION	ORDERING NUMBER	Rev
Low power module using PCB antenna	GS1500M	Rev X.X

7 Regulatory Notes

Federal Communication Commission Interference Statement

This equipment has been tested and found to comply with the limits for a Class B digital device, pursuant to Part 15 of the FCC Rules. These limits are designed to provide reasonable protection against harmful interference in a residential installation. This equipment generates uses and can radiate radio frequency energy and, if not installed and used in accordance with the instructions, may cause harmful interference to radio communications. However, there is no guarantee that interference will not occur in a particular installation. If this equipment does cause harmful interference to radio or television reception, which can be determined by turning the equipment off and on, the user is encouraged to try to correct the interference by one of the following measures:

- Reorient or relocate the receiving antenna.
- Increase the separation between the equipment and receiver.
- Connect the equipment into an outlet on a circuit different from that to which the receiver is connected.
- Consult the dealer or an experienced radio/TV technician for help.

FCC Caution: To assure continued compliance, (example - use only shielded interface cables when connecting to computer or peripheral devices). Any changes or modifications not expressly approved by the party responsible for compliance could void the user's authority to operate this equipment.

This device complies with Part 15 of the FCC Rules. Operation is subject to the following two conditions: (1) This device may not cause harmful interference, and (2) this device must accept any interference received, including interference that may cause undesired operation.

IMPORTANT NOTE:

FCC & IC Radiation Exposure Statement:

This equipment complies with FCC & IC radiation exposure limits set forth for an uncontrolled environment. This equipment should be installed and operated with minimum distance 20cm between the radiator & your body.

This transmitter must not be co-located or operating in conjunction with any other antenna or transmitter.

This device is intended only for OEM integrators under the following conditions:

- 1) The antenna must be installed such that 20 cm is maintained between the antenna and users, and
- 2) The transmitter module may not be co-located with any other transmitter or antenna.

As long as 2 conditions above are met, further transmitter test will not be required. However, the OEM integrator is still responsible for testing their end-product for any additional compliance requirements required with this module installed (for example, digital device emissions, PC peripheral requirements, etc.).

IMPORTANT NOTE: In the event that these conditions cannot be met (for example certain laptop configurations or co-location with another transmitter), then the FCC & IC authorizations are no longer considered valid and the FCC & IC IDs cannot be used on the final product. In these circumstances, the OEM integrator will be responsible for re-evaluating the end product (including the transmitter) and obtaining separate FCC & IC authorizations.

End Product Labeling

This transmitter module is authorized only for use in device where the antenna may be installed such that 20 cm may be maintained between the antenna and users (for example access points, routers, wireless ADSL modems, and similar equipment). The final end product must be labeled in a visible area with the corresponding FCC ID number.

IC Certification — Canada

The labeling requirements for Industry Canada are similar to those of the FCC. A visible label on the outside of the final product must display the IC labeling. The user is responsible for the end product to comply with IC ICES-003 (Unintentional radiators)

Manual Information That Must be Included

The user's manual for end users must include the following information in a prominent location.

IMPORTANT NOTE: To comply with FCC & IC RF exposure compliance requirements, the antenna used for this transmitter must be installed to provide a separation distance of at least 20 cm from all persons and must not be co-located or operating in conjunction with any other antenna or transmitter.

Other notes:

GainSpan modules have been built or under development for near body exposure applications.

The 20cm statement is a standard note because absorption rate testing (commonly known as SAR or Specific absorption rate) is not modularly transferable for FCC/IC. Thus, if a radio is being used against the body, the end user is still responsible to test for regulatory near body exposure testing (for USA, please refer to the following):

- FCC Part 1.1037
- FCC Part 2.1091 Mobile Devices
- FCC Part 2.1093 Portable Devices
- FCC Part 15.247 (b) (4)

8 Limitations

THIS DEVICE AND ASSOCIATED SOFTWARE ARE NOT DESIGNED, MANUFACTURED OR INTENDED FOR USE OR RESALE FOR THE OPERATION OF APPLICATION IN A HAZARDOUS ENVIRONMENT, OR REQUIRING FAIL-SAFE PERFORMANCE, OR IN WHICH THE FAILURE OF PRODUCTS COULD LEAD DIRECTLY TO DEATH, PERSONAL INJURY, OR SEVERE PHYSICAL OR ENVIRONMENTAL DAMAGE (COLLECTIVELY, "HIGH RISK APPLICATIONS"). YOU AGREE AND ACKNOWLEDGE THAT YOU HAVE NO LICENSE TO, AND SHALL NOT (AND SHALL NOT ALLOW A THIRD PARTY TO) USE THE TECHNOLOGY IN ANY HIGH RISK APPLICATIONS, AND LICENSOR SPECIFICALLY DISCLAIMS ANY WARRANTY REGARDING, AND ANY LIABILITY ARISING OUT OF, HIGH RISK APPLICATIONS.

9 References

[1]	Title	Wireless LAN Medium Access Control (MAC) and Physical Layer (PHY) Specifications		
	Reference	IEEE Standard 802.11-2007		
	Version		Date	June 12, 2007
	Source	IEEE		

[2]	Title	GS1011 Peripheral and Register Description		
	Reference	GS1011-PRD		
	Version	1.0	Date	November 11, 2009
	Source	GainSpan		

[3]	Title	GS1011 ULTRA LOW-POWER WIRELESS SYSTEM-ON-CHIP DATA SHEET		
	Reference	GS1011-DS		
	Version	1.0	Date	November 9, 2009
	Source	GainSpan		