

Model: D100N30AL-T4

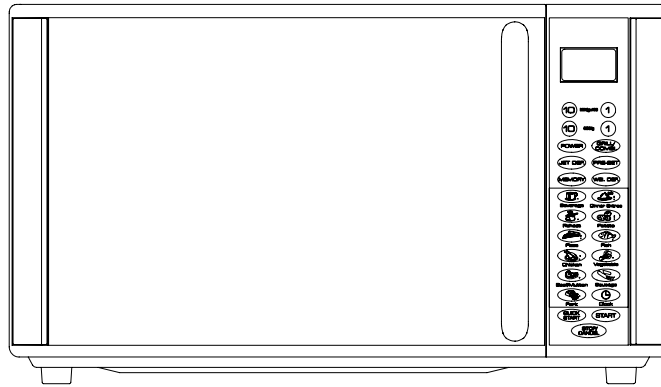

Microwave Oven

User's manual

Please read these instructions carefully before installing and operating the oven.

- Record in the space below the SERIAL NO. found on the nameplate on your oven and retain
1. this information for future reference.

SERIAL NO.

PRECAUTIONS TO AVOID POSSIBLE EXPOSURE TO EXCESSIVE MICROWAVE ENERGY

2. Do not attempt to operate this oven with the door-open since open-door operation can result in harmful exposure to microwave energy. It is important not to defeat or tamper with the safety interlocks.
3. Do not place any object between the oven front face and the door or allow soil or cleaner residue to accumulate on sealing surfaces.
4. Do not operate the oven if it is damaged. It is particularly important that the oven door close properly and that there is no damage to the:
 - a. Door (bent),
 - b. Hinges and latches (broken or loosened),
 - c. Door seals and sealing surfaces.
5. The oven should not be adjusted or repaired by anyone except properly qualified service personnel.

CONTENT

PRECAUTIONS TO AVOID POSSIBLE EXPOSURE TO EXCESSIVE MICROWAVE ENERGY	1
IMPORTANT SAFETY INSTRUCTIONS.....	2
INSTALLATION GUIDE.....	3
GROUNDING INSTRUCTIONS.....	3
UTENSILS GUIDE	4
COOKING TECHNIQUES.....	5
SPECIFICATIONS.....	6
PART NAMES	6
CONTROL PANEL	7
HOW TO SET THE OVEN CONTROLS	8
Setting the clock.....	8
Microwave cooking.....	8
Grill cooking.....	8
Combination cooking.....	8
Auto Cook.....	9
Defrost by weight.....	9
Jet Defrost.....	9
Multi-stage Cooking.....	10
Delay start	10
Quick start	10
Child Lock.....	10
Special Feature	10
CLEANING AND CARE.....	11

IMPORTANT SAFETY INSTRUCTIONS

When using electrical appliances, basic safety precautions should be followed, including the following:

WARNING - To reduce the risk of burns, electric shock, fire, injury to persons or exposure to excessive microwave energy:

1. Read all instructions before using the appliance.
2. Read and follow the specific "PRECAUTIONS TO AVOID POSSIBLE EXPOSURE TO EXCESSIVE MICROWAVE ENERGY" on page 1.
3. This appliance must be grounded. Connect only to properly grounded outlet. See "grounding instructions " on page 3.
4. Install or locate this appliance only in accordance with the provided installation instructions.
5. Some products such as whole eggs and sealed containers -for example, closed glass jars- are able to explode and should not be heated in this oven.
6. Use this appliance only for its intended use as described in this manual. Do not use corrosive chemicals or vapors in this appliance. This type of oven is specifically designed to heat, cook, or dry food. It is not designed for industrial or laboratory use.
7. As with any appliance, close supervision is necessary when used by children.
8. To reduce the risk of fire in the oven cavity:
 - a. Do not overcook food. Carefully attend appliance when paper, plastic, or other combustible materials are placed inside the oven to facilitate cooking.
 - b. Remove wire twist-ties from paper or plastic bags before placing bag in oven.
 - c. If materials inside the oven should ignite, keep oven door closed, turn oven off, and disconnect the power cord or shut off power at the fuse or circuit breaker panel.
 - d. Do not use the cavity for storage purposes. Do not leave paper products, cooking utensils or food in the cavity when not in use.
9. Liquids, such as water, coffee, or tea are able to be overheated beyond the boiling point without appearing to be boiling due to surface tension of the liquid. Visible bubbling or boiling when the container is removed from the microwave oven is not always present. **THEIS COULD RESULT IN VERY HOT LIQUIDS SUDDENLY BOILING OVER WHEN A SPOON OR OTHER UTENSIL IS INSERTED INTO THE LIQUID.** To reduce the risk of injury to person:
 - a. Do not overheat the liquid.
 - b. Stir the liquid both before and halfway through heating it.
 - c. Do not use straight-sided containers with narrow necks.
 - d. After heating, allow the container to stand in the microwave oven for a short time before removing the container.
 - e. Use extreme care when inserting a spoon or other utensil into the container.
10. Do not heat oil or fat for deep-frying. It is difficult to control the temperature of oil in microwave oven.
11. Pierce foods with heavy skins such as potatoes, whole squash, apples and chestnuts before cooking.
12. The contents of feeding bottles and baby jars should be stirred or shaken and the temperature should be checked before serving in order to avoid burns.
13. Cooking utensils may become hot because of heat transferred from the heated food. Potholders may be needed to handle the utensil.
14. Do not cover or block any openings on the appliance.
15. Do not store or use this appliance outdoors. Do not use this product near water, for example, near a kitchen sink, in a wet basement, near a swimming pool, or similar locations.
16. Do not operate this appliance if it has a damaged cord or a plug, if it is not working properly or if it has been damaged or dropped.
17. Do not immerse cord or plug in water. Keep cord away from heated surface. Do not let cord hang over edge of table or counter.

SAVE THESE INSTRUCTIONS

18. Use only thermometers, which are specifically designed for use in microwave ovens.
19. Do not operate any heating or cooking appliance beneath this appliance.
20. Be certain the glass tray and roller rings are in place when you operate the oven.
21. This appliance should be serviced only by

qualified service personnel, contact nearest authorized service facility for examination, repair, or adjustment.

22. When cleaning surfaces of door and oven that comes together on closing the door, use only mild, nonabrasive soaps, or detergents applied with a sponge or soft cloth

INSTALLATION GUIDE

- | | |
|---|---|
| <ol style="list-style-type: none"> 1. Make sure that all the packing materials are removed from the inside of the door. 2. Check the oven for any damage, such as misaligned or bent door, damaged door seals and sealing surface, broken or loose door hinges and latches and dents inside the cavity or on the door. If there is any damage, do not operate the oven but contact qualified service personnel. 3. This microwave oven must be placed on a flat, stable surface to hold its weight and the heaviest food likely to be cooked in the oven. 4. Do not place the oven where heat, moisture, or high humidity are generated, or near combustible materials. | <ol style="list-style-type: none"> 5. For correct operation, the oven must have sufficient airflow. Allow 20cm of space above the oven, 10cm at back and 5cm at both sides. Do not cover or block any openings on the appliance. Do not remove feet on which oven stands. 6. Do not operate the oven without glass tray, roller support, and shaft in their proper positions. 7. Make sure that the power supply cord is undamaged and does not run under the oven or over any hot or sharp surface. 8. The socket must be readily accessible so that it can be easily unplugged in an emergency. |
|---|---|

GROUNDING INSTRUCTIONS

This appliance must be grounded. In the event of an electrical short circuit, grounding reduces risk of electric shock by providing an escape wire for the electric current.

WARNING Improper use of the grounding plug can result in a risk of electric shock.

ELECTRICAL REQUIREMENTS

The electrical requirements are a 120 volt 60

Hz, AC only, 15 amp. It is recommended that a separate circuit serving only the oven be provided. The oven is equipped with a 3-prong grounding plug. It must be plugged into a wall receptacle that is properly installed and grounded.

Power Supply Cord

1. A short power supply cord is provided to reduce the risks resulting from becoming

SAVE THESE INSTRUCTIONS

entangled in or tripping over a longer cord.

2. Longer cord sets or extension cords are available and may be used if care is exercised in their use.

3. If long cord or extension cord is used:

a) The marked electrical rating of the cord set or extension cord should be at least as great as the electrical rating of the appliance.

b) The extension cord must be a grounding-type 3-wire cord, and The longer cord should be arranged so that it will not drape over the counter top or table top where it can be pulled on by children or tripped over

unintentionally.

Notes:

If you have any questions about the grounding or electrical instructions, consult a qualified electrician or service person.

Neither Galanz nor the dealer can accept any liability for damage to the oven or personal injury resulting from failure to observe the electrical connection procedures.

UTENSILS GUIDE

This section lists which utensils can be used in the microwave, which ones have limited use for short periods, and which ones should not be used in the microwave.



RECOMMENDED

Microwave browning dish — Use to brown the exterior of small items such as steaks, chops, or pancakes. Follow the directions provided with your browning dish.

Microwaveable plastic wrap — Use to retain steam. Leave a small opening for some steam to escape and avoid placing it directly on the food.

Paper towels and napkins — Use for short-term heating and covering; these absorb excess moisture and prevent spattering. Do not use recycled paper towels, which may contain metal and could ignite.

Glass and glass-ceramic bowls and dishes — Use for heating or cooking.

Paper plates and cups — Use for short-term heating at low temperatures. Do not use recycled paper, which may contain metal and

could ignite.

Wax paper — Use as a cover to prevent spattering.

Thermometers — Use only those labeled "Microwave Safe" and follow all directions. Check the food in several places. Conventional thermometers may be used on microwave food once the food has been removed from the oven.

LIMITED USE

Aluminum foil — Use narrow strips of foil to prevent overcooking of exposed areas. Using too much foil can damage your oven, so be careful. You should keep distance of 1 inch (2.54cm) between aluminum foil and cavity.

Ceramic, porcelain, and stoneware— Use these if they are labeled "Microwave Safe". If they are not labeled, test them to make sure they can be used safely.

Plastic — Use only if labeled "Microwave Safe". Other plastics can melt.

✘ Not Recommended

Glass jars and bottles — Regular glass is too thin to be used in a microwave. It can shatter and cause damage and injury.

Paper bags — These are a fire hazard, except for popcorn bags that are designed for microwave use.

Styrofoam plates and cups — These can melt and leave an unhealthy residue on food.

Plastic storage and food containers — Containers such as margarine tubs can melt in the microwave.

Metal utensils — These can damage your oven. Remove all metal before cooking.

Note:

Should you wish to check if a dish is safe for microwaving, place the empty dish in the oven and microwave on HIGH for 30 seconds. A dish which becomes very hot should not be used.

COOKING TECHNIQUES

Your microwave makes cooking easier than conventional cooking, provided you keep these considerations in mind:

STIRRING

Stir foods such as casseroles and vegetables while cooking to distribute heat evenly. Food at the outside of the dish absorbs more energy and heats more quickly, so stir from the outside to the center. The oven will turn off when you open the door to stir your food.

ARRANGEMENT

Arrange unevenly shaped foods, such as chicken pieces or chops, with the thicker, meatier parts toward the outside of the turntable where they receive more microwave energy. To prevent overcooking, place delicate areas, such as asparagus tips, toward the center of the turntable.

SHIELDING

Shield food with narrow strips of aluminum foil to prevent overcooking. Areas that need

shielding include poultry wing tips, the ends of poultry legs, and corners of square baking dishes. Use only small amounts of aluminum foil. Larger amounts can damage your oven.

TURNING

Turn foods over midway through cooking to expose all parts to microwave energy. This is especially important with large foods such as roasts.

STANDING

Foods cooked in the microwave build up internal heat and continue to cook for a few minutes after heating stops. Let foods stand to complete cooking, especially foods such as cakes and whole vegetables. Roasts need this time to complete cooking in the center without overcooking the outer areas. All liquids, such as soup or hot chocolate, should be shaken or stirred when cooking is complete. Let liquids stand a moment before serving. When heating baby food, stir well at removal and test the temperature before serving.

content should be covered or allowed to stand so that the heat disperses evenly. Add a small amount of water to dry food to help it cook.

ADDING MOISTURE

Microwave energy is attracted to water molecules. Food that is uneven in moisture

SPECIFICATIONS

Power Consumption:	120V~60Hz, 1500W (MICROWAVE)
Output:	1000W
Operation Frequency:	2450MHz
Outside Dimensions(H×W×D):	11.9×19.8×15.8 in.
Oven Cavity Dimensions(H×W×D):	8.4×13.7×12.9 in.
Oven Capacity:	0.9cu.ft
Cooking Uniformity:	Turntable System (Φ12")
Net Weight:	Approx. 34.4lb.

Note: The above data must be confirmed or updated.

PART NAMES

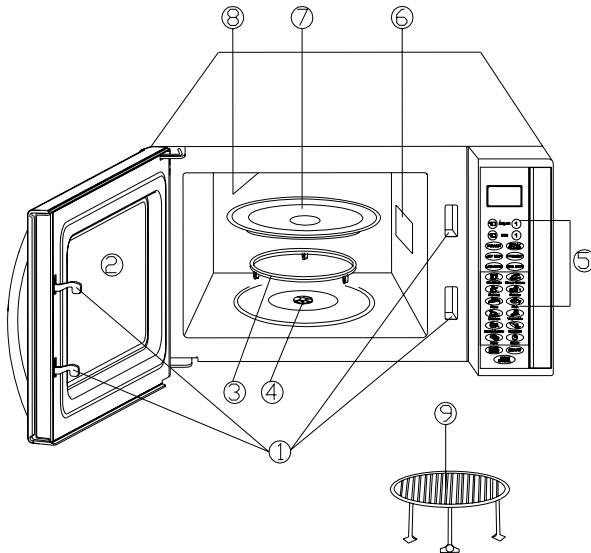

1. Door Safety Lock System
2. Oven Window
3. Roller ring
4. Shaft
5. Control Panel
6. Oven Air Vent
7. Glass tray
8. Grill Heater
9. Metal Rack

CONTROL PANEL

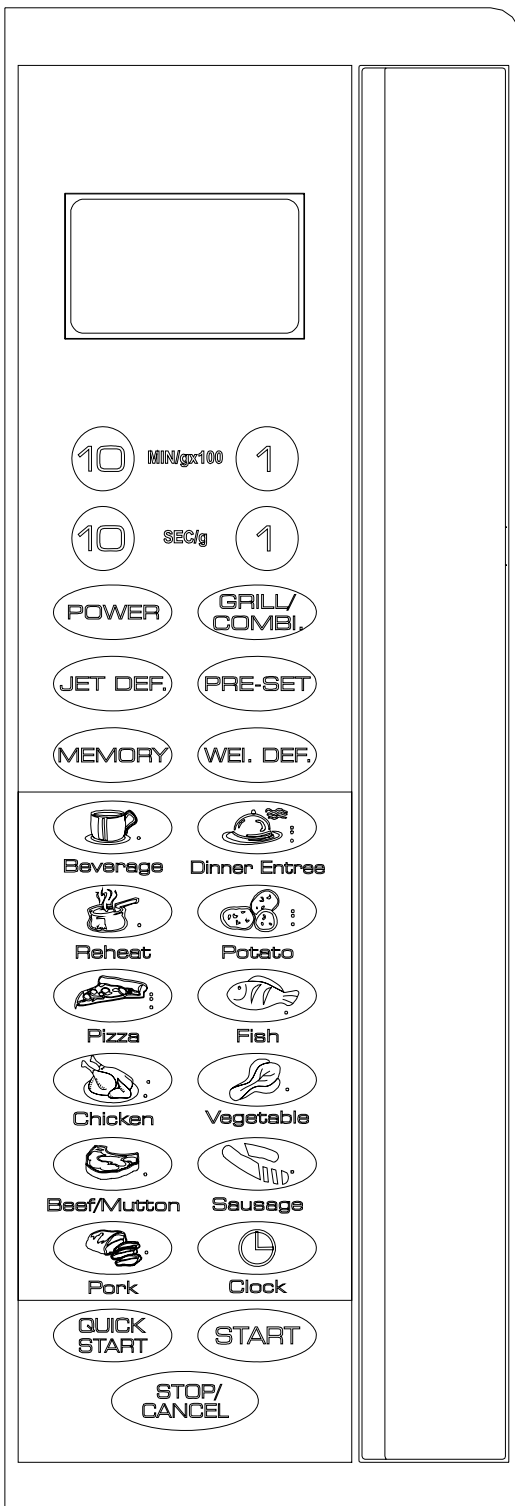

- MENU ACTION SCREEN
- ✳ Cooking time, power, action indicators, and clock time are displayed.

- NUMBER PADS
- ✳ Touch to set clock, cooking time or enter food weight.

- QUICK COOK BUTTONS
- ✳ Instant settings to cook popular foods.

- CLOCK
- ✳ Touch to set the digital clock.

- POWER
- ✳ Touch once or repeatedly to set microwave cooking power.

- GRILL/COMB.
- ✳ Press up to three times to choose a cooking mode.

- WEI. DEF.
- ✳ Programmed defrosting based on the weight of the foods to be defrosted.

- JET DEF.
- ✳ Quick defrost function that alternates defrost and stand times to quickly and effectively defrost foods.

- PRE-SET
- ✳ Delay start control allows you to put food into the oven and program it to start cooking at a later time.

- MEMORY
- ✳ Used for setting a multistage cooking program

- START
- ✳ Touch to start cooking

- QUICK START
- ✳ Touch to start the oven quickly at full microwave power

- STOP/CANCEL
- ✳ Touch to clear entry before setting a cooking program
- ✳ Touch once to temporarily stop cooking or twice to cancel cooking.
- ✳ Touch and hold to set child lock.



HOW TO SET THE OVEN CONTROLS

Each time a button is touched, a beep will sound to acknowledge the touch.

SETTING THE CLOCK

To enter the digital clock time, touch the CLOCK button once (or twice to set the clock time in 24 hour cycle by some models) and then press the number pads to set the time of day.

For example: to set the time of 6: 35 (A.M or P.M).

1. Choose to set the clock in 24 or 12-hour cycle by touching the CLOCK
2. Touch 1-MIN. button until the screen shows 6:00
3. Touch 10-SEC button 3 times and then touch 1-SEC button 5 times.
4. Touch CLOCK button again to confirm.

NOTE: You can check the clock time when cooking is in progress by touching the CLOCK button.

MICROWAVE COOKING

To cook with microwave, time and power level should be set. The longest cooking time to be set by touching the number pads is 99 min. 99 sec.

Suppose you want to cook for 5 minutes at 60% of microwave power.

1. Touch POWER button 3 times.
2. Touch 1-MIN. button five times.
3. Touch START button.

Note: during cooking, press POWER to show the cooking power level for 3 sec.

-----POWER BUTTON-----

By pressing the power button a number of times, you are selecting one of the following microwave power levels:

Press	Power Level	Description
Once	100% of total	High
Twice	80%	M. High
Thrice	60%	Medium
4 times	40%	M. Low
5 times	20%	Low
6 times	0%	zero

GRILL COOKING

Grill cooking is particularly useful for thin slices of meat, steaks, chops, kebabs, sausages or piece of chicken. It is also suitable for hot sandwiches and au gratin dishes.

Suppose you want to broil for 12 minutes.

1. Touch Grill/Comb. button once.
2. Touch 10-MIN. once and 1-MIN. twice.
3. Touch START button.

COMBINATION COOKING

Combination 1:

The longest cooking time is 99 min. 99 sec
35% time for microwave cooking, 65% for grill cooking. Recommended for fish, potatoes or au gratin.

Combination 2:

55% time for microwave cooking, 45% for grill cooking. Use for puddings omelets, baked potatoes and poultry.

Suppose you want to set the oven to COMBINATION cooking for 25 minutes.

1. Touch Grill/Comb. button twice or 3 times.
2. Touch 10-MIN. button 2 times and 1-MIN. button 5 times.
3. Touch START button.

AUTO COOK

For food or the following cooking mode, it is not necessary to program the duration and the cooking power. It is sufficient to indicate the type of food that you wish to cook as well as the weight of this food. In order to do this, press the individual icon pad of the food you are going to cook, the first of a number of preset weight parameters will appear, choose the one that's equivalent to the weight of food you have placed into the oven. The oven begins cooking once the START button is engaged.

For example, to cook 400g of fish.

1. Press FISH button a number of times to select food weight.
2. Press START button.

Auto Cook Menu

List	Food/cooking mode	Press to indicate weight of food
1	Beverage	<p>Weight parameters are used to determine the time needed to do the job.</p> <p>As you press the icon pads once or repeatedly, a number of pre-set weight (for beverage and dinner entree, number of servings) parameters display, when it comes up of the right figure which matches the weight of the food you have placed into the oven, push START button.</p>
2	Dinner entree	
3	Reheat	
4	Potato	
5	Pizza	
6	Fish	
7	Chicken	
8	Vegetable	
9	Beef /Mutton	
10	Sausage	
11	Pork	

Please note:

For some food, at the middle of cooking time, you may need to open the door to check its doneness and turn food over to obtain uniform cooking; but be careful to handle with care of very hot food in the oven. To resume cooking, just close the door, the oven will cook for the remaining time.

DEFROST BY WEIGHT

The oven allows the defrosting of meat, poultry, and seafood. The time and the defrosting power are adjusted automatically once the weight of food is programmed.

The maximum allowable weight for each category is shown below.

FOOD CATEGORY	MAXIMUM WEIGHT	DISPLAY
Meat	2300g	d1
Poultry	4000g	d2
Seafood	900g	d3

FOR EXAMPLE: Suppose you want to defrost 600g of shrimp.

1. Place the shrimp to be defrosted into the

oven.

2. Press WEI. DEF. 3 times.
3. Press 0.1 Kg (1g×100) button six times to enter weight.
4. Press START button.

For food exceeds the allowed weight for defrost, please use the Jet Defrost. If you happen to enter weight in excess of the maximum weight in the chart, the display will clear to allow reenters.

JET DEFROST

With JET DEFROST, you need to input defrosting time,

Suppose you want to set the oven to JET DEFROST for 5 minutes.

1. Touch JET DEF. button.

2. Touch 1-min. button 5 times.
3. Touch START button.

MULTI-STAGE COOKING

The oven can be programmed to do several consecutive functions.

Suppose you want to set the following cooking program:

- ① JET DEFROST;
- ② Microwave cooking;
- ③ Grill cooking.

Step:

1. If necessary, touch STOP/CANCEL pad once to reset the oven.
2. Input jet defrost program.
3. Touch MEMORY pad.
4. Input microwave and power level cooking program.
5. Touch MEMORY pad.
6. Input grill cooking program.
7. Touch START pad.

NOTE: JET DEFROST or WEIGHT DEFROST should be included only when it is set foremost in a multistage cooking program.

The respective lights will come on to indicate which stage the oven is operating in. After total time has elapsed, 3 beeps sound.

DELAY START

Delay start function allows the oven to start up in a later time. Suppose now the clock running at 11:10 and you want the oven to start cooking at 11:30.

Step:

1. Set a cooking program.
2. Touch PRE-SET pad.
3. Use the number pads to enter the time 11:30 when it should start.
4. Touch START pad.

NOTE: Make sure that the food is placed into the oven in advance before any cooking starts.

QUICK START

This feature allows you to start the oven quickly.

Press the QUICK START button once or repeatedly to set cooking time, the oven starts work at full power level immediately.

For example, to set the oven to cook for 2 minutes using this feature:

Press QUICK START button repeatedly until the screen shows the correct cooking times, the oven starts working immediately at full microwave power. You can add to cooking time by pressing this pad while the oven is already started.

CHILD LOCK

Use to prevent unsupervised operation of the oven by little children. The CHILD LOCK indicator will show up on display screen, and the oven cannot be operated while the CHILD LOCK is set.

To set the CHILD LOCK: Press and hold the STOP/CANCEL button for 3 seconds, a beep sounds and LOCK indicator lights.

To cancel the CHILD LOCK: Press and hold the STOP/CANCEL button for 3 seconds until lock indicator on display goes off.

SPECIAL FEATURE

AUTO REMINDER

After a cooking or defrosting program has completed, the oven will automatically continue to sound beeps every two minutes until the oven door is opened or the STOP/CANCEL button is pressed.

CLEANING AND CARE

1. Turn off the oven and remove the power plug from the wall socket before cleaning.
2. Keep the inside of the oven clean. When food splatters or spilled liquids adhere to oven walls, wipe with a damp cloth. Mild detergent may be used if the oven gets very dirty. Avoid the use of spray and other harsh cleaners as they may stain, streak or dull the door surface.
3. The outside surfaces should be cleaned with a damp cloth. To prevent damage to the operating parts inside the oven, water should not be allowed to seep into the ventilation openings.
4. Wipe the door and window on both sides, the door seals and adjacent parts frequently with a damp cloth to remove any spills or splatters. Do not use abrasive cleaner.
5. Do not allow the control panel to become wet. Clean with a soft, damp cloth. When cleaning the control panel, leave oven door open to prevent oven from accidentally turning on.
6. If steam accumulates inside or around the outside of the oven door, wipe with a soft cloth. This may occur when the microwave oven is operated under high humidity condition. And it is normal.
7. It is occasionally necessary to remove the glass tray for cleaning. Wash the tray in warm sudsy water or in a dishwasher.
8. The roller ring and oven floor should be cleaned regularly to avoid excessive noise. Simply wipe the bottom surface of the oven with mild detergent. The roller ring may be washed in mild sudsy water or dishwasher. When removing the roller ring from cavity floor for cleaning, be sure to replace in the proper position.
9. Remove odors from your oven by combining a cup of water with the juice and skin of one lemon in a deep microwaveable bowl, microwave for 5 minutes. Wipe thoroughly and dry with a soft cloth.
10. When it becomes necessary to replace the oven light, please consult a dealer to have it replaced.
11. The oven should be cleaned regularly and any food deposits removed. Failure to maintain the oven in a clean condition could lead to deterioration of the surface that could adversely affect the life of the appliance and possibly result in a hazardous situation.
12. Please do not dispose this appliance into the domestic rubbish bin, it should be disposed to the particular disposal center provided by the municipalities.

FCC Warning statement:

The Device complies with part 18 of the FCC rules, Operation is subject to the following conditions: (1) This device may not cause harmful interference, and (2) this device must accept any interference received, including interference that may cause undersired operation