

Model: P100N30(X)H-(Y)



Microwave Oven

User's manual

Please read these instructions carefully before installing and operating the oven.
Record in the space below the SERIAL NO. found on the nameplate on your oven
and retain this information for future reference.
Please save sales receipt for warranty.

PRECAUTIONS TO AVOID POSSIBLE EXPOSURE TO EXCESSIVE MICROWAVE ENERGY

1. Do not attempt to operate this oven with the door-open since open-door operation can result in harmful exposure to microwave energy. It is important not to defeat or tamper with the safety interlocks.
2. Do not place any object between the oven front face and the door or allow soil or cleaner residue to accumulate on sealing surfaces.
3. Do not operate the oven if it is damaged. It is particularly important that the oven door close properly and that there is no damage to the:
 1. Door (bent),
 2. Hinges and latches (broken or loosened),
 3. Door seals and sealing surfaces.
4. The oven should not be adjusted or repaired by anyone except properly qualified service personnel.

CONTENT

PRECAUTIONS TO AVOID POSSIBLE EXPOSURE TO EXCESSIVE MICROWAVE ENERGY	1
IMPORTANT SAFETY INSTRUCTIONS.....	2
INSTALLATION GUIDE	4
GROUNDING INSTRUCTIONS.....	4
UTENSILS GUIDE	5
COOKING TECHNIQUES.....	7
SPECIFICATIONS.....	8
PART NAMES	8
CONTROL PANEL	9
OPERATION INSTRUCTIONS	10
Setting the clock.....	10
Setting the timer	10
Express cook.....	10
Setting micro. cooking program.....	11
Speed defrost	11
Cook by weight.....	12
Defrost by weight.....	12
Setting child lock	13
SENSOR MENU COOK SETTINGS	13
CLEANING AND CARE.....	15

IMPORTANT SAFETY INSTRUCTIONS

When using electrical appliances, basic safety precautions should be followed, including the following:

WARNING - To reduce the risk of burns, electric shock, fire, and injury to persons or exposure to excessive microwave energy:

1. Read all instructions before using the appliance.
2. Read and follow the specific "PRECAUTIONS TO AVOID POSSIBLE EXPOSURE TO EXCESSIVE MICROWAVE ENERGY" on page 1.
3. This appliance must be grounded. Connect only to properly grounded outlet. See "GROUNDING INSTRUCTIONS" on page 4.
4. Install or locate this appliance only in accordance with the provided installation instructions.
5. Some products such as whole eggs and sealed containers -for example, closed glass jars- are able to explode and should not be heated in this oven.
6. Use this appliance only for its intended use as described in this manual. Do not use corrosive chemicals or vapors in this appliance. This type of oven is specifically designed to heat, cook, or dry food. It is not designed for industrial or laboratory use.
7. As with any appliance, close supervision is necessary when used by children.
8. To reduce the risk of fire in the oven cavity:
 - a. Do not overcook food. Carefully attend appliance when paper, plastic, or other combustible materials are placed inside the oven to facilitate cooking.
 - b. Remove wire twist-ties from paper or plastic bags before placing bag in oven.
 - c. If materials inside the oven should ignite, keep oven door closed, turn oven off, and disconnect the power cord or shut off power at the fuse or circuit breaker panel.
 - d. Do not use the cavity for storage purposes. Do not leave paper products, cooking utensils or food in the cavity when not in use.
9. Liquids, such as water, coffee, or tea can be overheated beyond the boiling point without appearing to be boiling due to surface tension of the liquid. Visible bubbling or boiling when the container is removed from the microwave oven is not always present. **THIS COULD RESULT IN VERY HOT LIQUIDS SUDDENLY BOILING OVER WHEN A SPOON OR OTHER UTENSIL IS INSERTED INTO THE LIQUID.** To reduce the risk of injury to person:
 - 1) Do not overheat the liquid.
 - 2) Stir the liquid both before and halfway through heating it.
 - 3) Do not use straight-sided containers with narrow necks.
 - 4) After heating, allow the container to stand in the microwave oven for a short time before removing the container.
 - 5) Use extreme care when inserting a spoon or other utensil into the container.

SAVE THESE INSTRUCTIONS

10. Do not heat oil or fat for deep-frying. It is difficult to control the temperature of oil in microwave oven.
11. Pierce foods with heavy skins such as potatoes, whole squash, apples and chestnuts before cooking.
12. The contents of feeding bottles and baby jars should be stirred or shaken and the temperature should be checked before serving in order to avoid burns.
13. Cooking utensils may become hot because of heat transferred from the heated food. Potholders may be needed to handle the utensil.
14. Do not cover or block any openings on the appliance.
15. Do not store or use this appliance outdoors. Do not use this product near water, for example, near a kitchen sink, in a wet basement, near a swimming pool, or similar locations.
16. Do not operate this appliance if it has a damaged cord or a plug, if it is not working properly or if it has been damaged or dropped.
17. Do not immerse cord or plug in water. Keep cord away from heated surface. Do not let cord hang over edge of table or counter.
18. Use only thermometers, which are specifically designed for use in microwave ovens.
19. Do not operate any heating or cooking appliance beneath this appliance.
20. Be certain the glass tray and roller rings are in place when you operate the oven
21. This appliance should be serviced only by qualified service personnel, contact nearest authorized service facility for examination, repair, or adjustment.
22. When cleaning surfaces of door and oven that comes together on closing the door, use only mild, nonabrasive soaps, or detergents applied with a sponge or soft cloth.
23. This equipment generates, uses and can radiate radio frequency energy and, if not installed and used in accordance with the instructions, may cause harmful interference to radio communications. However, there is no guarantee that interference will not occur in a particular installation. If this equipment does cause harmful interference to radio or television reception, which can be determined by turning the equipment off and on, the user is encouraged to try to correct the interference by one or more of the following measures:
 - Reorient or relocate the receiving antenna.
 - Increase the separation between the equipment and receiver.
 - Connect the equipment into an outlet on a circuit different from that to which the receiver is connected.
 - Consult the dealer or an experienced radio/TV technician for help.

SAVE THESE INSTRUCTIONS

INSTALLATION GUIDE

1. Make sure that all the packing materials are removed from the inside of the door.
2. Check the oven for any damage, such as misaligned or bent door, damaged door seals and sealing surface, broken or loose door hinges and latches and dents inside the cavity or on the door. If there is any damage, do not operate the oven and contact qualified service personnel.
3. This microwave oven must be placed on a flat, stable surface to hold its weight and the heaviest food likely to be cooked in the oven.
4. Do not place the oven where heat, moisture, or high humidity are generated, or near combustible materials.
5. For correct operation, the oven must have sufficient air flow. Allow 20cm of space above the oven, 10cm at back and 5cm at both sides. Do not cover or block any openings on the appliance. Do not remove feet on which oven stands.
6. The appliance shall be only used on a countertop over 3 feet (914mm) above the floor.
7. Do not operate the oven without glass tray, roller support, and shaft in their proper positions.
8. Make sure that the power cord is undamaged and does not run under the oven or over any hot or sharp surface.
9. The socket must be readily accessible so the microwave oven can be easily unplugged in an emergency.

GROUNDING INSTRUCTIONS

This appliance must be grounded. In the event of an electrical short circuit, grounding reduces risk of electric shock by providing an escape wire for the electric current.

WARNING Improper use of the grounding plug can result in a risk of electric shock.

Consult a qualified electrician or serviceman if the grounding instructions are not completely understood, or if doubt exists as to whether the appliance is properly grounded, and either:

- 1) If it is necessary to use an extension cord, use only a 3-wire extension cord that has a 3-blade grounding plug and a 3-slot receptacle that will accept the plug on the appliance. The marked rating of the extension cord shall be equal to or greater than the electrical rating of the appliance, or 2) Do not use an extension cord. If the power supply cord is too short, have a qualified electrician or serviceman install an outlet near the appliance.

Electrical Requirements

The electrical requirements are a 120 volt 60 Hz, AC only, 20 amp. It is recommended that a separate circuit serving only the oven be provided. The oven is equipped with a 3-prong grounding plug. It must be plugged into a wall receptacle that is properly installed and

grounded.

Power Supply Cord

1. A short power supply cord is provided to reduce the risks resulting from becoming entangled in or tripping over a longer cord.
2. Longer cord sets or extension cords are available and may be used if care is exercised in their use.
3. If long cord or extension cord is used:
 - a) The marked electrical rating of the cord set or extension cord should be at least as great as the electrical rating of the appliance.
 - b) The extension cord must be a grounding-type 3-wire cord, and The longer cord should be arranged so that it will not drape over the counter top or table top where it can be pulled on by children or tripped over unintentionally.

Notes:

If you have any questions about the grounding or electrical instructions, consult a qualified electrician or service person.

Neither the manufacturer nor the dealer can accept any liability for damage to the oven or personal injury resulting from failure to observe the electrical connection procedures.

Radio or TV Interference

Should there be any interference caused by the microwave oven to your radio or TV, check that the microwave oven is on a different circuit, relocated the radio or TV as far away from the oven as feasible or check position and signal of receiving antenna.

UTENSILS GUIDE

This section lists which utensils can be used in the microwave, which ones have limited use for short periods, and which ones should not be used in the microwave.



RECOMMENDED

Microwave browning dish — Use to brown the exterior of small items such as steaks, chops, or pancakes. Follow the directions provided with your browning dish.

Microwaveable plastic wrap — Use to retain steam. Leave a small opening for some steam to escape and avoid placing it directly on the food.

Paper towels and napkins — Use for short-term heating and covering; these absorb

excess moisture and prevent spattering. Do not use recycled paper towels, which may contain metal and could ignite.

Glass and glass-ceramic bowls and dishes — Use for heating or cooking.

Paper plates and cups — Use for short-term heating at low temperatures. Do not use recycled paper, which may contain metal and could ignite.

Wax paper — Use as a cover to prevent spattering.

Thermometers — Use only those labeled "Microwave Safe" and follow all directions. Check the food in several places. Conventional thermometers may be used on microwave food once the food has been removed from the oven.

A LIMITED USE

Aluminum foil — Use narrow strips of foil to prevent overcooking of exposed areas. Using too much foil can damage your oven, so be careful. You should keep distance of 1 inch (2.54cm) between aluminum foil and cavity.

Ceramic, porcelain, and stoneware— Use these if they are labeled "Microwave Safe". If they are not labeled, test them to make sure they can be used safely.

Plastic — Use only if labeled "Microwave Safe". Other plastics can melt.

X Not Recommended

Glass jars and bottles — Regular glass is too thin to be used in a microwave. It can shatter and cause damage and injury.

Paper bags — These are a fire hazard, except for popcorn bags that are designed for microwave use.

Styrofoam plates and cups — These can melt and leave an unhealthy residue on food.

Plastic storage and food containers — Containers such as margarine tubs can melt in the microwave.

Metal utensils — These can damage your oven. Remove all metal before cooking.

Note:

Should you wish to check if a dish is safe for microwaving, place the empty dish in the oven and microwave on HIGH for 30 seconds. A dish which becomes very hot should not be used.

COOKING TECHNIQUES

Your microwave makes cooking easier than conventional cooking, provided you keep these considerations in mind:

STIRRING

Stir foods such as casseroles and vegetables while cooking to distribute heat evenly. Food at the outside of the dish absorbs more energy and heats more quickly, so stir from the outside to the center. The oven will turn off when you open the door to stir your food.

ARRANGEMENT

Arrange unevenly shaped foods, such as chicken pieces or chops, with the thicker, meatier parts toward the outside of the turntable where they receive more microwave energy. To prevent overcooking, place delicate areas, such as asparagus tips, toward the center of the turntable.

SHIELDING

Shield food with narrow strips of aluminum foil to prevent overcooking. Areas that need shielding include poultry wing tips, the ends of poultry legs, and corners of square baking dishes. Use only small amounts of aluminum foil. Larger amounts can damage your oven.

TURNING

Turn foods over midway through cooking to expose all parts to microwave energy. This is especially important with large foods such as roasts.

STANDING

Foods cooked in the microwave build up internal heat and continue to cook for a few minutes after heating stops. Let foods stand to complete cooking, especially foods such as cakes and whole vegetables. Roasts need this time to complete cooking in the center without overcooking the outer areas. All liquids, such as soup or hot chocolate, should be shaken or stirred when cooking is complete. Let liquids stand a moment before serving. When heating baby food, stir well at removal and test the temperature before serving.

ADDING MOISTURE

Microwave energy is attracted to water molecules. Food that is uneven in moisture content should be covered or allowed to stand so that the heat disperses evenly. Add a small amount of water to dry food to help it cook.

SPECIFICATIONS

Power Consumption:	120V~60Hz, 1500W (Microwave)
Output:	1000W
Operation Frequency:	2450MHz
Outside Dimensions(H×W×D):	11 ¹³ / ₁₆ "(H)×21 ⁴ / ₁₆ "(W)×15 ¹² / ₁₆ "(D)
Oven Cavity Dimensions(H×W×D):	9 ⁷ / ₁₆ "(H)×13 ¹⁵ / ₁₆ "(W)×14 ¹ / ₈ "(D)
Oven Capacity:	1.06 cu.ft
Cooking Uniformity:	Turntable System
Net Weight:	Approx. 35.3lb.

PART NAMES

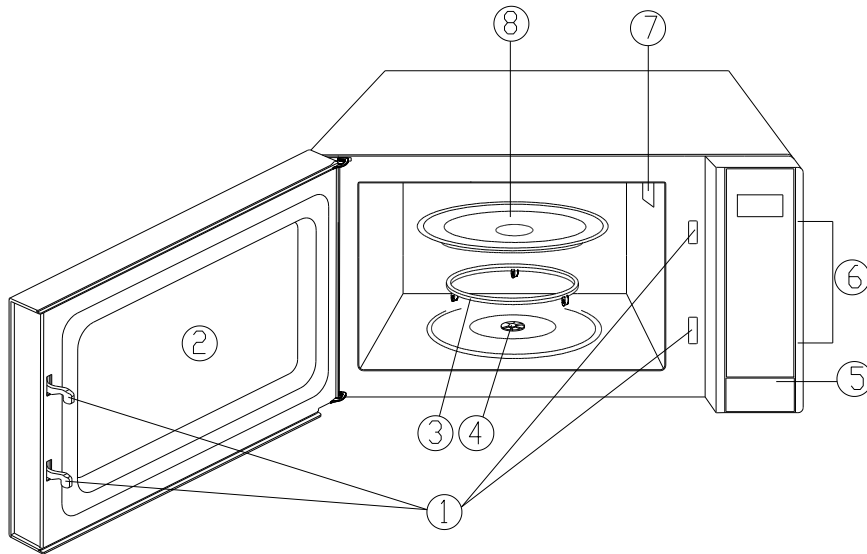

1. Door Safety Lock System
2. Oven Window
3. Roller Ring
4. Shaft
5. Door Release Button
6. Control Panel
7. Wave Guide(Please do not remove the mica plate covering the wave guide)
8. Glass Tray

CONTROL PANEL

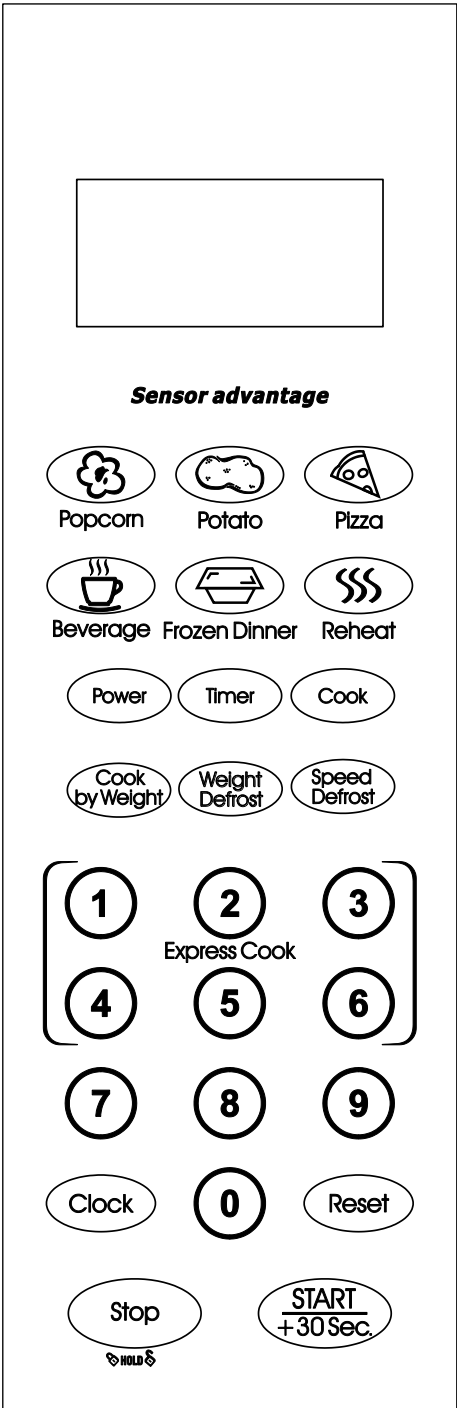

- **MENU ACTION SCREEN**
Cooking time, power, indicators and present time are displayed.

- **QUICK COOK BUTTONS**
Instant settings to cook popular foods.

- **POWER**
Use to set microwave power levels.

- **TIMER**
Timer functions independently, even while a cooking program is in process.

- **COOK**
Use for multi-stage cooking. Enables cooking at multiple power and time settings automatically.

- **COOK BY WEIGHT**
Programmed cooking based on weight of foods.

- **WEIGHT DEFROST**
Programmed defrosting based on the weight of the foods to be defrosted.

- **SPEED DEFROST**
Speed Defrost function that alternates defrost and stand times to quickly and effectively defrost foods.

- **NUMBER PADS(0-9)**
Touch to set time or amount.

- **CLOCK**
Touch to set the clock time.

- **RESET**
Touch to clear all previous settings.

- **START/+30SEC**
Touch to start cooking or use to set quick start cooking program.

- **STOP**
Touch to stop the program.

OPERATION INSTRUCTIONS

● SIGNALS DURING OVEN SETTINGS

- ✓ ONE SIGNAL: Oven accepts the entry.
- ✓ TWO SIGNALS: Oven does not accept the entry, please check and try again.
- End will display with beeps to remind the program is over, and it will sound every two minutes until you press any pad or open the door.
- During cooking program, press STOP to pause the program, then press RESET to cancel the program.

SETTING THE CLOCK

1. Touch CLOCK pad.
 2. Use the number pads to enter clock time.
 3. Touch CLOCK pad again.
- ✓ This is a 12 hour clock. When the oven is first plugged in or when power resumes after a power interruption, the display will show ENTER CLOCK TIME. If you prefer not to have the clock displayed, touch RESET. In waiting mode or cooking in a session, press CLOCK pad to check the current time

SETTING THE TIMER

1. In any mode, touch TIMER pad.
 2. Enter the amount of time by touching the number pads.
 3. Touch START/+30SEC pad.
- ✓ The maximum time you can enter is 99 minutes and 59 seconds.
 - ✓ Touch TIMER pad once, the timer time will display for 5 seconds, and then touch RESET to cancel TIMER during timing process.

EXPRESS COOK

In standby mode, press the number pad (from 1 to 6) to enter cooking time (between 1 minute and 6 minutes), and the oven will start automatically at 100% high power level.

SETTING MICRO. COOKING PROGRAM

A. One-stage cooking

1. Use the number pads to set a cooking time. The longest cooking time is 99 minutes and 59 seconds.
2. If you want to set a power level other than 100% power, touch POWER pad, and then use the number pads to enter the power level. You can set the power level from 0 to 100% (no need touch number pads when setting 100% power). During cooking you can check the power level by touching POWER pad.
3. Touch START/+30SEC pad to start cooking.

Use digit to set a cooking power level:

Number pad	Cooking power	Number pad	Cooking power
1,0	100%	4	40%
9	90%	3	30%
8	80%	2	20%
7	70%	1	10%
6	60%	0	0%
5	50%		

B. Two-stage cooking

Some recipes require different stages of cooking at different power levels.

1. SET STAGE 1:

Follow steps 1 and 2 in "One-stage cooking". DO NOT TOUCH START/+30SEC pad

2. SET STAGE 2:

Touch COOK pad then enter proper cooking time and (lower) power level. (Most 2-stage recipes use lower power for second stage.)

3. Touch START/+30SEC pad.

SPEED DEFROST

1. Touch SPEED DEFROST pad.
 2. Enter desired defrosting time by touching correct number pads. (The longest cooking time is 99 minutes and 59 seconds.)
 3. Touch START/+30SEC pad.
- ✓ After setting SPEED DEFROST, oven can be programmed to automatically switch to one or two-stage cooking.
 - ✓ For speed defrost and one stage cooking, follow steps above. Before touching START/+30SEC pad, touch COOK pad, and enter time and power level. Then touch START/+30SEC pad.

- ✓ For speed defrost and two-stage cooking, follow steps above. Before touching START/+30SEC pad, enter two-stage cooking programs.

COOK BY WEIGHT

1. Touch COOK BY WEIGHT pad.
2. Enter the one digit code by touching the correct number pad (1~3).
3. Enter weight by touching number pads.
4. Touch START/+30SEC pad.

Cook By Weight Code Description

CODE	TYPE	MAX WEIGHT
1	Beef	5 lb. 16 oz.
2	Mutton	5 lb. 16 oz.
3	Pork	5 lb. 4 oz.

Note:

- ✓ Weight must be in pounds and ounces.
- ✓ Ounce weights less than 10 must be preceded by a 0. If label gives weight in pounds only, change the fraction of a pound to ounces using the following chart.

Converting Fractions of a Pound to Ounces

Fractions of a pound	Ounces	Fractions of a pound	Ounces
Less than .03	0	.54 to .59	9
.03 to .09	1	.60 to .65	10
.10 to .15	2	.66 to .71	11
.16 to .21	3	.72 to .78	12
.22 to .27	4	.79 to .84	13
.28 to .34	5	.85 to .90	14
.35 to .40	6	.91 to .97	15
.41 to .46	7	above .97	go to next even
.47 to .53	8		

- ✓ During cooking, the system will pause automatically and sound to remind user to turn food over. After that, touch START/+30SEC pad to resume cooking.

DEFROST BY WEIGHT

1. Touch WEIGHT DEFROST pad.
2. Enter weight by touching number pads.
3. Touch START/+30SEC pad.

NOTE:

- ✓ Weight must be in pounds and ounces. Ounce weights less than 10 must be preceded by a 0. If label gives weight in pounds only, change the fraction of a pound to ounces by using the chart given above. The maximum weight is 5lb.16oz.
- ✓ During defrosting the system will sound to remind user to turn food over, then touch START/+30SEC pad to resume defrosting.

SETTING CHILD LOCK

The safety lock prevents unsupervised operation by children.

1. To set, in standby mode, press and hold RESET pad for 3 seconds. Lock indicator will appear on the display.
2. To cancel, in standby mode, press and hold RESET pad for 3 seconds. Lock indicator will disappear.

SENSOR MENU COOK SETTINGS

The sensor features detect the increasing humidity released during cooking. The oven automatically adjusts the cooking time to various types and amounts of food.

In waiting mode, press corresponding menu pad once, "CODE", "COOK", "SENS" will display, and the oven start to cook.

Use single digit to set sensor cooking program:

Sensor menu	Weight	Note
Popcorn	3.5oz	<ul style="list-style-type: none">● The result of Sensor Cook depends on factors such as voltage fluctuation, the shape and size of food, your personal preference as to the doneness of certain foods and even how well you happen to place food in the oven. If you find the result at any rate not quite satisfactory, please adjust the cooking time a little bit accordingly.● For beverage, press BEVERAGE pad repeatedly to choose 1, 2 or 3 cups, and then the oven will start cooking automatically.
Potato	6~24oz	
Pizza	6~18oz	
Beverage	200ml/cup	
Frozen dinner	8~28oz	
Reheat	8~28oz	

NOTE:

- ✓ When press sensor menu(the door is turn off), the display will show COOK, CODE, SENS. (If

the door open, when press the sensor menu pad ,there are two beep will sound to remind user .)

- ✓ Cooking run a period of time, error may occur to the system sensor or else, in this case, the system will stop automatically with the display showing “E-5”, two beeps sound every 2 seconds until RESET is pressed.
- ✓ When steam is sensed, corresponding cooking time appears on display and begins counting down.
- ✓ During the longest sensor time, if the oven cannot test the cooking time according to the steam which produced by food in the oven, the system will return to waiting mode.

CLEANING AND CARE

1. Turn off the oven and remove the power plug from the wall socket before cleaning.
2. Keep the inside of the oven clean. When food splatters or spilled liquids adhere to oven walls, wipe with a damp cloth. Mild detergent may be used if the oven gets very dirty. Avoid the use of spray and other harsh cleaners as they may stain, streak or dull the door surface.
3. The outside surfaces should be cleaned with a damp cloth. To prevent damage to the operating parts inside the oven, water should not be allowed to seep into the ventilation openings.
4. Wipe the window on both sides with a damp cloth to remove any spills or splatters.
5. Do not allow the control panel to become wet. Clean with a soft, damp cloth. When cleaning the control panel, leave oven door open to prevent oven from accidentally turning on.
6. If steam accumulates inside or around the outside of the oven door, wipe with a soft cloth. This may occur when the microwave oven is operated under high humidity conditions. In such case, it is normal.
7. It is occasionally necessary to remove the glass tray for cleaning. Wash the tray in warm sudsy water or in a dishwasher.
8. The roller ring and oven floor should be cleaned regularly to avoid excessive noise. Simply wipe the bottom surface of the oven with mild detergent. The roller ring may be washed in mild sudsy water or dishwasher. When removing the roller ring from cavity floor for cleaning, be sure to replace in the proper position.
9. Remove odors from your oven by combining a cup of water with the juice and skin of one lemon in a deep microwaveable bowl, microwave for 5 minutes. Wipe thoroughly and dry with a soft cloth.
10. When it becomes necessary to replace the oven light, please consult a dealer to have it replaced.
11. The oven should be cleaned regularly and any food deposits removed. Failure to maintain the oven in a clean condition could lead to deterioration of the surface that could adversely affect the life of the appliance and possibly result in a hazardous situation.
12. Please do not dispose this appliance into the domestic rubbish bin, it should be disposed to the particular disposal center provided by the municipalities.