

Microwave Oven D10034MSLR

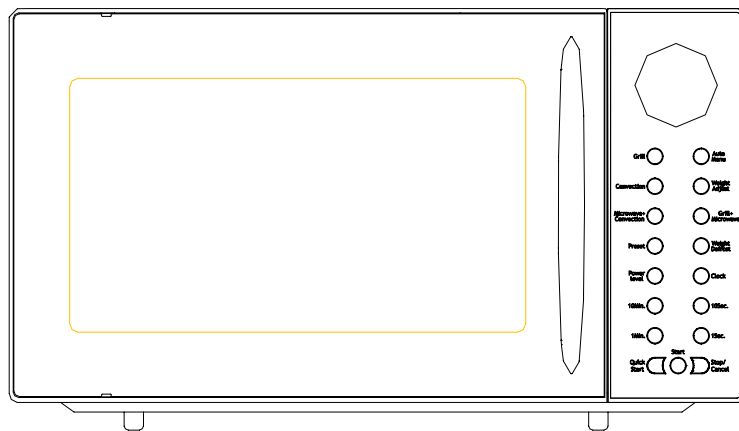

1. READ these instructions carefully before installing and operating the oven.

Keep them for further reference.

2. Record in the space below the SERIAL NO. found on the nameplate on your oven and retain this information for future reference.

SERIAL NO.:

Please save sales receipt for warranty.

PRECAUTIONS TO AVOID POSSIBLE EXPOSURE TO EXCESSIVE MICROWAVE ENERGY

- (a) Do not attempt to operate this oven with the door-open since open-door operation can result in harmful exposure to microwave energy. It is important not to defeat or tamper with the safety interlocks.
- (b) Do not place any object between the oven front face and the door or allow soil or cleaner residue to accumulate on sealing surfaces.
- (c) Do not operate the oven if it is damaged. It is particularly important that the oven door close properly and that there is no damage to the :
 - ① Door (bent),
 - ② Hinges and latches (broken or loosened),
 - ③ Door seals and sealing surfaces.
- (d) The oven should not be adjusted or repaired by anyone except properly qualified service personnel.

CONTENTS

IMPORTANT SAFETY INSTRUCTIONS	2
GROUNDING INSTRUCTIONS	3
UTENSILS GUIDE	4
COOKING TECHNIQUES	6
BEFORE YOU CALL FOR SERVICE	7
SPECIFICATIONS	7
PART NAMES	7
CONTROL PANEL	8
HOW TO SET THE OVEN CONTROLS	9
OTHER CONVENIENT FEATURES	12
CLEANING AND CARE	13

IMPORTANT SAFETY INSTRUCTIONS

When using electrical appliances, basic safety precautions should be followed, including the following:

WARNING - To reduce the risk of burns, electric shock, fire, injury to persons or exposure to excessive microwave energy:

1. Read all instructions before using the appliance.
2. Read and follow the specific "PRECAUTIONS TO AVOID POSSIBLE EXPOSURE TO EXCESSIVE MICROWAVE ENERGY" on page 1.
3. This appliance must be grounded. Connect only to properly grounded outlet. See "GROUNDING INSTRUCTIONS" on page 3.
4. Install or locate this appliance only in accordance with the provided installation instructions.
5. Some products such as whole eggs and sealed containers -for example, closed glass jars- are able to explode and should not be heated in this oven.
6. Use this appliance only for its intended use as described in this manual. Do not use corrosive chemicals or vapors in this appliance. This type of oven is specifically designed to heat, cook, or dry food. It is not designed for industrial or laboratory use.
7. As with any appliance, close supervision is necessary when used by children.
8. To reduce the risk of fire in the oven cavity:
 - a. Do not overcook food. Carefully attend appliance when paper, plastic, or other combustible materials are placed inside the oven to facilitate cooking.
 - b. Remove wire twist-ties from paper or plastic bags before placing bag in oven.
 - c. If materials inside the oven should ignite, keep oven door closed, turn oven off, and disconnect the power cord or shut off power at the fuse or circuit breaker panel.
 - d. Do not use the cavity for storage purposes. Do not leave paper products, cooking utensils or food in the cavity when not in use.
9. Liquids, such as water, coffee, or tea are able to be overheated beyond the boiling point without appearing to be boiling due to surface tension of the liquid. Visible bubbling or boiling when the container is removed from the microwave oven is not always present. THIS COULD RESULT IN VERY HOT LIQUIDS SUDDENLY BOILING OVER WHEN A SPOON OR OTHER UTENSIL IS INSERTED INTO THE LIQUID. To reduce the risk of injury to person:
 - a. Do not overheat the liquid.
 - b. Stir the liquid both before and halfway through heating it.
 - c. Do not use straight-sided containers with narrow necks.
 - d. After heating, allow the container

- to stand in the microwave oven for a short time before removing the container.
- e. Use extreme care when inserting a spoon or other utensil into the container.
10. Do not heat oil or fat for deep-frying. It is difficult to control the temperature of oil in microwave oven.
 11. Pierce foods with heavy skins such as potatoes, whole squash, apples and chestnuts before cooking.
 12. The contents of feeding bottles and baby jars should be stirred or shaken and the temperature should be checked before serving in order to avoid burns.
 13. Cooking utensils may become hot because of heat transferred from the heated food. Potholders may be needed to handle the utensil.
 14. Do not cover or block any openings on the appliance.
 15. Do not store or use this appliance outdoors. Do not use this product near water, for example, near a kitchen sink, in a wet basement, near a swimming pool, or similar locations.
 16. Do not operate this appliance if it has a damaged cord or a plug, if it is not working properly or if it has been damaged or dropped.
 17. Do not immerse cord or plug in water. Keep cord away from heated surface. Do not let cord hang over edge of table or counter.
 18. Use only thermometers, which are specifically designed for use in microwave ovens.
 19. Do not operate any heating or cooking appliance beneath this appliance.
 20. Be certain the glass tray and roller rings are in place when you operate the oven.
 21. **WARNING:** It is hazardous for anyone other than a trained person to carry out any service or repair operation which involves the removal of any cover which gives protection against exposure to microwave energy. If there is any damage, do not operate the oven and contact your dealer
 22. This appliance should be serviced only by qualified service personnel. Contact nearest authorized service facility for examination, repair, or adjustment.

GROUNDING INSTRUCTIONS

This appliance must be grounded. In the event of an electrical short circuit, grounding reduces risk of electric shock by providing an escape wire for the electric current.

WARNING: Improper use of the grounding plug can result in a risk of electric shock.

SAVE THESE INSTRUCTIONS

Electrical Requirements

The electrical requirements are a 120 volt 60 Hz, AC only, 20 amp. It is recommended that a separate circuit serving only the oven be provided. The oven is equipped with a 3-prong grounding plug. It must be plugged into a wall receptacle that is properly installed and grounded.

Power Supply Cord

1. A short power supply cord is provided to reduce the risks resulting from becoming entangled in or tripping over a longer cord.
2. Longer cord sets or extension cords are available and may be used if care is exercised in their use.
3. If long cord or extension cord is used:
 - a) The marked electrical rating of the cord set or extension cord should be at least as great as the electrical rating of the appliance.
 - b) The extension cord must be a grounding-type 3-wire cord, and The longer cord should be arranged so that it will not drape over the counter top or table top where it can be pulled on by children or tripped over unintentionally.

Notes:

If you have any questions about the grounding or electrical instructions, consult a qualified electrician or service person.

Neither Galanz nor the dealer can accept any liability for damage to the oven or personal injury resulting from failure to observe the electrical connection procedures.

UTENSILS GUIDE

This section lists which utensils can be used in the microwave, which ones have limited use for short periods, and which ones should not be used in the microwave.

Recommended

- **Microwave browning dish** — Use to brown the exterior of small items such as steaks, chops, or pancakes. Follow the directions provided with your browning dish.
- **Microwaveable plastic wrap** — Use to retain steam. Leave a small opening for some steam to escape and avoid placing it directly on the food.
- **Paper towels and napkins** — Use for short-term heating and covering; these absorb excess moisture and prevent spattering. Do not use recycled paper towels, which may contain metal and could ignite.

SAVE THESE INSTRUCTIONS

- **Glass and glass-ceramic bowls and dishes** — Use for heating or cooking.
- **Paper plates and cups** — Use for short-term heating at low temperatures. Do not use recycled paper, which may contain metal and could ignite.
- **Wax paper** — Use as a cover to prevent spattering.
- **Thermometers** — Use only those labeled “Microwave Safe” and follow all directions. Check the food in several places. Conventional thermometers may be used on microwave food once the food has been removed from the oven.

Limited Use

- **Aluminum foil** — Use narrow strips of foil to prevent overcooking of exposed areas. Using too much foil can damage your oven, so be careful.
- **Ceramic, porcelain, and stoneware** — Use these if they are labeled “Microwave Safe”. If they are not labeled, test them to make sure they can be used safely.
- **Plastic** — Use only if labeled “Microwave Safe”. Other plastics can melt.
- **Straw, wicker, and wood** — Use only for short-term heating, such as warming dinner rolls for a few seconds; baskets and bowls may be flammable.

Not Recommended

- **Glass jars and bottles** — Regular glass is too thin to be used in a microwave. It can shatter and cause damage and injury.
- **Paper bags** — These are a fire hazard, except for popcorn bags that are designed for microwave use.
- **Styrofoam plates and cups** — These can melt and leave an unhealthy residue on food.
- **Plastic storage and food containers** — Containers such as margarine tubs can melt in the microwave.
- **Metal utensils** — These can damage your oven. Remove all metal before cooking.

Note: Should you wish to check if a dish is safe for microwaving, place the empty dish in the oven and microwave on HIGH for 30 seconds. A dish which becomes very hot should not be used.

SAVE THESE INSTRUCTIONS

COOKING TECHNIQUES

Your microwave makes cooking easier than conventional cooking, provided you keep these considerations in mind:

Stirring

Stir foods such as casseroles and vegetables while cooking to distribute heat evenly. Food at the outside of the dish absorbs more energy and heats more quickly, so stir from the outside to the center. The oven will turn off when you open the door to stir your food.

Arrangement

Arrange unevenly shaped foods, such as chicken pieces or chops, with the thicker, meatier parts toward the outside of the turntable where they receive more microwave energy. To prevent overcooking, place delicate areas, such as asparagus tips, toward the center of the turntable.

Shielding

Shield food with narrow strips of aluminum foil to prevent overcooking. Areas that need shielding include poultry wing-tips, the ends of poultry legs, and corners of square baking dishes. Use only small amounts of aluminum foil. Larger amounts can damage your oven.

Turning

Turn foods over midway through cooking to expose all parts to microwave energy. This is especially important with large foods such as roasts.

Standing

Foods cooked in the microwave build up internal heat and continue to cook for a few minutes after heating stops. Let foods stand to complete cooking, especially foods such as cakes and whole vegetables. Roasts need this time to complete cooking in the center without overcooking the outer areas. All liquids, such as soup or hot chocolate, should be shaken or stirred when cooking is complete. Let liquids stand a moment before serving. When heating baby food, stir well at removal and test the temperature before serving.

Adding moisture

Microwave energy is attracted to water molecules. Food that is uneven in moisture content should be covered or allowed to stand so that the heat disperse evenly. Add a small amount of water to dry food to help it cook.

SAVE THESE INSTRUCTIONS

BEFORE YOU CALL FOR SERVICE

If the oven fails to operate:

- | | |
|--|--|
| <p>A) Check to ensure that the oven is plugged in securely. If it is not, remove the plug from the outlet, wait 10 seconds and plug it in again securely.</p> <p>B) Check for a blown circuit fuse or a tripped main circuit breaker. If these seem to be operating properly, test the outlet with another</p> | <p>appliance.</p> <p>C) Check to ensure that the control panel is programmed correctly and the timer is set.</p> <p>D) Check to ensure that the door is securely closed engaging the door safety lock system. Otherwise, the microwave energy will not flow into the oven.</p> |
|--|--|

IF NONE OF THE ABOVE RECTIFY THE SITUATION, THEN CONTACT A QUALIFIED TECHNICIAN. DO NOT TRY TO ADJUST OR REPAIR THE OVEN YOURSELF.

SPECIFICATIONS

Power consumption :	120V/60Hz, 1450 (Microwave)
	1050 (Grill)
	1450 (Convection)
Rated Microwave Output:	1000W
Operation Frequency:	2450MHz
Outside Dimensions:	300mm(H)×539mm(W)×485mm(D)
Oven Cavity Dimensions:	240mm(H)×376mm(W)×404mm(D)
Oven Capacity:	34Litres
Cooking Uniformity:	Turntable System
Net Weight:	Approx. 19.6kg

The above quoted need to be confirmed or updated.

PART NAMES

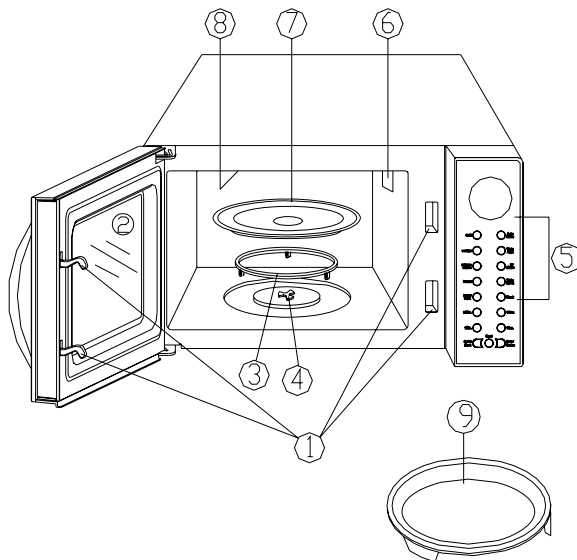

1. Door Safety Lock System
2. Oven Window
3. Roller Ring
4. Shaft
5. Control Panel
6. Oven Air Vent
7. Glass Tray
8. Grill Heater
9. Baking Plate

CONTROL PANEL

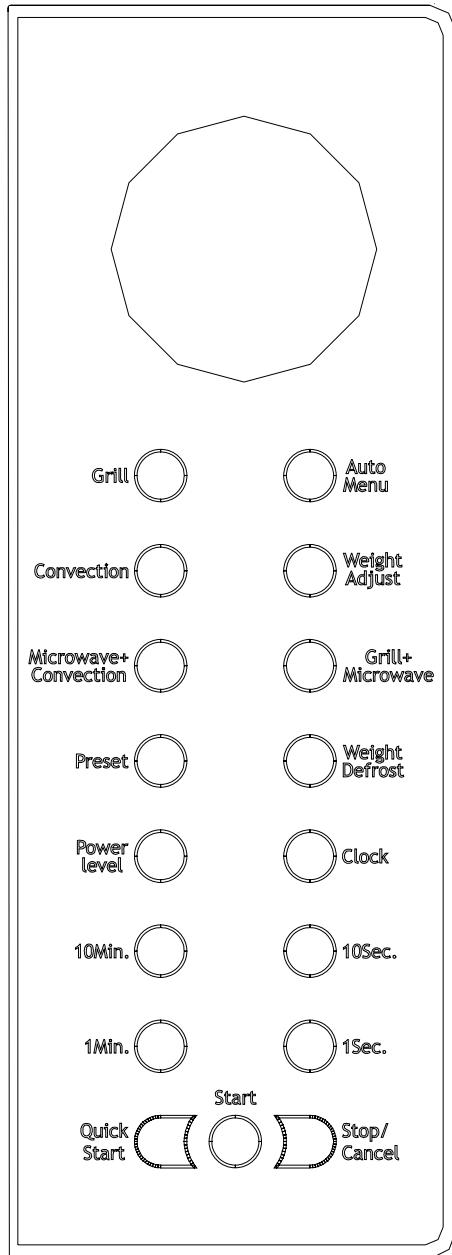

DISPLAY SCREEN

Cooking time, power, indicators and present time are displayed.

QUICK MINUTE BUTTONS

Touch to set clock, cooking time, enter food weight.

CLOCK

Used to set the clock.

PRESET

Used to set a delay start program.

POWER LEVEL

Press to select microwave power level.

WEIGHT DEFROST

Touch to defrost food by weight.

GRILL

Press to set a grill-cooking program.

AUTO MENU

Press for instant settings to cook popular food.

CONVECTION

Press to program convection cooking.

GRILL+MICROWAVE

Press to select one of two combination cooking settings.

MICROWAVE+CONVECTION

Press to select one of four combination cooking settings.

WEIGHT ADJUST

Touch to select food weight.

QUICK START

Touch to start the oven quickly at full power

START

Press to start cooking program.

STOP/CANCEL

Touch to stop cooking program or clear all previous settings before cooking starts.

HOW TO SET THE OVEN CONTROLS

BEEPS DURING OVEN SETTINGS

- ◆ ONE BEEP: Oven accepts the entry.
- ◆ TWO BEEPS: Oven does not accept the entry. Please check and try again.

SETTING THE CLOCK

For example: to set clock time 8: 08 (A.M or P.M).

1. Touch CLOCK button.
2. Touch number pads 10-MIN, 1-MIN, 10-SEC and 1-SEC to enter clock time.
3. Touch CLOCK button to confirm.

The clock works in 12-hour cycle. You can check the clock time when cooking is in progress by touching the CLOCK button.

MICROWAVE COOKING

Microwave cooking allows you to customize cooking power and time. First, you select a power level by pressing the POWER LEVEL button a number of times (see the table below). Then you set the cooking time (the longest cooking time is 99 minutes and 99 seconds) by using the number pads before pushing the START button.

Press POWER LEVEL button to select cooking power		
Press	Power	Description
Once	100%	High
twice	80%	Medium High
3 times	60%	Medium
4 times	40%	Medium Low
5 times	20%	Low
6 times	0%	0

Suppose you want to cook for 5 minutes at 60% power level.

1. Press POWER LEVEL a number of times to select power level.
2. Press number pads to enter cooking time until the correct cooking time (5:00) is displayed.
3. Press START button.

NOTE:

1. If you want to temporarily stop a cooking session, press STOP/CANCEL pad once

and then you can start the cooking again by pressing START; or press the button STOP/CANCEL twice to cancel the cooking program altogether.

2. After the cooking time ends, the system will beep several times and END is displayed. Before starting another cooking session, press STOP/CANCEL pad to clear the display and reset the system.
3. When Microwave cooking program is in progress, you can check the current power level by pressing POWER LEVEL button.

GRILL

Grill cooking is particularly useful for thin slices of meat, steaks, chops, kebabs, sausages and pieces of chicken. It is also suitable for hot sandwiches and au gratin dishes. The longest cooking time is 99 minutes and 99 seconds.

Suppose you want to program grill cooking for 12 minutes.

1. Make sure the system is reset by pressing STOP/CANCEL once.
2. Press GRILL button.
3. Use the number pads to enter cooking time.
4. Press START button.

NOTE:

Grill cooking power is set at full power level by the system.

CONVECTION

The longest cooking time is 9 hours and 99 minutes (9H: 99). During convection cooking, hot air is circulated throughout the oven cavity to brown and make crisp foods quickly and evenly. This oven can be programmed for ten different cooking temperatures (110°C~200°C).

To Cook with Convection

Suppose you want to cook at 180°C for 40 minutes.

1. Press CONVECTION button a number of times to set temperature.
2. Use the number pads to enter cooking time.
3. Press START button.

NOTE:

After time has elapsed beeps will sound and END appears in the display. Press STOP/CANCEL button or open door to clear END before starting another cooking function.

To Preheat and Cook with Convection

Your oven can be programmed to combine preheating and convection cooking operations.

Suppose you want to preheat to 170°C and then cook 35 minutes.

1. Press CONVECTION a number of times to set temperature.
2. Press START button.
3. Countdown stops until the oven reaches the programmed temperature. Open the door and place container of food at the center of the turntable.
4. Use the number pads to enter cooking time.
5. Press START button.

GRILL + MICROWAVE

This feature allows you to combine grill and microwave cooking on two different settings. The longest cooking time is 99 minutes and 99 seconds.

COMBINATION 1

30% time for microwave cooking, 70% for grill cooking. Use for fish or au gratin.

Suppose you want to set combination 1 cooking for 25 minutes.

1. Press GRILL+MICROWAVE button once.
2. Use the number pads to enter 25:00.
3. Press START button.

COMBINATION 2

55% time for microwave cooking, 45% for grill cooking. Use for pudding, omelets, potatoes and poultry.

Suppose you want to set combination 2 cooking for 12 minutes.

1. Press GRILL+MICROWAVE button twice.
2. Use the number pads to enter 12:00.
3. Press START button.

MICROWAVE +CONVECTION

This oven has four pre-programmed settings that make it easy to cook with both convection heat and microwave automatically. The longest cooking time is 99 minutes and 99 seconds.

Press MICROWAVE+CONVECTION button a number of times to program convection temperature:

	Temperature (°C)
COMB1	200
COMB2	170
COMB3	140
COMB4	110

Suppose you want to bake a cake for 24 minutes on COMB3.

1. Press MICROWAVE+CONVECTION button a number of times to select temperature.
2. Use the number pads to enter cooking time.
3. Press START button.

NOTE:

After time has elapsed several beeps will sound and END appears in the display. Press the button STOP/CANCEL or open door to clear END before starting another cooking function. You can check the convection temperature while cooking is in progress by pressing the MICROWAVE+CONVECTION button.

WEIGHT DEFROST

Automatically sets proper defrosting cycle once you have entered the weight of the food to be thawed. Maximum allowable weight for each category is shown below.

FOOD CATEGORY	MAXIMUM WEIGHT	DISPLAY
Meat	2300g	d1
Poultry	3500g	d2
Seafood	900g	d3

Suppose you want to defrost 600g food.

1. Touch WEIGHT DEFROST button several times to select food category.
2. Use number pads to enter food weight.
3. Touch START button.

NOTE:

During defrosting, the system will pause and sound beeps to remind you to open the oven

door and rearrange or turn over the food for better defrosting performance.

PRESET

Suppose you want to set the oven to start-up at a later time.

1. Set a cooking program.
2. Press PRESET pad once.
3. Use the number pads to enter preset time.
4. Touch PRESET pad to confirm.

NOTE: If you want to check preset time, press PRESET pad once, the time will be displayed for several seconds and during this time you can press STOP/CANCEL pad to cancel it.

Quick start, Weight defrost and Convection with preheat function can not be set with this feature.

MULTI-STAGE COOKING

Your oven can be programmed for up to 3

MENU COOK

For food or the following cooking mode, it is not necessary to program the duration and the cooking power. It is sufficient to indicate the type of food that you wish to cook as well as the weight of this food.

1. Press AUTO MENU repeatedly to select a food code.
2. Press WEIGHT ADJUST to select food weight.
3. Press START.

Auto Cook Code/Menu

Code	Food Category	Notes
1	Potato (230±10g/amount)	1. For cake and popcorn, there is only one choice. 2. For milk/coffee and potato, number of choice indicates amount but not weight. 3. For chicken, beeps can be heard during cooking to remind user to turn over the food for uniform cooking. 4. Voltage fluctuation and some other factors may cause food not done well, in such case, adjust the cooking time manually. 5. For Spaghetti, add boiling water before cooking.
2	Milk/coffee (200ml/cup)	
3	Popcorn(99g)	
4	Auto reheat	
5	Spaghetti	
6	Pizza	
7	Chicken	
8	Cake (475g)	

automatic cooking sequences.

Suppose you want to set the following cooking program.

Microwave cooking



Convection cooking (without preheat function)

1. Press POWER LEVEL button to set power level.
2. Use the number pads to enter cooking time.
3. Press CONVECTION to set temperature.
4. Use the number pads to enter convection cooking time.
5. Press START button.

NOTE: Quick start, Auto menu and Weight defrost can't be set in this mode. The preheat function can only be set in the last stage.

OTHER CONVENIENT FEATURES

QUICK START

Use this feature to program the oven to microwave food at 100% power conveniently.

Press QUICK START button in quick succession to set the cooking time.

The longest cooking time is 10 minutes. The oven will auto-start two seconds later. After time has elapsed beeps will sound and END appears in the display.

CHILD PROOF LOCK

The child proof lock prevents unsupervised operation by little children.

To set the child proof lock: Press STOP/CANCEL button for 3 seconds, then a beep will sound and the indicator light will turn on. In this state, all buttons are disabled.

To cancel the child proof lock: Press the button STOP/CANCEL for 3 seconds, then a beep will sound and the indicator light will turn off.

TO STOP THE OVEN WHILE THE OVEN IS OPERATING

1. Press STOP/CANCEL button.
You can restart the oven by pressing START pad.

Touch STOP/CANCEL to erase all instructions.

2. Open the door.

You can restart the oven by closing the door and pressing START pad.

NOTE:

Oven stops operating when door is opened.

OVERHEATING PROTECTION

During convection cooking, when the temperature of the cavity reaches over 300°C, the display will show E01 with buzzer sounding, press the STOP/CANCEL button the oven will be back to normal.

SENSOR MALFUNCTION PROTECTION

In case of short or open circuit, the system enters into malfunction protection. The display shows E03, buzzer will sound; press the STOP/CANCEL button the oven will be back to normal.

COOLING FEATURE

The electronical controlling system of the microwave oven has the feature of cooling. As for any cooking mode which cooking time above 2 minutes, after finishing cooking, the oven fan will work about 3 minutes automatically to cool the oven for prolonging the life of the oven.

CLEANING AND CARE

1. Turn off the oven and remove the power plug from the wall socket before cleaning.
2. Keep the inside of the oven clean. When food splatters or spilled liquids adhere to oven walls, wipe with a damp cloth. Mild detergent may be used if the oven gets very dirty. Avoid the use of spray and other harsh cleaners as they may stain, streak or dull the door surface.
3. The outside surfaces should be cleaned with a damp cloth. To prevent damage to the operating parts inside the oven, water should not be allowed to seep into the ventilation openings.
4. Wipe the door and window on both sides, the door seals and adjacent parts frequently with a damp cloth to remove any spills or spatters. Do not use abrasive cleaner.
5. Do not allow the control panel to become wet. Clean with a soft, damp cloth. When cleaning the control panel, leave oven door open to prevent oven from accidentally turning on.
6. If steam accumulates inside or around the outside of the oven door, wipe with a soft cloth. This may occur when the microwave oven is operated under high humidity condition. And it is normal.
7. It is occasionally necessary to remove the glass tray for cleaning. Wash the tray in warm sudsy water or in a dishwasher.
8. The roller ring and oven floor should be cleaned regularly to avoid excessive noise. Simply wipe the bottom surface of the oven with mild detergent. The roller ring may be washed in mild sudsy water or dishwasher. When removing the roller ring from cavity floor for cleaning, be sure to replace in the proper position.
9. Remove odors from your oven by combining a cup of water with the juice and skin of one lemon in a deep microwaveable bowl, microwave for 5 minutes. Wipe thoroughly and dry with a soft cloth.
10. When it becomes necessary to replace the oven light, please consult a dealer to have it replaced.
11. When cleaning surfaces of door and oven that comes together on closing the door, use only mild, nonabrasive soaps, or detergents applied with a sponge or soft cloth.

FCC Warning Statement

The Device complies with part 18 of the FCC rules, Operation is subject to the following conditions:
(1) This device may not cause harmful interference, and (2) this device must accept any interference received, including interference that may cause undesired operation

This device complies with Part 18 of the FCC Rules. This device may cause interference to radio and TV receivers. If interference is experienced, you can determine if this microwave oven is causing the interference by turning it off and on. To eliminate interference, move the receiver farther from the micro-wave oven or plug the receiver into a different AC outlet than the microwave oven.

SAVE THESE INSTRUCTIONS