

Microwave Oven

RED500JAH-PAHH0A

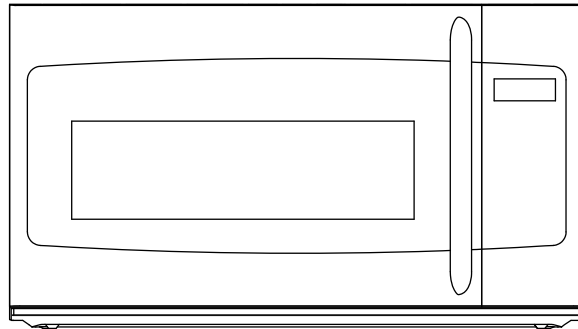

OWNER'S INSTRUCTIONS

Please read these instructions carefully before installing and operating the oven.

CONTENTS	1
PRECAUTIONS TO AVOID POSSIBLE EXPOSURE TO EXCESSIVE MICROWAVE ENERGY	2
IMPORTANT SAFETY INSTRUCTIONS	2
UNPACKING INSTRUCTIONS	5
GROUNDING INSTRUCTIONS	5
INFORMATION YOU NEED TO KNOW	6
SPECIFICATIONS	11
FEATURES DIAGRAM	11
CONTROL PANEL FEATURES	12
BASIC CONTROLS	13
TO SET THE CLOCK	13
MICROWAVE COOKING	13
PROGRAM COOKING	14
LIGHT CONTROL	14
VENT FAN CONTROL	14
VENT DELAY OFF	15
TURNTABLE	15
SPECIAL FEATURES	15
AUTO COOK	15
SENSOR COOK	15
WEIGHT DEFROST	17
TIME DEFROST	17
1LB DEFROST	18
OTHER CONVENIENT FEATURES	18
ADD 30 SEC	18
EXPRESS COOKIING	18
TIMER	18
ECO MODE	18
MY SETTI NG	18
CHILD LOCK	19
CLEAR AND CARE	20

- (a) Do not attempt to operate this oven with the door open since open-door operation can result in harmful exposure to microwave energy. It is important not to defeat or tamper with the safety interlocks.
- (b) Do not place any object between the oven front face and the door or allow soil or cleaner residue to accumulate on sealing surfaces.
- (c) Do not operate the oven if it is damaged. It is particularly important that the oven door close properly and that there is no damage to the:
 - ① Door (bent),
 - ② Hinges and latches (broken or loosened),
 - ③ Door seals and sealing surfaces.
- (d) The oven should not be adjusted or repaired by anyone except properly qualified service personnel.

When using electrical appliances, basic safety precautions should be followed, including the following:

WARNING - To reduce the risk of burns, electric shock, fire, and injury to persons or exposure to excessive microwave energy:

1. Read all instructions before using the appliance.
2. Read and follow the specific "PRECAUTIONS TO AVOID POSSIBLE EXPOSURE TO EXCESSIVE MICROWAVE ENERGY" on page 2.
3. This appliance must be grounded. Connect only to properly grounded outlet. See "GROUNDING INSTRUCTIONS" on page 5.
4. Install or locate this appliance only in accordance with the provided installation instructions.
5. Some products such as whole eggs and sealed containers -for example, closed glass jars- are able to explode and should not be heated in this oven.
6. Use this appliance only for its intended use as described in this manual. Do not use corrosive chemicals or vapors in this appliance. This type of oven is specifically designed to heat, cook, or dry food. It is not designed for industrial or laboratory use.
7. As with any appliance, close supervision is necessary when used by children.
8. To reduce the risk of fire in the oven cavity:
 - a) Do not overcook food. Carefully attend appliance when paper, plastic, or other combustible materials are placed inside the oven to facilitate cooking.
 - b) Remove wire twist-ties from paper or plastic bags before placing bag in oven.
 - c) If materials inside the oven should ignite, keep oven door closed, turn oven off, and disconnect the power cord or shut off power at the fuse or circuit breaker panel.
 - d) Do not use the cavity for storage purposes. Do not leave paper products, cooking utensils or

- food in the cavity when not in use.
9. Liquids, such as water, coffee, or tea can be overheated beyond the boiling point without appearing to be boiling due to surface tension of the liquid. Visible bubbling or boiling when the container is removed from the microwave oven is not always present. **THEIS COULD RESULT IN VERY HOT LIQUIDS SUDDENLY BOILING OVER WHEN A SPOON OR OTHER UTENSIL IS INSERTED INTO THE LIQUID.** To reduce the risk of injury to person:
 - a) Do not overheat the liquid.
 - b) Stir the liquid both before and halfway through heating it.
 - c) Do not use straight-sided containers with narrow necks.
 - d) After heating, allow the container to stand in the microwave oven for a short time before removing the container.
 - e) Use extreme care when inserting a spoon or other utensil into the container.
 10. Do not heat oil or fat for deep-frying. It is difficult to control the temperature of oil in microwave oven.
 11. Pierce foods with heavy skins such as potatoes, whole squash, apples and chestnuts before cooking.
 12. The contents of feeding bottles and baby jars should be stirred or shaken and the temperature should be checked before serving in order to avoid burns.
 13. Cooking utensils may become hot because of heat transferred from the heated food. Potholders may be needed to handle the utensil.
 14. Do not cover or block any openings on the appliance.
 15. Do not store or use this appliance outdoors. Do not use this product near water, for example, near a kitchen sink, in a wet basement, near a swimming pool, or similar locations.
 16. Do not operate this appliance if it has a damaged cord or a plug, if it is not working properly or if it has been damaged or dropped.
 17. Do not immerse cord or plug in water. Keep cord away from heated surface. Do not let cord hang over edge of table or counter.
 18. Use only thermometers, which are specifically designed for use in microwave ovens.
 19. Do not operate any heating or cooking appliance beneath this appliance.
 20. Be certain the glass tray and roller rings are in place when you operate the oven
 21. This appliance should be serviced only by qualified service personnel, contact nearest authorized service facility for examination, repair, or adjustment.
 22. When cleaning surfaces of door and oven that comes together on closing the door, use only mild, nonabrasive soaps, or detergents applied with a sponge or soft cloth.
 23. VENTILATING HOODS
 - 1) Clean Ventilating Hoods Frequently-Grease should not be allowed to accumulate on hood or filter.
 - 2) When flaming foods under the hood, turwhen cleaning the n the fan on.

24. Use care when cleaning the vent-hood filter. Corrosive cleaning agents, such as lye-based oven cleaners, may damage the filter.
25. Suitable for use above both gas and electric cooking equipment.
26. This equipment generates, uses and can radiate radio frequency energy and, if not installed and used in accordance with the instructions, may cause harmful interference to radio communications. However, there is no guarantee that interference will not occur in a particular installation. If this equipment does cause harmful interference to radio or television reception, which can be determined by turning the equipment off and on, the user is encouraged to try to correct the interference by one or more of the following measures:
 - Reorient or relocate the receiving antenna.
 - Increase the separation between the equipment and receiver.
 - Connect the equipment into an outlet on a circuit different from that to which the receiver is connected.
 - Consult the dealer or an experienced radio/TV technician for help

This device complies with part 18 of FCC rules.

SAVE THESE INSTRUCTIONS

Unpacking and Examining Your Oven

Carefully remove oven from carton. **SAVE THE CARTON AS IT MAY MAKE INSTALLATION EASIER.**

Remove:

1. All packing materials from inside the oven cavity; however, **DO NOT REMOVE THE WAVEGUIDE COVER**, which is located on the ceiling in the oven cavity. Check to see that there are Installation Instructions, Wall Template, Top Cabinet Template, bag of Installation Hardware, Charcoal Filter and Exhaust Damper Assembly. Read enclosures and **SAVE** the Owner's Instructions.
2. The feature sticker from the outside of the door, if there is one.

Check the oven for any damage, such as misaligned or bent door, damaged door seals and sealing surfaces, broken or loose door hinges and latches and dents inside the cavity or on the door. If there is any damage, do not operate the oven and contact your dealer.

See Installation Instruction for more details.

This appliance must be grounded. In the event of an electrical short circuit, grounding reduces the risk of electric shock by providing an escape wire for the electric current. This appliance is equipped with a cord having a grounding wire with a grounding plug. The plug must be plugged into an outlet that is properly installed and grounded.

WARNING--- Improper use of the grounding plug can result in a risk of electric shock.

Consult a qualified electrician or serviceman if the grounding instructions are not completely understood or if doubt exists as to whether the appliance is properly grounded. If it is necessary to use an extension cord, use only a 3-wire extension cord that has a 3-blade grounding plug, and a 3-slot receptacle that will accept the plug on the appliance. The marked rating of the extension cord shall be equal to or greater than the electrical rating of the appliance.

ELECTRICAL REQUIREMENTS

The electrical requirements are a 120 volt 60 Hz, AC only, 20 amp. It is recommended that a separate circuit serving only the oven be provided. The oven is equipped with a 3-prong grounding plug. It must be plugged into a wall receptacle that is properly installed and grounded.

Power Supply Cord

1. A short power supply cord is provided to reduce the risks resulting from becoming entangled in or tripping over a longer cord.
2. Longer cord sets or extension cords are available and may be used if care is exercised in their

use.

3. If long cord or extension cord is used:

- a) The marked electrical rating of the cord set or extension cord should be at least as great as the electrical rating of the appliance.
- b) The extension cord must be a grounding-type 3-wire cord, and The longer cord should be arranged so that it will not drape over the counter top or table top where it can be pulled on by children or tripped over unintentionally.

Notes:

If you have any questions about the grounding or electrical instructions, consult a qualified electrician or service person.

Neither Galanz nor the dealer can accept any liability for damage to the oven or personal injury resulting from failure to observe the electrical connection procedures.

RADIO OR TV INTERFERENCE

Should there be any interference caused by the microwave oven to your radio or TV, check that the microwave oven is on a different circuit, relocate the radio or TV as far away from the oven as feasible or check position and signal of receiving antenna.

ABOUT YOUR OVEN

NEVER use the oven without the turntable and support nor turn the turntable over so that a large dish could be placed in the oven. The turntable will turn both clockwise and anticlockwise.

The shelf gives you the option to reheat more than one dish of food at the same time. To reheat on 2 levels:



- Switch places after ½ the time.
- Make sure the shelf is positioned properly inside the microwave to prevent damage to the oven from arcing.
- Do not use a microwave browning dish on the shelf. The shelf could overheat.

- Do not use the oven with the shelf on the microwave floor. This could damage the microwave.

- Use pot holders when handling the shelf-it may be hot.

- Do not use the shelf when cooking popcorn.

ALWAYS have food in the oven when it is on to absorb the microwave energy.

When using the oven at power levels below 100%, you may hear the magnetron cycling on and off.

Condensation is a normal part of microwave cooking. Room humidity and the moisture in food will influence the amount of moisture that condenses in the oven. Generally,

covered foods will not cause as much condensation as uncovered ones. Ventilation openings must not be blocked.

In using recipes or package directions, check food a minute or two before the minimum time and add time accordingly.

ABOUT FOOD

FOOD	DO	DON'T
Eggs, sausages, fruits & vegetable	<ul style="list-style-type: none"> • Puncture egg yolks before cooking to prevent "explosion". • Pierce skins of potatoes, apples, squash, hot dogs and sausages so that steam escapes. 	<ul style="list-style-type: none"> • Cook egg in shells. • Reheat whole eggs.
Popcorn	<ul style="list-style-type: none"> • Use specially bagged popcorn for the microwave oven. • Listen while popping corn for the popping to slow to 1 or 2 seconds or use special Popcorn pad. 	<ul style="list-style-type: none"> • Pop popcorn in regular brown bags or glass bowls. • Exceed maximum time on popcorn package.
Baby food	<ul style="list-style-type: none"> • Transfer baby food to small dish and heat carefully, stirring often. Check temperature before serving. • Put nipples on bottles after heating and shake thoroughly. "Wrist" test before feeding. 	<ul style="list-style-type: none"> • Heat disposable bottles. • Heat bottles with nipples on. • Heat baby food in original jars.
General	<ul style="list-style-type: none"> • Cut baked goods with filling after heating to release steam and avoid burns. • Stir liquids briskly before and after heating to avoid "eruption". • Use deep bowl, when cooking liquids or cereals, to prevent boilovers. 	<ul style="list-style-type: none"> • Heat or cook in closed glass jars or airtight containers. • Can in the microwave as harmful bacteria may not be destroyed. • Deep fat fry. • Dry wood, gourds, herbs or wet papers.

ABOUT MICROWAVE COOKING

- Arrange food carefully. Place thickest areas towards outside of dish.
- Watch cooking time. Cook for the shortest amount of time indicated and add more as needed. Food severely overcooked can smoke or ignite.
- Cover foods while cooking. Check recipe or cookbook for suggestions: paper towels, wax paper, microwave plastic wrap or a lid. Covers prevent spattering and help foods to cook evenly.
- Shield with small flat pieces of aluminum foil any thin areas of meat or poultry to prevent overcooking before dense, thick areas are cooked thoroughly.
- Stir foods from outside to center of dish once or twice during cooking, if possible.
- Turn foods over once during microwaving to speed cooking of such foods as chicken and hamburgers. Large items like roasts must be turned over at least once.
- Rearrange foods such as meatballs halfway through cooking both from top to bottom and from the center of the dish to the outside.
- Add standing time. Remove food from oven and stir, if possible. Cover for standing time that allows the food to finish cooking without overcooking.
- Check for doneness. Look for signs

indicating that cooking temperatures have been reached.

- Center bottom of dish is very hot to the touch.
- Poultry thigh joints move easily.

TEMP	FOOD
160°F	...for fresh pork, ground meat, boneless white poultry, fish, seafood, egg dishes and frozen prepared food.
165°F	...for leftover, ready-to-reheat refrigerated, and deli and carry-out "fresh" food.
170°F	...white meat of poultry.
180°F	...dark meat of poultry.

Doneness signs include:

-Food steams throughout, not just at edge.

-Meat and poultry show no pinkness.

-Fish is opaque and flakes easily with a fork.

ABOUT SENSOR COOKING

- The proper containers and covers are essential for best sensor cooking.
- Always use microwave-safe containers and cover them with lids or vented plastic wrap. Never use tight sealing plastic containers — they can prevent steam from escaping and cause food to overcook.
- Be sure the outside of the cooking

containers and the inside of the microwave oven are dry before placing food in the oven. Beads of moisture turning into steam can mislead the sensor.

- Do not use this feature twice in succession on the same food portion — it may result in severely overcooked or burnt food.

ABOUT SAFETY

Check foods to see that they are cooked to the following recommended temperatures.

- To test for doneness, insert a meat thermometer in a thick or dense area away from fat or bone. **NEVER** leave the thermometer in the food during cooking, unless it is approved for microwave oven use.
- **ALWAYS** use potholders to prevent burns when handling utensils that are in contact with hot food. Enough heat from the food can transfer through utensils to cause skin burns.
- Avoid steam burns by directing steam away from the face and hands. Slowly lift

the farthest edge of a dish's covering and carefully open popcorn and oven cooking bags away from the face.

- Stay near the oven while it's in use and check cooking progress frequently so that there is no chance of overcooking food.
- **NEVER** use the cavity for storing cookbooks or other items.
- Select, store and handle food carefully to preserve its high quality and minimize the spread of food borne bacteria.
- Keep waveguide cover clean. Food residue can cause arcing and/or fires.

- Use care when removing items from the oven so that utensil, your clothes or

accessories do not touch the safety door latches.

ABOUT UTENSILS AND COVERINGS

It is not necessary to buy all new cookware. Many pieces already in your kitchen can be used successfully in your new microwave oven. Make sure the utensil does not touch the interior walls during cooking.

Use these utensils for safe microwave cooking and reheating

- glass ceramic
- heat-resistant glass
- microwave-safe plastics
- paper plates
- microwave-safe pottery, stoneware and porcelain
- browning dish

These items can be used for short time reheating of foods that have little fat or sugar in them:

- wood, straw, wicker

DO NOT USE

- metal pans and bake ware
- dishes with metallic trim
- non-heat-resistant glass
- non-microwave-safe plastic
- recycled paper bags
- food storage bags
- metal twist-ties

Should you wish to check if a dish is safe for microwaving, place the empty dish in the oven and microwave on HIGH for 30 seconds. A dish which becomes very hot should not be used.

The following coverings are ideal:

- Paper towels are good for covering foods

for reheating and absorbing fat while cooking bacon.

- Wax paper can be used for cooking and reheating.
- Plastic wrap that is specially marked for microwave use can be used for cooking and reheating. DO NOT allow plastic wrap to touch food. Vent so steam can escape.
- Lids that are microwave-safe are a good choice because heat is kept near the food to hasten cooking.
- Oven cooking bags are good for large meats or foods that need tenderizing. DO NOT use metal twist ties. Remember to slit bag so steam can escape.

How to use aluminum foil in your microwave oven:

- Small flat pieces of aluminum foil placed smoothly on the food can be used to shield areas that are either defrosting or cooking too quickly.
- Foil should not come closer than one inch to any surface of the oven.

ACCESSORIES There are many microwave accessories available for purchase. Evaluate carefully before you purchase so that they meet your needs. A microwave-safe thermometer will assist you in determining correct doneness and assure you that foods have been cooked to safe temperatures. Galanz is not responsible for any damage to the oven when accessories are used.

ABOUT CHILDREN AND THE MICROWAVE

Children below the age of 7 should use the microwave oven with a supervising person very near to them. Between the ages of 7 and 12, the supervising person should be in the same room.

The children must be able to reach the oven comfortably; if not, he/she should stand on a sturdy stool.

At no time should anyone be allowed to lean or swing on the oven door.
Children should be taught all safety precautions; use potholders, remove coverings carefully and pay special attention to packages that crisp food because they may be extra hot.
Don't assume that because a child has mastered one cooking skill he/she can cook everything.
Children need to learn that the microwave oven is not a toy.

Power Supply		120V/60Hz Single phase
Microwave	Power Consumption	1650W
	Output Power	1000W
	Frequency	2450MHz
Outside Dimensions		16 ⁷ / ₈ "(H) × 29 ⁷ / ₈ "(W) × 17 ¹⁵ / ₁₆ "(D)
Cavity Dimensions		10 ⁹ / ₁₆ "(H) × 21 ⁶ / ₁₆ "(W) × 14 ¹⁰ / ₁₆ "(D)
Oven Capacity		1.7 Cu.Ft.
Cooking Uniformity		Turntable /Stirrer Fan System
Weight		Approx. (net) 57.9lb / (gross) 64.6lb

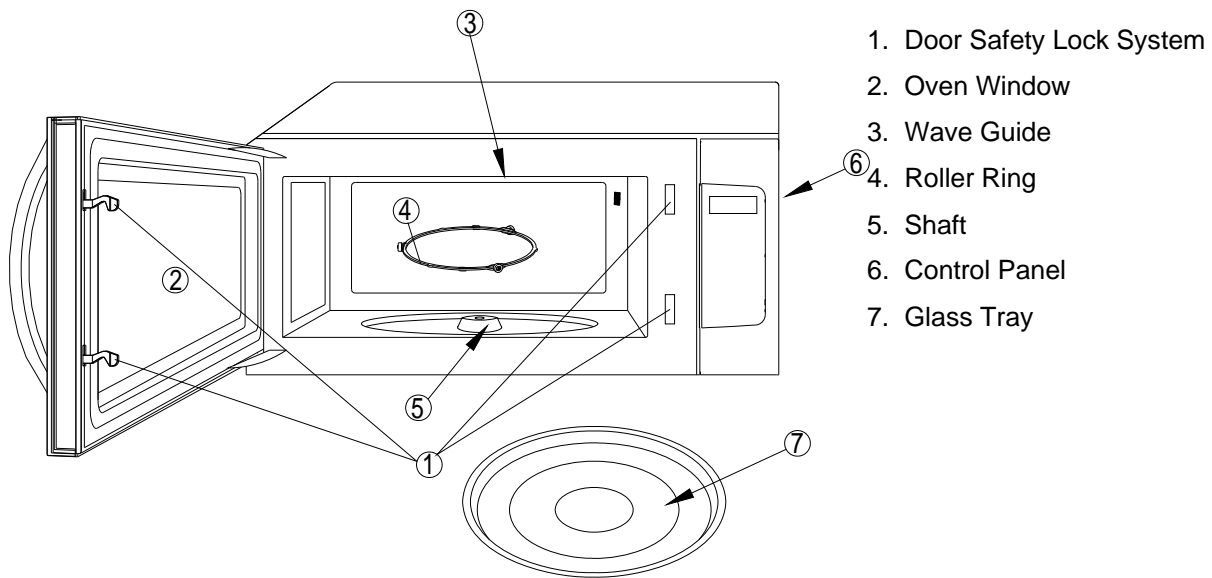

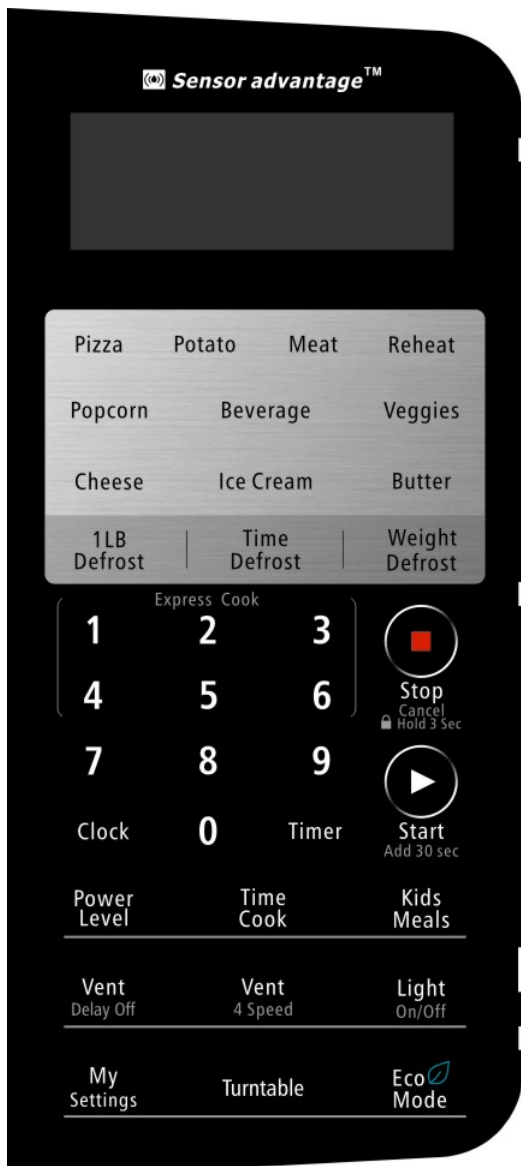

DISPLAY SCREEN

Cooking time, Lock indicator, timer, defrost sign and help information are displayed.

WEIGHT DEFROST/1LB DEFROST/TIME DEFROST

Easy settings to defrost program.

SENSOR MENU

Use to set sensor cook program.

AUTO MENU

Use to set auto cook program.

NUMBER PAD

Use to enter cook time or weight.

Use to set express cooking by pressing number pad (1-6).

POWER LEVEL

Use to set cooking power level.

TIME COOK

Use to set in microwave cooking or multi-stage cooking.

TIMER

Use to set the timer.

CLOCK

Use to set the oven clock.

LIGHT ON/OFF

Press to set the controls of the light outside the oven (light, dark and off mode).

VENT 4 SPEED

Fan motor control key.

VENT DELAY OFF

Use to set vent delay off program.

MY SETTING

Use to adjust the default Settings.

ECO mode

Use to set save power mode.

TURNTABLE

Touch to turn the turntable on or off.

STOP/CANCEL

Touch to stop the oven or reset the oven before setting a program.

START/ADD 30 SEC

Touch to start the oven; also use to start the oven quickly at full power.

The following pages contain more information for the use of these features.

- When cooking setting is interrupted for 1 minute, the system will back to the standby mode automatically.
- During cooking, if press STOP/CANCEL pad once or open the door, the program will be paused, then press START/ADD 30 SEC pad to resume, but if press STOP/CANCEL pad twice, the program will be canceled.
- After ending cooking, "END" will display and the system will sound beeps to remind user every one minutes until user press STOP/CANCEL pad or open the door.

Before operating your new microwave oven, please read and understand this operation manual completely.

TO SET THE CLOCK

This is a clock in 12 hour cycle. Suppose you want to enter 5:00 pm.

1. In standby mode, touch CLOCK pad once, "ENTER TIME OF DAY" will display.
2. Press number pads 5, 0, and 0.
3. Touch CLOCK to confirm. The display cycle displays "SELECT 1-AM, 2-PM".
4. Press number pads 2. "PM 5:00" will display.
5. Touch CLOCK to confirm.

NOTE: For initial power-up, "AM 12:00" will display. During cooking, you can press CLOCK pad to check the clock.

MICROWAVE COOKING

For microwave cooking you need to set cooking time and power level. The longest cooking time is 99 minutes and 99 seconds. There are 11 power levels for you to choose.

For example, you want to cook 10 minutes at 60% power level.

1. Press TIME COOK pad once and then use the number pads to enter cooking time. The longest cooking time you can set is 99 minutes and 99 seconds.
2. Touch POWER LEVEL pad once, the display will show "PL:Hi", and then use the number pad to select cooking power level(such as press number 6,"PL:60" display on the screen, after 5 seconds, the display cycle shows "PRESS START OR PRESS TIME COOK FOR THE NEXT STAGE COOKING TIME" to remind user).
3. Touch START/ADD 30 SEC pad to confirm.

NOTE: You can check the power level during cooking by pressing POWER LEVEL and change the power level by pressing number pad within this time.

Press number pads enter cooking power level.

PRESS NUMERBER PAD	POWER LEVEL(DISPLAY)
1,0	100%(PL:Hi)
9	90% (PL:90)
8	80% (PL:80)

7	70% (PL:70)
6	60% (PL:60)
5	50% (PL:50)
4	40% (PL:40)
3	30% (PL:30)
2	20% (PL:20)
1	10% (PL:10)
0	0% (PL:00)

PROGRAM COOKING

Your oven can be programmed for up to 2 automatic cooking sequences.

Suppose you want to set the following cooking program.

Microwave cooking



Microwave cooking

1. Input the first microwave cooking. Do not touch START/ADD 30SEC pad
2. Press TIME COOK pad once, and then input the second microwave cooking.
3. Touch START/ADD 30SEC to start.

NOTE: Only microwave cooking can be set in program cooking.

LIGHT CONTROL

This feature is designed for the convenience of doing things outside the oven. To turn on the light at the bottom of the oven, press LIGHT ON/OFF:

Press the button	Working Mode
Once	Light
Twice	Dark
3 times	Off

VENT FAN CONTROL

Your oven can be used as a range hood. When it is turned on, the fan motor starts filtering out smoke, odors, and grease generated from cooking.

In standby mode, the vent fan is manual control, continuous press "VENT/4 SPEED" can choose five cycle gears:

Press the button	Working Mode
Once	Strong Wind
Twice	High Wind
3 times	Medium wind
4 times	Low wind
5 times	Turn off

NOTE: If the vent fan is not opened, when you start microwave cooking program, the vent fan will keep this state, otherwise, when you start microwave cooking program, the Suction fan automatically work into a high wind gear. After 20 minutes later, you can manual cycle selection from high wind gear to strong wind.

VENT DELAY OFF

1. Under the vent fan open, press VENT DELAY OFF pad once, “ENTER DELAY OFF TIME” will display.
2. Use the number pads to enter the delay closing time. The longest time you can set is 99 minutes and 99 seconds.
3. Touch VENT DELAY OFF pad to confirm.

NOTE: Before the end of the countdown, you can press VENT DELAY OFF pad to check the countdown and can cancel the program by pressing STOP/CANCEL pad when the display shows the countdown. By the end of the countdown, all vent fans close.

TURNTABLE

For most cooking, the turntable should be on; however the turntable can be turned off so that it does not rotate for extra large dishes, such as the 13x9x2 inches glass utility casserole. Put the casserole on the turntable, press TURNTABLE button to turn the turntable on or off.

Sometimes the turntable may become too hot to touch. Be careful to touch the turntable.

NOTE: For Auto menu, Sensor menu and defrost cooking, the turntable cannot be turn off.



AUTO COOK

For auto cook it is not necessary to program the time and the cooking power. It is sufficient to indicate the type of food that you want to cook as well as the weight of this food.

1. Press the corresponding menu pad (Butter, Cheese and Ice cream) once.
2. Use number pad (1 ENTRY OR 2 ENTRY) select the amount.
3. Touch START/ADD 30 SEC pad.

SENSOR COOK

The sensor features detect the increasing humidity released during cooking. The oven automatically adjusts the cooking time to various types and amounts of food.

1. After cooking for a period of time, the system will detect whether there is error, if there is error, for example, the sensor short circuit or open circuit, the system will stop automatically with the display showing E-25, beeps sound until touch STOP/CANCEL pad.
2. If there is no error, the system will judge corresponding cooking time based on the steam generated by the food, after cooking for a period of time, the countdown will display on the screen.
3. If in the longest sensor time the oven cannot judge the cooking time according the steam

produced by food in the body, the cooking will auto-end and the display will show E-23.

Popcorn

1. Press POPCORN pad
2. Press START/ADD 30 SEC start cooking, “POPCORN” and “COOK” will display.

Potato

1. Press POTATO pad once.
2. Press START/ADD 30 SEC start cooking, “POTATO” and “COOK” will display.

Pizza

1. Press PIZZA pad once.
2. Press START/ADD 30 SEC to start cooking, “PIZZA” and “COOK” will display

Beverage

1. Press BEVERAGE pad.
2. Use one of the number from 1~3 to choose cup of beverage.
3. Press START/ADD 30SEC to start cooking.

Veggies

1. Press VEGGIES pad and then use numerical 1 to choose Fresh Veggies or numerical 2 to choose Frozen Veggies.
2. Touch START/ADD 30 SEC pad to start cooking.

Reheat

1. Press REHAET pad and then use numerical 1 to choose Dinner Plate (numerical 2 for Casserole、numerical 3 for Pasta).
2. Touch START/ADD 30 SEC pad to confirm.

Meat

1. Press the MEAT pad and then use numerical 1 to choose Pork (numerical 2 for Chops、numerical 3 for Ground Meat、numerical 4 for Chicken Piece).
2. Touch START/ADD 30SEC to confirm.

Kids meals

For hot dogs and frozen sandwiches:

1. Press the KIDS MEALS pad once.
2. Press numerical 2 to choose HOT DOGS or press numerical 4 to choose FROZEN SANDWICHES.
3. Press START/ADD 30 SEC pad to start cooking

For chicken nuggets and French fries:

1. Press the KIDS MEALS pad once.
2. Press numerical 1 to choose chicken nuggets or numerical 3 to choose French fries.
3. Press START/ADD 30 SEC to confirm.
4. Press number pad to choose the food weight
5. Press START/ADD 30 SEC pad to start cooking

SENSOR COOKING CHART

Food		Weight
Popcorn		3.0~3.5 oz or 99gr
Potato		1~3 entry (6~8oz/each or 170~230gr)
Pizza		5~16oz or 150~450gr
Beverage		1~3 cup(200ml/cup)
Veggies		5~24oz or 150~700gr
Reheat	Dinner Plate	5~24oz or 150~700gr
	Casserole	
	Pasta	
Meat	Pork	5~24oz or 150~700gr
	Chops	
	Ground Meat	
	Chicken Piece	
kids meals	chicken nuggets	4oz or 110gr
		8oz or 230gr
	hot dogs	1 serving
	French fries	4oz or 110gr
		8oz or 230gr
	frozen sandwiches	1 serving

WEIGHT DEFROST

WEIGHT DEFROST automatically defrosts foods. Press WEIGHT DEFROST, the display shows "ENTER WEIGHT oZ", then press number to select weight(defrost range: 1~96oz or 1~2715gr) . Suppose you want to defrost ground meat (2LB.5OZ.).

1. Touch WEIGHT DEFROST pad once,
2. Enter weight by touching the number pad.
3. Touch START/ADD 30 SEC pad.

NOTE: During defrost the oven will sound beeps and pause to remind user to turn the food over, after that, press START/ADD 30 SEC to resume.

TIME DEFROST

You can defrost any frozen food, either raw or previously cooked, by using TIME DEFROST. Suppose you want to defrost ground meat. Follow the steps under Time Defrosting.

1. Touch TIME DEFROST pad once, "ENTER DEFROST TIME" will display.
2. Enter time by touching the number pad.(Longest time is 99:99)
3. Touch START/ADD 30 SEC pad.

NOTE: During defrost the oven will sound beeps and pause to remind user to turn the food over, after that, press START/ADD 30 SEC to resume.

Please remember to place the food on a microwave-safe dish not in a plastic container.

1LB DEFROST

In standby, press 1LB DEFROST pad once, and then press START/ADD 30 SEC to start defrosting.

NOTE: During defrosting, the oven will pause and beep to remind you to open the door and turn food over to obtain better cooking effect and then touch START/ADD 30 SEC pad to resume remaining time.



ADD 30 SEC

In standby mode, simply touch the START/ADD 30 SEC pad once and the oven will start cooking immediately at 100% power level and press START/ADD 30 SEC pad repeatedly can add cook time.

During cooking (except sensor menu, sensor cook and defrost), you can add the cooking time by touching START/ADD 30 SEC pad and each press overtime 30 seconds up to 99 minutes and 99 seconds.

EXPRESS COOKING

In standby mode, press the number pad (from 1 to 6) to enter cooking time (between 1 minute and 6 minutes), and then press START/ADD 30 SEC pad, the oven will start cooking at 100% high power level.

TIMER

The longest time you can enter is 99 minutes and 99 seconds.

1. In standby mode, touch TIMER pad once, "ENTER KITCHEN TIMER" will display.
2. Use the number pads to enter time.
3. Touch START/ADD 30 SEC pad.

NOTE: During the cooking process, you cannot set the TIMER. When it reaches the end of the set time, the buzzer will beep to remind you.

ECO MODE

In standby, press ECO MODE pad. Oven turn to the lowest power consumption mode and screen is blank until you press any pad or open the door.

MY SETTING

MY SETTINGS provides hints for 3 features which make it easy to use the oven because specific instructions are provided in the Interactive Display.

In standby mode, press MY SETTINGS pad once, the screen will cycle show "1-WEIGHT MODE, 2-SOUND ON/OFF, 3-DAYLIGHT SAVING TIME ON/OFF", and then according to the

corresponding numbers (1~3) to select the corresponding Settings.

NOTE: The default startup state: SOUND to On, WEIGHT UNIT for oz, DAYLIGHT SAVE TIME to Off.

WEIGHT UNIT SETTING HINT

1. In standby, press MY SETTINGS once and then press number pad 1 to enter the weight unit setting.
2. You can press number pad 1 to select “oz” for weight unit, or number pad 2 to select “gr” for weight unit.
3. Press MY SETTINGS to confirm you choose.

SOUND ON/OFF

1. In standby, press MY SETTINGS once and then press number pad 2 to enter the Key-touch beep setting.
2. You can press number pad 1 to select sound on. If you want to have the oven operates with no audible signals, press number pad 2 to select sound off.
3. Press MY SETTINGS to confirm.

DAYLIGHT SAVING TIME ON/OFF

1. In standby, press MY SETTINGS once and then press number pad 3 to enter the Daylight Saving Time setting. The display will show “CURRENT STATE IS OFF, 1-ON,2-SKIP” or “CURRENT STATE IS ON, 1-OFF,2-SKIP”.
2. When the display show “CURRENT STATE IS OFF, 1-ON,2-SKIP”, press number 1 to set Daylight Saving Time, but if the display show “CURRENT STATE IS ON, 1-OFF,2-SKIP” , press number pads 1 will cancel Daylight Saving Time setting or presses numerical 2 skip the current setting.
3. Press MY SETTINGS to confirm.

NOTE: When you set Daylight Saving Time, the clock time will ahead of one hour.

CHILD LOCK

The child lock prevents unsupervised operation by children and this program only works in standby mode

To set, in standby mode, press and hold STOP/CANCEL for 3 seconds. LOCK is indicated on the display.

To cancel, press and hold STOP/CANCEL for 3 seconds. LOCK indication disappears.

Exterior

The outside surface is precoated steel and plastic. Clean the outside with mild soap and water; rinse and dry with a soft cloth. Do not use any type of household or abrasive cleaner.

Door

Wipe the window on both sides with a damp cloth to remove any spills or splatters. Metal parts will be easier to maintain if wiped frequently with a damp cloth. Avoid the use of spray and other harsh cleaners as they may stain, streak or dull the door surface.

Touch Control Panel

Care should be taken in cleaning the touch control panel. If the control panel becomes soiled, open the oven door before cleaning. Wipe the panel with a cloth dampened slightly with water only. Dry with a soft cloth. Do not scrub or use any sort of chemical cleaners. Close door and touch STOP/CANCEL.

Interior

Cleaning is easy because little heat is generated to the interior surfaces; therefore, there is no baking and setting of spills or splattering. To clean the interior surfaces, wipe with a soft cloth and warm water. **DO NOT USE ABRASIVE OR HARSH CLEANERS OR SCOURING PADS.** For heavier soil, use baking soda or a mild soap; rinse thoroughly with hot water.

Waveguide Cover

The waveguide cover is located on the ceiling in the oven cavity. It is made from mica so requires special care. Keep the waveguide cover clean to assure good oven performance. Carefully wipe with a damp cloth any food splatters from the surface of the cover immediately after they occur. Built-up splashes

may overheat and cause smoke or possibly catch fire. **DO NOT REMOVE THE WAVEGUIDE COVER.**

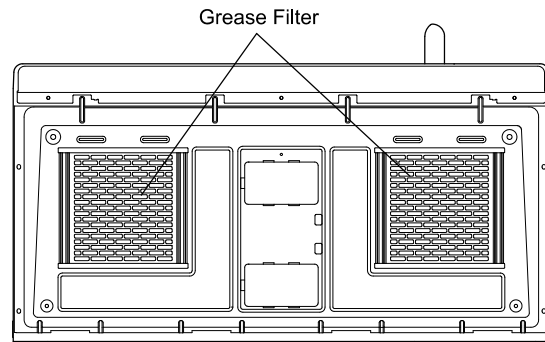

Fan

The fan will automatically start when heat rises from range surface units or burners. This protects the microwave oven from excessive temperature rise. The fan will stay on until the temperature decrease. It cannot be turned off manually during this time.

For other uses, select either HI or LO speed.

Odor Removal

Occasionally, a cooking odor may remain in the oven. To remove, combine 1 cup water, grated peel and juice of 1 lemon and several whole cloves in a 2-cup glass measuring cup. Boil for several minutes using 100% power. Allow to set in oven until cool. Wipe interior with a soft cloth.

Turntable/Turntable Support

The turntable and turntable support can be removed for easy cleaning. Wash them in mild, sudsy water; for stubborn stains use a mild cleanser and non-abrasive scouring sponge as described above. They are also dishwasher-proof. Use upper rack of dishwasher. The turntable motor shaft is not sealed, so excess water or spills should be wiped up immediately.

Grease Filters

Filters should be cleaned at least once a month. Never operate the fan or oven without the filters in place.

1. Pull down slightly on the tab toward the front of the oven and remove the filter. Repeat for the other filter.
2. Soak the filter in a sink or dish pan filled with hot water and detergent. DO NOT use ammonia or other alkali; they will react with the filter material and darken it.
3. Agitate and scrub with a brush to remove embedded dirt.
4. Rinse thoroughly and shake dry.
5. Replace by fitting the filter back into the opening.

Light

1. To replace light bulbs, first disconnect power to the oven at the circuit breaker panel or by unplugging.
2. To release cover, remove the screw on the light cover. (See illustration.)
3. DO NOT USE A BULB LARGER THAN 30 WATTS.
4. Close light cover and secure with screw removed in step 2.

CAUTION: Light cover may become very hot. Do not touch glass when light is on.

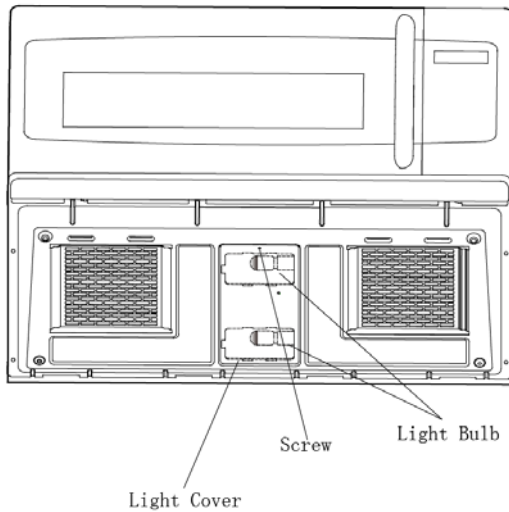

Charcoal Filter

Charcoal filter is used for nonvented, recirculated installation. The filter should be changed every 6 to 12 months depending on use.

1. Disconnect power to the oven at the circuit breaker panel or by unplugging.
2. Remove the louver mounting screw from the top center of the louver and push down carefully on the tab at each end of the louver to disengage it. (See illustration.)
3. Pull the louver away from the unit.
4. Change the charcoal filter.
5. Carefully push the louver back into place and replace the screw remove in step 2.

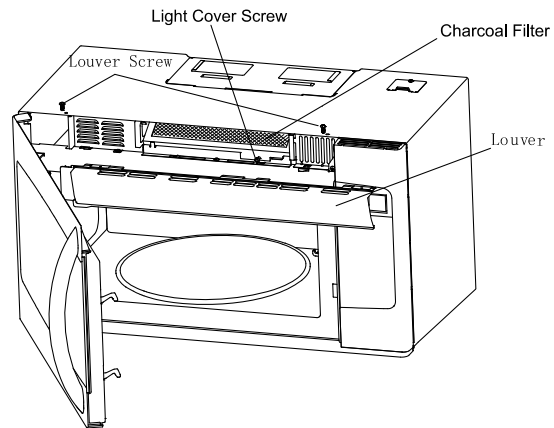

Oven Light

Remove the louver per instructions 1~3 above and charcoal filter, if used.

1. Open light cover located behind filter mounting by carefully pulling up on the front edge.

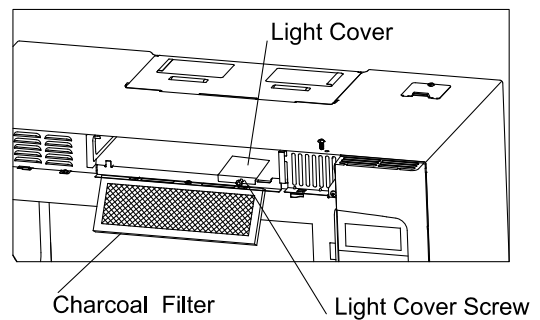

2. DO NOT USE A BULB LARGER THAN 30

WATTS.

3. Replace the oven light cover by carefully pushing into place. Replace the charcoal

filter, if used. Push the louver back into place and replace the louver mounting screw.