

Model: P110N28AP-SL

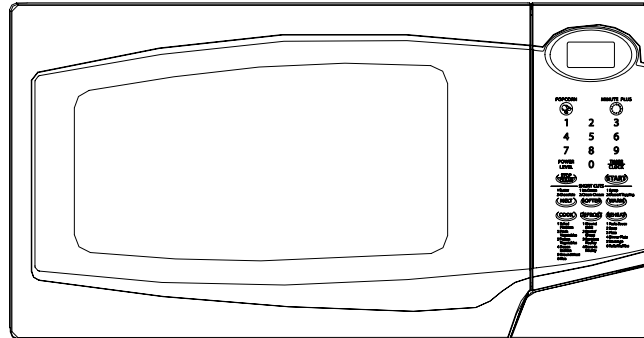

Microwave Oven

User's manual

Please read these instructions carefully before installing and operating the oven.

Record in the space below the SERIAL NO. found on the nameplate on your oven and retain this information for future reference.

SERIAL NO.

Please save sales receipt for warranty.

This equipment generates, uses and can radiate radio frequency energy and, if not installed and used in accordance with the instructions, may cause harmful interference to radio communications. However, there is no guarantee that interference will not occur in a particular installation. If this equipment does cause harmful interference to radio or television reception, which can be determined by turning the equipment off and on, the user is encouraged to try to correct the interference by one or more of the following measures:

- *Reorient or relocate the receiving antenna.*
- *Increase the separation between the equipment and receiver.*
- *Connect the equipment into an outlet on a circuit different from that to which the receiver is connected.*
- *Consult the dealer or an experienced radio/TV technician for help*

# PRECAUTIONS TO AVOID POSSIBLE EXPOSURE TO EXCESSIVE MICROWAVE ENERGY

1. Do not attempt to operate this oven with the door-open since open-door operation can result in harmful exposure to microwave energy. It is important not to defeat or tamper with the safety interlocks.
2. Do not place any object between the oven front face and the door or allow soil or cleaner residue to accumulate on sealing surfaces.
3. Do not operate the oven if it is damaged. It is particularly important that the oven door close properly and that there is no damage to the:
  - a. Door (bent),
  - b. Hinges and latches (broken or loosened),
  - c. Door seals and sealing surfaces.
4. The oven should not be adjusted or repaired by anyone except properly qualified service personnel.

## CONTENT

PRECAUTIONS TO AVOID POSSIBLE EXPOSURE TO EXCESSIVE MICROWAVE ENERGY .....	1
IMPORTANT SAFETY INSTRUCTIONS.....	2
INSTALLATION GUIDE .....	4
GROUNDING INSTRUCTIONS.....	4
UTENSILS GUIDE .....	5
COOKING TECHNIQUES.....	6
SPECIFICATIONS.....	7
PART NAMES .....	8
CONTROL PANEL .....	9
HOW TO SET THE OVEN CONTROLS .....	10
Setting the clock .....	10
Microwave cooking.....	10
Timer .....	10
Defrost.....	11
Multi-stage Cooking.....	11
Minute Plus.....	11
Child Lock.....	12
Menu Cook.....	12
CLEANING AND CARE.....	14

# IMPORTANT SAFETY INSTRUCTIONS

When using electrical appliances, basic safety precautions should be followed, including the following:

**WARNING** - To reduce the risk of burns, electric shock, fire, injury to persons or exposure to excessive microwave energy:

1. Read all instructions before using the appliance.
2. Read and follow the specific "PRECAUTIONS TO AVOID POSSIBLE EXPOSURE TO EXCESSIVE MICROWAVE ENERGY" on page 1.
3. This appliance must be grounded. Connect only to properly grounded outlet. See "GROUNDING INSTRUCTIONS " on page 4.
4. Install or locate this appliance only in accordance with the provided installation instructions.
5. Some products such as whole eggs and sealed containers -for example, closed glass jars- are able to explode and should not be heated in this oven.
6. Use this appliance only for its intended use as described in this manual. Do not use corrosive chemicals or vapors in this appliance. This type of oven is specifically designed to heat, cook, or dry food. It is not designed for industrial or laboratory use.
7. As with any appliance, close supervision is necessary when used by children.
8. To reduce the risk of fire in the oven cavity:
  - a. Do not overcook food. Carefully attend appliance when paper, plastic, or other combustible materials are placed inside the oven to facilitate cooking.
  - b. Remove wire twist-ties from paper or plastic bags before placing bag in oven.
  - c. If materials inside the oven should ignite, keep oven door closed, turn oven off, and disconnect the power cord or shut off power at the fuse or circuit breaker panel.
  - d. Do not use the cavity for storage purposes. Do not leave paper products, cooking utensils or food in the cavity when not in use.
9. Liquids, such as water, coffee, or tea are able to be overheated beyond the boiling point without appearing to be boiling due to surface tension of the liquid. Visible bubbling or boiling when the container is removed from the microwave oven is not always present. **THIS COULD RESULT IN VERY HOT LIQUIDS SUDDENLY BOILING OVER WHEN THE CONTAINER IS DISTURBED OR A UTENSIL IS INSERTED INTO THE LIQUID.** To reduce the risk of injury to person:
  - a. Do not overheat the liquid.
  - b. Stir the liquid both before and halfway through heating it.
  - c. Do not use straight-sided containers with narrow necks.
  - d. After heating, allow the container to stand in the microwave oven for a short time before removing the container.
  - e. Use extreme care when inserting a spoon or other utensil into the container.
10. Do not heat oil or fat for deep-frying. It is difficult to control the temperature of oil in microwave oven.
11. Pierce foods with heavy skins such as potatoes, whole squash, apples and chestnuts before cooking.
12. The contents of feeding bottles and baby jars should be stirred or shaken and the temperature should be checked before serving in order to avoid burns.
13. Cooking utensils may become hot because of heat transferred from the heated food. Potholders may be needed to handle the utensil.
14. Do not cover or block any openings on the appliance.

**2**

**SAVE THESE INSTRUCTIONS**

15. Do not store or use this appliance outdoors. Do not use this product near water, for example, near a kitchen sink, in a wet basement, near a swimming pool, or similar locations.
16. Do not operate this appliance if it has a damaged cord or a plug, if it is not working properly or if it has been damaged or dropped.
17. Do not immerse cord or plug in water. Keep cord away from heated surface. Do not let cord hang over edge of table or counter.
18. Use only thermometers, which are specifically designed for use in microwave ovens.
19. Do not operate any heating or cooking appliance beneath this appliance.
20. Be certain the glass tray and roller rings are in place when you operate the oven.
21. This appliance should be serviced only by qualified service personnel, contact nearest authorized service facility for examination, repair, or adjustment.
22. When cleaning surfaces of door and oven that comes together on closing the door, use only mild, nonabrasive soaps, or detergents applied with a sponge or soft cloth.

**3**

**SAVE THESE INSTRUCTIONS**

# INSTALLATION GUIDE

1. Make sure that all the packing materials are removed from the inside of the door.
2. Check the oven for any damage, such as misaligned or bent door, damaged door seals and sealing surface, broken or loose door hinges and latches and dents inside the cavity or on the door. If there is any damage, do not operate the oven but contact qualified service personnel.
3. This microwave oven must be placed on a flat, stable surface to hold its weight and the heaviest food likely to be cooked in the oven.
4. Do not place the oven where heat, moisture, or high humidity are generated, or near combustible materials.
5. For correct operation, the oven must have sufficient airflow. Allow 20cm of space above the oven, 10cm at back and 5cm at both sides. Do not cover or block any openings on the appliance. Do not remove feet on which oven stands.
6. Do not operate the oven without glass tray, roller support, and shaft in their proper positions.
7. Make sure that the power supply cord is undamaged and does not run under the oven or over any hot or sharp surface.
8. The socket must be readily accessible so that it can be easily unplugged in an emergency.

## GROUNDING INSTRUCTIONS

This appliance must be grounded. In the event of an electrical short circuit, grounding reduces risk of electric shock by providing an escape wire for the electric current.

**WARNING** Improper use of the grounding plug can result in a risk of electric shock.

Consult a qualified electrician or serviceman if the grounding instructions are not completely understood, or if doubt exists as to whether the appliance is properly grounded, and either:

- 1) If it is necessary to use an extension cord, use only a 3-wire extension cord that has a 3-blade grounding plug and a 3-slot receptacle that will accept the plug on the appliance. The marked rating of the extension cord shall be equal to or greater than the electrical rating of the appliance, or
- 2) Do not use an extension cord. If the power supply cord is too short, have a qualified electrician or serviceman install an outlet near the appliance.

### ELECTRICAL REQUIREMENTS

The electrical requirements are a 120 volt 60 Hz, AC only, 20 amp. It is recommended that a separate circuit serving only the oven be provided. The oven is equipped with a 3-prong grounding plug. It must be plugged into a wall receptacle that is properly installed and grounded.

#### **Power Supply Cord**

1. A short power supply cord is provided to reduce the risks resulting from becoming entangled in or tripping over a longer cord.
2. Longer cord sets or extension cords are available and may be used if care is exercised in their use.

3. If long cord or extension cord is used:

- a) The marked electrical rating of the cord set or extension cord should be at least as great as the electrical rating of the appliance.
- b) The extension cord must be a grounding-type 3-wire cord, and The longer cord should be arranged so that it will not drape over the counter top or table top where it can be pulled on by children or tripped over unintentionally.

Notes:

If you have any questions about the grounding or electrical instructions, consult a qualified electrician or service person.

Neither Galanz nor the dealer can accept any liability for damage to the oven or personal injury resulting from failure to observe the electrical connection procedures.

### **Radio or TV Interference**

Should there be any interference caused by the microwave oven to your radio or TV, check that the microwave oven is on a different circuit, relocated the radio or TV as far away from the oven as feasible or check position and signal of receiving antenna.

This section lists which utensils can be used in the microwave, which ones have limited use for short periods, and which ones should not be used in the microwave.

## **UTENSILS GUIDE**

### **RECOMMENDED**

**Microwave browning dish** — Use to brown the exterior of small items such as steaks, chops, or pancakes. Follow the directions provided with your browning dish.

**Microwaveable plastic wrap** — Use to retain steam. Leave a small opening for some steam to escape and avoid placing it directly on the food.

**Paper towels and napkins** — Use for short-term heating and covering; these absorb excess moisture and prevent spattering. Do not use recycled paper towels, which may contain metal and could ignite.

**Glass and glass-ceramic bowls and dishes** — Use for heating or cooking.

**Paper plates and cups** — Use for short-term heating at low temperatures. Do not use recycled paper, which may contain metal and could ignite.

**Wax paper** — Use as a cover to prevent spattering.

**Thermometers** — Use only those labeled "Microwave Safe" and follow all directions. Check the food in several places. Conventional thermometers may be used on microwave food once the food has been removed from the oven.

### **LIMITED USE**

**Aluminum foil** — Use narrow strips of foil to prevent overcooking of exposed areas. Using too much foil can damage your oven, so be careful. You should keep distance of 1 inch (2.54cm) between aluminum foil and cavity.

**Ceramic, porcelain, and stoneware**— Use these if they are labeled "Microwave Safe". If they are not labeled, test them to make sure they can be used safely.

**Plastic** — Use only if labeled "Microwave Safe". Other plastics can melt.

## Not Recommended

**Glass jars and bottles** — Regular glass is too thin to be used in a microwave. It can shatter and cause damage and injury.

**Paper bags** — These are a fire hazard, except for popcorn bags that are designed for microwave use.

**Styrofoam plates and cups** — These can melt and leave an unhealthy residue on food.

**Plastic storage and food containers** — Containers such as margarine tubs can melt in the microwave.

**Metal utensils** — These can damage your oven. Remove all metal before cooking.

### Note:

Should you wish to check if a dish is safe for microwaving, place the empty dish in the oven and microwave on HIGH for 30 seconds. A dish which becomes very hot should not be used.

# COOKING TECHNIQUES

Your microwave makes cooking easier than conventional cooking, provided you keep these considerations in mind:

## STIRRING

---

Stir foods such as casseroles and vegetables while cooking to distribute heat evenly. Food at the outside of the dish absorbs more energy and heats more quickly, so stir from the outside to the center. The oven will turn off when you open the door to stir your food.

## ARRANGEMENT

---

Arrange unevenly shaped foods, such as chicken pieces or chops, with the thicker, meatier parts toward the outside of the turntable where they receive more microwave energy. To prevent overcooking, place delicate areas, such as asparagus tips, toward the center of the turntable.

## SHIELDING

---

Shield food with narrow strips of aluminum foil to prevent overcooking. Areas that need shielding include poultry wing tips, the ends of poultry legs, and corners of square baking dishes. Use only small amounts of aluminum foil. Larger amounts can damage your oven.

## TURNING

---

Turn foods over midway through cooking to expose all parts to microwave energy. This is especially important with large foods such as roasts.

## STANDING

---

Foods cooked in the microwave build up internal heat and continue to cook for a few minutes after heating stops. Let foods stand to complete cooking, especially foods such as cakes and whole vegetables. Roasts need this time to complete cooking in the center without overcooking the outer areas. All liquids, such as soup or hot chocolate, should be shaken or stirred when cooking is complete. Let liquids stand a moment before serving. When heating baby food, stir well at removal and test the temperature before serving.

## ADDING MOISTURE

---

Microwave energy is attracted to water molecules. Food that is uneven in moisture content should be covered or allowed to stand so that the heat disperses evenly. Add a small amount of water to dry food to help it cook

# SPECIFICATIONS

<b>Power Consumption:</b>	<b>120V~60Hz, 1600W (Microwave)</b>
<b>Output:</b>	<b>1100W</b>
<b>Operation Frequency:</b>	<b>2450MHz</b>
<b>Outside Dimensions(H×W×D):</b>	<b>11.8×21.3×15.8 in.</b>
<b>Oven Cavity Dimensions(H×W×D):</b>	<b>8.7×13.9×14.1 in.</b>
<b>Oven Capacity:</b>	<b>1.0 cu.ft</b>
<b>Cooking Uniformity:</b>	<b>Turntable System</b>
<b>Net Weight:</b>	<b>Approx. 35.3 lb.</b>



# PART NAMES

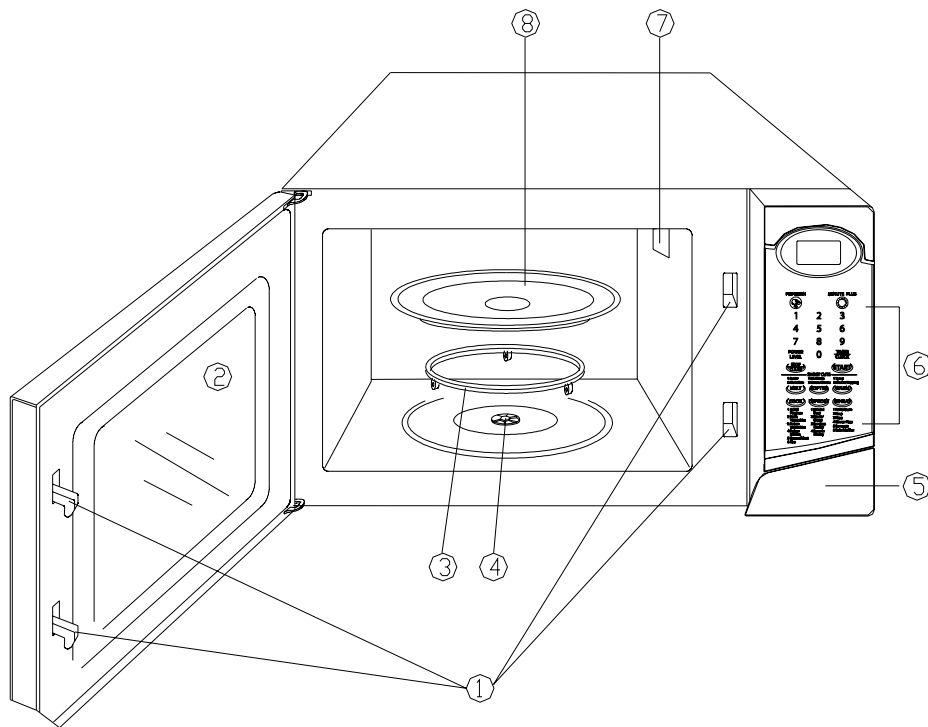

1. Door Safety Lock System

2. Oven Window

3. Roller ring

4. Shaft

5. Door Release Button

6. Control Panel

7. Wave Guide

(Please do not remove the mica plate covering the wave guide)

8. Glass tray

# CONTROL PANEL

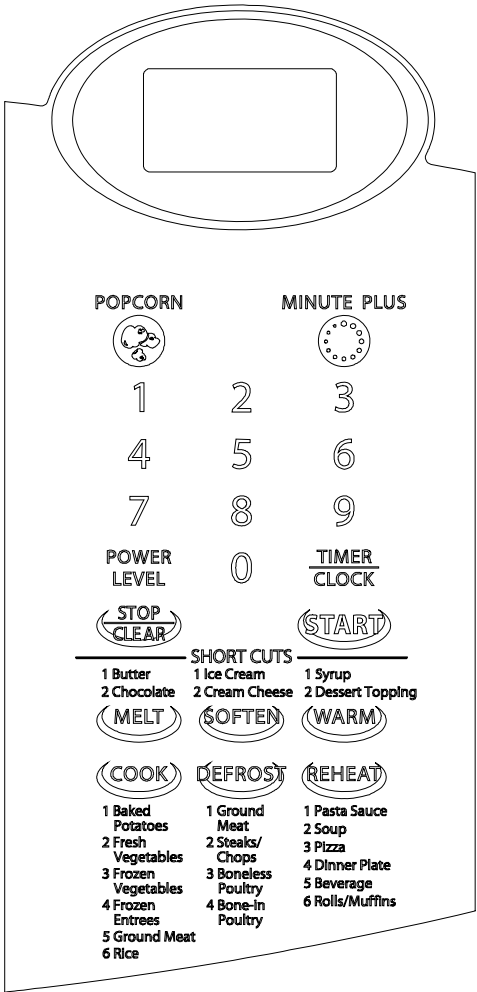

**DISPLAY WINDOW**

Use to indicate clock, cooking time, etc.

**MINUTE PLUS**

Press to set the oven to start cooking quickly and to increase the cooking time.

**NUMBER PADS**

Press to set clock, cooking time or enter food weight.

**POWER LEVEL**

Press to select microwave power level.

**TIMER/CLOCK**

Press to set the timer function and to set the oven clock.

**STOP/CLEAR**

Press to clear entry before setting a cooking program  
 Press once to temporarily stop cooking or twice to cancel cooking.

Press and hold to set child lock.

**START**

Press to start cooking program.

**QUICK COOK BUTTONS:**

Instant settings to cook popular foods.  
 POPCORN, MELT, SOFTEN, WARM, COOK, DEFROST, REHEAT

# HOW TO SET THE OVEN CONTROLS

Each time a button is touched, a beep will sound to acknowledge the touch.

When the oven is first plugged in, press STOP/CLEAR to enter into the standby mode.

## SETTING THE CLOCK

To enter the digital clock time, press the TIMER/CLOCK pad once and then press the number pads to set the time of day.

For example: to set the time of 6: 35.

1. Press TIMER/CLOCK pad once.
2. Touch number pad to enter clock time.
3. Press TIMER/CLOCK pad again to confirm.

NOTE: This is a 12 hour clock, you can see the time during cooking by pressing TIMER/CLOCK pad.

## MICROWAVE COOKING

To cook with microwave, time and power level should be set. The longest cooking time to be set by pressing the number pads is 99 min. 99 sec.

By pressing the POWER LEVEL pad a number of times, you are selecting one of the following microwave power levels:

Press	Power Level	Display
Once	100%	P-HI
Twice	90%	P-90
Thrice	80%	P-80
4 times	70%	P-70
5 times	60%	P-60
6 times	50%	P-50
7 times	40%	P-40
8 times	30%	P-30
9 times	20%	P-20
10 times	10%	P-10
11 times	0%	P-0

Suppose you want to cook for 5 minutes at 60% of microwave power.

1. Press POWER LEVEL pad to set 60%.
2. Touch number pad to enter desired cooking time.
3. Press START pad.

## TIMER

The oven could used to count the cooking time or others.

Suppose you want to set 30 minutes timer.

1. In standby mode, press the number pads to enter 30 minutes.
2. Press TIMER/CLOCK to confirm.

NOTE: You can press STOP/CLEAR once to cancel this function.

## DEFROST

---

The oven allows the defrosting of Ground Meat, Steaks/Chops, Boneless Poultry and Bone-in Poultry. The time and the defrosting power are adjusted automatically once the weight of food is programmed.

The maximum allowable weight for each category is shown below.

NUMBER PAD	FOOD CATEGORY	MAXIMUM WEIGHT
1	Ground Meat	2 lb
2	Steaks/Chops	3 lb
3	Boneless Poultry	1lb 8 oz
4	Bone-in Poultry	3lb

FOR EXAMPLE: Suppose you want to defrost 1 lb of Ground Meat.

1. Place the meat to be defrosted into the oven.
2. Press DEFROST pad once.
3. Press number pad 1 for Ground Meat.
4. Press number pad to enter the weight.
5. Press START pad.

NOTE: During defrosting program, the system will pause and sound beeps to remind user to turn food over, and then press START to resume the defrosting.

## MULTI-STAGE COOKING

---

Your oven can be programmed for up to 2 microwave cooking program.

Suppose you want to set the following cooking program.

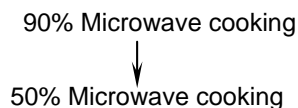

1. Press POWER LEVEL button to set 90% power level.
2. Use the number pads to enter cooking time.
3. Press POWER LEVEL button to set 50% power level.
4. Use the number pads to enter cooking time.
5. Press START button.

## MINUTE PLUS

---

This feature allows you to start the oven quickly at high power level.

Press the MINUTE PLUS pad once or repeatedly to set cooking time, the oven starts work at full power level

immediately. The maximum cooking time can be set is 99 minutes and 59 seconds.

## CHILD LOCK

Use to prevent unsupervised operation of the oven by little children. The CHILD LOCK indicator will show on display screen, and the oven cannot be operated while the CHILD LOCK is set.

To set the CHILD LOCK: Press and hold the STOP/CLEAR pad for 3 seconds, a beep sounds and LOCK indicator lights.

To cancel the CHILD LOCK: Press and hold the STOP/CLEAR pad for 3 seconds until lock indicator on display turns off.

## MENU COOK

For food or the following cooking mode, it is not necessary to program the time and the cooking power. It is sufficient to indicate the type of food that you want to cook as well as the weight of this food.

### POPCORN

1. In standby mode, press POPCORN pad once, the display shows "CODE", "1".
2. Press POPCORN pad to select different weight as shown below.
3. Press START pad to start cooking.

Press POPCORN	Weight
Once	3.5 oz.
Twice	2.85-3.5 oz.
3 times	1.2-1.6 oz.
4 times	1.5-1.75 oz.

### MELT

1. In standby mode, press MELT pad once, the display shows "CODE", "1".
2. Press MELT pad to select Butter or Chocolate.
3. Press number pad 1 or 2 to select weight.
4. Press START pad to start cooking.

Food	Number Pad	Weight
Butter	1	2 oz
	2	4 oz
Chocolate	1	4 oz (small fragment)
	2	4 oz (a whole piece)

### SOFTEN

1. In standby mode, press SOFTEN pad once, the display shows "CODE", "1".
2. Press SOFTEN pad to select Ice Cream or Cream Cheese.
3. Press number pad 1 or 2 to select weight.
4. Press START pad to start cooking.

Food	Number Pad	Weight
Ice Cream	1	1 lb
	2	4 lb
Cream Cheese	1	3 oz
	2	8 oz

#### WARM

1. In standby mode, press WARM pad once, the display shows "CODE", "1".
2. Press WARM pad to select Syrup or Dessert Topping.
3. Press number pad 1 or 2 to select weight.
4. Press START pad to start cooking.

Food	Number Pad	Weight
Syrup	1	150 ml
	2	300 ml
Dessert Topping	1	150 ml
	2	300 ml

#### COOK

1. In standby mode, press COOK pad once, the display shows "FOOD".
2. Press number pad 1 to 6 to select different food as shown below.
3. Press number pad to select unit.
4. Press START pad to start cooking.

Number pad	Food
1	Baked Potatoes (1-4 unit)
2	Fresh Vegetables (1-4 unit)
3	Frozen Vegetables (1-4 unit)
4	Frozen Entrees (1-4 unit)
5	Ground Meat (1-6 unit)
6	Rice (1-4 unit)

#### REHEAT

1. In standby mode, press REHEAT pad once, the display shows "FOOD".
2. Press number pad 1 to 6 to select different food as shown below.
3. Press number pad to select unit.
4. Press START pad to start cooking.

Number pad	Food
1	Pasta Sauce (1-4 unit)
2	Soup (1-4 unit)
3	Pizza (1-4 unit)
4	Dinner Plate (1-3 unit)
5	Beverage (1-4 unit)
6	Rolls/Muffins (1-6 unit)

# CLEANING AND CARE

1. Turn off the oven and remove the power plug from the wall socket before cleaning.
2. Keep the inside of the oven clean. When food splatters or spilled liquids adhere to oven walls, wipe them with a damp cloth. Mild detergent may be used if the oven gets very dirty. Avoid the use of spray and other harsh cleaners as they may stain, streak or dull the door surface.
3. The outside surfaces should be cleaned with a damp cloth. To prevent damage to the operating parts inside the oven, water should not be allowed to seep into the ventilation openings.
4. Wipe the door and window on both sides, as well as the door seals and adjacent parts frequently with a damp cloth to remove any spills or spatters. Do not use abrasive cleaner.
5. Do not allow the control panel to become wet. Clean with a soft, damp cloth. When cleaning the control panel, leave oven door open to prevent oven from accidentally turning on.
6. If steam accumulates inside or around the outside of the oven door, wipe with a soft cloth. This may occur when the microwave oven is operated under high humidity condition.
7. It is occasionally necessary to remove the glass tray for cleaning. Wash the tray in warm sudsy water or in a dishwasher.
8. The roller ring and oven floor should be cleaned regularly to avoid excessive noise. Simply wipe the bottom surface of the oven with mild detergent. The roller ring may be washed in mild sudsy water or dishwasher. When removing the roller ring from cavity floor for cleaning, be sure to replace in the proper position.
9. Remove odors from your oven by combining a cup of water with the juice and skin of one lemon in a deep microwaveable bowl, microwave for 5 minutes. Wipe thoroughly and dry with a soft cloth.
10. When it becomes necessary to replace the oven light, please consult a dealer to have it replaced.
11. The oven should be cleaned regularly and any food deposits removed. Failure to maintain the oven in a clean condition could lead to deterioration of the surface that could adversely affect the life of the appliance and possibly result in a hazardous situation.
12. Please do not dispose this appliance into the domestic rubbish bin, it should be disposed to the particular disposal center provided by the municipalities.