

## 1.6 Cu. Ft. Countertop Microwave



**Model: P11043AP-YZ**

# TABLE OF CONTENTS

IMPORTANT SAFETY INSTRUCTIONS	2
PRECAUTIONS TO AVOID POSSIBLE EXPOSURE TO EXCESSIVE MICROWAVE ENERGY	3
INSTALLATION GUIDE	4
GROUNDING INSTRUCTIONS	4
PRODUCT DIAGRAM	5
CONTROL PANEL	6
INSTALLING THE TURNTABLE	6
OPERATION INSTRUCTIONS	7
COOKING UTENSILS GUIDE	11
COOKING TECHNIQUES	12
CLEANING AND CARE	14
BEFORE CALLING FOR SERVICE	14
SPECIFICATIONS	15

# IMPORTANT SAFETY INSTRUCTIONS

## READ ALL SAFETY INSTRUCTIONS BEFORE USING THIS MICROWAVE

WARNING - to reduce the risk of burns, electric shock, fire, injury to persons, or exposure to excessive microwave energy, basic safety precautions should be followed, including the following:

1. Read all instructions before using the microwave.
2. This microwave must be grounded. Connect only to properly grounded outlets. See page 4 for grounding instructions.
3. Install or place this microwave only in accordance with installation instructions.
4. Some produce such as whole eggs and sealed containers-for example, closed glass jars - are able to explode and should not be heated in this oven.
5. This microwave is intended for use only as described in this manual. Do not use corrosive chemicals or vapors in this microwave. This type of microwave is specifically designed to heat, cook, or dry foods. It is not designed for laboratory use.
6. As with any appliance, close supervision is necessary when used by children.
7. To reduce the risk of fire in the oven cavity, do not overcook food. Carefully attend to the microwave when paper, plastic, or other combustible materials are placed inside the microwave to facilitate cooking.
8. Remove wire twist-ties from paper or plastic bags before placing in microwave.
9. If materials inside the microwave should ignite, keep microwave door closed, turn it off, and disconnect the power cord or turn off the power fuse at the circuit breaker panel. Do not use the microwave cavity for storage purposes.
10. Do not leave paper products, cooking utensils, or food in the cavity when not in use.
11. Liquids, such as water, coffee, or tea may overheat beyond the boiling point without appearing to be boiling due to surface tension of the liquid. Visible bubbling or boiling when the container is removed from the microwave is not always present. **THIS COULD RESULT IN VERY HOT LIQUIDS SUDDENLY BOILING OVER WHEN A SPOON OR OTHER UTENSIL IS INSERTED INTO THE LIQUID.** To reduce the risk of injury: do not overheat the liquid; stir the liquid both before and halfway through heating; do not use straight-sided containers with narrow necks; after heating, allow the container to stand in the microwave a short time before removing; use extreme care when inserting a spoon or other utensil into the container.
12. Do not heat oil or fat for deep-frying in this microwave. It is difficult to control the temperature of oil in the microwave.
13. Pierce foods with heavy skins, such as potatoes, before cooking.
14. The contents of feeding bottles and baby jars should be stirred or shaken and the temperature should be checked before serving to avoid burns.
15. Cooking utensils may become hot from heat transferred from the heated food. Pot holders may be needed to handle these utensils.
16. Do not cover or block any openings on the microwave.
17. Do not store or use this microwave outdoors. Do not use this microwave near water, for example, near a kitchen sink, in a wet basement, near a swimming pool, or similar location.
18. Do not operate this microwave if it has a damaged cord or plug, if it is not working properly, or if it has been damaged or dropped.
19. Do not immerse the cord or plug in water. Keep cord away from heated surfaces. Do not let the cord hang over the edge of the table or counter.

**SAVE THESE INSTRUCTIONS**

## **IMPORTANT SAFETY INSTRUCTIONS (continued)**

20. Use only thermometers specifically designed for microwaves.
21. Do not operate any heating or cooking under this microwave.
22. Be certain the glass tray and roller rings are in place when using the microwave.
23. Read and follow the specific "Precautions to Avoid Possible Exposure to Excessive Microwave Energy" section found on page 3.
24. When cleaning microwave surface and door, use only mild, nonabrasive soaps or detergents applied with a sponge or soft cloth.

## **PRECAUTIONS TO AVOID POSSIBLE EXPOSURE TO EXCESSIVE MICROWAVE ENERGY**

1. Do not attempt to operate this microwave with the door open. Door open operation can result in harmful exposure to microwave energy. It is important not to defeat or tamper with the safety interlocks.
2. Do not place any objects between the microwave front face and the door, or allow soil or cleaner residue to accumulate on sealing surfaces.
3. Do not operate the microwave if damaged. It is particularly important that the microwave door be properly closed and there is no damage to the door (bent), hinges and latches (broken or loosened), or door seals and sealing surfaces.
4. The microwave should not be adjusted or repaired by anyone except properly qualified service personnel.

**SAVE THESE INSTRUCTIONS**

# INSTALLATION GUIDE

1. Make sure all packing materials are removed from inside the microwave door.
2. Check the microwave for damage, such as misaligned or bent door, damaged door seals and sealing surface, broken or loose door hinges and latches, and dents inside the cavity or on the door.
3. This microwave must be placed on a flat, stable surface to hold its weight and the heaviest food likely to be cooked inside.
4. Do not place the oven where heat, moisture, or high humidity is generated. Do not place microwave near combustible materials.
5. For correct operation, the oven must have sufficient air flow. Allow 8" of space above the microwave, 4" at the back, and 2" on each side of the unit.
6. Do not cover or block any openings on the microwave. Do not remove microwave feet. Do not operate the oven without the glass tray, roller support, and shaft in their proper positions. Make sure the power supply cord is undamaged and does not run under the microwave or over any hot or sharp surface.
7. The socket must be readily accessible so the microwave can be easily unplugged in an emergency.

# GROUNDING INSTRUCTIONS

This microwave must be grounded. In the event of an electrical short circuit, grounding reduces risk of electric shock by providing an escape wire for the electric current. Consult a qualified electrician or serviceman if the grounding instructions are not completely understood, or if doubt exists as to whether the appliance is properly grounded. Consult a qualified electrician or serviceman if the grounding instructions are not completely understood, or if doubt exists as to whether the appliance is properly grounded, and either:

- 1) If it is necessary to use an extension cord, use only a 3-wire extension cord that has a 3-blade grounding plug and a 3-slot receptacle that will accept the plug on the appliance. The marked rating of the extension cord shall be equal to or greater than the electrical rating of the appliance, or
- 2) Do not use an extension cord. If the power supply cord is too short, have a qualified electrician or serviceman install an outlet near the appliance.

**WARNING:** Improper use of the grounding plug can result in risk of electric shock.

## ELECTRICAL REQUIREMENTS

---

- The electrical requirements for this microwave are a 120V, 60Hz, AC only, 20 amp.
- It is recommended that a separate circuit serving only the microwave be provided.
- The microwave is equipped with a 3-prong grounding plug. It must be plugged into a wall outlet properly installed and grounded.

# GROUNDING INSTRUCTIONS (continued)

## POWER CORD

- A short power supply cord is provided to reduce the risks resulting from becoming entangled in or tripping over a long cord.
- Longer cord sets or extension cords are available and may be used if care is taken in using them.
- If using a longer cord, the marked electrical rating of the cord set or extension cord should be at least as great as the electrical marking of the microwave itself and the extension cord must be a grounded-type 3-wire cord. The longer cord should be arranged so it will not drape over the counter or tabletop.

### Notes:

- If you have any questions about the grounding or electrical instructions, consult a qualified electrician or service person.
- Neither the manufacturer nor the dealer can accept any liability for damage to the oven or personal injury resulting from failure to observe the electrical connection procedures.

## Radio or TV Interference

Please save sales receipt for warranty.

This equipment generates, uses and can radiate radio frequency energy and, if not installed and used in accordance with the instructions, may cause harmful interference to radio communications. However, there is no guarantee that interference will not occur in a particular installation. If this equipment does cause harmful interference to radio or television reception, which can be determined by turning the equipment off and on, the user is encouraged to try to correct the interference by one or more of the following measures:

- Reorient or relocate the receiving antenna.
- Increase the separation between the equipment and receiver.
- Connect the equipment into an outlet on a circuit different from that to which the receiver is connected.
- Consult the dealer or an experienced radio/TV technician for help

## PRODUCT DIAGRAM

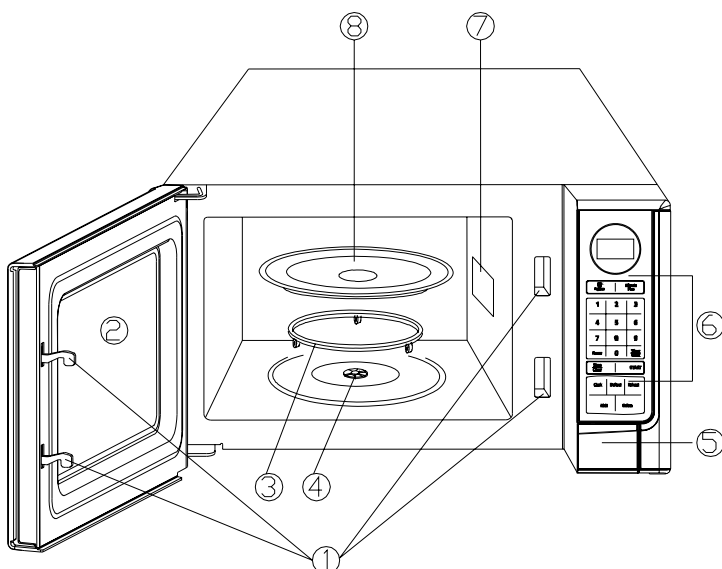

1. Door Safety Lock System
2. Oven Window
3. Roller Ring
4. Shaft
5. Door Release Button
6. Control Panel
7. Wave Guide
8. Glass Tray

# CONTROL PANEL

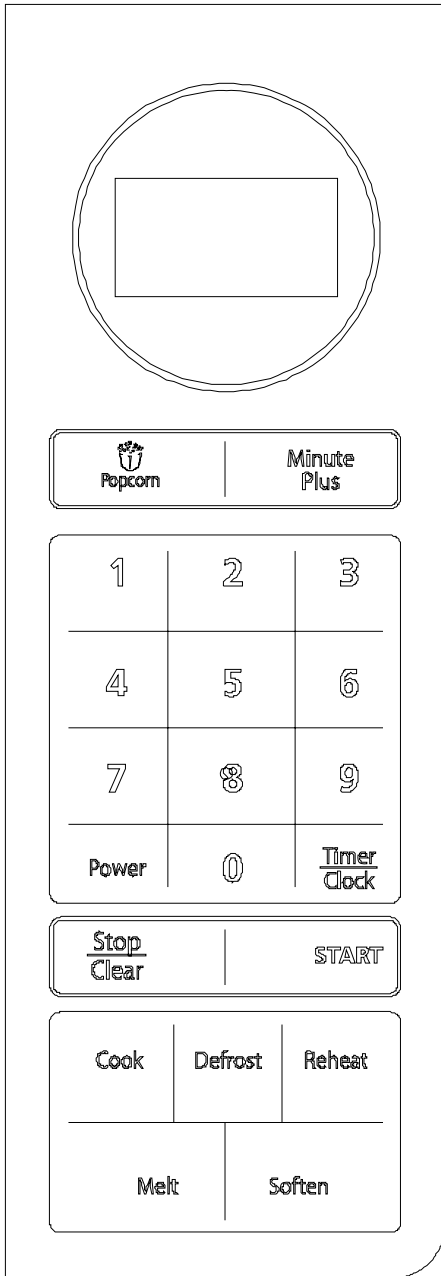

- **MENU ACTION SCREEN**

Cooking time, power, indicators and present time are displayed.

- **MINUTE PLUS**

Touch to add cooking time.

- **NUMBER PADS(0-9)**

Touch to set clock, cooking time or enter food weight.

- **POWER**

Use to set microwave power levels.

- **TIMER/CLOCK**

Touch to set TIMER or CLOCK function.

- **STOP/CLEAR**

Touch to stop the oven or reset the oven before setting a program.  
Touch to set the SAFETY LOCK.

- **DEFROST**

Easy settings to defrost according to weight entered.

- **START**

Touch to start the oven; also use to add cooking time during cooking progress.

- **DEFROST**

Use to defrost frozen meat and poultry by weight.

- **AUTO MENU BUTTONS**

Choose various weights fast cooking food

**Popcorn**

**Cook**

**Reheat**

**Melt**

**Soften**

# INSTALLING THE TURNTABLE

- Never place the glass tray upside down.
- The glass tray should never be restricted.
- Both the glass tray and turntable ring assembly must always be used during cooking.
- All food and containers of food should always be placed on the glass tray for cooking.

- If the glass tray or turntable ring assembly cracks or breaks, contact your nearest authorized service center.

# OPERATION INSTRUCTIONS

## SETTING THE CLOCK

---

1. Touch TIMER/ CLOCK pad.
2. Use the number pads to enter the correct time.
3. Touch TIMER/ CLOCK pad again.

**NOTE:**

- This is a 12 hour clock. If you continuous touch "TIMER/CLOCK" pads twice, the system will show "EE", it is wrong. Only according to "STOP/CLEAR" key once, you can operate the microwave oven.

## SETTING THE TIMER

---

The countdown longest time is 99 minutes and 99 seconds.

1. Press STOP/CLEAR pad to reset the oven.
2. Use the number pads to enter time.
3. Press TIMER/CLOCK pad to start timer.

**NOTE:**

1. The maximum time you can enter is 99 minutes and 99 seconds.
2. If you want to cancel the timer, press STOP/CLEAR pad.
3. When the countdown ends, the buzzer will beep to remind you.

## MICROWAVE COOKING

---

The longest cooking time is 99 minutes and 99 seconds.

You can select the power level by pressing POWER:

Press POWER pad	Cooking Power	Press POWER pad	Cooking Power
Once	100% (P-HI)	7 times	40% (P-40)
Twice	90% (P-90)	8 times	30% (P-30)
3 times	80% (P-80)	9 times	20% (P-20)
4 times	70% (P-70)	10 times	10% (P-10)
5 times	60% (P-60)	11 times	0% (P--0)
6 times	50% (P-50)		

Suppose you want to cook for 5 minutes at 60%:

1. Press STOP/CLEAR pad to reset the oven.
2. Touch POWER pad to select power level "P-60".
3. Use the number pads to enter cooking time "5:00".
4. Press START pad to start.

**NOTE:**

You can check power level during cooking by pressing POWER pad.



During the cooking process, you click "MINUTE PLUS" key once, can increase 1 minutes of cooking time.

## OPERATION INSTRUCTIONS (continued)

### MINUTE PLUS

---

You can set 100% power level cooking quickly by pressing this button to set 1 minute each time. The longest time you can set is 99 minutes and 59 seconds.

### DRFROST

---

The oven could be used to defrost food on the weight you entered. The defrosting time and power level are automatically set once the weight is programmed.

FOR EXAMPLE: Suppose you want to defrost food.

1. Press STOP/CLEAR pad to reset the oven.
2. Press DEFROST pad once.
3. Press number 1~4 to select food code.
4. Press the number pads to enter weight.

Code Food	Press number	Weight
1.Ground Meat	1	8OZ-2LB
2.Steaks/Chops	2	8OZ-3LB
3.Boneless Poultry	3	8OZ-1LB 8OZ
4.Bone-in Poultry	4	8OZ-3LB

5. Press START pad.

NOTE: During defrosting process, the system will pause to remind user to turn food over, after that, press START to resume.

### MULTIPLE COOKING

---

The microwave oven can set 2 period of microwave cooking program

Suppose you want set the following cooking program:

**Paragraph 1:** Microwave and power level cooking (2 minutes at 100%);

**Paragraph 2:** Microwave and power level cooking (5 minutes at 60%);

1. Press STOP/CLEAR pad to reset the oven.

**Paragraph 1:**

2. Touch POWER pad to select "P-HI" power level.
3. Use the number pads to enter cooking time "2:00".

**Paragraph 2:**

4. Touch POWER pad to select "P-60" power level.
5. Use the number pads to enter cooking time "5:00".
6. Press START pad to start.

# OPERATION INSTRUCTIONS (continued)

## AUTO MENU

### Popcorn

1. Press STOP/CLEAR pad to reset the oven.
2. Press POPCORN pad to select 1~4 amt.

Press Popcorn pad	Display AMT	Weight
Once	1	3.5 OZ
Twice	2	2.85 ~ 3.5 OZ
Thrice	3	1.2 ~ 1.6 OZ
4 times	4	1.5 ~ 1.75 OZ

3. Press START pad to start.

### MELT

1. Press STOP/CLEAR pad to reset the oven.
2. Press MELT pad once or twice to select Code "1" or "2".
3. Press the number "1" or "2" to select food weight.

Code Food	Press Melt pad	Press number	Weight	
1.Butter	Once	1	Once	2 OZ
			Twice	4 OZ
2.Chocolate	Twice	2	Once	4 OZ(Brokenshape)
			Twice	4 OZ(block)

4. Press START pad to start.

### SOFTEN

1. Press STOP/CLEAR pad to reset the oven.
2. Press SOFTEN pad once or twice to select code "1" or "2".
3. Press the number "1" or "2" to select food weight.

Code Food	Press Soften pad	Press number	Weight	
1.Ice Cream	Once	1	Once	1 LB
			Twice	4 LB
2.Cream Cheese	Twice	2	Once	3 OZ
			Twice	8 OZ

4. Press START pad to start.

# OPERATION INSTRUCTIONS (continued)

## COOK

1. Press STOP/CLEAR pad to reset the oven.
2. Press COOK pad once.
3. Press number 1~6 to select food code.
4. Press the corresponding number to select food servings.

Code Food	Press number	Servings	Code Food	Press number	Servings		
1.Baked Potatos	1	Once	4.Frozen Entrees	4	Once		
		Twice			2	Twice	2
		Thrice			3	Thrice	3
		4 times			4	4 times	4
2.Fresh Vegetables	2	Once	5.Ground Meat	5	Once		
		Twice			2	Twice	2
		Thrice			3	Thrice	3
		4 times			4	4 times	4
3.Frozen Vegetables	3	Once	6.Rice	6	5 times		
		Twice			2	6 times	6
		Thrice			3	Once	1
		4 times			4	Twice	2
					Thrice	3	
					4 times	4	

5. Press START pad to start.

## REHEAT

1. Press STOP/CLEAR pad to reset the oven.
2. Press REHEAT pad once.
3. Press number 1~6 to select food code.
4. Press the corresponding number to select food servings.

Code Food	Press number	Servings	Code Food	Press number	Servings		
1.Pasta Sauce	1	Once	4.Dinner Plate	4	Once		
		Twice			2	Twice	2
		Thrice			3	Thrice	3
		4 times			4	Once	1
2.Soup	2	Once	5.Beverage	5	Twice		
		Twice			2	Thrice	3
		Thrice			3	4 times	4
		4 times			4	Once	1
3.Pizza	3	Once	6.Rolls/Muffins	6	Twice		
		Twice			2	Thrice	3
		Thrice			3	4 times	4
		4 times			4	5 times	5
					6 times	6	

5. Press START pad to start.

# OPERATION INSTRUCTIONS (continued)

## CHILD LOCK

---

Use to prevent unsupervised operation of the oven by little children. The Child Lock indicator will on display screen, and the oven can not be operated while the Child Lock is set.

To set: In standby mode, press and hold the STOP/CLEAR button for 3 seconds, a beep sounds and lock indicator lights.

To cancel: Press and hold the STOP/CLEAR button for 3 seconds until lock indicator light on display turns off.

## COOKING UTENSILS GUIDE

This section lists which utensils can be used in this microwave, which have limited use for short periods, and which should not be used in this microwave.

### RECOMMENDED

---

**Microwave browning dish** -- Use to brown the exterior of small items such as steaks, chops, or pancakes. Follow the directions provided with your browning dish.

**Microwaveable plastic wrap** -- Use to retain steam. Leave a small opening for some steam to escape and avoid placing it directly on the food.

**Paper towels and napkins** -- Use for short-term heating and covering; these absorb excess moisture and prevent splattering. Do not use recycled paper towels which may contain metal and could ignite.

**Glass and glass-ceramic bowls and dishes** -- Use for heating and cooking.

**Paper plates and cups** -- Use for short-term heating at low temperatures. Do not use recycled paper which may contain metal and could ignite.

**Wax paper** -- Use as a cover to prevent splattering.

**Thermometers** -- Use only those labeled "Microwave Safe" and follow all directions. Check the food in several places. Conventional thermometers may be used on microwaved food once the food has been removed from the microwave.

### LIMITED USE

---

**Aluminum foil** -- Use narrow strips of foil to prevent overcooking exposed areas. Using too much foil can damage your microwave, so be careful. Keep 1" between foil and microwave cavity.

**Ceramic, porcelain, and stoneware** -- Use these if they are labeled "Microwave Safe". If they are not labeled, test them to make sure they can be used safely.

**Plastic** -- Only use if labeled "Microwave Safe". Other plastics may melt.

# COOKING UTENSILS GUIDE (continued)

## NOT RECOMMENDED

---

**Glass jars and bottles** -- Regular glass is too thin to be used in a microwave. It can shatter and cause damage and injury.

**Paper bags** -- These are a fire hazard, except for popcorn bags that are designed for microwave use.

**Styrofoam plates and cups** -- These can melt and leave unhealthy residue on food.

**Plastic storage and food containers** -- Containers such as margarine tubs can melt in the microwave.

**Metal utensils** -- These can damage your microwave. Remove all metal before cooking.

Note:

- Should you wish to check if a dish is safe for microwaving, place the empty dish in the microwave and microwave on high for 30 seconds. A dish that becomes very hot should not be used.

# COOKING TECHNIQUES

Your microwave makes cooking easier than conventional cooking, provided you keep these considerations in mind:

## STIRRING

---

- Stir foods such as casseroles and vegetables while cooking to distribute heat evenly.
- Food at the outside of the dish absorbs more energy and heats quicker, so stir from the outside to the center.
- The microwave will turn off when you open the door to stir your food.

## ARRANGEMENT

---

- Arrange evenly shaped foods, such as chicken pieces or chops, with the thicker, meatier parts towards the outside of the turntable where they receive more microwave energy.
- To prevent overcooking, place delicate areas, such as asparagus tips, towards the center of the turntable.

## SHIELDING

---

- Shield food with narrow strips of aluminum foil to prevent overcooking.
- Areas that need shielding include poultry wing tips, the ends of poultry legs, and corners of square baking dishes.
- Use only small amounts of aluminum foil, as larger amounts may damage your microwave.

# COOKING TECHNIQUES (continued)

## TURNING

---

- Turn foods over midway through cooking to expose all parts to microwave energy.
- This is especially important when cooking large foods such as roasts.

## STANDING

---

- Foods cooked in a microwave build up internal heat and continue to cook for a few minutes after heating stops.
- Let foods stand to complete cooking, especially for foods such as cakes and whole vegetables.
- Roasts need this time to complete cooking in the center without overcooking the outer areas.
- All liquids, such as soup or hot chocolate, should be shaken or stirred when cooking is complete.
- When heating baby food, stir well after removing from microwave and test temperature before serving.

## ADDING MOISTURE

---

- Microwave energy is attracted to water molecules.
- Food that is uneven in moisture content should be covered or allowed to stand so that the heat disperses evenly.
- Add a small amount of water to dry food to help it cook.

## CLEANING AND CARE

1. Turn off the microwave and unplug the power cord from the wall when cleaning.
2. Keep the inside of the microwave clean. When food splatters or spilled liquids adhere to microwave walls, wipe with a damp cloth. Mild detergents may be used if the microwave gets very dirty. Avoid using spray or other harsh cleaners. They may stain, streak, or dull the door surface.
3. The outside of the microwave should be cleaned with a damp cloth. To prevent damage to the operating parts inside the microwave, water should not be allowed to seep into the ventilation openings.
4. Wipe the window on both sides with a damp cloth to remove any spills or splatters.
5. Do not allow the control panel to become wet. Clean with a soft, damp cloth. When cleaning the panel, leave the microwave door open to prevent it from accidentally turning on.
6. If steam accumulates inside or around the outside of the door, wipe with a soft cloth. This may occur when the microwave is operated under high humidity. This is normal.
7. It may be necessary to remove the glass tray for cleaning. Wash the tray in warm, soapy water or in a dishwasher. The roller ring and microwave floor should be cleaned regularly to avoid excessive noise. Wipe the bottom surface of the microwave with a mild detergent.
8. The roller ring may be washed in mild, soapy water or in a dishwasher. When removing the roller ring, be sure to replace it in the proper position.
9. Remove odors from your microwave by combining a cup of water with the juice and skin of one lemon in a microwaveable bowl. Microwave for 5 minutes. Wipe thoroughly and dry with a soft cloth.
10. The microwave should be cleaned regularly and any food deposits should be removed. Failure to maintain the microwave in a clean condition could lead to deterioration of surfaces that could adversely affect the life of the unit and could possibly result in a hazardous situation.
11. Please do not dispose of this appliance into a regular garbage receptacle. Please check to see where you can dispose such appliances.
12. Keep the wave guide clean. Build-up splashes may overheat and cause smoke or possibly catch fire. Carefully wipe with a soft damp cloth food splatters.

## BEFORE CALLING FOR SERVICE

Before asking for service, please check each item below:

- Check to ensure the microwave is plugged in securely. If not, remove the plug from the outlet, wait 10 seconds, and plug it in again securely.
- Check for a blown circuit fuse or a tripped main circuit breaker. If these seem to be operating properly, test the outlet with another appliance.
- Check to ensure the control panel is programmed correctly and the timer is set.
- Check to ensure the door is securely closed, engaging the door safety lock system. If the door is not properly closed, the microwave energy will not flow inside.

# SPECIFICATIONS

Power Consumption	120V~60Hz, 1600W
Output	1100W
Operation Frequency	2450MHz
Outside Dimensions (HxWxD)	12 1/4 x 21 3/4 x 17 3/4 inches
Oven Cavity Dimensions (HxWxD)	9 13/16 x 15 3/4 x 17 inches
Oven Capacity	1.6 cu. ft.
Cooking Uniformity	Turtable System
Net Weight	Approx. 38.3 lbs.





©2014 Sunbeam Products, Inc. doing business as Jarden Consumer Solutions. All rights reserved.

Oster® logo is a registered trademark of Sunbeam Products, Inc. used under license.

Distributed by Guangdong Galanz Microwave Oven and Electrical Appliances Manufacturing Co., Ltd.,

Shunde, Foshan, Guangdong, 528305, China  
For service, support and warranty information, call 800-324-0340.