

Microwave Oven

User's manual

Please read these instructions carefully before installing and operating the oven.

Record in the space below the SERIAL NO. found on the nameplate on your oven and retain this information for future reference.

SERIAL NO.

技术要求：产品要符合 ROHS2.0 指令要求

					说明书 SBD602DPB-PAHCOA (P120D60EPH-DP)				JS1M0609-20978-004-(0)					
标记	处数	更改单号	签字	日期										
设计	康婧	标准化	关业红		图样标记	数量	重量	比例						
校对		审定	李丰		S A			1:1	广东格兰仕微波炉 电器制造有限公司					
审核	杨瑞其													
工艺		日期	2016-1-27		共 13 页	第 1 页								

PRECAUTIONS TO AVOID POSSIBLE EXPOSURE TO EXCESSIVE MICROWAVE ENERGY

1. Do not attempt to operate this oven with the door-open since open-door operation can result in harmful exposure to microwave energy. It is important not to defeat or tamper with the safety interlocks.
2. Do not place any object between the oven front face and the door or allow soil or cleaner residue to accumulate on sealing surfaces.
3. Do not operate the oven if it is damaged. It is particularly important that the oven door close properly and that there is no damage to the:
 - a) Door (bent),
 - b) Hinges and latches (broken or loosened),
 - c) Door seals and sealing surfaces.
4. The oven should not be adjusted or repaired by anyone except properly qualified service personnel.

CONTENT

PRECAUTIONS TO AVOID POSSIBLE EXPOSURE TO EXCESSIVE MICROWAVE ENERGY	1
IMPORTANT SAFETY INSTRUCTIONS	2
INSTALLATION GUIDE.....	4
GROUNDING INSTRUCTIONS.....	4
UTENSILS GUIDE	5
COOKING TECHNIQUES.....	6
SPECIFICATIONS	7
PART NAMES	7
CONTROL PANEL	8
OPERATION INSTRUCTIONS	9
Setting the clock.....	9
Microwave cooking	9
Express cook	9
Adjust the cooking time	10
Keep warm	10
Setting the timer.....	10
Time defrost	10
Weight defrost.....	10
Multiple cooking	11
Sensor cook	11
Auto Cook	12
Child lock	12
CLEANING AND CARE	13

IMPORTANT SAFETY INSTRUCTIONS

When using electrical appliances, basic safety precautions should be followed, including the following:

WARNING - To reduce the risk of burns, electric shock, fire, and injury to persons or exposure to excessive microwave energy:

1. Read all instructions before using the appliance.
2. Read and follow the specific "PRECAUTIONS TO AVOID POSSIBLE EXPOSURE TO EXCESSIVE MICROWAVE ENERGY" on page 1.
3. This appliance must be grounded. Connect only to properly grounded outlet. See "GROUNDING INSTRUCTIONS" on page 4.
4. Install or locate this appliance only in accordance with the provided installation instructions.
5. Some products such as whole eggs and sealed containers -for example, closed glass jars- are able to explode and should not be heated in this oven.
6. Use this appliance only for its intended use as described in this manual. Do not use corrosive chemicals or vapors in this appliance. This type of oven is specifically designed to heat, cook, or dry food. It is not designed for industrial or laboratory use.
7. As with any appliance, close supervision is necessary when used by children.
8. To reduce the risk of fire in the oven cavity:
 - a) Do not overcook food. Carefully attend appliance when paper, plastic, or other combustible materials are placed inside the oven to facilitate cooking.
 - b) Remove wire twist-ties from paper or plastic bags before placing bag in oven.
 - c) If materials inside the oven should ignite, keep oven door closed, turn oven off, and disconnect the power cord or shut off power at the fuse or circuit breaker panel.
 - d) Do not use the cavity for storage purposes. Do not leave paper products, cooking utensils or food in the cavity when not in use.
9. Liquids, such as water, coffee, or tea are able to be overheated beyond the boiling point without appearing to be boiling. Visible bubbling or boiling when the container is removed from the microwave oven is not always present. **THIS COULD RESULT IN VERY HOT LIQUIDS SUDDENLY BOILING OVER WHEN THE CONTAINER IS DISTURBED OR A UTENSIL IS INSERTED INTO THE LIQUID.** To reduce the risk of injury to person:
 - a) Do not overheat the liquid.
 - b) Stir the liquid both before and halfway through heating it.
 - c) Do not use straight-sided containers with narrow necks.
 - d) After heating, allow the container to stand in the microwave oven for a short time before removing the container.
 - e) Use extreme care when inserting a spoon or other utensil into the container.
10. Do not heat oil or fat for deep-frying. It is difficult to control the temperature of oil in microwave oven.
11. Pierce foods with heavy skins such as potatoes, whole squash, apples and chestnuts before cooking.
12. The contents of feeding bottles and baby jars should be stirred or shaken and the temperature should be checked before serving in order to avoid burns.
13. Cooking utensils may become hot because of heat transferred from the heated food. Potholders may be needed to handle the utensil.

14. Do not cover or block any openings on the appliance.
15. Do not store or use this appliance outdoors. Do not use this product near water, for example, near a kitchen sink, in a wet basement, near a swimming pool, or similar locations.
16. Do not operate this appliance if it has a damaged cord or a plug, if it is not working properly or if it has been damaged or dropped.
17. Do not immerse cord or plug in water. Keep cord away from heated surface. Do not let cord hang over edge of table or counter.
18. Use only thermometers, which are specifically designed for use in microwave ovens.
19. Do not operate any heating or cooking appliance beneath this appliance.
20. Be certain the glass tray and roller rings are in place when you operate the oven.
21. This appliance should be serviced only by qualified service personnel. Contact nearest authorized service facility for examination, repair, or adjustment.
22. When cleaning surfaces of door and oven that comes together on closing the door, use only mild, nonabrasive soaps, or detergents applied with a sponge or soft cloth.
23. This equipment generates, uses and can radiate radio frequency energy and, if not installed and used in accordance with the instructions, may cause harmful interference to radio communications. However, there is no guarantee that interference will not occur in a particular installation. If this equipment does cause harmful interference to radio or television reception, which can be determined by turning the equipment off and on, the user is encouraged to try to correct the interference by one or more of the following measures:
 - Reorient or relocate the receiving antenna.
 - Increase the separation between the equipment and receiver.
 - Connect the equipment into an outlet on a circuit different from that to which the receiver is connected.
 - Consult the dealer or an experienced radio/TV technician for help.

SAVE THESE INSTRUCTIONS

INSTALLATION GUIDE

1. Make sure that all the packing materials are removed from the inside of the door.
2. Check the oven for any damage, such as misaligned or bent door, damaged door seals and sealing surface, broken or loose door hinges and latches and dents inside the cavity or on the door. If there is any damage, do not operate the oven but contact qualified service personnel.
3. This microwave oven must be placed on a flat, stable surface to hold its weight and the heaviest food likely to be cooked in the oven.
4. Do not place the oven where heat, moisture, or high humidity are generated, or near combustible materials.
5. For correct operation, the oven must have sufficient airflow. Allow 20cm of space above the oven, 10cm at back and 5cm at both sides. Do not cover or block any openings on the appliance. Do not remove feet on which oven stands.
6. The appliance shall be only used on a countertop over 3 feet above the floor.
7. Do not operate the oven without glass tray, roller support, and shaft in their proper positions.
8. Make sure that the power supply cord is undamaged and does not run under the oven or over any hot or

GROUNDING INSTRUCTIONS

This appliance must be grounded. In the event of an electrical short circuit, grounding reduces risk of electric shock by providing an escape wire for the electric current.

WARNING Improper use of the grounding plug can result in a risk of electric shock.

Consult a qualified electrician or serviceman if the grounding instructions are not completely understood, or if doubt exists as to whether the appliance is properly grounded, and either:

1) If it is necessary to use an extension cord, use only a 3-wire extension cord that has a 3-blade grounding plug and a 3-slot receptacle that will accept the plug on the appliance. The marked rating of the extension cord shall be equal to or greater than the electrical rating of the appliance, or 2) Do not use an extension cord. If the power supply cord is too short, have a qualified electrician or serviceman install an outlet near the appliance.

Electrical Requirements

The electrical requirements are a 120 volt 60 Hz, AC only, 20 amp. It is recommended that a separate circuit serving only the oven be provided. The oven is equipped with a 3-prong grounding plug. It must be plugged into a wall receptacle that is properly installed and grounded.

Power Supply Cord

1. A short power supply cord is provided to reduce the risks resulting from becoming entangled in or tripping over a longer cord.
2. Longer cord sets or extension cords are available and may be used if care is exercised in their use.
3. If long cord or extension cord is used:

- a) The marked electrical rating of the cord set or extension cord should be at least as great as the electrical rating of the appliance.
- b) The extension cord must be a grounding-type 3-wire cord, and The longer cord should be arranged so that it will not drape over the counter top or table top where it can be pulled on by children or tripped over unintentionally.

Notes:

1. If you have any questions about the grounding or electrical instructions, consult a qualified electrician or service person.
2. Neither Galanz nor the dealer can accept any liability for damage to the oven or personal injury resulting from failure to observe the electrical connection procedures.

Radio or TV Interference

Should there be any interference caused by the microwave oven to your radio or TV, check that the microwave oven is on a different circuit, relocated the radio or TV as far away from the oven as feasible or check position and signal of receiving antenna.

UTENSILS GUIDE

This section lists which utensils can be used in the microwave, which ones have limited use for short periods, and which ones should not be used in the microwave.

RECOMMENDED

Microwave browning dish — Use to brown the exterior of small items such as steaks, chops, or pancakes. Follow the directions provided with your browning dish.

Microwaveable plastic wrap — Use to retain steam. Leave a small opening for some steam to escape and avoid placing it directly on the food.

Paper towels and napkins — Use for short-term heating and covering; these absorb excess moisture and prevent spattering. Do not use recycled paper towels, which may contain metal and could ignite.

Glass and glass-ceramic bowls and dishes — Use for heating or cooking.

Paper plates and cups — Use for short-term heating at low temperatures. Do not use recycled paper, which may contain metal and could ignite.

Wax paper — Use as a cover to prevent spattering.

Thermometers — Use only those labeled "Microwave Safe" and follow all directions. Check the food in several places. Conventional thermometers may be used on microwave food once the food has been removed from the oven.

LIMITED USE

Aluminum foil — Use narrow strips of foil to prevent overcooking of exposed areas. Using too much foil can damage your oven, so be careful. You should keep distance of 1 inch (2.54cm) between aluminum foil and cavity.

Ceramic, porcelain, and stoneware— Use these if they are labeled "Microwave Safe". If they are not labeled, test them to make sure they can be used safely.

Plastic — Use only if labeled "Microwave Safe". Other plastics can melt.

Not Recommended

Glass jars and bottles — Regular glass is too thin to be used in a microwave. It can shatter and cause damage and injury.

Paper bags — These are a fire hazard, except for popcorn bags that are designed for microwave use.

Styrofoam plates and cups — These can melt and leave an unhealthy residue on food.

Plastic storage and food containers — Containers such as margarine tubs can melt in the microwave.

Metal utensils — These can damage your oven. Remove all metal before cooking.

Note: Should you wish to check if a dish is safe for microwaving, place the empty dish in the oven and microwave on HIGH for 30 seconds. A dish which becomes very hot should not be used.

COOKING TECHNIQUES

Your microwave makes cooking easier than conventional cooking, provided you keep these considerations in mind:

STIRRING

Stir foods such as casseroles and vegetables while cooking to distribute heat evenly. Food at the outside of the dish absorbs more energy and heats more quickly, so stir from the outside to the center. The oven will turn off when you open the door to stir your food.

ARRANGEMENT

Arrange unevenly shaped foods, such as chicken pieces or chops, with the thicker, meatier parts toward the outside of the turntable where they receive more microwave energy. To prevent overcooking, place delicate areas, such as asparagus tips, toward the center of the turntable.

SHIELDING

Shield food with narrow strips of aluminum foil to prevent overcooking. Areas that need shielding include poultry wing tips, the ends of poultry legs, and corners of square baking dishes. Use only small amounts of aluminum foil. Larger amounts can damage your oven.

TURNING

Turn foods over midway through cooking to expose all parts to microwave energy. This is especially important with large foods such as roasts.

STANDING

Foods cooked in the microwave build up internal heat and continue to cook for a few minutes after heating stops. Let foods stand to complete cooking, especially foods such as cakes and whole vegetables. Roasts need this time to complete cooking in the center without overcooking the outer areas. All liquids, such as soup or hot chocolate, should be shaken or stirred when cooking is complete. Let liquids stand a moment before serving. When heating baby food, stir well at removal and test the temperature before serving.

ADDING MOISTURE

Microwave energy is attracted to water molecules. Food that is uneven in moisture content should be covered or allowed to stand so that the heat disperses evenly. Add a small amount of water to dry food to help it cook.

SPECIFICATIONS

Power Consumption:	120V~60Hz, 1500W (Microwave)
Output:	1250W
Operation Frequency:	2450MHz
Outside Dimensions (HxWxD):	14 13/16×24 3/4×19 5/8 in.
Oven Cavity Dimensions (HxWxD):	11 9/16×18 7/16×18 11/16 in.
Oven Capacity:	2.2 cu.ft
Cooking Uniformity:	Turntable System
Net Weight:	Approx. 37lb.

PART NAMES

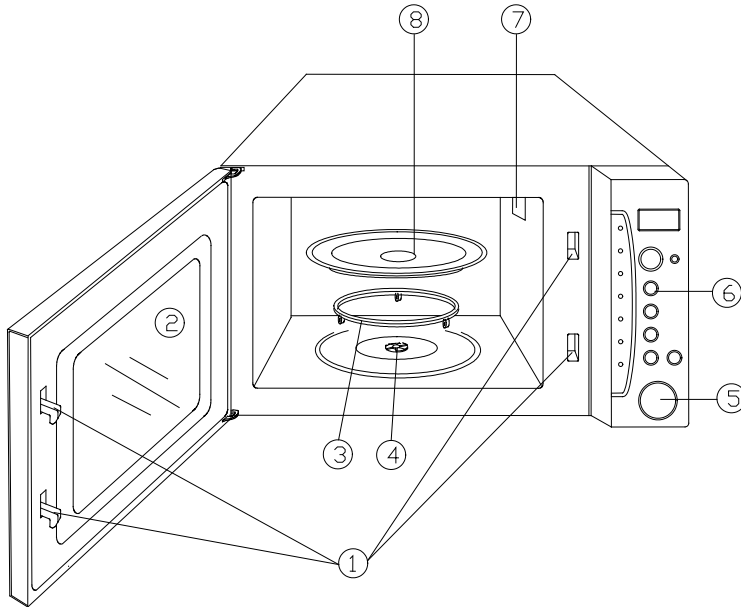

1. Door Safety Lock System
2. Oven Window
3. Roller Ring
4. Shaft
5. Door Release Button
6. Control Panel
7. Wave Guide
8. Glass Tray

CONTROL PANEL

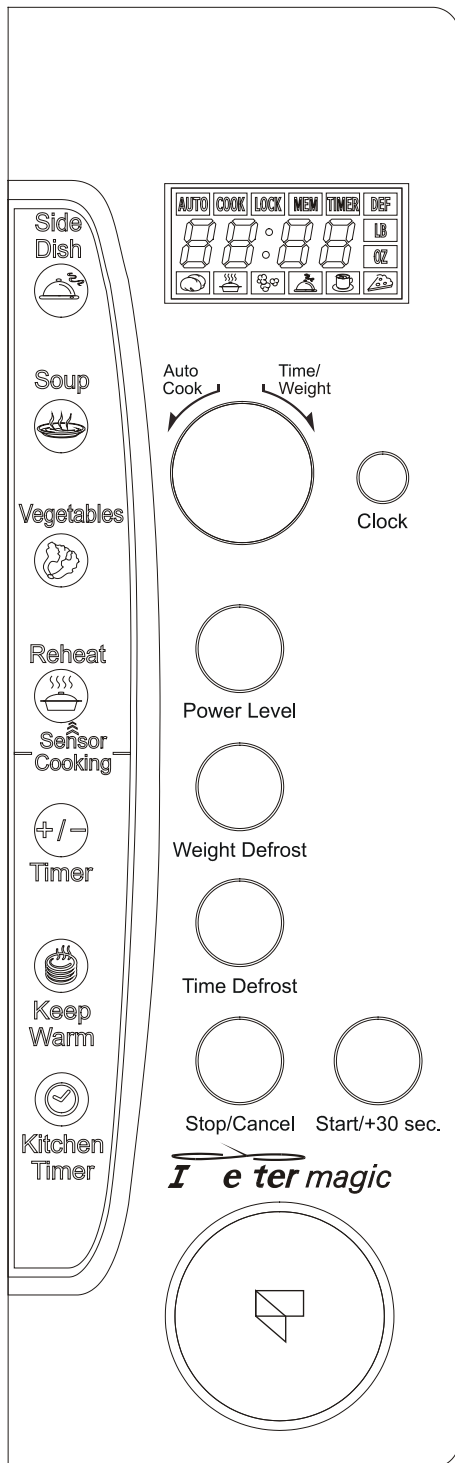

- MENU ACTION SCREEN

Cooking time, power, indicators and present time are displayed.

- POWER LEVEL

Use to set microwave power levels.

- CLOCK

Touch to set CLOCK function.

- KITCHEN TIMER

Touch to set timer function.

- KEEP WARM

Touch to set keep warm program.

- STOP/CANCEL

Touch to stop the oven or reset the oven before setting a program.

Touch to set the SAFETY LOCK

- WEIGHT DEFROST.

Use to set weight defrost program.

- TIME DEFROST

Touch to set defrost program base on the time

- START/+30SEC.

Touch to start the oven; also use to add cooking time during cooking process and use to set the express cooking.

- TIMER +/-

use to change cooking time during cooking process

- AUTO COOK/TIME/WEIGHT DIAL

use to choose auto menu code; also use to select time or weight.

OPERATION INSTRUCTIONS

SETTING THE CLOCK

This is a clock in 12 or 24 hour cycle. Suppose you want to enter 8:08.

1. In standby mode, touch CLOCK pad once, "HR:12" is displayed. If you want to set the clock in 24-hour cycle, touch CLOCK again, "HR:24" will be displayed.
2. Turn AUTO COOK/TIME/WEIGHT DIAL to indicate the hour digit 8.
3. Press CLOCK button once.
4. Turn AUTO COOK/TIME/WEIGHT DIAL to indicate the minute digits until the screen shows 8: 08.
5. Press START/+30SEC to confirm the setting.

Note: During cooking, you can press CLOCK pad to check the clock.

MICROWAVE COOKING

The longest cooking time is 95 minutes.

Select power level by pressing the POWER LEVEL button:

Press POWER LEVEL button	COOKING POWER	DISPLAY
once	100%	P100
twice	90%	P-90
3 times	80%	P-80
...
9 times	20%	P-20
10 times	10%	P-10

Suppose you want to cook for 5 minutes at 60%:

1. The default setting is 100% microwave power output. If you want to set a power level other than 100%, touch POWER LEVEL pad to select the power level.
2. Turn AUTO COOK/TIME/WEIGHT DIAL to enter 5 minutes
3. Press START/+30SEC. pad to start.

NOTE:

1. You can check power level during cooking by pressing POWER LEVEL pad.
2. For default power level(100%),you may omit step 1
3. During the cooking process, you click " START/+30SEC. " key once, can increase 30 seconds of cooking time. The longest cooking time is 95 minutes

EXPRESS COOK

In standby mode, press START/+30SEC pads to enter cooking time, and the oven will start automatically at 100% high power level. During cooking, you can add the cooking time by pressing START/+30SEC. pad.

ADJUST THE COOKING TIME

During cooking process (except the auto menu cook), you may press TIMER +/- pad once and then turn the AUTO COOK/TIME/WEIGHT DIAL to extend or shorten the cooking time while the sign COOK is twinkling for 10 seconds

KEEP WARM

1. In standby mode, press KEEP WARM pads once
2. Turn AUTO COOK/TIME/WEIGHT DIAL to enter desired time. The longest cooking time is 95 minutes.
3. Press START/+30SEC. pad to confirm.

SETTING THE TIMER

The countdown longest time is 95 minutes

1. Press TIMER pad.
2. Turn AUTO COOK/TIME/WEIGHT DIAL to enter time. The longest cooking time is 95 minutes.
3. Press START/+30SEC.pad to confirm.

NOTE:

1. If you want to cancel the timer, press TIMER pad, during the display showing the time, press STOP/CANCEL pad.
2. When the countdown ends, the buzzer will beep to remind you.
3. During sensor cooking, the timer program cannot be set and check.
4. Once you set the timer in standby mode, you can not set the cook program at the countdown time

TIME DEFROST

The longest defrosting time is 95 minutes

1. Touch TIME DEFROST pad once.
2. Enter desired defrosting time by turning AUTO COOK/TIME/WEIGHT DIAL.
3. Touch START/+30SEC pad.

WEIGHT DEFROST

The oven could be used to defrost food on the weight you entered. The defrosting time and power level are automatically set once the weight is programmed.

FOR EXAMPLE: Suppose you want to defrost food.

1. Press STOP/CANCEL pad to reset the oven.
2. Press WEIGHT DEFROST pad once.
3. Enter weight by turning AUTO COOK/TIME/WEIGHT DIAL. The maximum weight is 6 LB.16 OZ.
4. Press START/+30SEC pad.

NOTE: During defrosting process, the system will pause to remind user to turn food over, after that,

press START/+30SEC to resume.

MULTIPLE COOKING

The microwave oven can set 3 period of microwave cooking program
Suppose you want set the following cooking program:

Paragraph 1: Microwave and power level cooking (2 minutes at 100%);

Paragraph 2: Microwave and power level cooking (5 minutes at 60%);

1. Press STOP/CANCEL pad to reset the oven.

Paragraph 1:

2. Touch POWER pad to select "P100" power level.
3. Turn AUTO COOK/TIME/WEIGHT DIAL to enter cooking time "2:00".

Paragraph 2:

4. Touch POWER pad and then use the number pads 6 to select "P60" power level.
5. Turn AUTO COOK/TIME/WEIGHT DIAL to enter cooking time "5:00".
6. Press START/+30SEC. pad to start.

SENSOR COOK

The sensor features detect the increasing humidity released during cooking. The oven automatically adjusts the cooking time to various types and amounts of food.

Suppose you want to cook potatoes:

1. Place the food in the oven and close the door, press desired sensor menu pads once to enter menu code, the oven will start automatically. (Beeps will sound to signal error operation if door is opened.)
 2. Error may occur to the system sensor or else, in this case, the system will stop automatically with the display showing E0, beeps sound until STOP/CANCEL is pressed.
 3. When steam is sensed, corresponding cooking time appears on display and begins counting down.
- You can adjust the cooking time by using the TIMER +/- pad. To Turn or stir food if necessary.

SENSOR COOKING CHART

Food	Food Code	Food	REMARK
Reheat 	SR-1	Beverage	7 minutes without induction cooking over
	SR-2	Casserole	6 minutes without induction cooking over
	SR-3	Plate of Food	6 minutes without induction cooking over
	SR-4	Steak	5 minutes without induction cooking over
Vegetables 	SE-1	Fresh	8 minutes without induction turn P-60 2:00
	SE-2	Frozen	10 minutes without induction turn P-60 2:00
	SE-3	Canned	5 minutes without induction cooking over
Side Dishes 	SS-1	Potato	15 minutes without induction cooking over
	SS-2	Rice	10 minutes without induction turn P-20 20:00
	SS-3	Pasta	15 minutes without induction cooking over
Soup 	SOUP	Soup	8 minutes without induction cooking over

NOTE:

1. During cooking process, you may press TIMER +/- pad once and then turn the dial to extend or shorten the cooking time (each for 15 seconds) while the sign COOK is twinkling
2. If you open the oven door or press STOP/CANCEL during cooking, the system returns to standby mode immediately.
3. Do not use the sensor features twice in succession on the same food portion— it may result in severely overcooked or burnt food. If food is undercooked after the countdown, use time cooking for additional cooking time.
4. For Beverage and popcorn cooking, you can stop the oven by pressing STOP/CANCEL pad or open the door. For Beverage, press number pad 1 or 2 to select number of servings before starting the oven.





AUTO COOK

For food or the following cooking mode, it is not necessary to program the duration and the cooking power. It is sufficient to indicate the type of food that you wish to cook as well as the weight of this food. You may need to turn food over at the middle of cooking time to obtain uniform cooking.

For example: to cook 1/2 Stick of Butter.

1. In waiting mode, place food into oven, and close the door.
2. Turn AUTO COOK/TIME/WEIGHT DIAL anti-clockwise once and rotate until code B1 displays.
3. Press CLOCK/WEIGHT to indicate a weight of 400g.
4. Press START/+30SEC to start.

Auto Cook Menu

Food	Food Code	Weight	POWER	TIME
Butter 	B1	1/2 Stick	P-20	0:20
	B2	1 Stick		0:30
	B3	2 Stick		0:40
Cheese 	C1	3 ounce	P-20	0:20
	C2	6 ounce		0:30
Frozen Pizza (4 ounce each) 	F1	1 slice	P-100	0:40
	F2	2 slice		1:00
	F3	3 slice		1:50
Ice Cream 	E1	1 pint	P-20	0:40
	E2	1 quart		1:00
Popcorn 	P1	1.75 ounce	P-100	1:30
	P2	3.0 ounce		1:50
	P3	3.5 ounce		2:00

CHILD LOCK

Use to prevent unsupervised operation of the oven by little children. The Child Lock indicator will show on display screen, and the oven can not be operated while the Child Lock is set.

To set: In standby mode, press and hold the STOP/CANCEL button for 3 seconds, a beep sounds and lock indicator lights.

To cancel: Press and hold the STOP/CANCEL button for 3 seconds until lock indicator light on display turns off.

CLEANING AND CARE

1. Turn off the oven and remove the power plug from the wall socket before cleaning.
2. Keep the inside of the oven clean. When food splatters or spilled liquids adhere to oven walls, wipe with a damp cloth. Mild detergent may be used if the oven gets very dirty. Avoid the use of spray and other harsh cleaners as they may stain, streak or dull the door surface.
3. The outside surfaces should be cleaned with a damp cloth. To prevent damage to the operating parts inside the oven, water should not be allowed to seep into the ventilation openings.
4. Wipe the window on both sides with a damp cloth to remove any spills or splatters.
5. Do not allow the control panel to become wet. Clean with a soft, damp cloth. When cleaning the control panel, leave oven door open to prevent oven from accidentally turning on.
6. If steam accumulates inside or around the outside of the oven door, wipe with a soft cloth. This may occur when the microwave oven is operated under high humidity conditions. In such case, it is normal.
7. It is occasionally necessary to remove the glass tray for cleaning. Wash the tray in warm sudsy water or in a dishwasher.
8. The roller ring and oven floor should be cleaned regularly to avoid excessive noise. Simply wipe the bottom surface of the oven with mild detergent. The roller ring may be washed in mild sudsy water or dishwasher. When removing the roller ring from cavity floor for cleaning, be sure to replace in the proper position.
9. Remove odors from your oven by combining a cup of water with the juice and skin of one lemon in a deep microwaveable bowl, microwave for 5 minutes. Wipe thoroughly and dry with a soft cloth.
10. When it becomes necessary to replace the oven light, please consult a dealer to have it replaced.
11. The oven should be cleaned regularly and any food deposits removed. Failure to maintain the oven in a clean condition could lead to deterioration of the surface that could adversely affect the life of the appliance and possibly result in a hazardous situation.
12. Please do not dispose this appliance into the domestic rubbish bin, it should be disposed to the particular disposal center provided by the municipalities.