

INSTRUCTION'S MANUAL

Microwave Oven

Model No.P9023AP-BM1

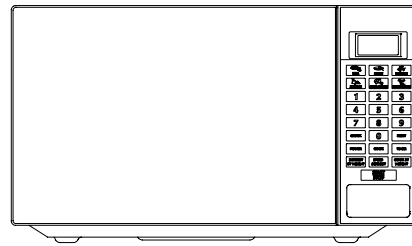

CAUTION:
Carefully Read
Instructions and
Procedures for
Safe Operation

Date of Purchase:
____/____/____

UPC CODE:
836321002450

Please save your original receipt as proof of purchase for warranty service

PRECAUTIONS TO AVOID POSSIBLE EXPOSURE TO EXCESSIVE MICROWAVE ENERGY

- (a) Do not attempt to operate this oven with the door-open since open-door operation can result in harmful exposure to microwave energy. It is important not to defeat or tamper with the safety interlocks.
- (b) Do not place any object between the oven front face and the door or allow soil or cleaner residue to accumulate on sealing surfaces.
- (c) Do not operate the oven if it is damaged. It is particularly important that the oven door close properly and that there is no damage to the :
 - ① Door (bent),
 - ② Hinges and latches (broken or loosened),
 - ③ Door seals and sealing surfaces.
- (d) The oven should not be adjusted or repaired by anyone except properly qualified service personnel.

CONTENTS

IMPORTANT SAFETY INSTRUCTIONS.....	2
GROUNDING INSTRUCTIONS	3
UTENSILS GUIDE	4
COOKING TECHNIQUES	6
BEFORE YOU CALL FOR SERVICE	7
SPECIFICATIONS	7
PART NAMES.....	7
CONTROL PANEL.....	8
HOW TO SET THE OVEN CONTROLS.....	9
SPECIAL FEATURES.....	13
CLEANING AND CARE	17

IMPORTANT SAFETY INSTRUCTIONS

When using electrical appliances, basic safety precautions should be followed, including the following:

WARNING - To reduce the risk of burns, electric shock, fire, injury to persons or exposure to excessive microwave energy:

1. Read all instructions before using the appliance.
2. Read and follow the specific "PRECAUTIONS TO AVOID POSSIBLE EXPOSURE TO EXCESSIVE MICROWAVE ENERGY" on page 1.
3. This appliance must be grounded. Connect only to properly grounded outlet. See "grounding instructions" on page 3.
4. Install or locate this appliance only in accordance with the provided installation instructions.
5. Some products such as whole eggs and sealed containers -for example, closed glass jars- are able to explode and should not be heated in this oven.
6. Use this appliance only for its intended use as described in this manual. Do not use corrosive chemicals or vapors in this appliance. This type of oven is specifically designed to heat, cook, or dry food. It is not designed for industrial or laboratory use.
7. As with any appliance, close supervision is necessary when used by

children.

8. To reduce the risk of fire in the oven cavity:

- a. Do not overcook food. Carefully attend appliance when paper, plastic, or other combustible materials are placed inside the oven to facilitate cooking.
- b. Remove wire twist-ties from paper or plastic bags before placing bag in oven.
- c. If materials inside the oven should ignite, keep oven door closed, turn oven off, and disconnect the power cord or shut off power at the fuse or circuit breaker panel.
- d. Do not use the cavity for storage purposes. Do not leave paper products, cooking utensils or food in the cavity when not in use.

9. Liquids, such as water, coffee, or tea are able to be overheated beyond the boiling point without appearing to be boiling due to surface tension of the liquid. Visible bubbling or boiling when the container is removed from the microwave oven is not always present. **THIS COULD RESULT IN VERY HOT LIQUIDS SUDDENLY BOILING OVER WHEN A SPOON OR OTHER UTENSIL IS INSERTED INTO THE LIQUID.** To reduce the risk of injury to person:

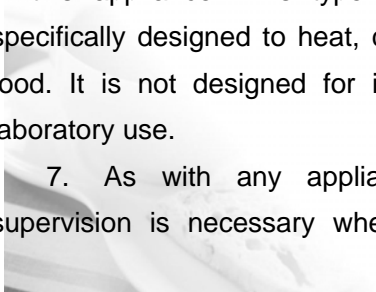

- a. Do not overheat the liquid.
 - b. Stir the liquid both before and halfway through heating it.
 - c. Do not use straight-sided containers with narrow necks.
 - d. After heating, allow the container to stand in the microwave oven for a short time before removing the container.
 - e. Use extreme care when inserting a spoon or other utensil into the container.
10. Do not heat oil or fat for deep-frying. It is difficult to control the temperature of oil in microwave oven.
 11. Pierce foods with heavy skins such as potatoes, whole squash, apples and chestnuts before cooking.
 12. The contents of feeding bottles and baby jars should be stirred or shaken and the temperature should be checked before serving in order to avoid burns.
 13. Cooking utensils may become hot because of heat transferred from the heated food. Potholders may be needed to handle the utensil.
 14. Do not cover or block any openings on the appliance.
 15. Do not store or use this appliance outdoors. Do not use this product near water, for example, near a kitchen sink, in a wet basement, near a swimming pool, or

similar locations.

16. Do not operate this appliance if it has a damaged cord or a plug, if it is not working properly or if it has been damaged or dropped.

17. Do not immerse cord or plug in water. Keep cord away from heated surface. Do not let cord hang over edge of table or counter.

18. Use only thermometers, which are specifically designed for use in microwave ovens.

19. Do not operate any heating or cooking appliance beneath this appliance.

20. Be certain the glass tray and roller rings are in place when you operate the oven.

21. **WARNING:** It is hazardous for anyone other than a trained person to carry out any service or repair operation which involves the removal of any cover which gives protection against exposure to microwave energy. If there is any damage, do not operate the oven and contact your dealer.

22. When cleaning surfaces of door and oven that comes together on closing the door, use only mild, nonabrasive soaps, or detergents applied with a sponge or soft cloth.

GROUNDING INSTRUCTIONS

This appliance must be grounded. In the event of an electrical short circuit, grounding reduces risk of electric shock by providing an escape wire for the electric current.

SAVE THESE INSTRUCTIONS

WARNING: Improper use of the grounding plug can result in a risk of electric shock.

Electrical Requirements

The electrical requirements are a 120 volt 60 Hz, AC only, 20 amp. It is recommended that a separate circuit serving only the oven be provided. The oven is equipped with a 3-prong grounding plug. It must be plugged into a wall receptacle that is properly installed and grounded.

Power Supply Cord

1. A short power supply cord is provided to reduce the risks resulting from becoming entangled in or tripping over a longer cord.
2. Longer cord sets or extension cords are available and may be used if care is exercised in their use.
3. If long cord or extension cord is used:
 - a) The marked electrical rating of the cord set or extension cord should be at least as great as the electrical rating of the appliance.
 - b) The extension cord must be a grounding-type 3-wire cord, and The longer cord should be arranged so that it will not drape over the counter top or table top where it can be pulled on by children or tripped over unintentionally.

Notes:

If you have any questions about the grounding or electrical instructions, consult a qualified electrician or service person.

Neither SYLVANIA nor the dealer can accept any liability for damage to the oven or personal injury resulting from failure to observe the electrical connection procedures.

UTENSILS GUIDE

This section lists which utensils can be used in the microwave, which ones have limited use for short periods, and which ones should not be used in the microwave.

Recommended

- **Microwave browning dish** — Use to brown the exterior of small items such as steaks, chops, or pancakes. Follow the directions provided with your browning dish.
- **Microwaveable plastic wrap** — Use to retain steam. Leave a small opening for some steam to escape and avoid placing it directly on the food.

SAVE THESE INSTRUCTIONS



- **Paper towels and napkins** — Use for short-term heating and covering; these absorb excess moisture and prevent spattering. Do not use recycled paper towels, which may contain metal and could ignite.
- **Glass and glass-ceramic bowls and dishes** — Use for heating or cooking.
- **Paper plates and cups** — Use for short-term heating at low temperatures. Do not use recycled paper, which may contain metal and could ignite.
- **Wax paper** — Use as a cover to prevent spattering.
- **Thermometers** — Use only those labeled “Microwave Safe” and follow all directions. Check the food in several places. Conventional thermometers may be used on microwave food once the food has been removed from the oven.

Limited Use

- **Aluminum foil** — Use narrow strips of foil to prevent overcooking of exposed areas. Using too much foil can damage your oven, so be careful.
- **Ceramic, porcelain, and stoneware** — Use these if they are labeled “Microwave Safe”. If they are not labeled, test them to make sure they can be used safely.
- **Plastic** — Use only if labeled “Microwave Safe”. Other plastics can melt.
- **Straw, wicker, and wood** — Use only for short-term heating, such as warming dinner rolls for a few seconds; baskets and bowls may be flammable.

Not Recommended

- **Glass jars and bottles** — Regular glass is too thin to be used in a microwave. It can shatter and cause damage and injury.
- **Paper bags** — These are a fire hazard, except for popcorn bags that are designed for microwave use.
- **Styrofoam plates and cups** — These can melt and leave an unhealthy residue on food.
- **Plastic storage and food containers** — Containers such as margarine tubs can melt in the microwave.
- **Metal utensils** — These can damage your oven. Remove all metal before cooking.

Note: Should you wish to check if a dish is safe for microwaving, place the empty dish in the oven and microwave on HIGH for 30 seconds. A dish which becomes very hot should not be used.

SAVE THESE INSTRUCTIONS



COOKING TECHNIQUES

Your microwave makes cooking easier than conventional cooking, provided you keep these considerations in mind:

Stirring

Stir foods such as casseroles and vegetables while cooking to distribute heat evenly. Food at the outside of the dish absorbs more energy and heats more quickly, so stir from the outside to the center. The oven will turn off when you open the door to stir your food.

Arrangement

Arrange unevenly shaped foods, such as chicken pieces or chops, with the thicker, meatier parts toward the outside of the turntable where they receive more microwave energy. To prevent overcooking, place delicate areas, such as asparagus tips, toward the center of the turntable.

Shielding

Shield food with narrow strips of aluminum foil to prevent overcooking. Areas that need shielding include poultry wing-tips, the ends of poultry legs, and corners of square baking dishes. Use only small amounts of aluminum foil. Larger amounts can damage your oven.

Turning

Turn foods over midway through cooking to expose all parts to microwave energy. This is especially important with large foods such as roasts.

Standing

Foods cooked in the microwave build up internal heat and continue to cook for a few minutes after heating stops. Let foods stand to complete cooking, especially foods such as cakes and whole vegetables. Roasts need this time to complete cooking in the center without overcooking the outer areas. All liquids, such as soup or hot chocolate, should be shaken or stirred when cooking is complete. Let liquids stand a moment before serving. When heating baby food, stir well at removal and test the temperature before serving.

Adding moisture

Microwave energy is attracted to water molecules. Food that is uneven in moisture content should be covered or allowed to stand so that the heat disperse evenly. Add a small amount of water to dry food to help it cook.



SAVE THESE INSTRUCTIONS

BEFORE YOU CALL FOR SERVICE

If the oven fails to operate:

- A) Check to ensure that the oven is plugged in securely. If it is not, remove the plug from the outlet, wait 10 seconds and plug it in again securely.
- B) Check for a blown circuit fuse or a tripped main circuit breaker. If these seem to be operating properly, test the outlet with another appliance.
- C) Check to ensure that the control panel is programmed correctly and the timer is set.
- D) Check to ensure that the door is securely closed engaging the door safety lock system. Otherwise, the microwave energy will not flow into the oven.

IF NONE OF THE ABOVE RECTIFY THE SITUATION, THEN CONTACT A QUALIFIED TECHNICIAN. DO NOT TRY TO ADJUST OR REPAIR THE OVEN YOURSELF.

SPECIFICATIONS

Power Consumption:	120V, 60Hz, 1350W (Microwave)
Rated Microwave Output:	900W
Operation Frequency:	2450MHz
Outside Dimensions:	20(W)x15 15/16 (D) x 12 (H) in
Oven Cavity Dimensions:	13 3/4 (W)x13 (D) x 8 7/16 (H) in
Oven Capacity:	0.9 cu.ft
Net Weight:	Approx. 34.4 lbs

PART NAMES

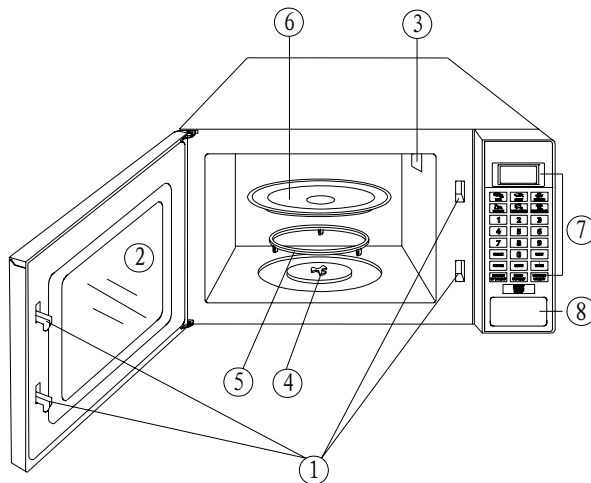

- 1. Door Safety Lock System
- 2. Oven Window
- 3. Oven Air Vent
- 4. Shaft
- 5. Roller Ring
- 6. Glass Tray
- 7. Control Panel
- 8. Door Release Button

CONTROL PANEL



(Please see the following pages for more detail)

DISPLAY SCREEN

Cooking time, power, indicators and present time are displayed.

QUICK COOK

POPCORN BEVERAGE
POTATO FROZEN DINNER
PIZZA REHEAT

Allow you to reheat or cook food automatically without entering power level or time.

POWER

Use to set power level.

TIMER

You can use the TIMER function independently, even while a cooking program is going on in the oven.

COOK

Cook at one power level for a period of time, then the oven automatically switches to another power level for the rest of cooking time.

DEFROST BY WEIGHT

Touch to set the weight of the food to be defrosted; the oven automatically sets the defrosting time and power level.

COOK BY WEIGHT

Touch to enter weight of meat accurately. The oven automatically sets the cooking time and power level.

SPEED DEFROST

Touch to set defrosting time; the oven automatically divides the defrosting time into periods of alternating defrost and stand times by cycling on and off.

NUMBER PADS(0-9)

Touch to set times or amounts.

CLOCK

Touch to set the clock.

RESET

Clears all previous settings if touched before cooking starts.

START/STOP

Touch to start or stop cooking.

HOW TO SET THE OVEN CONTROLS

BEEPS DURING OVEN SETTINGS

- ◆ ONE BEEP: Oven accepts the entry.
- ◆ TWO BEEPS: Oven does not accept the entry. Please check and try again.

SETTING THE CLOCK

When the oven is first plugged in, the display will briefly show “ENTER CLOCK TIME”, you can set the clock time now or later. To set the clock time later,



1. Press CLOCK pad.

2. Use the numeric pads (in the natural sequence of time) to enter clock time.

3. Press CLOCK to confirm.

NOTE: ①The clock works in 12-hour cycle.

②If you make a mistake when setting the time, touch the RESET pad.

The display stops blinking, and the colon starts blinking. This digital clock allows you to set from 1:00 to 12:59.

MICROWAVE COOKING

A. One-stage Cooking

1. Press number pads to enter cooking time until the correct cooking time is displayed.

2. Press POWER pad.



(Select the desired power level by touch the numeric pads.)

3. Press START/STOP pad.

The display will show entered cooking time.

The “COOK” indicator lights

The display will show the entered power level.

NOTE: ① If steps 2 is omitted, the oven will cook at full power.

NOTE: ② Your oven can be programmed for 99 minutes 99 seconds.(99:99)

③ Touch the RESET pad or open the door to clear before starting another operation.

Microwave cooking allows you to customize cooking power and time. First, you select a power level by pressing the POWER pad and numeric pads (see the table below). Then you set the cooking time using the numeric pads, before pressing the START pad.

Press Number pads to select cooking power		
Press	Power	Description
Power	100%(100)	High
9	90%(90)	
8	80%(80)	
7	70%(70)	Medium High
6	60%(60)	
5	50%(50)	Medium
4	40%(40)	
3	30%(30)	Med. Low / Defrost
2	20%(20)	
1	10%(10)	Low

B. Two-stage Cooking

Some recipes require different stages of cooking at different cooking powers.

1. SET STAGE 1:

Follow steps 1 and 2 in “One-stage Cooking”.

NOTE: Do not touch START/STOP pad.

2. SET STAGE 2:

Touch COOK pad then enter proper cooking time and (lower) power level.

NOTE: Most 2-stage recipes use lower power

3. Press START/STOP pad.



SETTING “COOK BY WEIGHT”



1. Press COOK BY WEIGHT.

“ENTER”, “CODE” indicators light.

2. Enter the one-digit code by touching the correct number pad.

Cook By Weight Code Description

Code	Type	Max Weight
1	Beef	5 lb. 16 oz.
2	Mutton	5 lb. 16 oz.
3	Pork	5 lb. 4 oz.

3. Press number pads to enter weight.

The display shows entered weight.

4. Touch START/STOP Pad.

The display counts down the cooking time.

Converting Fractions of a Pound to Ounces

Fractions of a pound	Ounces
Less than .03	0
.03 to .09	1
.10 to .15	2
.16 to .21	3
.22 to .27	4
.28 to .34	5
.35 to .40	6
.41 to .46	7
.47 to .53	8
.54 to .59	9
.60 to .65	10
.66 to .71	11
.72 to .78	12
.79 to .84	13
.85 to .90	14
.91 to .97	15
Above .97	Go to next even

NOTE:

1. Meat must be defrosted and at refrigerated temperature.
2. Weight must be in pounds and ounces.
3. Ounce weights less than 10 must be preceded by a 0. If label gives weight in pounds only, change the fraction of a pound to ounces using the left chart.
4. Turn meat over when oven signals twice. Touch START/STOP to resume cooking.
5. After total cooking time, 4 signals sound and END appears in display. Touch RESET or open oven door to clear END before starting another cooking function.
6. Let meat stand few minutes before carving.

SETTING “DEFROST BY WEIGHT”

1. Touch DEFROST BY WEIGHT pad. “ENTER”, “LB” indicator light and “ 0 “ is displayed.



2. Press number pads to enter weight. The display shows entered weight.

3. Touch START/STOP pad.

NOTE: 1. Weight must be in pounds and ounces. Ounce weights less than 10 must be preceded by a 0. If label gives weight in pounds only, change the fraction of a pound to ounces using the chart on this page.

2. Turn food over when oven beep twice. Touch START/STOP pad to resume defrosting.

3. After total defrosting time, 4 beeps sound and END appears in display. Touch RESET or open oven door to clear END before starting another cooking function.

SETTING “SPEED DEFROST”

1. Touch SPEED DEFROST pad. "ENTER" 、 "DEF" 、 "TIME" indicators light and “ : ” is displayed.



2. Press number pads to enter time. The display shows the entered time.

3. Touch START/STOP pad.

NOTE:

1. After time has elapsed four beeps sound and END appears in display. Touch RESET pad or open door to clear END before starting another cooking function.

2. After setting SPEED DEFROST, oven can be programmed to automatically switch to one or two-Stage cooking.

A. For defrost by time and one stage cooking, follow steps above. Before touching START/STOP pad, touch COOK pad, enter time and power level. Then touch START/STOP pad.

B. For defrost by time and two stage cooking, follow steps above. Before touching START/STOP pad, enter two-stage cooking programs.

SPECIAL FEATURES

In this special feature section, you can find easy settings to cooking popular food.

POPCORN

This feature allows a regular sized bag (99g or approximately 3.5oz) of popcorn to be popped.

1. Press POPCORN pad once.



preprogrammed cooking time "2:00" is displayed.

Cooking time is counted down.

2. Press START/STOP pad.

NOTE: 1. Popping time can vary from 2~4 minutes according to brand of popcorn. 2. To reset POPCORN time: 1) Tap POPCORN pad twice. 2) Touch number pads to enter minutes and seconds. 3) Touch START/STOP pad. This new cooking time will remain whenever you touch the POPCORN pad until you reset it.

CAUTION: Do not place bag directly on the turntable tray, place bag on microwavable dish when cooking.

POTATO

For 3.5~5 oz. potatoes:

1. Touch POTATO pad once.



"ENTER", "AMT" indicators light.

2. Enter number of potatoes by number pad 1~4
3. Press START/STOP pad.

The display will show the entered weight.

Preprogrammed cooking time is displayed and counted down.

For 6~8 oz. potatoes:

1. Touch POTATO pad twice.



"ENTER", "AMT" indicators light.

2. Enter number of potatoes by number pad 1~4.
3. Press START/STOP pad.

The display will show the entered weight.

Preprogrammed cooking time is displayed and counted down.

BEVERAGE

For 5~7oz. coffee cups:

1. Touch BEVERAGE pad once.

“ENTER”, “AMT” indicators light.



2. Enter number of cups by number pad 1~4.
3. Press START/STOP pad.

Display shows total cooking weight.

Cooking time displayed and counted down the time remaining.

For 9~11 oz. coffee cups:

1. Touch BEVERAGE pad twice.

“ENTER”, “AMT” indicators light.



2. Enter number of cups by number pad 1~4.
3. Press START/STOP pad.

Display shows total cooking weight.

Cooking time displayed and counted down the time remaining.

FROZEN DINNER

For 7~9 oz. per entree:

1. Touch FROZEN DINNER pad once.

“ENTER”, “AMT” indicators light.



2. Enter number of cups by number pad 1~2.
3. Press START/STOP pad.

The display will show the entered weight.

Preprogrammed cooking time is displayed and counted down.



For 10~12oz. per entree:

1.Touch FROZEN DINNER pad twice.



2.Enter number of cups by number pad
1~2.
3.Press START/STOP pad.

“ENTER”, “AMT” indicators light.

The display will show the entered weight.

Preprogrammed cooking time is displayed and counted down.

REHEAT

1. Press REHEAT pad



2. Press START/STOP pad.

“CODE” indicator lights and preprogrammed cooking time “3:15” is displayed.

NOTE: Touch the reheat pad will allow the reheating of a chilled dinner plate.

Preprogrammed cooking time is counted down.

PIZZA

Reheating a slice of pizza.

1. Press PIZZA pad



2. Press START/STOP pad.

“CODE” indicator lights and preprogrammed cooking time “1:00” is displayed.

Preprogrammed cooking time is counted down.

Reheating a whole pizza.

1. Press PIZZA pad



2. Press START/STOP pad.

“CODE” indicator lights and preprogrammed cooking time “5:00” is displayed.

Preprogrammed cooking time is

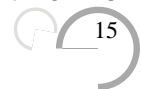

counted down.

OTHER CONVENIENT FEATURES

MINUTE TIMER

The timer works independently as a reminder and the time countdown ends in beeping.

1. Press TIMER pad.



“ENTER”, “TIMER”, “TIME” indicators light and “:” will be displayed.

2. Use the numeric pads to enter the time to be counted down.
3. Press START/STOP pad.

The display will show the entered time.

NOTE: Touch the TIMER pad followed by the RESET pad to cancel the timer.

CHILD SAFETY LOCK



The lock prevents unsupervised operation by little children. To set the lock: Press RESET pad for 3 seconds, then a beep will sound and the “LOCK” indicator light will come on. In the lock state, all pads are disabled.

To cancel the lock: Press RESET pad for 3 seconds, then a beep will sound and the indicator light will come off.

TO STOP THE OVEN WHILE THE OVEN IS OPERATING

1. Press START/STOP pad.



NOTE: You can restart the oven by pressing START/STOP pad. Touch RESET to erase all instructions.

2. Open the door.

NOTE: You can restart the oven by closing the door and pressing START/STOP pad.

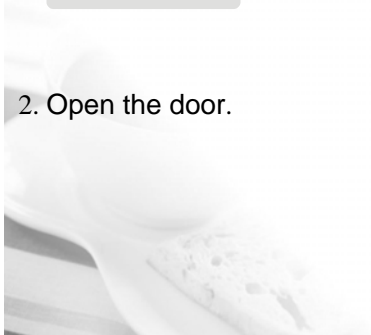

CLEANING AND CARE

1. Turn off the oven and remove the power plug from the wall socket before cleaning.
2. Keep the inside of the oven clean. When food splatters or spilled liquids adhere to oven walls, wipe with a damp cloth. Mild detergent may be used if the oven gets very dirty. Avoid the use of spray and other harsh cleaners as they may stain, streak or dull the door surface.
3. The outside surfaces should be cleaned with a damp cloth. To prevent damage to the operating parts inside the oven, water should not be allowed to seep into the ventilation openings.
4. Wipe the window on both sides with a damp cloth to remove any spills or spatters.
5. Do not allow the control panel to become wet. Clean with a soft, damp cloth. When cleaning the control panel, leave oven door open to prevent oven from accidentally turning on.
6. If steam accumulates inside or around the outside of the oven door, wipe with a soft cloth. This may occur when the microwave oven is operated under high humidity conditions, this is normal.
7. It is occasionally necessary to remove the glass tray for cleaning. Wash the tray in warm sudsy water or in a dishwasher.
8. The roller ring and oven floor should be cleaned regularly to avoid excessive noise. Simply wipe the bottom surface of the oven with mild detergent. The roller ring may be washed in mild sudsy water or dishwasher. When removing the roller ring from cavity floor for cleaning, be sure to replace in the proper position.
9. Remove odors from your oven by combining a cup of water with the juice and skin of one lemon in a deep bowl, microwave for 5 minutes. Wipe thoroughly and dry with a soft cloth.
10. When it becomes necessary to replace the oven light, please consult a dealer to have it replaced.

WARRANTY

Galanz Warrants this product to be free from manufacturing defects in material and workmanship under normal use for a period of ONE YEAR from date of purchase. For service, technical and warranty coverage details, please contact us at 1-800-856-8977.

This warranty is void if:

- Used in a commercial application or rental
- Damaged through misuse, negligence or abuse
- Modified or repaired by anyone other than a qualified service technician
- Damaged because it is improperly connected to any other equipment

This warranty does not cover:

- Ordinary adjustments as outlined in the owner's manual which can be performed by the customer (if applicable)
- Damage to equipment not properly connected to the product
- Any cost incurred in shipping the product for repair
- Damage to product not used in USA
- Possible incompatibility with other systems
- Signal reception problems caused by external antenna or cable systems
- Or any damage caused by flood, fire, accidents, or Acts of God.

This warranty is not transferable and only applies to the original purchase. Any implied warranties, including the warranty of merchantability, are limited in duration to the period of this expressed warranty and no warranty whether expressed or implied shall apply to the product thereafter. Under no circumstance shall Galanz, or the retailer of this product, be liable for any loss or consequential damage arising out of the use of the product. This warranty gives specific legal rights. However, you may have other rights, which may vary from state to state. Some states do not allow limitations on implied warranties or exclusions of consequential damage. Therefore, these restrictions may not apply.

REGISTRATION: PLEASE COMPLETE AND RETAIN FOR WARRANTY PURPOSES

Visit us on the web at: www.galanz.com

Please save your original receipt as proof of purchase for warranty service.

FCC Warning statement:

The Device complies with part 18 of the FCC rules, Operation is subject to the following conditions: (1) This device may not cause harmful interference, and (2) this device must accept any interference received, including interference that may cause undersired operation

This device complies with Part 18 of the FCC Rules. This device may cause interference to radio and TV receivers. If interference is experienced, you can determine if this microwave oven is causing the interference by turning it off and on. To eliminate interference, move the receiver farther from the micro-wave oven or plug the receiver into a different AC outlet than the microwave oven.