

**HIGH SPECIFICATION DATA TRANSCEIVER**  
**PART NO. 242-3474-XX0**

Second Printing  
August 1998

Part No. 001-3474-002

8-98

Printed in U.S.A.



# **HIGH SPECIFICATION DATA TRANSCEIVER PART NO. 242-3474-XX0**

Copyright© 1998 by the Johnson Data Telemetry Corporation.

The Johnson Data Telemetry Corporation designs and manufactures radios and radio modems to serve a wide variety of data communication needs. The Johnson Data Telemetry Corporation produces equipment for the fixed data market including SCADA systems for utilities, petrochemical, waste and fresh water management markets and RF boards for OEM applications in the Radio Frequency Data Capture market.

## **DATA TELEMETRY PRODUCT WARRANTY**

The manufacturer's warranty statement for this product is available from your product supplier or from the Johnson Data Telemetry Corporation, 299 Johnson Avenue, Box 1733, Waseca, MN 56093-0833. Phone (507) 835-8819.

## **WARNING**

This device complies with Part 15 of the FCC rules. Operation is subject to the condition that this device does not cause harmful interference. In addition, changes or modification to this equipment not expressly approved by Johnson Data Telemetry Corporation could void the user's authority to operate this equipment (FCC rules, 47CFR Part 15.19).

DO NOT allow the antenna to come close to or touch, the eyes, face, or any exposed body parts while the radio is transmitting.

DO NOT operate the radio near electrical blasting caps or in an explosive atmosphere.

DO NOT operate the radio unless all the radio frequency connectors are secure and any open connectors are properly terminated.

DO NOT allow children to operate transmitter equipped radio equipment.

## **SAFETY INFORMATION**

Proper operation of this radio will result in user exposure below the Occupational Safety and Health Act and Federal Communication Commission limits.

The information in this document is subject to change without notice.



is a trademark of the Johnson Data Telemetry Corporation.



# TABLE OF CONTENTS

<b>1</b>	<b>GENERAL INFORMATION</b>	
1.1	SCOPE OF MANUAL	1-1
1.2	EQUIPMENT DESCRIPTION	1-1
	GENERAL	1-1
	DM3474 SYNTHESIZER PROGRAMMING	1-1
1.3	TRANSCEIVER IDENTIFICATION	1-1
1.4	PART NUMBER BREAKDOWN	1-2
1.5	ACCESSORIES	1-2
1.6	FACTORY CUSTOMER SERVICE	1-2
1.7	PRODUCT WARRANTY	1-3
1.8	REPLACEMENT PARTS	1-3
1.9	IF A PROBLEM ARISES	1-4
	FACTORY REPAIR	1-4
	GENERAL SPECIFICATIONS	1-5
<b>2</b>	<b>INSTALLATION</b>	
2.1	PRE-INSTALLATION CHECKS	2-1
2.2	INTERFACING WITH DATA EQUIPMENT	2-1
	DM3474 ONLY	2-1
<b>3</b>	<b>PROGRAMMING</b>	
3.1	INTRODUCTION	3-1
3.2	DM3474 SYNTHESIZER DATA PROTOCOL	3-1
	D-WORD	3-1
	B-WORD	3-2
	A-WORD	3-2
3.3	RECEIVE TO TRANSMIT SEQUENCE	3-6
3.4	TRANSMIT TO RECEIVE SEQUENCE	3-7
<b>4</b>	<b>CIRCUIT DESCRIPTION</b>	
4.1	GENERAL	4-1
	INTRODUCTION	4-1
	SYNTHESIZER	4-1
	RECEIVER	4-1
	TRANSMITTER	4-2
4.2	SYNTHESIZER	4-2
	INTRODUCTION	4-2
	VOLTAGE-CONTROLLED OSCILLATOR	4-5
	VCO AND REFERENCE OSCILLATOR MODULATION	4-6
	CASCODE AMPLIFIERS (Q851/Q852)	4-6
	AMPLIFIER (Q853)	4-6
	VOLTAGE FILTER (Q832)	4-6
	VCO FREQUENCY SHIFT (Q831)	4-6
	SYNTHESIZER INTEGRATED CIRCUIT (U801)	4-7
	LOCK DETECT	4-7

# TABLE OF CONTENTS

---

<b>4.3</b>	<b>RECEIVER CIRCUIT DESCRIPTION</b> . . . . .	4-8
	HELICAL FILTER (Z201), RF AMPLIFIER (Q201) . . . . .	4-8
	MIXER (U221), FIRST LO AMPLIFIER (Q301) . . . . .	4-8
	AMPLIFIER (Q222), CRYSTAL FILTER (Z221/Z222), IF AMP (Q221) . . . . .	4-8
	SECOND LO AMP/TRIPLER (Q401), SECOND IF FILTER (Q901) . . . . .	4-9
	SECOND MIXER/DETECTOR (U241) . . . . .	4-9
<b>4.4</b>	<b>TRANSMITTER CIRCUIT DESCRIPTION</b> . . . . .	4-10
	BUFFER (Q851) . . . . .	4-10
	PRE-DRIVER (Q501), DRIVER (Q521) . . . . .	4-11
	-5V POWER CONTROL SUPPLY . . . . .	4-11
	FINAL (Q541), POWER CONTROL (U542) . . . . .	4-11
	ANTENNA SWITCH (CR561, CR562) . . . . .	4-11
<b>5</b>	<b>SERVICING</b>	
<b>5.1</b>	<b>GENERAL</b> . . . . .	5-1
	PERIODIC CHECKS . . . . .	5-1
	SURFACE-MOUNTED COMPONENTS . . . . .	5-1
	SCHEMATIC DIAGRAMS AND COMPONENT LAYOUTS . . . . .	5-1
	REPLACEMENT PARTS LIST . . . . .	5-1
	TCXO MODULE NOT SERVICEABLE . . . . .	5-1
<b>5.2</b>	<b>SYNTHESIZER SERVICING</b> . . . . .	5-1
	INTRODUCTION . . . . .	5-1
	REFERENCE OSCILLATOR . . . . .	5-2
	VCO . . . . .	5-2
	SYNTHESIZER (U801) . . . . .	5-2
<b>5.3</b>	<b>RECEIVER SERVICING</b> . . . . .	5-3
	SUPPLY VOLTAGES AND CURRENT . . . . .	5-3
	MIXER/DETECTOR (U201) . . . . .	5-3
	RF AMPLIFIER (Q201) AND FIRST MIXER (Q221) . . . . .	5-4
	RF AND IF AMPLIFIERS, FIRST MIXER . . . . .	5-4
<b>5.4</b>	<b>TRANSMITTER SERVICING</b> . . . . .	5-4
	SUPPLY VOLTAGES AND CURRENT . . . . .	5-4
<b>6</b>	<b>ALIGNMENT PROCEDURE AND PERFORMANCE TESTS</b>	
<b>6.1</b>	<b>GENERAL</b> . . . . .	6-1
<b>6.2</b>	<b>DL3474 TRANSCEIVER ONLY</b> . . . . .	6-1
	FREQUENCY AND CONTROL LINE VOLTAGE CHECK . . . . .	6-1
	2W TRANSMITTER POWER ALIGNMENT . . . . .	6-1
	LOW POWER ALIGNMENT . . . . .	6-2
	MODULATION FLATNESS ALIGNMENT . . . . .	6-3
	RECEIVER ALIGNMENT . . . . .	6-4
	IF AND AUDIO ADJUSTMENTS . . . . .	6-4
<b>7</b>	<b>PARTS LIST</b>	

# TABLE OF CONTENTS

---

## 8 SCHEMATICS AND COMPONENT LAYOUTS

VCO COMPONENT LAYOUT .....	8-2
TRANSCEIVER COMPONENT LAYOUT-COMPONENT SIDE VIEW .....	8-3
TRANSCEIVER COMPONENT LAYOUT-OPPOSITE SIDE VIEW .....	8-4
TRANSCEIVER SCHEMATIC .....	8-5

## LIST OF FIGURES

3-1 D-WORD .....	3-3
3-2 B-WORD .....	3-4
3-3 A-WORD .....	3-4
3-4 SERIAL INPUT WORD FORMAT .....	3-5
3-5 RX TO TX TIMING DIAGRAM .....	3-6
3-6 TX TO RX TIMING DIAGRAM .....	3-7
4-1 DATA TRANSCEIVER BLOCK DIAGRAM .....	4-3
4-2 U801 SYNTHESIZER BLOCK DIAGRAM .....	4-4
4-3 U241 BLOCK DIAGRAM .....	4-9
5-1 RECEIVER SERVICING FLOWCHART .....	5-4
5-2 TRANSMITTER SERVICING FLOWCHART .....	5-5
6-1 TRANSMITTER TEST SETUP .....	6-2
6-2 RECEIVER TEST SETUP .....	6-4
6-3 ALIGNMENT POINTS DIAGRAM .....	6-6
8-1 VCO COMPONENT LAYOUT (COMPONENT SIDE VIEW) .....	8-2
8-2 TRANSCEIVER COMPONENT LAYOUT (COMPONENT SIDE VIEW) .....	8-3
8-3 TRANSCEIVER COMPONENT LAYOUT (OPPOSITE COMPONENT SIDE VIEW) .....	8-4
8-4 TRANSCEIVER SCHEMATIC .....	8-5

## LIST OF TABLES

1-1 ACCESSORIES .....	1-2
-----------------------	-----

# TABLE OF CONTENTS

This page intentionally left blank.



---

## GENERAL INFORMATION

---

### 1.1 SCOPE OF MANUAL

---

This service manual contains alignment and service information for the Johnson Data Telemetry (JDT) DM3474 UHF High Specification Data Module Transceiver.

### 1.2 EQUIPMENT DESCRIPTION

---

#### 1.2.1 GENERAL

The JDT DM3474 is a synthesized data transceiver (transmitter and receiver) which operates in the 403-512 MHz UHF frequency range. Transmitter power output is 2 watts nominal, and operation is simplex or half duplex.

Versions of the 3474 covered in this manual are indicated in Section 1.4. The 3474 has a frequency stability of  $\pm 1.5$  PPM (see Section ).

The number of channels that can be selected with the DM3474 model is determined by the customer supplied synthesizer loading circuitry.

#### 1.2.2 DM3474 SYNTHESIZER PROGRAMMING

The DM3474 requires customer supplied circuitry to load the synthesizer with channel information. The protocol that this circuitry must follow is described in Section .

### 1.3 TRANSCEIVER IDENTIFICATION

---

The transceiver identification number is printed on a label that is affixed to the PC board. The following information is contained in that number:

Model	Revision Letter	Manufacture Date	Plant	Warranty Number
3474	2 A	1 4 3	A	12345

Range Eighth Digit of PN      Week No. of Year      Year

# GENERAL INFORMATION

---

## 1.4 PART NUMBER BREAKDOWN

---

The following is a breakdown of the part number used to identify this transceiver:

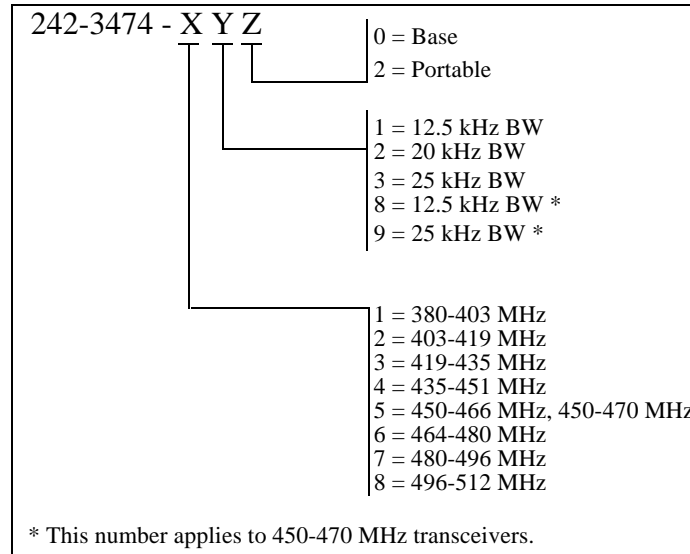

## 1.5 ACCESSORIES

---

Accessories available for the 3474 data transceiver are listed in Table 1-1.

**Table 1-1 ACCESSORIES**

Accessory	Part No.
MCX to SMA RF cable	023-3472-009

## 1.6 FACTORY CUSTOMER SERVICE

---

The Customer Service Department at JDT provides customer assistance on technical problems and the availability of local and factory repair facilities. Customer Service hours are 7:30 a.m. - 4:30 p.m. Central Time, Monday - Friday. From within the continental United States, the Customer Service Department can be reached at this toll-free number

**1-800-992-7774**

# GENERAL INFORMATION

---

When your call is answered at JDT, you will hear a brief message that contains the options: “1” for Sales, “2” for Order Entry, “3” for Customer Service, “4” for Marketing, “7” for other issues, or “9” to repeat the message.

When you enter a first number of “3”, you may enter “1” for Technical Assistance, “2” for Product Repair or “3” for Warranty. This number may be entered during or after the message using a tone-type telephone. If you have a pulse-type telephone wait until the message is finished and an operator will come on the line to assist you. You can enter the four digit extension number of the person that you want to reach at any time. If you are calling from outside the continental United States, the Customer Service numbers are:

Customer Service Department - (507) 835-6911

FAX Machine - Cust Serv(507) 835-6969

You can contact the Customer Service Department by mail or email. Please include any information that may help solve your problem. The mailing or email addresses are:

Johnson Data Telemetry Corporation

Customer Service Department

299 Johnson Avenue

P.O. Box 1733

Waseca, MN 56093-0514

support@johnsondata.com

## 1.7 PRODUCT WARRANTY

---

The warranty statement for this transceiver is available from the Warranty Department at JDT (see address or telephone number in Section 1.6). The Warranty Department may also be contacted for Warranty Service Reports, claim forms, or any questions concerning warranties or warranty service.

## 1.8 REPLACEMENT PARTS

---

Replacement parts can be ordered directly from the Service Parts Department. To order parts by phone, dial the toll-free number and then enter “3” as described in Section 1.6. When ordering, please supply the part number and quantity of each part ordered. JDT customers should give their account number. If there is uncertainty about the part number, include the model number of the equipment the part is from (refer to Section 1.3).

You can send your order by mail or FAX (see Section 1.6 for mailing address). Mail orders should be sent to the Service Parts Department.

FAX Machine - Sales (507) 835-6648

# GENERAL INFORMATION

---

## 1.9 IF A PROBLEM ARISES...

---

JDT products are designed for long life and failure-free operation. If a problem arises, factory service is available. Contact the Customer Service Department before returning equipment. A service representative may suggest a solution eliminating the need to return equipment.

### 1.9.1 FACTORY REPAIR

Component level repair is not recommended on the DM3474 Transceiver. Surface mount technology is used to install many components that require specialized training and equipment to service board level components. JDT's factory is best equipped to diagnose problems and make component level repairs.

When returning equipment for repair, fill out a Factory Request Form for each unit to be repaired regardless of warranty status. These forms are available free of charge by calling Customer Service (see Section 1.6). Describe the problem in the space provided and note any prior physical damage to the equipment. Include a form in the shipping container with each unit. Your phone number and contact name are **important**. There are times when technicians have specific questions that need to be answered in order to identify the problem and repair the equipment.

When returning equipment for repair, use a reference number on your paperwork in case you need to call Customer Service about your unit. That number is referenced on the repair order to make it easier to locate your unit in the lab.

Return authorization (RA) numbers are not necessary unless you have been given one by the Customer Service Department. They require RA numbers for exchange units or if they want to be aware of a specific problem. If you have been given an RA number, reference this number on the Factory Repair Request Form sent with the unit. The repair lab will contact the Customer Service Department when the unit arrives.

# GENERAL INFORMATION

---

The following are general specifications intended for use in testing and servicing this transceiver. For current advertised specifications, refer to the specification sheet available from the Marketing Department. Specifications are subject to change without notice.

## GENERAL

Frequency Range	403-512 MHz
Frequency Control	Synthesized
Channel Spacing	12.5/20/25 kHz
Mode of Operation	Simplex or Half Duplex
Operating Voltage	+7.5V DC $\pm$ 10%
Regulated Supply Voltages	+5V DC $\pm$ 5%
RF Input/Output	MCX Jack
Power and Data Interface	14-pin in-line socket, 100 mil center
Operating Temperature	-30° to +60° C (-22° to +140° F)
Maximum Dimensions	2.83" L (7.19 cm), 2.19" W (5.56 cm), 0.64" H (1.70 cm)
Weight (w/o Loader Bd)	2.3 oz (65 g)
FCC Compliance	DM3474 customer must apply

## RECEIVER

Bandwidth	16 MHz
Frequency Stability	$\pm$ 1.5 PPM
Sensitivity - 12 dB SINAD	0.45 $\mu$ V
RF Input Impedance	50 ohms
Spurious and Image Rejection	-70 dB
Selectivity	-60 dB (12.5 kHz), -70 dB (20/25 kHz)
Intermodulation	-70 dB
FM Hum and Noise	-40 dB (12.5 kHz), -45 dB (20/25 kHz)
Conducted Spurious	-57 dBm
Receive Current Drain	< 70 mA nominal
Receive Attack Time	< 7 ms (dependent on synthesizer loading implementation)
Audio	
Distortion	< 3%
Output Level DM3474	600-1200 mV P-P or 200-400 mV RMS (1 kHz at $\pm$ 3 kHz)
Response	
DM3474	$\pm$ 2 dB from DC to 5 kHz (reference to 1 kHz)
Minimum Load Impedance	1k ohms

## TRANSMITTER

Bandwidth	16 MHz
Frequency Stability	$\pm$ 1.5 PPM
TCXO Coupling	DC
RF Power Output	2W nominal adjustable to 500 mW (-XX0) 500 mW nominal
RF Output Impedance	50 ohms
Modulation Distortion	< 3%

# GENERAL INFORMATION

---

Duty Cycle	50%, 60 seconds maximum transmit
Transmitter Attack Time	< 7 ms (dependent on synthesizer implementation)
Spurious and Harmonic FM	-37 dBm
FM Hum and Noise	-40 dB 12.5 kHz, -45 dB 25 kHz
Audio Response	±1.5 dB from DC to 5 kHz (reference to 1 kHz) Programmable to ±1 dB at the RF band edges via J201, pin 14.
Data Input Impedance	100k ohm
Modulation Response	±1 dB from DC to 5 kHz (reference to 1 kHz)
Current Drain	< 800 mA at 2W, +7.5V DC

### 2.1 PRE-INSTALLATION CHECKS

---

Field alignment should not be required before the 3474 is installed. However, it is a good practice to check the performance to ensure that no damage occurred during shipment. Performance tests are located in Section 6.2.

### 2.2 INTERFACING WITH DATA EQUIPMENT

---

#### 2.2.1 DM3474 ONLY

Connector J201 on the data transceiver PC board provides the interface with the data equipment. This is a 14-pin female connector with .025" square pins on 0.1" centers (Dupont 76308-114).

The following is a general description of the various J201 input and output signals.

**Pin 1 (Ground)** - Chassis ground.

**Pin 2 (+7.5V DC Continuous)** - This voltage should be stabilized near +7.5V DC. Variations from +6V to +9V can change power output as much as 6 dB.

**Pin 3 (+7.5V DC Transmit)** - This input should be +7.5V DC in transmit mode only.

**Pin 4 (+5V DC Receive Control Line)** - This input should be +5V DC in the receive mode only,  $\leq 0.3$  V DC in Tx, input impedance  $\geq 10k$  ohms.

**Pin 5 (+5V DC Continuous)** - This voltage should be stabilized near +5V DC.

**Pin 6 (Tx Input)** - Provides a response of  $\pm 1.5$  dB from DC to 5 kHz. The sensitivity is approximately 7 kHz deviation per volt RMS. When this input is used, a temperature compensated 2.5V DC bias is required because variations in voltage cause the frequency to change. In addition, the transceiver regulatory compliance must be applied for with the customer supplied modulation limiting/filter circuit and chassis.

**Pin 7 (Synthesizer Lock)** - Output from synthesizer lock detect circuit. Low = unlocked, high = locked.

**Pin 8 (Synthesizer Enable)** - Latch enable signal. A rising edge on this input latches the data loaded into synthesizer IC U801.

**Pin 9 (Synthesizer Data)** - Serial data line used for programming synthesizer IC U801.

**Pin 10 (Synthesizer Clock)** - Software generated serial clock. Data is valid on the rising edge of this signal.

# INSTALLATION

---

**Pin 11 (Carrier Detect)** - This output is not used at this time.

**Pin 12 (RSSI Output)** - The RSSI (Receive Signal Strength Indicator) output provides a voltage that increases in proportion to the strength of the RF input signal.

**Pin 13 (Rx Output)** - The data output level is 600-1200 millivolts P-P (200-400 mV RMS) with a modulation signal of 1 kHz at 60% of maximum deviation. The output is DC coupled and referenced to +2.5V DC. Load impedance should be 10k-100k ohms.



### 3.1 INTRODUCTION

---

The information in Section 3.2 describes synthesizer programming protocol. This information can be used as a basis for designing the synthesizer programming hardware and software required.

### 3.2 DM3474 SYNTHESIZER DATA PROTOCOL

---

Programming of the dividers and the charge pumps are performed on a 3-line bus; SYNTH ENABLE, SYNTH DATA, AND SYNTH CLK. On initial power up three 34-bit words are required to load the 3474 Data Transceiver. After the initial load, one 32-bit word can be used to change channels.

The SA7025 Synthesizer IC uses four address words; D, C, B and A (see Figure 3-4). The C word is not used in the 3474. The 24- and 32-bit words contain one or four address bits, depending on the address bits, the data is latched into registers. When the A-word is loaded, the data of these temporary registers is loaded together with the A-word into the work registers.

#### 3.2.1 D-WORD

Refer to Figure 3-1.

TCXO Reference Frequency is 17.5 MHz.

Loop Reference Frequency is 50 kHz.

Reference Divide (NR) = 17.5 MHz ÷ 50 kHz = 350 Decimal or 000101011110 Binary.

The 3474 has frequency resolution of 6.25 kHz and 10 kHz. When programming 6.25 kHz frequency resolution use FMOD=8. When programming 10 kHz frequency resolution use FMOD=5.

Example:

$$(FCM) \div FMOD = 50 \text{ kHz} \div 8 = 6.25 \text{ kHz}$$

$$(FCM) \div FMOD = 50 \text{ kHz} \div 5 = 10 \text{ kHz}$$

Where:

FCM = Loop Reference Frequency

FMOD = Fractional N Modulus

Since FMC is the same for both 6.25 kHz and 10 kHz the loop dynamics are very similar and the same loop filter values can be used.

# PROGRAMMING

---

## 3.2.2 B-WORD

The B-Word is 24-bits long (see Figure 3-2). It contains the Address, Charge Pump setting factor (CN), Binary Acceleration factors (CK, CL), and Prescaler Type (PR).

The Charge Pump Current setting (CN) could be changed on a channel-by-channel basis for ultimate rejection of the Fraction N spurious responses close into the carrier frequency. The 3474 synthesizer has an adjust (R855) for the fractional compensation current. The factory preset value will allow CN to be set to the following ranges:

Frequency in a Band	CN
Lowest TX	86
Highest TX	90
Lowest RX	96
Highest RX	100

The value of CN should be interpolated for frequencies between the band edges. With these recommended values of CN, the transceiver should have the fractional spurs minimized far below the levels needed to make ETSI 70 dB adjacent channel RX or TX specifications.

Example:

Model 3474-530 is a 450-466 MHz transceiver.  
458 MHz TX CN = 88      01011000 Binary  
458 MHz RX CN = 98      01100010 Binary

## 3.2.3 A-WORD

The A-Word must be sent last (see Figure 3-3). The A-Word contains new data for the loop dividers and is programmed for every channel. The A-Word can be a 24-bit or 32-bit word depending on the state of the flag LONG in the D-Word. The 24-bit word (A0) is sent if LONG=0 and the 32-bit word (A1) is sent if LONG=1. The extra 8-bits in A1 are the CN charge pump settings. Upon power up the D-, B- and A-Words must be sent, but after that only the A1 word needs to be sent.

The Fractional-N increment (NF) is a 3-bit word that is channel dependent. NF is used to program the sub-channels below the 50 kHz Loop Reference frequency.  $FCM = 50 \text{ kHz}$  and if  $FMOD = 8$ , then the Fractional-N increment is:  $50 \text{ kHz} \div 8 = 6.25 \text{ kHz}$

To program an 18.75 kHz channel:

$$NF = 18.75 \text{ kHz} \div 6.25 \text{ kHz}$$
$$NF = 3$$

NM1 and NM2 are calculated as follows:

$$N = (NM1 + 2) \times 64 + NM2 \times 65 \quad \text{Where: } N = \text{total division ratio}$$

NM1 = Number of main divider cycles when prescaler modulus equals 64

NM2 = Number of main divider cycles when prescaler modulus equals 65

Example:

Calculate NM1 and NM2 to Receive 454.500 MHz.

$$LO = 454.5 + 52.95 = 507.45 \text{ MHz}$$

(52.95 MHz IF with High Side Injection)

$$N = RX LO \div FCM = 507.45 \div 0.05 = 10149$$

(FCM = Loop Reference Frequency)

$$\begin{aligned} NM2 &= 64 \times \text{FRAC} [N \div 64] \\ &= 64 \times \text{FRAC} [10149 \div 64] \\ &= 64 \times 0.57813 \\ &= 37 \end{aligned}$$

$$\begin{aligned} NM1 &= \text{INTEGER} [N \div 64] - 2 - NM2 \\ &= 158 - 2 - 37 \\ &= 119 \end{aligned}$$

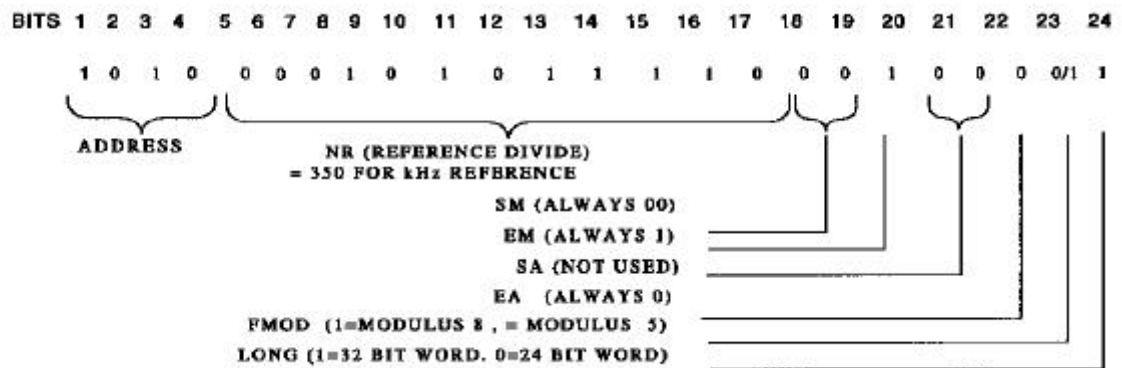
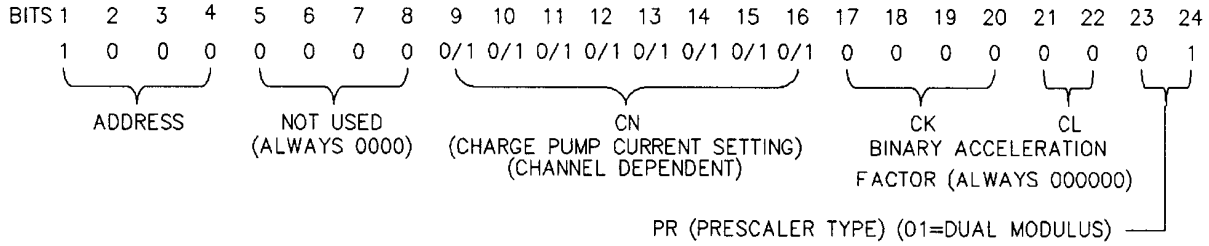
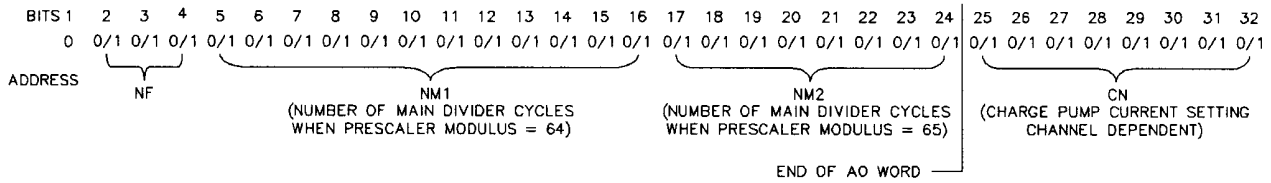

Figure 3-1 D-WORD

# PROGRAMMING



**Figure 3-2 B-WORD**



**Figure 3-3 A-WORD**

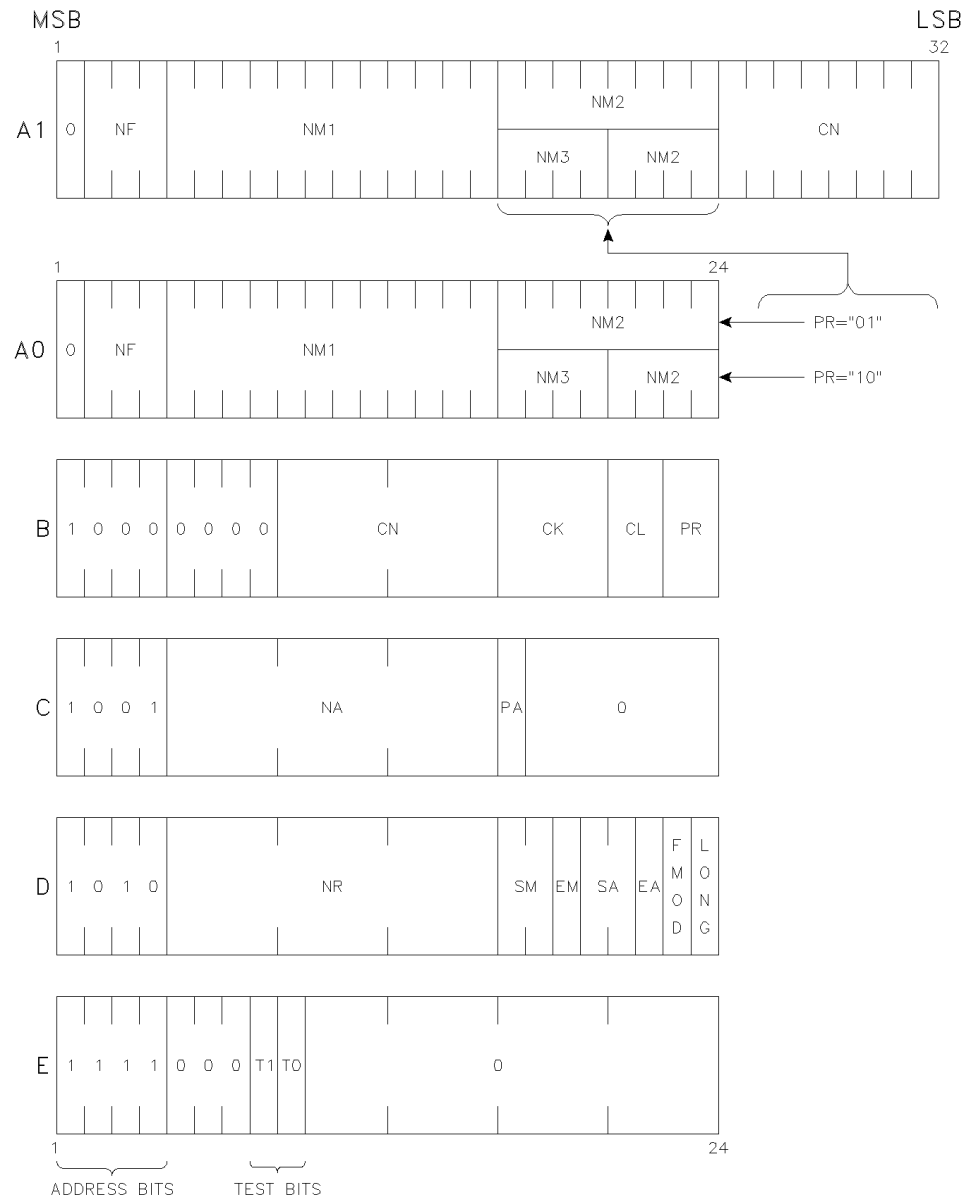

**Figure 3-4 SERIAL INPUT WORD FORMAT**

# PROGRAMMING

## 3.3 RECEIVE TO TRANSMIT SEQUENCE

Refer to Figure 3-5.

1. Synthesizer is loaded (B and A 24-Bit words or one long 32-bit A-Word).
2. The state of the 5RCL line does not have to be changed until the last bit is sent. However, RX will cease as soon as it is changed.
3. The SYNTH ENABLE line should be held HIGH for 2 to 3 milliseconds after the last word is sent. This puts the frequency synthesizer in a SPEEDUP MODE and slightly improves lock times.
4. After the last word is strobed in, 7 milliseconds (worst case) should elapse before 7.5 TX is turned ON. This allows the synthesizer to come within 1 kHz of the desired frequency.

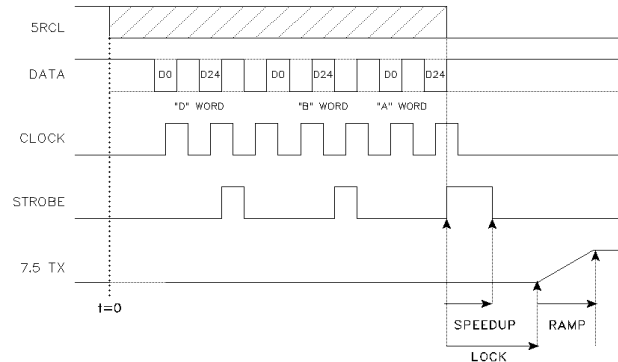

**Figure 3-5 RX TO TX TIMING DIAGRAM**

Dekey is a length of time to allow the TX to power down while the synthesizer is still in lock. This is needed to meet ETSI (European Telecommunications Standards Institute) adjacent power specifications. Dekey is approximately 3 ms in length. The 7.5 TX should be ramped or optimally filtered in such a way as to reduce the  $S_{inx/x}$  power spreading. Speedup will slightly improve lock times and is 1 to 2 ms.

## 3.4 TRANSMIT TO RECEIVE SEQUENCE

Refer to Figure 3-6.

1. 7.5 TX is turned OFF. For best TX adjacent channel power performance this could be shaped.
2. The synthesizer load process could begin slightly before, but when the last bit is strobed in the synthesizer it will become unlocked. For ETSI specs, the TX should be turned OFF “on-frequency”.
3. The 5RCL line should switch from low to high AFTER the 7.5 TX is switched. The 5RCL not only turns the RX circuits on but also Pin Shifts the VCO.
4. For quickest lock times the SYNTH ENABLE line on the last load word should be held high for 2 to 3 milliseconds. It MUST NOT be left high as the synthesizer in the SPEEDUP mode has poor noise performance and would degrade the RX performance.

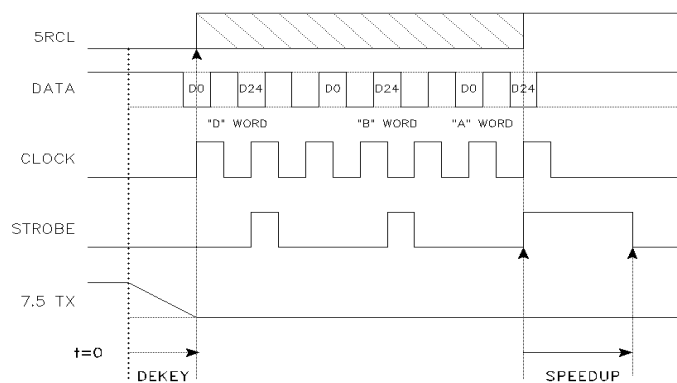

**Figure 3-6 TX TO RX TIMING DIAGRAM**

Speedup is 2 to 3 ms

Lock is approximately 7 ms

Ramp is approximately 3 ms

### IMPORTANT

*If the receiver is to be operated at 510-512 MHz (-810), a spurious condition may occur to degrade the receiver sensitivity 2 to 3 dB. If this degradation is unacceptable, the synthesizer can be reprogrammed to a comparison frequency (FCM) of 31.25 kHz (so that a multiple of this would not be 52.95 MHz) and a modulus (FMOD) of 5 with a reference divide (NR) of 560. These parameters place the spurious at harmonics of 31.25 kHz (instead of 50 kHz) outside the passband of the IF filters where the sensitivity is not degraded.*

# PROGRAMMING

---

This page intentionally left blank.



## CIRCUIT DESCRIPTION

---

### 4.1 GENERAL

---

#### 4.1.1 INTRODUCTION

The main subassemblies of this transceiver are the RF board, VCO board, and TCXO. A block diagram of the transceiver is located in Figure 4-1.

The VCO board is enclosed by a metal shield and soldered directly to the RF board. The VCO is not serviceable.

The 3474 is available with a reference oscillator stability of  $\pm 1.5$  PPM. The TCXO (Temperature Compensated Crystal Oscillator) is soldered directly to the RF board.

#### 4.1.2 SYNTHESIZER

The VCO (voltage-controlled oscillator) output signal is the receiver first injection frequency in the Receive mode and the transmit frequency in the Transmit mode. The first injection frequency is 52.95 MHz above the receive frequency. The frequency of this oscillator is controlled by a DC voltage produced by the phase detector in synthesizer chip U801.

Channels are selected by programming counters in U801 to divide by a certain number. This programming is performed over a serial bus formed by the Synth Clock, Synth Enable, and Synth Data pins of J201. This programming is performed by user supplied hardware and software (see Section ).

The frequency stability of the synthesizer in both the receive and transmit modes is established by the stability of the reference oscillator described in the preceding section. These oscillators are stable over a temperature range of  $-30^{\circ}$  to  $+60^{\circ}$  C ( $-22^{\circ}$  to  $+140^{\circ}$  F).

#### 4.1.3 RECEIVER

The receiver is a double-conversion type with intermediate frequencies of 52.95 MHz / 450 kHz. Two helical bandpass filters reject the image, half IF, injection, and other unwanted frequencies. A four-pole crystal filter enhances receiver selectivity

# CIRCUIT DESCRIPTION

---

## 4.1.4 TRANSMITTER

The transmitter produces a nominal RF power output of 2W adjustable to 500 mW (-XX0). Frequency modulation of the transmit signal occurs in the synthesizer. Transmit audio processing circuitry is contained in the customer-supplied equipment.

## 4.2 SYNTHESIZER

---

### 4.2.1 INTRODUCTION

A block diagram of the synthesizer is shown in Figure 4-1 and a block diagram of Synthesizer IC U801 is shown in Figure 4-2. As stated previously, the synthesizer output signal is produced by a VCO (voltage controlled oscillator). The VCO frequency is controlled by a DC voltage produced by the phase detector in U801. The phase detector senses the phase and frequency of the two input signals and causes the VCO control voltage to increase or decrease if they are not the same. The VCO is then “locked” on frequency.

Programming of the synthesizer provides the data necessary for the internal prescaler and counters. One input signal is the reference frequency. This frequency is produced by the 17.5 MHz reference oscillator (TCXO). The other input signal is the VCO frequency.

# CIRCUIT DESCRIPTION

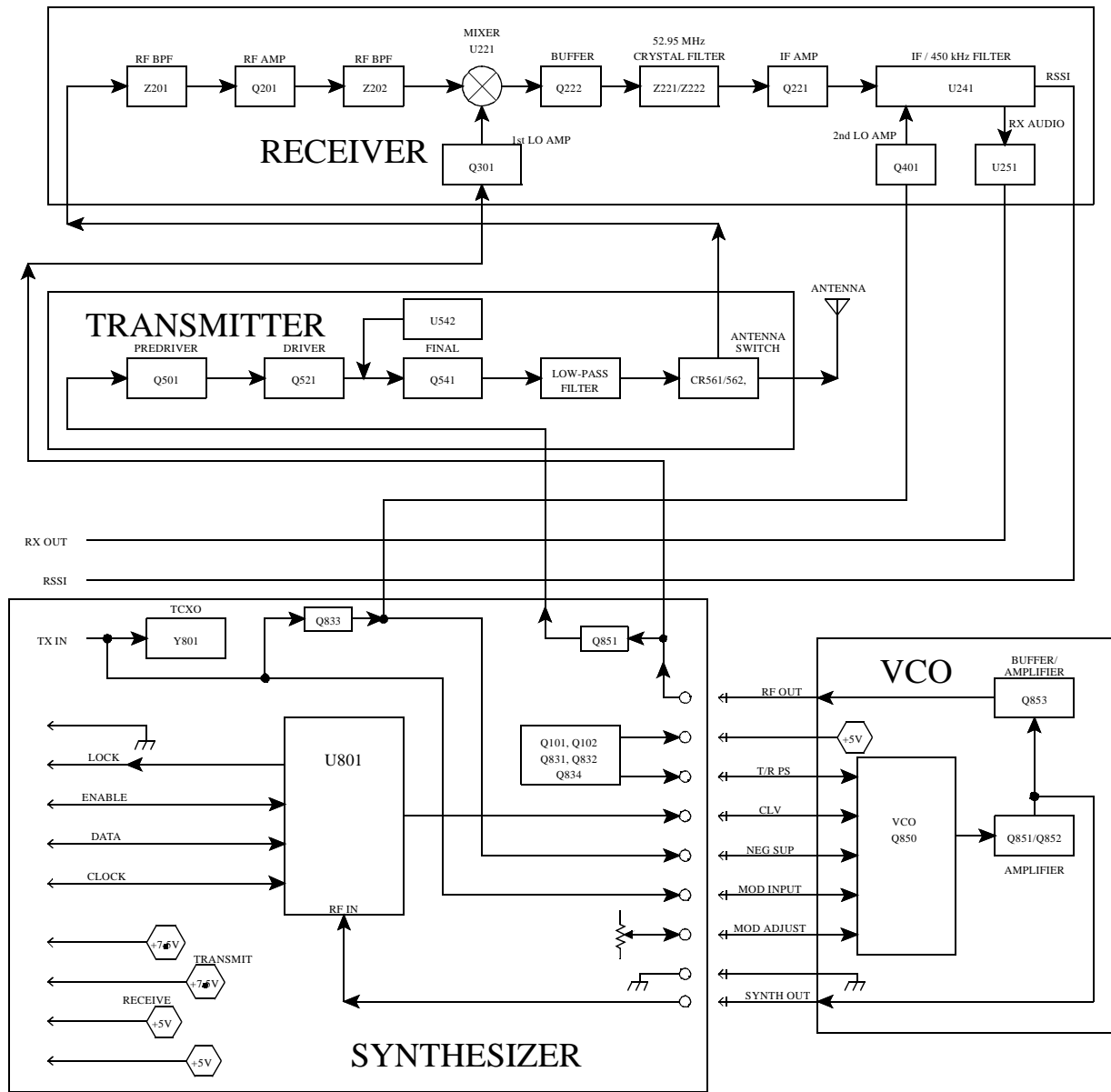

Figure 4-1 DATA TRANSCEIVER BLOCK DIAGRAM

# CIRCUIT DESCRIPTION

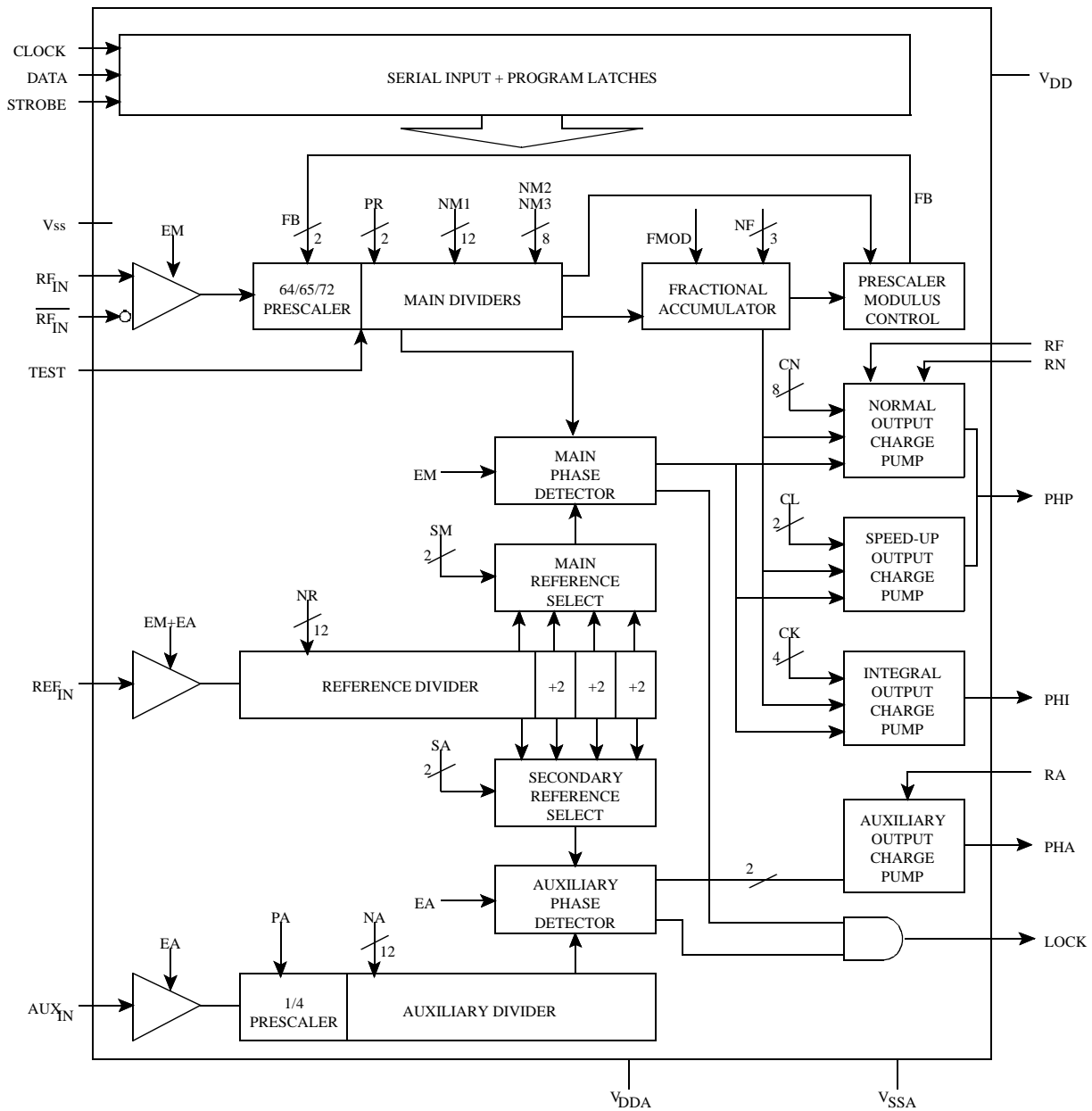

Figure 4-2 U801 SYNTHESIZER BLOCK DIAGRAM

## 4.2.2 VOLTAGE-CONTROLLED OSCILLATOR

### Oscillator (Q850)

The VCO is formed by Q850, several capacitors and varactor diodes, and a ceramic resonator. It oscillates at the transmit frequency in transmit mode and first injection frequency in the receive mode (approximately 450 MHz in transmit and 500 MHz in receive).

Biasing of Q850 is provided by R862, R867 and R868. An AC voltage divider formed by C859, C861 and C862 initiates and maintains oscillation and also matches Q850 to the tank circuit. The ceramic resonator is grounded at one end to provide shunt inductance to the tank circuit.

### Frequency Control and Modulation

The VCO frequency is controlled in part by DC voltage across varactor diodes CR854, CR855, CR856 and CR851. As voltage across a reverse-biased varactor diode increases, its capacitance decreases. Therefore, VCO frequency increases as the control voltage increases. CR854/CR855 and CR856/CR851 are paralleled varactor to divide the capacitance and improve linearity. The varactors are biased at -2V to adjust to the voltage output of U801. The control line is isolated from tank circuit RF by choke L851 and L854 and decoupling capacitor C854. The amount of frequency change produced by CR854/CR855/CR856/CR851 is controlled by series capacitor C853.

The -2V applied to the VCO is derived from the TCXO frequency that is amplified by Q833, rectified by CR831 and filtered by C844, C845, C846 and C847 on the RF board.

The VCO frequency is modulated using a similar method. The transmit audio/data signal is applied across varactor diode CR852 which varies the VCO frequency at an audio rate. Series capacitors C856/C870 set the amount of deviation produced along with CR853 and C858. R854 provides a DC ground on the anodes of CR852/CR853, and isolation is provided by R852 and C855.

The DC voltage across CR853 provides compensation to keep modulation relatively flat over the entire bandwidth of the VCO. This compensation is required because modulation tends to increase as the VCO frequency gets higher (capacitance of CR854/CR855/CR856/CR851 gets lower). CR853 also balances the modulation signals applied to the VCO and TCXO. An external voltage from J201, pin 14 can also adjust the modulation.

The DC voltage applied across CR853 comes from the modulation adjust control R810. R811 applies a DC biasing voltage to CR852; C814 provides DC blocking; and C818 attenuates AC signals applied through R811. RF isolation is provided by C858, R853, C817 and R812.

# CIRCUIT DESCRIPTION

---

## 4.2.3 VCO AND REFERENCE OSCILLATOR MODULATION

Both the VCO and reference oscillator (TCXO) are modulated in order to achieve the required frequency response. If only the VCO was modulated, the phase detector in U801 would sense the frequency change and increase or decrease the VCO control voltage to counteract the change (especially at the lower audio frequencies). If only the reference oscillator frequency is modulated, the VCO frequency would not change fast enough (especially at the higher audio frequencies). Modulating both VCO and reference oscillators produces a flat audio response. Potentiometer R810 sets the VCO modulation sensitivity so that it is equal to the reference oscillator modulation sensitivity.

## 4.2.4 CASCODE AMPLIFIERS (Q851/Q852)

The output signal on the collector of Q850 is coupled by L861/C864 to buffer amplifier Q851/Q852. This is a shared-bias amplifier which provides amplification and also isolation between the VCO and the stages which follow. The signal is direct coupled from the collector of Q852 to the emitter of Q851. The resistors in this circuit provide biasing and stabilization, and C865 and C866 are bypass capacitors.

## 4.2.5 AMPLIFIER (Q853)

Amplifier Q853 provides amplification and isolation between the VCO and receiver and transmitter. C868 provides matching between the amplifiers. Bias for Q853 is provided by R871, R872 and R874. Inductor L856 and capacitor C873 provide impedance matching on the output.

## 4.2.6 VOLTAGE FILTER (Q832)

Q832 is a capacitance multiplier to provide filtering of the 4.6V supply to the VCO. R836 provides transistor bias and C834 provides the capacitance that is multiplied. If a noise pulse or other voltage change appears on the collector, the base voltage does not change significantly because of C834. Therefore, base current does not change and transistor current remains constant. CR832 decreases the charge time of C834 when power is turned on. This shortens the start-up time of the VCO. C841, C840 and C855 are RF decoupling capacitors.

## 4.2.7 VCO FREQUENCY SHIFT (Q831)

The VCO must be capable of producing frequencies from approximately 403-564.95 MHz to produce the required receive injection and transmit frequencies. If this large of a shift was achieved by varying the VCO control voltage, the VCO gain would be undesirably high. Therefore, capacitance is switched in and out of the tank circuit to provide a coarse shift in frequency.

This switching is controlled by the T/R pin shift on J201, pin 4, Q831/Q834 and pin diode CR850. When a pin diode is forward biased, it presents a very low impedance to RF; and when it is reverse biased, it presents a very high impedance. The capacitive leg is switched in when in transmit and out when in receive.

When J201, pin 4 is high in receive, Q834 is turned off, Q101 is turned on and the collector voltage goes low. A low on the base of Q102 turns the transistor on and the regulated +5.5V on the emitter is on the collector for the receive circuitry. With a low on the base of Q831 the transistor is off and the collector is high. With a high on the collector of Q831 and a low on the emitter of Q834, this reverse biases CR850 for a high impedance.

The capacitive leg is formed by C851, CR850, C852 and C876. When J201, pin 4 is low in transmit, Q834 is turned on and a high is on the emitter, Q101 is turned off and the collector voltage goes high. A high on the base of Q102 turns the transistor off and the regulated +5.5V is removed from the receive circuitry. With a high on the base of Q831 the transistor is on and the collector is low. With a low on the collector of Q831 and a high on the emitter of Q834, this forward biases CR850 and provides an RF ground through C851 and C852/C876 are effectively connected to the tank circuit. This decreases the resonant frequency of the tank circuit.

## 4.2.8 SYNTHESIZER INTEGRATED CIRCUIT (U801)

### Introduction

Synthesizer chip U801 is shown in Figure 4-2. This device contains the following circuits: R (reference), Fractional-N, NM1 and NM2; phase and lock detectors, prescaler and counter programming circuitry. The basic operation was described in Section 4.2.1.

### Channel Programming

Frequencies are selected by programming the R, Fractional-N, NM1 and NM2 in U801 to divide by a certain number. These counters are programmed by a user supplied programming circuit. More information on programming is located in Section .

As previously stated, the counter divide numbers are chosen so that when the VCO is oscillating on the correct frequency, the VCO-derived input to the phase detector is the same frequency as the reference oscillator-derived frequency.

The VCO frequency is divided by the internal prescaler and the main divider to produce the input to the phase detector.

## 4.2.9 LOCK DETECT

When the synthesizer is locked on frequency, the SYNTH LOCK output of U801, pin 18 (J201, pin 7) is a high voltage. Then when the synthesizer is unlocked, the output is a low voltage. Lock is defined as a phase difference of less than 1 cycle of the TCXO.

# CIRCUIT DESCRIPTION

---

## 4.3 RECEIVER CIRCUIT DESCRIPTION

---

### 4.3.1 HELICAL FILTER (Z201), RF AMPLIFIER (Q201)

Capacitor C201 couples the receive signal from the antenna switch to helical filter Z201. (The antenna switch is described in Section 4.4.5.) Z201 is a bandpass filter tuned to pass only a narrow band of frequencies to the receiver. This attenuates the image and other unwanted frequencies. The helicals are factory set and should not be tuned.

Impedance matching between the helical filter and RF amplifier Q201 is provided by C203, C204 and L201. Q201 amplifies the receive signal to recover filter losses and also to increase receiver sensitivity. Biasing for Q201 is provided by R201, R202 and R203; and C208/C209 provide RF bypass. CR201 protects the base-emitter junction of Q201 from excessive negative voltages that may occur during high signal conditions. Additional filtering of the receive signal is provided by Z202, L202, and C205 provide impedance matching between Q201 and Z202. Resistor R204 is used to lower the Q of L202 to make it less frequency selective.

### 4.3.2 MIXER (U221), FIRST LO AMPLIFIER (Q301)

First mixer U221 mixes the receive frequency with the first injection frequency to produce the 52.95 MHz first IF. Since high-side injection is used, the injection frequency is 52.95 MHz above the receive frequency. The RF signal is coupled to the mixer through C206.

The first injection frequency from the VCO is coupled to the first local oscillator amplifier Q301 through C301. L301 and C302 match Q301 to the VCO. Bias for Q301 is provided by R301, R302 and R303, and C303 decouples RF signals. Impedance matching to the mixer is provided by L302, R304 and C304.

### 4.3.3 AMPLIFIER (Q222), CRYSTAL FILTER (Z221/Z222), IF AMP (Q221)

The output of U221 is coupled to buffer Q222. C222, R229 and Q222 match the 50 ohm output of U221. Bias for Q222 is provided by R228 and R229. The output of Q222 is matched to crystal filter Z221 via L222, C223 and R230. This filter presents a low impedance to 52.95 MHz and attenuates the receive, injection, and other frequencies outside the 52.95 MHz passband.

Z221 and Z222 form a 2-section, 4-pole crystal filter with a center frequency of 52.95 MHz and a -3 dB passband of 8 kHz (12.5 kHz BW) or 15 kHz (20/25 kHz BW). This filter establishes the receiver selectivity by attenuating the adjacent channel and other signals close to the receive frequency. C232, C224, and L223 adjust the coupling of the filter. L224, C225 and C227 provide impedance matching between the filter and Q221.

IF amplifier Q221 amplifies the 52.95 MHz IF signal to recover filter losses and improves receiver sensitivity. Biasing for Q221 is provided by R222, R223, R225 and R226 and C228, C229 decouple RF signals. The output of Q221 is coupled to the detector by C230.



# CIRCUIT DESCRIPTION

## 4.3.4 SECOND LO AMP/TRIPLER (Q401), SECOND IF FILTER (Q901)

The input frequency to Q401 is 17.5 MHz from TCXO Y801 coupled through C402. Bias for Q401 is provided by R401, R402, R403 and R404. C403, C404 decouple RF from the amplifier. L401, L402, C405, C406 and C407 pass the third harmonic of the input (52.5 MHz) to U241, pin 1. The output of the amplifier is coupled to U241, pin 1 by C241, and C410 and L404 provided low frequency decoupling.

## 4.3.5 SECOND MIXER/DETECTOR (U241)

### Oscillator and Mixer

As shown in Figure 4-3, U241 contains the second oscillator, second mixer, limiter, detector, and squelch circuitry. The 52.95 MHz IF signal is mixed with a 52.5 MHz signal produced by second LO amplifier Q401 from TCXO Y801.

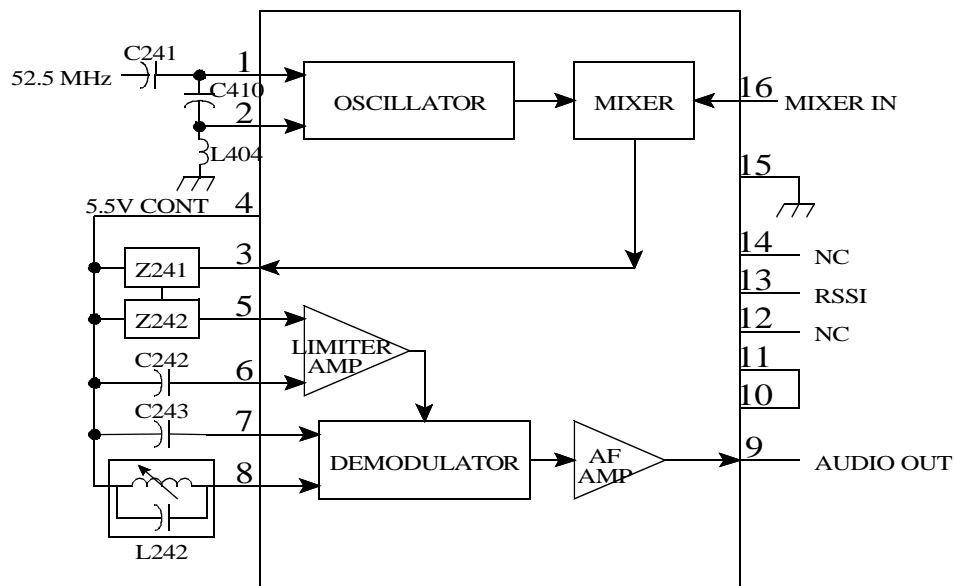

Figure 4-3 U241 BLOCK DIAGRAM

# CIRCUIT DESCRIPTION

---

## Second IF Filter

The output of the internal double-balanced mixer is the difference between 52.95 MHz and 52.5 MHz which is 450 kHz. This 450 kHz signal is fed out on pin 3 and applied to second IF filters Z241 and Z242. These filters have passbands of 9 kHz (12.5 kHz BW), 15 kHz (20 kHz BW) or 20 kHz (25 kHz BW) at the -6 dB points and are used to attenuate wideband noise.

## Limiter-Amplifier

The output of Z241/Z242 is applied to a limiter-amplifier circuit in U241. This circuit amplifies the 450 kHz signal and any noise present; then limits this signal to a specific value. When the 450 kHz signal level is high, noise pulses tend to get clipped off by the limiter; however, when the 450 kHz signal level is low, the noise passes through. C242, C243 decouple the 450 kHz signal.

## Quadrature Detector

From the limiter stage the signal is fed to the quadrature detector. An external phase-shift network connected to pin 8 shifts the phase of one of the detector inputs 90° at 450 kHz (all other inputs are unshifted in phase). When modulation occurs, the frequency of the IF signal changes at an audio rate as does the phase of the shifted input. The detector, which has no output with a 90° phase shift, converts this phase shift into an audio signal. L242 is tuned to provide maximum undistorted output from the detector. R242 is used to lower the Q of L242. From the detector the audio and data signal is fed out on pin 9.

## Audio/Data Amplifier

The audio/data output of U241 on pin 9 is fed to the audio amplifier U261. U261 amplifies the detected audio/data signal and shifts the DC bias level to 2.5V. The gain is set at approximately 1.5 by R261/R262. R263 and R264 provide a 1.9V DC reference bias voltage. The audio output of U261 is applied to J201, pin 13.

## Receive Signal Strength Indicator (RSSI)

U241, pin 13 is an output for the RSSI circuit which provides a current proportional to the strength of the 450 kHz IF signal. The voltage developed across R241 is applied to J201, pin 12.

## 4.4 TRANSMITTER CIRCUIT DESCRIPTION

---

### 4.4.1 BUFFER (Q851)

The output signal is applied to a 50-ohm pad formed by R851, R852, and R853. This pad provides attenuation and isolation. Q851 provides amplification and also additional isolation between the VCO and transmitter. Biasing for this stage is provided by R854, and decoupling of RF signals is provided by C852. Impedance matching with the transmitter is provided by L501 and C502.

## 4.4.2 PRE-DRIVER (Q501), DRIVER (Q521)

Pre-driver Q501 is biased class A by R501 and R502 and R506. L501 and C502 match Q501 to Q851. C520 and C508 bypass RF from the DC line, and R503 provides supply voltage isolation. R507 ties the +7.5V supply to the circuit for high power applications and R508 ties the circuit to +5V for low power applications. Impedance matching between Q501 and Q521 is provided by L502, L503 and C511. R504 and C504 provide negative feedback to prevent oscillation.

Driver Q521 is biased nearly Class C by R521 and R522. Impedance matching with Q541 is provided by L521, C525, C527, L522 and C526.

## 4.4.3 -5V POWER CONTROL SUPPLY

The 17.5 MHz from the TCXO is coupled through C902 to Q901. Bias for Q901 is provided by R903, R904, R901, R902 and R905. C901 and C903 provide RF decoupling. The amplified signal rectified by CR901/CR902 to produce a -5V DC source. C909 stabilizes the voltage level and C910 and C911 provide RF decoupling. This -5V source is used in the transmit power control circuit U542.

## 4.4.4 FINAL (Q541), POWER CONTROL (U542)

Q541 is biased for Class C operation. The output is matched to the low-pass filter by L541, C552, and several capacitors. The supply voltage is isolated from RF by ferrite bead EP541.

Power control is provided by U542. The 5.5V transmit supply is passed by U542 to power adjust R542. The other end of R542 is the rectified -5V from Q901. This negative voltage is required when low power is used to pinch off Q541 to the required output.

The low-pass filter consists of L561, C561, L562, C562, L563, C563 and L564. The filter attenuates spurious frequencies occurring above the transmit frequency band. The transmit signal is then fed through the antenna switch to antenna jack J501.

## 4.4.5 ANTENNA SWITCH (CR561, CR562)

The antenna switching circuit switches the antenna to the receiver in the receive mode and the transmitter in the transmit mode. In the transmit mode, +7.5V is applied to L565 and current flows through diode CR561, L566, diode CR562, and R562/R563. When a diode is forward biased, it presents a low impedance to the RF signal; conversely, when it is reverse biased (or not conducting), it presents a high impedance (small capacitance). Therefore, when CR561 is forward biased, the transmit signal has a low-impedance path to the antenna through coupling capacitor C568.

# CIRCUIT DESCRIPTION

---

C567, L566, and C570 form a discrete quarter-wave line. When CR561 is forward biased, this quarter-wave line is effectively AC grounded on one end by C570. When a quarter-wave line is grounded on one end, the other end presents a high impedance to the quarter-wave frequency. This blocks the transmit signal from the receiver. C569 matches the antenna to 50 ohms in transmit and receive.

In the receive mode, no power is applied to L565, so all the diodes are “off”. The receive signal then has a high-impedance path into the transmitter and a low-impedance path into the receiver because the quarter-wave line is not grounded.

### 5.1 GENERAL

---

#### 5.1.1 PERIODIC CHECKS

This transceiver should be put on a regular maintenance schedule and an accurate performance record maintained. Important checks are receiver sensitivity and transmitter frequency, modulation, and power output. A procedure for these and other tests is located in Section 6. It is recommended that transceiver performance be checked annually even though periodic checks are not required by the FCC. During the first year, make an additional check or two to ensure no TCXO frequency drifting has occurred.

#### 5.1.2 SURFACE-MOUNTED COMPONENTS

A large number of the components used on the transceiver board are the surface-mounted type. Since these components are relatively small in size and are soldered directly to the PC board, care must be used when they are replaced to prevent damage to the component or PC board. Surface-mounted components should not be reused because they may be damaged by the unsoldering process.

#### 5.1.3 SCHEMATIC DIAGRAMS AND COMPONENT LAYOUTS

Schematic diagrams and component layouts of the PC boards used in this transceiver are located in Section 8. A component locator guide is also provided to aid in component location.

#### 5.1.4 REPLACEMENT PARTS LIST

A replacement parts list with all the parts used in this transceiver is located in Section 7. Parts are listed alpha-numerically according to designator. For information on ordering parts, refer to Section 1.8.

#### 5.1.5 TCXO MODULE NOT SERVICEABLE

The  $\pm 1.5$  PPM TCXO module is not field serviceable. Part changes require a factory recalibration to ensure that the oscillator stays within its  $\pm 1.5$  PPM tolerance.

### 5.2 SYNTHESIZER SERVICING

---

#### 5.2.1 INTRODUCTION

When there is a synthesizer malfunction, the VCO is not locked on frequency. When an unlocked VCO is detected by the lock detector circuit, U801, pin 18 goes low (0V).

# SERVICING

---

*NOTE: The user-supplied circuitry must disable the transmitter and receiver when an out-of-lock condition is indicated.*

When the VCO is unlocked, the f<sub>R</sub> and f<sub>V</sub> inputs to the phase detector are usually not in phase (see Section 4.1.2). The phase detector in U801 then causes the VCO control voltage to go to the high or low end of its operating range. This in turn causes the VCO to oscillate at the high or low end of its frequency range.

As shown in Figure 4-1, a loop is formed by VCO Q850, amplifier Q851/Q852, and the RF IN of U801. Therefore, if any of these components begin to malfunction, improper signals appear throughout the loop. However, correct operation of the counters can still be verified by measuring the input and output frequencies to check the divide number.

Proceed as follows to check the synthesizer I/O signals to determine if it is operating properly.

## 5.2.2 REFERENCE OSCILLATOR

Check the signal at U801, pin 8. It should be 17.5 MHz at a level of approximately 1.5V P-P. If the TCXO module is defective, it is not serviceable and must be replaced with a new module as described in Section 5.1.5.

## 5.2.3 VCO

### Output Level

The output level of Q853 can be measured with an RF voltmeter or some other type of high impedance meter. The minimum level after a power splitter at R851 should be -10 dBm.

### Control Voltage

Check the DC voltage at C815 with a channel near the center of the band. If the VCO is locked on frequency, this should be a steady DC voltage near 3V. If it is not locked on frequency, it should be near the lower or upper end of its range (0V or 5.5V).

### Output Frequency

Check the VCO frequency at R851. If the VCO is locked on frequency, it should be stable on the transmit channel frequency. If the VCO is not locked on frequency, the VCO control voltage is probably near 0V or 5.5V.

## 5.2.4 SYNTHESIZER (U801)

### Lock Detector

When the VCO is locked on frequency, the lock detect output on J201, pin 7 should be high.

## 5.3 RECEIVER SERVICING

---

To isolate a receiver problem to a specific section, refer to the troubleshooting flowchart in Figure 5-1. Tests referenced in the flowchart are described in the following information.

*NOTE: Supply voltages are provided by the user.*

### 5.3.1 SUPPLY VOLTAGES AND CURRENT

Measure the supply voltages on the following pins at interface connector J201:

Pin 4 - 5.0V DC Receive

Pin 5 - 5.0V DC

Place a DC ammeter in the supply line to the transceiver and the following maximum currents should be measured:

Pin 4 - 10 mA

Pin 5 - 50 mA

### 5.3.2 MIXER/DETECTOR (U201)

#### Data Output

Using a .01  $\mu$ F coupling capacitor, inject at U241, pin 16, a 52.95 MHz, 1 mV signal, modulated with 1 kHz at  $\pm 3$  kHz deviation. The audio output level at U241, pin 9 should be approximately 400 mV RMS.

The data output on J201, pin 13 should be 600 mV to 1.2V P-P or 212 mV to 424 mV RMS with the preceding injection signal.

#### RSSI Output

The RSSI output on J201, pin 12 should be greater than 100 mV at 12 dB SINAD and less than 2.5V with 1 mV input. If either of the preceding measurements is not correct, there may be a problem with U241.

# SERVICING

---

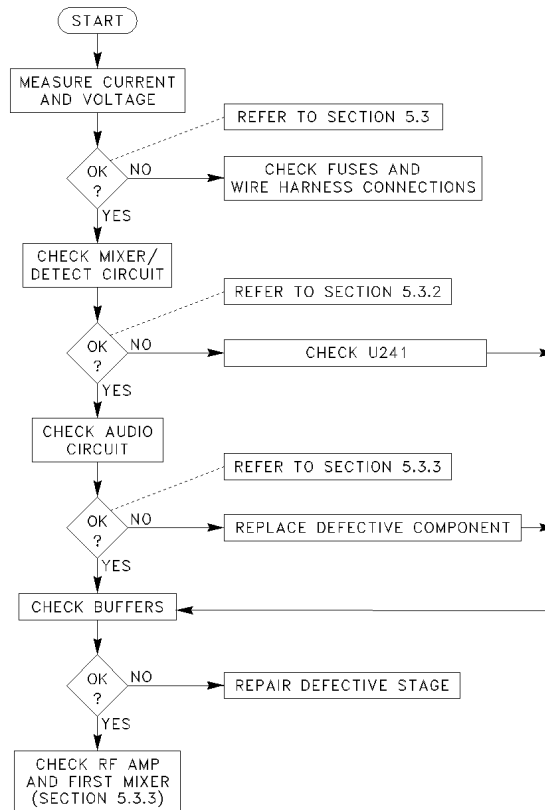

**Figure 5-1 RECEIVER SERVICING FLOWCHART**

## 5.3.3 RF AMPLIFIER (Q201) AND FIRST MIXER (Q221)

Refer to the schematic diagram for signal levels and test points for measuring levels.

## 5.3.4 RF AND IF AMPLIFIERS, FIRST MIXER

Check the DC voltages shown on the schematic diagram. If they are normal, inject a signal at the input and output of each stage using a .01  $\mu\text{F}$  coupling capacitor. If the stage is producing gain, the injection level on the input of a stage should be less than that required on the output to produce the same SINAD at the receive output.

## 5.4 TRANSMITTER SERVICING

---

### 5.4.1 SUPPLY VOLTAGES AND CURRENT

Measure the supply voltages on the following pins of interface connector J201:



- Pin 2 - 7.5V DC
- Pin 3 - 7.5V DC
- Pin 4 - 0.0V DC (while transmitting)
- Pin 5 - 5.0V DC
- Pin 6 - 2.5V DC Transmit In/1.5V P-P max

Place a DC ammeter in the supply line to the transceiver and the following maximum currents should be measured:

- Pin 2 - 650 mA
- Pin 3 - 250 mA
- Pin 5 - 12 mA

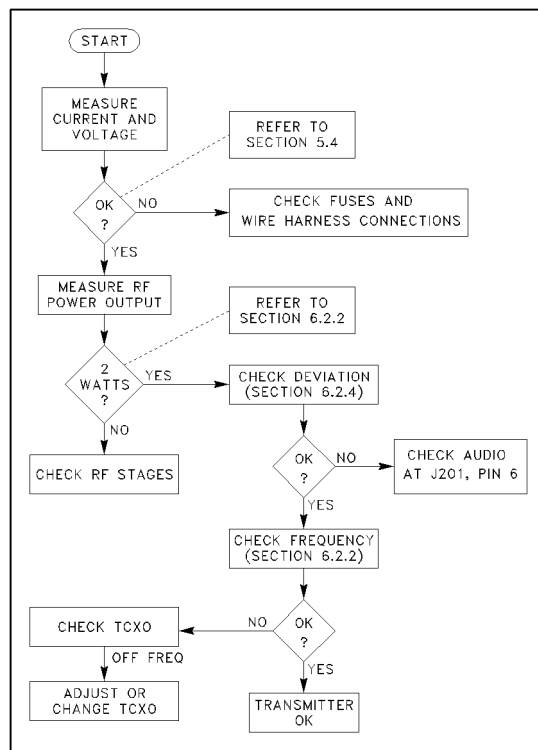

**Figure 5-2 TRANSMITTER SERVICING FLOWCHART**

# SERVICING

This page intentionally left blank.

---

## ALIGNMENT PROCEDURE AND PERFORMANCE TESTS

---

### 6.1 GENERAL

---

Receiver or transmitter alignment may be necessary if repairs are made that could affect tuning. Alignment points diagrams are located in Figure 6-3 or component layouts are located in Section 8.

Fabricate test cables by referring to Section 2.2, Interfacing with Data Equipment. This cable should include power and ground, a transmit keying switch that shorts the keying line to ground, data input and data output. The test setup must apply the various supply voltages and load the synthesizer with channel information.

### 6.2 DL3474 TRANSCEIVER ONLY

---

#### 6.2.1 FREQUENCY AND CONTROL LINE VOLTAGE CHECK

1. Connect the test setup shown in Figure 6-1. Set the power supply for +7.5V DC.
2. Load the synthesizer with the channel frequency (see Section 3.2).
3. Connect a DC voltmeter at the junction of R808/C815 to measure the VCO control line voltage for a meter reading of  $\geq 0.50$  -  $\leq 4.90$ V DC (see Figure 6-3).
4. Key the transmitter.
5. Measure the VCO control line voltage for a meter reading of  $\geq 0.75$  -  $\leq 5.00$ V DC
6. Unkey the transmitter.

#### 6.2.2 2W TRANSMITTER POWER ALIGNMENT

1. Connect the test setup shown in Figure 6-1. A DC ammeter capable of measuring up to 1.5A should be installed in the supply line.
2. Load the synthesizer with the center channel frequency.
3. Key the transmitter and make sure that the supply voltage at the RF board is 7.5V.  
**(Do not transmit for extended periods.)**
4. Adjust C553 counterclockwise for minimum current.
5. Connect a voltmeter to the junction of R542/R543.

# ALIGNMENT PROCEDURE AND PERFORMANCE TESTS

---

6. Adjust R542 clockwise for 2.30V DC (+0/-0.1V DC).
7. Readjust C553 counterclockwise for minimum current.
8. Tune C527 clockwise for maximum power.
9. Tune C553 clockwise for 2.0W ( $\pm 0.1$ W). Current should be less than 900 mA. (Power output should be 1.6-2.4W and current less than 900 mA from 403-512 MHz.)
10. Monitor the frequency with a frequency counter and adjust TCXO (Y801) for the channel frequency  $\pm 100$  Hz.

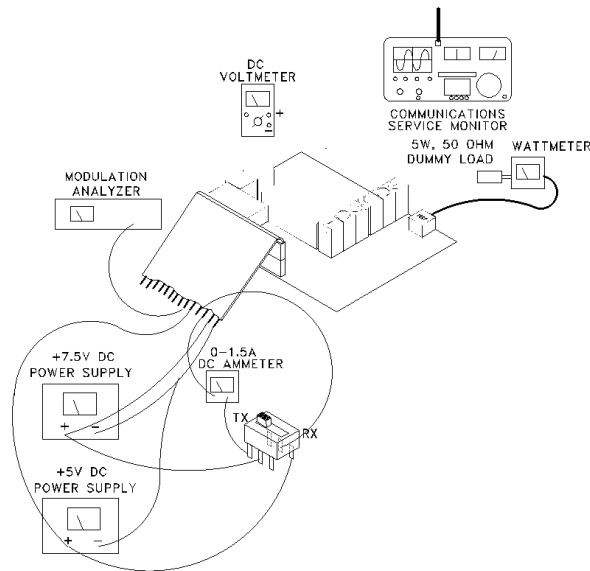

**Figure 6-1 TRANSMITTER TEST SETUP**

## 6.2.3 LOW POWER ALIGNMENT

1. Connect the test setup shown in Figure 6-1.
2. Load the synthesizer with the center channel frequency.
3. Connect a voltmeter to the junction of R542/R543.
4. Adjust R542 clockwise for -1.5V DC ( $\pm 0.1$ V DC).
5. Tune C527 clockwise for maximum power.

# ALIGNMENT PROCEDURE AND PERFORMANCE TESTS

---

6. Tune C553 clockwise for minimum power.
7. Adjust R542 for the required power level.
8. Tune C527 for power balance at frequencies which are as close as possible to  $\pm 5$  MHz from the center of the channel frequency.
9. Re-adjust R542 for the power level required if necessary.
10. Monitor the frequency with a frequency counter and adjust TCXO (Y801) for the channel frequency  $\pm 100$  Hz.

## 6.2.4 MODULATION FLATNESS ALIGNMENT

1. Inject a 220 Hz square-wave tone at approximately 0.35V P-P, biased at 2.5V DC on J201, pin 6.
2. Transmit into the modulation analyzer and observe modulation output on the oscilloscope. Set the modulation analyzer high pass filtering off and no less than a 15 kHz low pass filter.
3. Adjust R810 for a flat square-wave on the oscilloscope.
4. Inject a 1 kHz sine-wave on J201, pin 6, biased at 2.5V DC, at the level below according to the bandwidth:

0.200V RMS for 12.5 kHz BW (-X10 Radios)  
0.330V RMS for 20.0 kHz BW (-X20 Radios)  
0.400V RMS for 25.0 kHz BW (-X30 Radios)

5. Switch on TX Modulation. Set the modulation analyzer for 3 kHz low pass filtering.
6. The transmit deviation should measure between:

$\pm 1.2/\pm 1.9$  kHz for 12.5 kHz BW (-X10 Radios)  
 $\pm 1.9/\pm 3.0$  kHz for 20.0 kHz BW (-X20 Radios)  
 $\pm 2.4/\pm 3.8$  kHz for 25.0 kHz BW (-X30 Radios)

7. Set a 0 dB reference on the Audio Analyzer.
8. Input a 100 Hz sine-wave. The level should be within  $\pm 1.5$  dB of the 1 kHz reference.
9. Remove transmit modulation and unkey the transmitter.
10. Connect a DC voltmeter at the junction of R807/R855.
11. Adjust R855 to 2.10V DC ( $\pm 0.05$ V DC).

# ALIGNMENT PROCEDURE AND PERFORMANCE TESTS

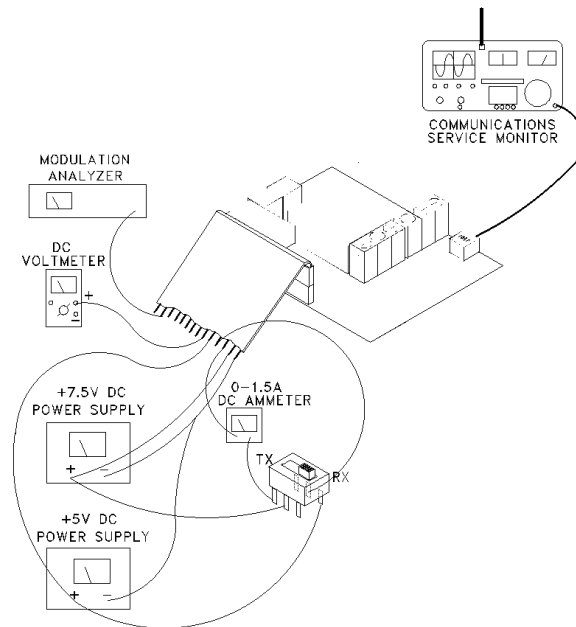

**Figure 6-2 RECEIVER TEST SETUP**

## 6.2.5 RECEIVER ALIGNMENT

**CAUTION:** Do not key the transmitter with the generator connected! Severe generator damage may result.

1. Connect the test setup shown in Figure 6-2. Adjust the power supply for +7.5V DC.
2. Measure the receive current drain. (Typically current should be <80 mA.)
3. Preset tuning slugs of L222/L224 to the full clockwise position (slug in all the way).
4. Preset C232 to center position (slot in-line with axis of part).
5. Readjust L224 counterclockwise 2 turns.

## 6.2.6 IF AND AUDIO ADJUSTMENTS

1. Load the synthesizer with the channel frequency.
2. Set the RF signal generator for this frequency with a 1 kHz tone (modulated output shown below) at a level of -47 dBm (1000  $\mu$ V) and inject into J501.

1.5 kHz deviation (-X10 12.5 kHz BW Radio)  
2.4 kHz deviation (-X20 20.0 kHz BW Radio)  
3.0 kHz deviation (-X30 25.0 kHz BW Radio)

# ALIGNMENT PROCEDURE AND PERFORMANCE TESTS

---

*NOTE: Maintain these deviation levels throughout the test when measuring AC levels, SINAD and % distortion.*

3. Adjust L242 for 2.5V DC ( $\pm 0.05$ V DC) at the receive audio output.
4. Set the RF signal generator level to -105 dBm, “unmodulated”.
5. Set the generator frequency 3 kHz below channel center (-X10) or 5 kHz below channel center (-X20/-X30).
6. Adjust C232, then L222 for peak RSSI voltage.

*NOTE: Use 2V scale on DVM.*

7. Set the RF signal generator frequency back to channel center at -47 dBm with standard deviation level.
8. Adjust L224 for minimum distortion.
9. Set the RF signal generator to -105 dBm, “unmodulated”.
10. Adjust L222 for peak RSSI voltage.

*NOTE: Use 2V scale on DVM.*

11. Adjust deviation to the level in Step 2. Record the RMS voltage level \_\_\_\_\_ RMS. (Typically 300 mV  $\pm$ 50 mV.)
12. Record the percent distortion \_\_\_\_\_%. (Typically <3%.)
13. Adjust the RF input level until 12 dB SINAD is measured. (Typically <0.45  $\mu$ V).
14. Adjust the generator RF level to -120 dBm and measure DC (RSSI) voltage on J201, pin 12. (Typically  $\leq$  0.90V DC.)
15. Adjust the generator RF level to -60 dBm and measure DC (RSSI) voltage on J201, pin 12. (Typically  $\geq$  2.40V DC.)

# ALIGNMENT PROCEDURE AND PERFORMANCE TESTS

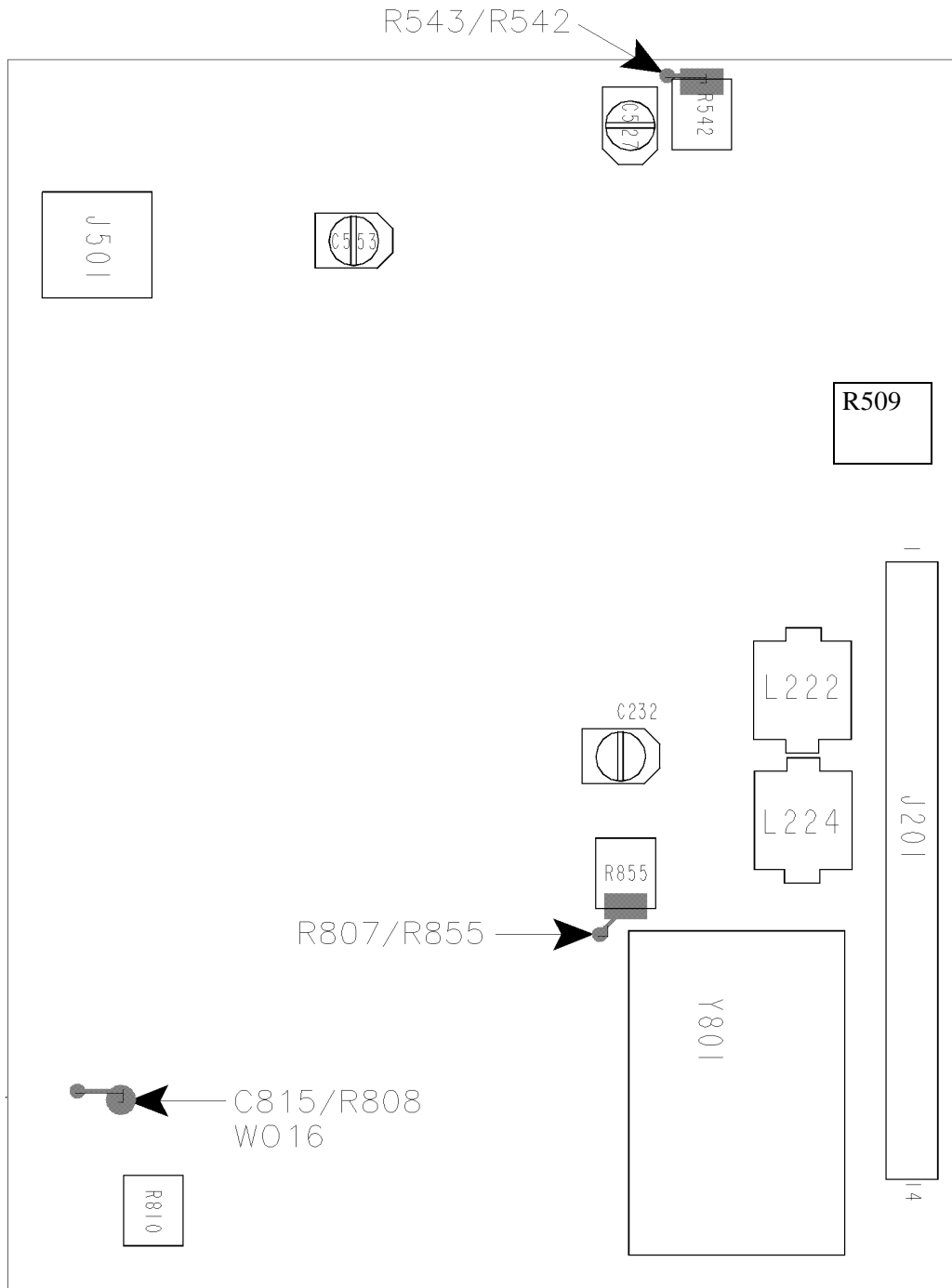

**Figure 6-3 ALIGNMENT POINTS DIAGRAM**



# SECTION 7

## PARTS LIST

. 023-3474-515

SYMBOL NUMBER	DESCRIPTION	PART NUMBER
A 801	FINISHED 450-466 VCO(M9	023-3474-540
C 101	68pF 5% NPO 0603	610-3674-680
C 102	68pF 5% NPO 0603	610-3674-680
C 103	68pF 5% NPO 0603	610-3674-680
C 104	68pF 5% NPO 0603	610-3674-680
C 105	68pF 5% NPO 0603	610-3674-680
C 106	68pF 5% NPO 0603	610-3674-680
C 107	68pF 5% NPO 0603	610-3674-680
C 108	68pF 5% NPO 0603	610-3674-680
C 109	68pF 5% NPO 0603	610-3674-680
C 110	68pF 5% NPO 0603	610-3674-680
C 111	68pF 5% NPO 0603	610-3674-680
C 112	68pF 5% NPO 0603	610-3674-680
C 113	68pF 5% NPO 0603	610-3674-680
C 114	1.0UFD 16V SMD TANT RL	610-2625-109
C 115	68pF 5% NPO 0603	610-3674-680
C 116	.01MF X7R K 0603 CHPR	610-3675-103
C 117	1.0UFD 16V SMD TANT RL	610-2625-109
C 118	68pF 5% NPO 0603	610-3674-680
C 119	68pF 5% NPO 0603	610-3674-680
C 131	1.0UFD 16V SMD TANT RL	610-2625-109
C 132	68pF 5% NPO 0603	610-3674-680
C 133	.01MF X7R K 0603 CHPR	610-3675-103
C 134	1.0UFD 16V SMD TANT RL	610-2625-109
C 135	68pF 5% NPO 0603	610-3674-680
C 201	68pF 5% NPO 0603	610-3674-680
C 203	68pF 5% NPO 0603	610-3674-680
C 204	10pF +/- .1pF NPO 0603	610-3673-100
C 205	4.7pF +/- .1pF NPO 0603	610-3673-479
C 207	68pF 5% NPO 0603	610-3674-680
C 208	68pF 5% NPO 0603	610-3674-680
C 211	68pF 5% NPO 0603	610-3674-680
C 222	.01MF X7R K 0603 CHPR	610-3675-103
C 223	3.9pf +/- .1pF NPO 0603	610-3673-399
C 224	3.0pf +/- .1pF NPO 0603	610-3673-309
C 225	.01MF X7R K 0603 CHPR	610-3675-103
C 226	.01MF X7R K 0603 CHPR	610-3675-103
C 227	8.2pF +/- .1pF NPO 0603	610-3673-829
C 228	.01MF X7R K 0603 CHPR	610-3675-103

# PARTS LIST

SYMBOL NUMBER	DESCRIPTION	PART NUMBER
C 229	.01MF X7R K 0603 CHPR	610-3675-103
C 230	.01MF X7R K 0603 CHPR	610-3675-103
C 232	1.5-5PF SMD CERAMIC	612-1602-001
C 235	.01MF X7R K 0603 CHPR	610-3675-103
C 241	.01MF X7R K 0603 CHPR	610-3675-103
C 242	.1UFD X7R J 1206 RL	610-3609-104
C 243	.1UFD X7R J 1206 RL	610-3609-104
C 245	.01MF X7R K 0603 CHPR	610-3675-103
C 246	1.0UFD 16V SMD TANT RL	610-2625-109
C 247	.01MF X7R K 0603 CHPR	610-3675-103
C 248	.01MF X7R K 0603 CHPR	610-3675-103
C 261	27pF 5% NPO 0603	610-3674-270
C 262	68pF 5% NPO 0603	610-3674-680
C 263	.1UFD X7R J 1206 RL	610-3609-104
C 265	.1UFD X7R J 1206 RL	610-3609-104
C 301	68pF 5% NPO 0603	610-3674-680
C 302	8.2pF +/- .1pF NPO 0603	610-3673-829
C 303	68pF 5% NPO 0603	610-3674-680
C 304	3.3pF +/- .1pF NPO 0603	610-3673-339
C 306	68pF 5% NPO 0603	610-3674-680
C 309	1.0UFD 16V SMD TANT RL	610-2625-109
C 310	3.3pF +/- .1pF NPO 0603	610-3673-339
C 401	.01MF X7R K 0603 CHPR	610-3675-103
C 402	.01MF X7R K 0603 CHPR	610-3675-103
C 403	.01MF X7R K 0603 CHPR	610-3675-103
C 404	.01MF X7R K 0603 CHPR	610-3675-103
C 405	82pF 5% NPO 0603	610-3674-820
C 406	6.8pF +/- .1pF NPO 0603	610-3673-689
C 407	82pF 5% NPO 0603	610-3674-820
C 410	.1UFD X7R J 1206 RL	610-3609-104
C 501	68pF 5% NPO 0603	610-3674-680
C 502	6.8pF +/- .1pF NPO 0603	610-3673-689
C 503	68pF 5% NPO 0603	610-3674-680
C 504	470pF 5% NPO 0603	610-3674-471
C 505	.01MF X7R K 0603 CHPR	610-3675-103
C 506	68pF 5% NPO 0603	610-3674-680
C 507	68pF 5% NPO 0603	610-3674-680
C 508	68pF 5% NPO 0603	610-3674-680
C 509	68pF 5% NPO 0603	610-3674-680
C 510	120pF 5% NPO 0603	610-3674-121
C 511	3.9pf +/- .1pF NPO 0603	610-3673-399
C 520	22pF 5% NPO 0603	610-3674-220
C 521	68pF 5% NPO 0603	610-3674-680
C 522	.01MF X7R K 0603 CHPR	610-3675-103
C 523	68pF 5% NPO 0603	610-3674-680
C 524	470pF 5% NPO 0603	610-3674-471
C 525	27pF 5% NPO 0603	610-3674-270
C 526	18PF NPO J 0805 CHP RL (L	610-3601-180
C 527	2.5-10PF SMD CERAMIC	612-1602-002
C 528	10pF +/- .1pF NPO 0603	610-3673-100

# PARTS LIST

SYMBOL NUMBER	DESCRIPTION	PART NUMBER
C 541	68pF 5% NPO 0603	610-3674-680
C 542	470pF 5% NPO 0603	610-3674-471
C 546	68pF 5% NPO 0603	610-3674-680
C 547	68pF 5% NPO 0603	610-3674-680
C 548	1.0UFD 16V SMD TANT RL	610-2625-109
C 549	.01MF X7R K 0603 CHPR	610-3675-103
C 550	33PF NPO J 0805 CHP RL (L	610-3601-330
C 551	15PF NPO J 0805CHP RL (L0	610-3601-150
C 552	3.9PF NPO J 0805CHP RL	610-3601-399
C 553	2.5-10PF SMD CERAMIC	612-1602-002
C 554	68pF 5% NPO 0603	610-3674-680
C 555	33pF 5% NPO 0603	610-3674-330
C 560	22pF 5% NPO 0603	610-3674-220
C 561	5.6PF NPO J 0805CHP RL (L	610-3601-569
C 562	6.2PF NPO J0805 CHP RL	610-3601-629
C 563	7.5PF NPO J0805 CHP RL	610-3601-759
C 564	.01MF X7R K 0603 CHPR	610-3675-103
C 565	68pF 5% NPO 0603	610-3674-680
C 567	5.6PF NPO J 0805CHP RL (L	610-3601-569
C 568	47pF 5% NPO 0603	610-3674-470
C 569	5.1PF NPO J0805 CHP RL	610-3601-519
C 570	33pF 5% NPO 0603	610-3674-330
C 571	68pF 5% NPO 0603	610-3674-680
C 572	.01MF X7R K 0603 CHPR	610-3675-103
C 573	1.0UFD 16V SMD TANT RL	610-2625-109
C 801	.01MF X7R K 0603 CHPR	610-3675-103
C 802	.01MF X7R K 0603 CHPR	610-3675-103
C 803	.01MF X7R K 0603 CHPR	610-3675-103
C 804	3.3pF +/- .1pF NPO 0603	610-3673-339
C 805	.01MF X7R K 0603 CHPR	610-3675-103
C 806	68pF 5% NPO 0603	610-3674-680
C 807	.01MF X7R K 0603 CHPR	610-3675-103
C 808	68pF 5% NPO 0603	610-3674-680
C 809	100PF NPO J 0805CHP RL (L	610-3601-101
C 810	.1UFD X7R J 1206 RL	610-3609-104
C 811	.001uF 10% X7R 0603	610-3675-102
C 812	.0047UF X7R K 0805 C/R (L	610-3605-472
C 813	.001uF 10% X7R 0603	610-3675-102
C 814	1.0UFD 16V SMD TANT RL	610-2625-109
C 815	.0047UF X7R K 0805 C/R (L	610-3605-472
C 817	68pF 5% NPO 0603	610-3674-680
C 818	1.0UFD 16V SMD TANT RL	610-2625-109
C 819	3.9pf +/- .1pF NPO 0603	610-3673-399
C 831	.01MF X7R K 0603 CHPR	610-3675-103
C 832	.01MF X7R K 0603 CHPR	610-3675-103
C 833	68pF 5% NPO 0603	610-3674-680
C 834	4.7UFD 10V SMD TANT RL	610-2624-479
C 835	.01MF X7R K 0603 CHPR	610-3675-103
C 836	.01MF X7R K 0603 CHPR	610-3675-103
C 837	.01MF X7R K 0603 CHPR	610-3675-103

# PARTS LIST

SYMBOL NUMBER	DESCRIPTION	PART NUMBER
C 838	68pF 5% NPO 0603	610-3674-680
C 839	.01MF X7R K 0603 CHPR	610-3675-103
C 840	.01MF X7R K 0603 CHPR	610-3675-103
C 841	68pF 5% NPO 0603	610-3674-680
C 842	.01MF X7R K 0603 CHPR	610-3675-103
C 844	1.0UFD 16V SMD TANT RL	610-2625-109
C 845	.01MF X7R K 0603 CHPR	610-3675-103
C 846	68pF 5% NPO 0603	610-3674-680
C 847	.01MF X7R K 0603 CHPR	610-3675-103
C 848	68pF 5% NPO 0603	610-3674-680
C 849	68pF 5% NPO 0603	610-3674-680
C 850	68pF 5% NPO 0603	610-3674-680
C 851	68pF 5% NPO 0603	610-3674-680
C 852	68pF 5% NPO 0603	610-3674-680
C 855	.01MF X7R K 0603 CHPR	610-3675-103
CR 201	SWITCHING DIODE SOT-23	623-1504-002
CR 561	SOT PIN SW DIODE T/RL	623-1504-001
CR 562	SOT PIN SW DIODE T/RL	623-1504-001
CR 831	DUAL SW DIODE SOT23	623-1504-023
CR 832	BB535 SOD 323 VARACTOR	623-5005-022
EP 200	MINI CER CRY PIN INSUL	010-0345-280
EP 501	FERRITE BEAD SMD	617-2503-001
EP 541	FERRITE BEAD SMD	617-2503-001
J 201	14P SGL ROW RCPT.1CNTR	615-7110-214
J 501	STR TERM PCB	615-3013-030
L 201	INDUCT LL2012 F8.2N 0805	642-9003-826
L 202	22 NHY0805 SMD 10% INDUCT	642-9003-227
L 222	1+/-6%UH VAR. IND. 5MM	642-1012-015
L 223	0.82 MHY SMD INDUCTOR	642-9001-828
L 224	1+/-6%UH VAR. IND. 5MM	642-1012-015
L 242	QUAD COIL 68OUH//180PF SM	642-5102-001
L 301	10 NHY0805 SMD 10% INDUCT	642-9003-107
L 302	INDUCT LL2012 F15N 0805 S	642-9003-157
L 401	.100 UHY SMD INDUCTOR	642-9001-108
L 402	.100 UHY SMD INDUCTOR	642-9001-108
L 404	1.0 UHY SMD INDUCTOR	642-9001-109
L 501	INDUCT LL2012 F15N 0805 S	642-9003-157
L 502	1.0 UHY SMD INDUCTOR	642-9001-109
L 503	INDUCT LL2012 F15N 0805 S	642-9003-157
L 521	10T 43.0nh SMD AIR CORE I	642-0030-010
L 522	INDUCT LL2012 F3N3 0805 S	642-9003-336
L 541	5T 18.5nh SMD AIR CORE IN	642-0030-005
L 561	5T 18.5nh SMD AIR CORE IN	642-0030-005
L 562	9T 35.5nh SMD AIR CORE IN	642-0030-009
L 563	9T 35.5nh SMD AIR CORE IN	642-0030-009
L 564	5T 18.5nh SMD AIR CORE IN	642-0030-005
L 565	1.0 UHY SMD INDUCTOR	642-9001-109
L 566	12.5nH SM AIR CORE IND (L	642-0030-004
L 801	39 NHY0805 SMD 10% INDUCT	642-9003-397
L 851	1.0 UHY SMD INDUCTOR	642-9001-109

# PARTS LIST

SYMBOL NUMBER	DESCRIPTION	PART NUMBER
MP 801	CAN-VCO 3474	017-2225-751
MP 802	TOP SHIELD 3474 XMIT	017-2225-761
MP 803	SHIELD 3474 BOTTOM XMIT	017-2225-762
MP 804	3474 SHIELD BOTTOM SYNTH	017-2225-763
MP 806	XTAL FLTR SHIELD 3472	017-2225-699
PC 001	PCB DL 3474 MAIN (MUL6)	035-3474-030
Q 101	NPN TRANS SOT 23 80V	676-0003-616
Q 102	DIG TRANS DCT114WK S23	676-0003-621
Q 103	NPN TRANS SOT 23 80V	676-0003-616
Q 131	NPN TRANS SOT 23 80V	676-0003-616
Q 201	MMBR5031 SOT23NPN XSTR	676-0003-606
Q 221	VHF/UHF AMP SOT-23	676-0003-634
Q 222	SOT SI N-CHAN JFET	676-0006-019
Q 301	IV (NPN) 85633 SOT23 R25	676-0003-636
Q 401	VHF/UHF AMP SOT-23	676-0003-634
Q 501	IV (NPN) 85633 SOT23 R25	676-0003-636
Q 521	NPN SO8 .2-2GHZ XSTR	676-0003-604
Q 541	RF FET TRANS	676-0006-450
Q 831	NPN TRANS SOT 23 80V	676-0003-616
Q 832	NPN SC70 MSD1819 GEN PURP	676-0013-701
Q 833	VHF/UHF AMP SOT-23	676-0003-634
Q 834	DIG TRANS DCT114WK S23	676-0003-621
Q 851	BIPOLAR MMIC, SOT143	676-0003-640
R 120	100k OHMS J 063W 0603 CHI	669-0155-104
R 131	100k OHMS J 063W 0603 CHI	669-0155-104
R 201	47 OHMS J 063W 0603 CHIP	669-0155-470
R 202	2.7K OHM J 063W 0603 CHIP	669-0155-272
R 203	750 OHM RES J 063W 0603 C	669-0155-751
R 204	330 OHMS J 063W 0603 CHIP	669-0155-331
R 222	330 OHMS J 063W 0603 CHIP	669-0155-331
R 223	22K OHMS J 063W 0603 CHIP	669-0155-223
R 224	1K OHM J 063W 0603 CHIP	669-0155-102
R 225	15k OHMS J 063W 0603 CHIP	669-0155-153
R 226	470 OHMS J 063W 0603 CHIP	669-0155-471
R 228	10 OHMS J 063W 0603 CHIP	669-0155-100
R 229	330 OHMS J 063W 0603 CHIP	669-0155-331
R 230	2.7K OHM J 063W 0603 CHIP	669-0155-272
R 241	62K OHMS J 063W 0603 CHIP	669-0155-623
R 242	27K OHMS J 063W 0603 CHIP	669-0155-273
R 243	270 OHMS J 063W 0603 CHIP	669-0155-271
R 261	200k OHMS J 063W 0603 CHI	669-0155-204
R 262	100k OHMS J 063W 0603 CHI	669-0155-104
R 263	10K OHMS J 063W 0603 CHIP	669-0155-103
R 264	18k OHMS J 063W 0603 CHIP	669-0155-183
R 265	10 OHMS J 063W 0603 CHIP	669-0155-100
R 267	12K OHMSJ 063W 0603 CHIP	669-0155-123
R 268	10K OHMS J 063W 0603 CHIP	669-0155-103
R 269	10K OHMS J 063W 0603 CHIP	669-0155-103
R 270	10K OHMS J 063W 0603 CHIP	669-0155-103
R 271	10K OHMS J 063W 0603 CHIP	669-0155-103

# PARTS LIST

SYMBOL NUMBER	DESCRIPTION	PART NUMBER
R 301	3.3K OHM J 063W 0603 CHIP	669-0155-332
R 302	1.8K OHMS J 063W 0603 CHI	669-0155-182
R 303	180 OHMS J 063W 0603 CHIP	669-0155-181
R 304	470 OHMS J 063W 0603 CHIP	669-0155-471
R 401	10 OHMS J 063W 0603 CHIP	669-0155-100
R 402	15k OHMS J 063W 0603 CHIP	669-0155-153
R 403	4.7K OHM J 063W 0603 CHIP	669-0155-472
R 404	680 OHMS J 063W 0603 CHIP	669-0155-681
R 501	2.2K OHMS J 063W 0603 CHI	669-0155-222
R 502	1.8K OHMS J 063W 0603 CHI	669-0155-182
R 503	10 OHMS J 063W 0603 CHIP	669-0155-100
R 504	560 OHMS J 063W 0603 CHIP	669-0155-561
R 506	100 OHMS J 063W 0603 CHIP	669-0155-101
R 508	ZERO OHM J 0805 CHIP/R	669-0105-001
R 509	470 OHM SMD TRIMMER	662-0130-471
R 521	1K OHM J 063W 0603 CHIP	669-0155-102
R 522	150 OHMS J 063W 0603 CHIP	669-0155-151
R 524	220 OHMS J 063W 0603 CHIP	669-0155-221
R 541	10 OHMS J 063W 0603 CHIP	669-0155-100
R 542	10K OHM SMD TRIMMER	662-0130-103
R 543	10K OHMS J 063W 0603 CHIP	669-0155-103
R 546	47 OHMS J 063W 0603 CHIP	669-0155-470
R 550	10 OHMS J 063W 0603 CHIP	669-0155-100
R 551	10 OHMS J 063W 0603 CHIP	669-0155-100
R 562	RES 270R 0.75W +/-5% (L07	669-0135-271
R 564	47K OHMS J 063W 0603 CHIP	669-0155-473
R 801	10K OHMS J 063W 0603 CHIP	669-0155-103
R 802	10K OHMS J 063W 0603 CHIP	669-0155-103
R 804	10 OHMS J 063W 0603 CHIP	669-0155-100
R 805	27K OHMS J 063W 0603 CHIP	669-0155-273
R 806	12K OHMSJ 063W 0603 CHIP	669-0155-123
R 807	4.7K OHM J 063W 0603 CHIP	669-0155-472
R 808	18k OHMS J 063W 0603 CHIP	669-0155-183
R 810	220K OHM SMD TRIMMER	662-0130-224
R 811	27K OHMS J 063W 0603 CHIP	669-0155-273
R 812	10K OHMS J 063W 0603 CHIP	669-0155-103
R 813	100k OHMS J 063W 0603 CHI	669-0155-104
R 814	20 OHM J 063W 0603 CHIP	669-0155-200
R 817	4.7K OHM J 063W 0603 CHIP	669-0155-472
R 831	10K OHMS J 063W 0603 CHIP	669-0155-103
R 834	10K OHMS J 063W 0603 CHIP	669-0155-103
R 835	100 OHMS J 063W 0603 CHIP	669-0155-101
R 836	4.7K OHM J 063W 0603 CHIP	669-0155-472
R 838	100 OHMS J 063W 0603 CHIP	669-0155-101
R 839	1K OHM J 063W 0603 CHIP	669-0155-102
R 840	22K OHMS J 063W 0603 CHIP	669-0155-223
R 841	15k OHMS J 063W 0603 CHIP	669-0155-153
R 842	1K OHM J 063W 0603 CHIP	669-0155-102
R 844	680 OHMS J 063W 0603 CHIP	669-0155-681
R 845	18 OHMS J 063W 0603 CHIP	669-0155-180

# PARTS LIST

SYMBOL NUMBER	DESCRIPTION	PART NUMBER
R 846	18 OHMS J 063W 0603 CHIP	669-0155-180
R 847	18 OHMS J 063W 0603 CHIP	669-0155-180
R 848	1.5K OHM J 063W 0603 CHIP	669-0155-152
R 851	150 OHMS J 063W 0603 CHIP	669-0155-151
R 852	39 OHM J 0603 CHIP/R	669-0155-390
R 853	150 OHMS J 063W 0603 CHIP	669-0155-151
R 854	82 OHMS 5% 063W 0603 SMD	669-0155-820
R 855	100K SMD TRIMMER	662-0130-104
R 856	4.7K OHM J 063W 0603 CHIP	669-0155-472
R 857	4.7K OHM J 063W 0603 CHIP	669-0155-472
R 858	4.7K OHM J 063W 0603 CHIP	669-0155-472
R 860	100 OHMS J 063W 0603 CHIP	669-0155-101
RE 000	SCHEMATIC DL 3474 MAIN	025-3474-030
RE 000	SCHEMATIC DL 3474 MAIN	025-3474-030
RE 000	ASSEMBLY DL 3474 MAIN BD	027-3474-030
RM 000	SLDR 62/36/2 H20 CLEAN	684-1606-062
U 101	5.5V REG 50-6	644-2603-086
U 131	5.5V REG 50-6	644-2603-086
U 221	DBL BAL MIXER MOT-1-04	644-0007-014
U 241	FM IF MC3371D SO-16	644-2002-031
U 261	MC33172D SO8 OP AMP	644-2019-017
U 801	FRACTIONAL-N SYNTHESIZER	644-3954-027
Y 801	17.5 MHZ TCXO +/-1.5 PPM	618-7009-521
Z 201	SMD HEL FLTR 459 MHZ 3 PO	632-1005-044
Z 202	SMD HEL FLTR 459 MHZ 3 PO	632-1005-044
Z 221	52.95MHZ 4P 8KHZ BW	632-0009-011
Z 241	450 KHZ, 9 KHZ BW CERAMIC	632-2004-015
Z 242	450 KHZ, 9 KHZ BW CERAMIC	632-2004-015

## 023-3474-542

C 850	68pF 5% NPO 0603	610-3674-680
C 851	68pF 5% NPO 0603	610-3674-680
C 852	8.2pF +/- .1pF NPO 0603	610-3673-829
C 853	9.1pf +/- .1pF NPO 0603	610-3673-919
C 854	100pF 5% NPO 0603	610-3674-101
C 855	68pF 5% NPO 0603	610-3674-680
C 856	2.7pF +/- .1pF NPO 0603	610-3673-279
C 858	68pF 5% NPO 0603	610-3674-680
C 859	7.5pF +/- .1pF NPO 0603	610-3673-759
C 861	8.2pF +/- .1pF NPO 0603	610-3673-829
C 862	6.8pF +/- .1pF NPO 0603	610-3673-689
C 863	68pF 5% NPO 0603	610-3674-680
C 864	10pF +/- .1pF NPO 0603	610-3673-100
C 865	68pF 5% NPO 0603	610-3674-680
C 866	68pF 5% NPO 0603	610-3674-680
C 867	68pF 5% NPO 0603	610-3674-680
C 868	1.5pF +/- .1pF NPO 0603	610-3673-159
C 870	1pF +/- .1pF NPO 0603	610-3673-109
C 871	100pF 5% NPO 0603	610-3674-101

# PARTS LIST

SYMBOL NUMBER	DESCRIPTION	PART NUMBER
C 873	100pF 5% NPO 0603	610-3674-101
C 874	3.3pF +/- .1pF NPO 0603	610-3673-339
C 876	8.2pF +/- .1pF NPO 0603	610-3673-829
C 877	1pF +/- .1pF NPO 0603	610-3673-109
C 878	10PF NPO J 0805 CHP RL	610-3601-100
CR 850	SOT PIN SW DIODE T/RL	623-1504-001
CR 851	BB535 SOD 323 VARACTOR	623-5005-022
CR 852	VAR DIODE SOD123 BB515	623-5005-020
CR 853	VAR DIODE SOD123 BB515	623-5005-020
CR 854	BB535 SOD 323 VARACTOR	623-5005-022
CR 855	BB535 SOD 323 VARACTOR	623-5005-022
CR 856	BB535 SOD 323 VARACTOR	623-5005-022
L 851	150 NHY0805 SMD 10% IN	642-9003-158
L 852	150 NHY0805 SMD 10% IN	642-9003-158
L 853	22 NHY0805 SMD 10% IND	642-9003-227
L 854	150 NHY0805 SMD 10% IN	642-9003-158
L 855	INDUCT LL2012 F56N 080	642-9003-567
L 856	22 NHY0805 SMD 10% IND	642-9003-227
Q 850	NPN TRANS NE85619 SC90	676-0003-651
Q 851	NPN TRANS NE85619 SC90	676-0003-651
Q 852	NPN TRANS NE85619 SC90	676-0003-651
Q 853	NPN TRANS NE85619 SC90	676-0003-651
R 851	10K OHMS J 063W 0603 C	669-0155-103
R 852	47K OHMS J 063W 0603 C	669-0155-473
R 853	47K OHMS J 063W 0603 C	669-0155-473
R 854	10 OHMS J 063W 0603 CH	669-0155-100
R 856	10 OHMS J 063W 0603 CH	669-0155-100
R 857	6.8K OHM J 063W 0603 C	669-0155-682
R 858	1K OHM J 063W 0603 CHI	669-0155-102
R 862	10K OHMS J 063W 0603 C	669-0155-103
R 863	10 OHMS J 063W 0603 CH	669-0155-100
R 864	10K OHMS J 063W 0603 C	669-0155-103
R 865	10K OHMS J 063W 0603 C	669-0155-103
R 866	470 OHMS J 063W 0603 C	669-0155-471
R 867	12K OHMSJ 063W 0603 CH	669-0155-123
R 868	390 OHMS J 063W 0603 C	669-0155-391
R 869	270 OHMS J 063W 0603 C	669-0155-271
R 870	18 OHMS J 063W 0603 CH	669-0155-180
R 871	3.9K OHM J 063W 0603 C	669-0155-392
R 872	1.8K OHMS J 063W 0603	669-0155-182
R 874	680 OHMS J 063W 0603 C	669-0155-681
R 875	270 OHMS J 063W 0603 C	669-0155-271
RM 000	SLDR 62/36/2 H20 CLEAN	684-1606-062
Z 850	0.5IN LONG SMD RESONAT	642-9004-005

## 023-3474-511

C 225	.01MF X7R K 0603 CHPR	610-3675-103
C 227	8.2pF +/- .1pF NPO 0603	610-3673-829



# PARTS LIST

EP 200	MINI CER CRY PIN INSUL	010-0345-280
J 201	14P SGL ROW RCPT.1CNTR	615-7110-214
J 501	STR TERM PCB	615-3013-030
L 222	1+/-6%UH VAR. IND. 5MM	642-1012-015
L 224	1+/-6%UH VAR. IND. 5MM	642-1012-015
MP 801	CAN-VCO 3474	017-2225-751
MP 802	TOP SHIELD 3474 XMIT	017-2225-761
MP 803	SHIELD 3474 BOTTOM XMIT	017-2225-762
MP 804	3474 SHIELD BOTTOM SYNTH	017-2225-763
MP 806	XTAL FLTR SHIELD 3472	017-2225-699
R 230	2.7K OHM J 063W 0603 CHIP	669-0155-272
R 261	200k OHMS J 063W 0603 CHI	669-0155-204
RE 000	SCHEMATIC DL 3474 MAIN	025-3474-030
RE 000	ASSEMBLY DL 3474 MAIN BD	027-3474-030
Y 801	17.5 MHZ TCXO +/-1.5 PPM	618-7009-521
Z 221	52.95MHZ 4P 8KHZ BW	632-0009-011
Z 241	450 KHZ, 9 KHZ BW CERAMIC	632-2004-015
Z 242	450 KHZ, 9 KHZ BW CERAMIC	632-2004-015

## 023-3474-521

C 225	39pF 5% NPO 0603	610-3674-390
C 227	10pF +/- .1pF NPO 0603	610-3673-100
EP 200	MINI CER CRY PIN INSUL	010-0345-280
J 201	14P SGL ROW RCPT.1CNTR	615-7110-214
J 501	STR TERM PCB	615-3013-030
L 222	1+/-6%UH VAR. IND. 5MM	642-1012-015
L 224	1+/-6%UH VAR. IND. 5MM	642-1012-015
MP 801	CAN-VCO 3474	017-2225-751
MP 802	TOP SHIELD 3474 XMIT	017-2225-761
MP 803	SHIELD 3474 BOTTOM XMIT	017-2225-762
MP 804	3474 SHIELD BOTTOM SYNTH	017-2225-763
MP 806	XTAL FLTR SHIELD 3472	017-2225-699
R 230	1.8K OHMS J 063W 0603 CHI	669-0155-182
R 261	120K OHM J 063W 0603 CHIP	669-0155-124
RE 000	SCHEMATIC DL 3474 MAIN	025-3474-030
RE 000	ASSEMBLY DL 3474 MAIN BD	027-3474-030
Y 801	17.5 MHZ TCXO +/-1.5 PPM	618-7009-521
Z 221	52.95MHZ 4P 15KHZ BW	632-0009-009
Z 241	CERAMIC DATA FILTER 450KH	632-2004-016
Z 242	CERAMIC DATA FILTER 450KH	632-2004-016

## 023-3474-531

C 225	39pF 5% NPO 0603	610-3674-390
-------	------------------	--------------

# PARTS LIST

---

C 227	10pF +/- .1pF NPO 0603	610-3673-100
EP 200	MINI CER CRY PIN INSUL	010-0345-280
J 201	14P SGL ROW RCPT.1CNTR	615-7110-214
J 501	STR TERM PCB	615-3013-030
L 222	1+/-6%UH VAR. IND. 5MM	642-1012-015
L 224	1+/-6%UH VAR. IND. 5MM	642-1012-015
MP 801	CAN-VCO 3474	017-2225-751
MP 802	TOP SHIELD 3474 XMIT	017-2225-761
MP 803	SHIELD 3474 BOTTOM XMIT	017-2225-762
MP 804	3474 SHIELD BOTTOM SYNTH	017-2225-763
MP 806	XTAL FLTR SHIELD 3472	017-2225-699
R 230	1.8K OHMS J 063W 0603 CHI	669-0155-182
R 261	100k OHMS J 063W 0603 CHI	669-0155-104
RE 000	SCHEMATIC DL 3474 MAIN	025-3474-030
RE 000	ASSEMBLY DL 3474 MAIN BD	027-3474-030
Y 801	17.5 MHZ TCXO +/-1.5 PPM	618-7009-521
Z 221	52.95MHZ 4P 15KHZ BW	632-0009-009
Z 241	450 KHZ, 20 KHZ BW CERAMI	632-2004-013
Z 242	450 KHZ, 20 KHZ BW CERAMI	632-2004-013

This parts list applies to Band 5 transceivers.

## SCHEMATIC AND COMPONENT LAYOUTS

TRANSISTOR AND DIODE BASING REFERENCE TABLE		
TRANSISTORS		
Part Number	Basing Diagram	Identification
676-0003-604	2	3604
676-0003-616	1	26
676-0003-621	1	74
676-0003-634	1	3B
676-0003-636	1	R25
676-0003-640	3	-
676-0003-651	1	24
676-0006-450	4	-
676-0013-701	1	1R
DIODES		
623-1504-001	-	4D
623-1504-002	-	5A
623-1504-023	-	A7
623-5005-020	-	S
623-5005-022	-	S

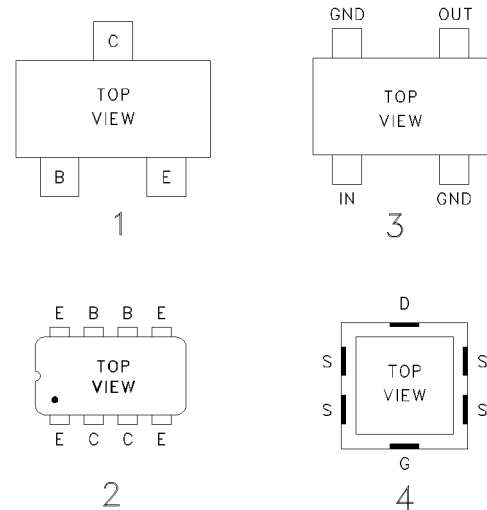

## INTEGRATED CIRCUITS

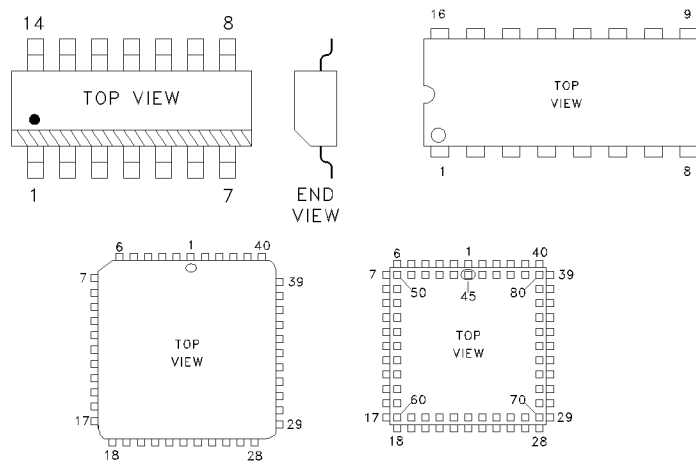

# SCHEMATICS AND COMPONENT LAYOUTS

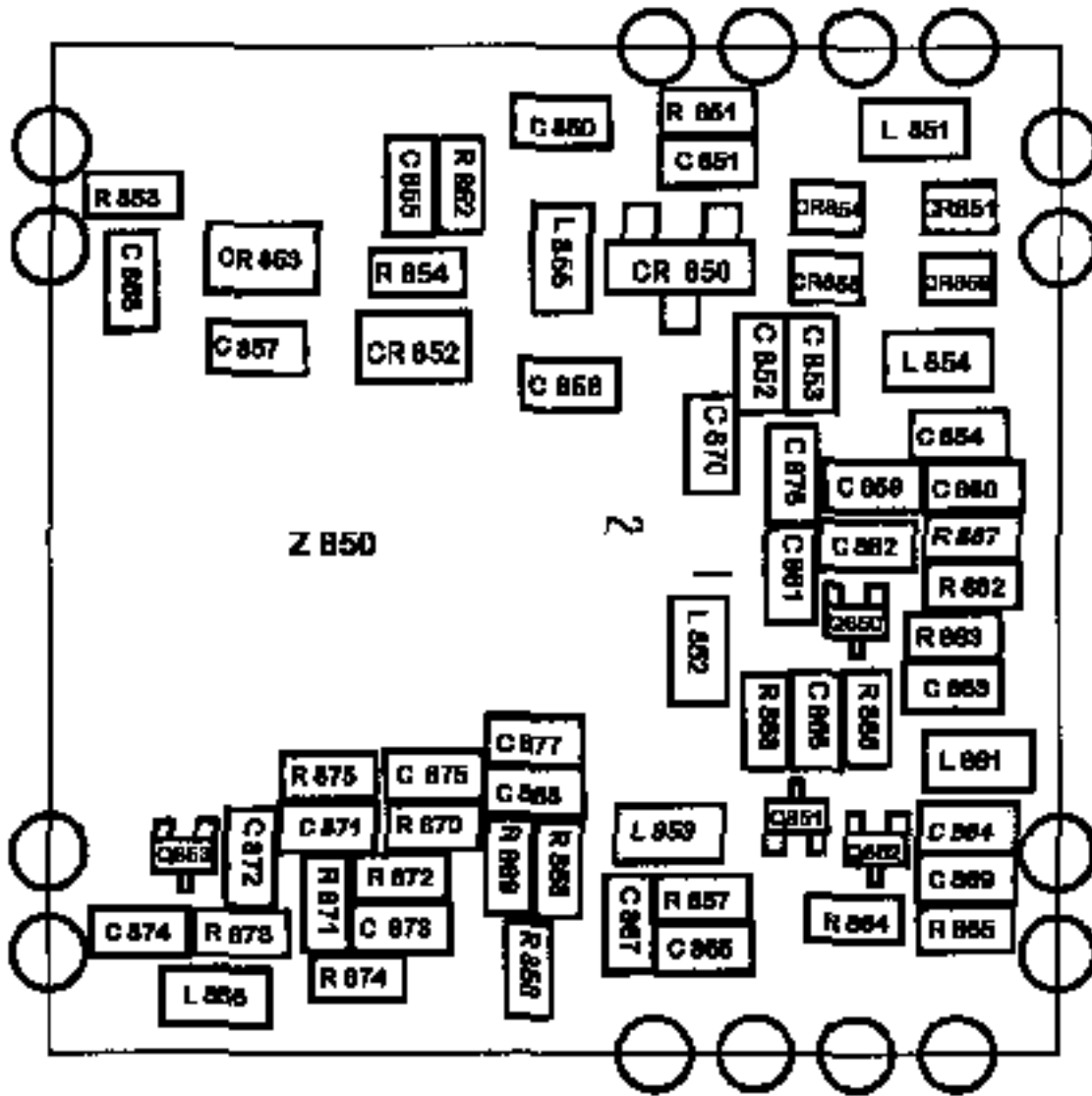

Figure 8-1 VCO COMPONENT LAYOUT (COMPONENT SIDE VIEW)

# SCHEMATICS AND COMPONENT LAYOUTS

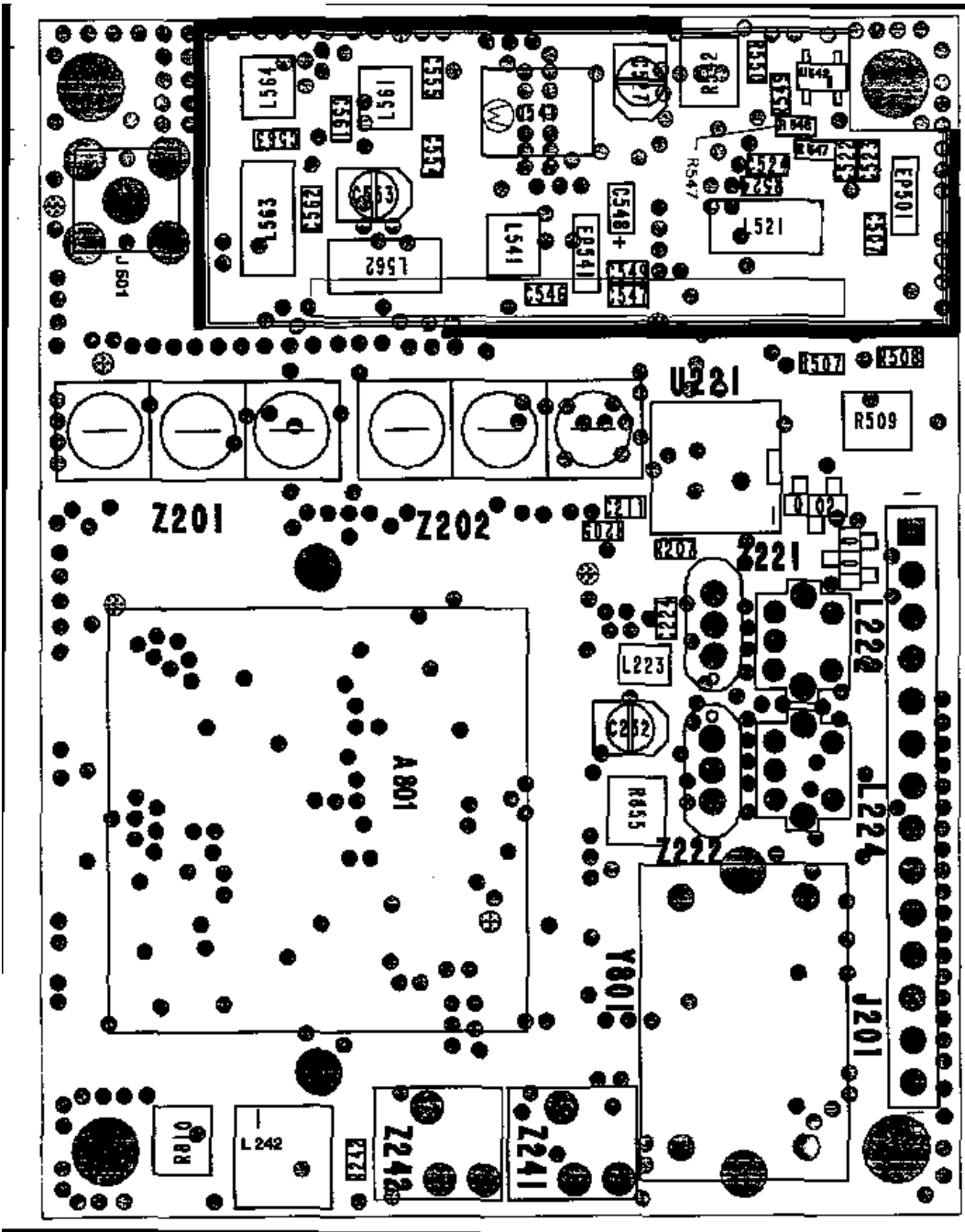

Figure 8-2 TRANSCEIVER COMPONENT LAYOUT (COMPONENT SIDE VIEW)

# SCHEMATICS AND COMPONENT LAYOUTS

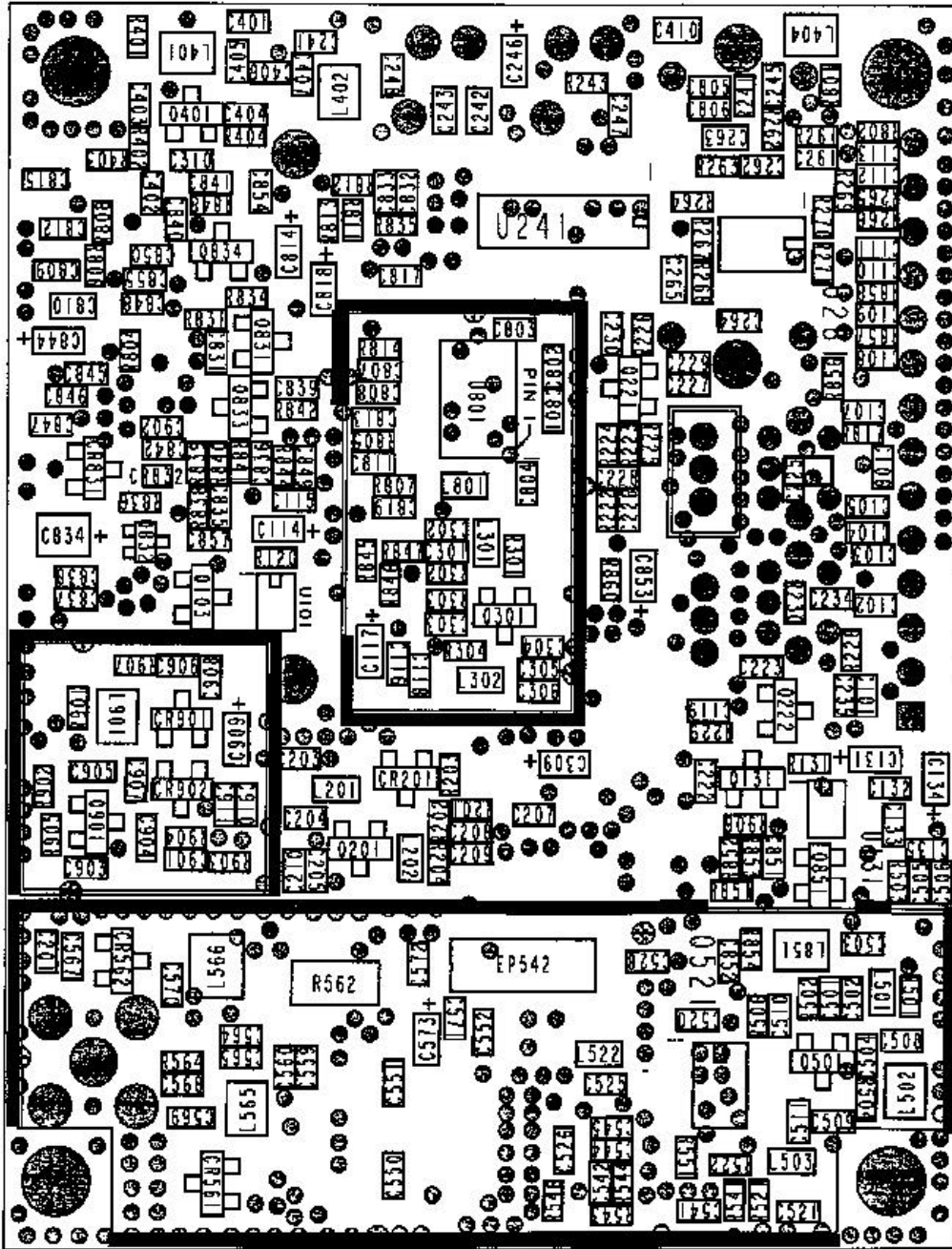

Figure 8-3 TRANSCEIVER COMPONENT LAYOUT (OPPOSITE COMPONENT SIDE VIEW)

# SCHEMATICS AND COMPONENT LAYOUTS

---

**Figure 8-4 DM-3474 SCHEMATIC**

Company Confidential

Copyright 1998 Johnson Data Telemetry Corporation

# SCHEMATICS AND COMPONENT LAYOUTS

---

This page intentionally left blank.