



Very Well Connected™

# INSTALLATION INSTRUCTIONS

## Product

**7160-0486, 7160-0487**

**FZ-G1 DOCKING STATION**

## Revision

Rev .B

## Form

INST-596

**Printing Spec: PS-001**

This instruction sheet is for the FZ-G1 docking station only. For instructions on features, set-up, and operation of the FZ-G1 computer, please refer to the manual provided by Panasonic with the computer.

This docking station is designed to be used with a variety of Gamber-Johnson mounting systems. Installation instructions for other Gamber-Johnson products are provided with each individual product.

This instruction sheet is for the following products:

- Item No. 7160-0486-00(-P)(-E)** Keyed alike, No RF
- Item No. 7160-0486-02(-P)(-E)** Keyed alike, Dual RF
- Item No. 7160-0486-03(-P)(-E)** Keyed different, No RF
- Item No. 7160-0486-04(-P)(-E)** Keyed different, Dual RF
  
- Item No. 7160-0487-00(-P)(-E)** Keyed alike, No RF
- Item No. 7160-0487-02(-P)(-E)** Keyed alike, Dual RF
- Item No. 7160-0487-03(-P)(-E)** Keyed different, No RF
- Item No. 7160-0487-04(-P)(-E)** Keyed different, Dual RF

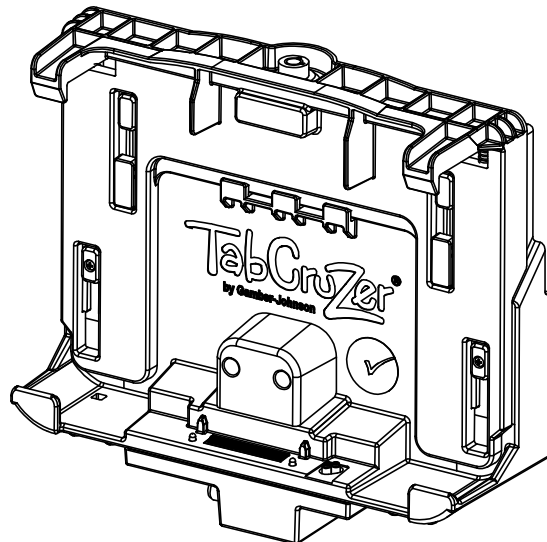

### Product Mounting Disclaimer

Gamber-Johnson is not liable under any theory of contract or tort law for any loss, damage, personal injury, special, incidental or consequential damages for personal injury or other damage of any nature arising directly or indirectly as a result of the improper installation or use of its products in vehicle or any other application. In order to safely install and use Gamber-Johnson products full consideration of vehicle occupants, vehicle systems (i.e., the location of fuel lines, brakes lines, electrical, drive train or other systems), air-bags and other safety equipment is required. Gamber-Johnson specifically disclaims any responsibility for the improper use or installation of its products not consistent with the original vehicle manufactures specifications and recommendations, Gamber-Johnson product instruction sheets, or workmanship standards as endorsed through the Gamber-Johnson Certified Installer Program.

© Copyright 2012 Gamber-Johnson, LLC

If you need assistance or have questions, call Gamber-Johnson at 1-800-456-6868

# PRE-INSTALLATION RECOMMENDATIONS

## Conduct a "Bench Test"

Gamber-Johnson strongly advises a "bench test" be conducted to verify all electronic and software issues are resolved prior to installation:

1. Make sure the computer is operational by itself.
2. Insert computer into the docking station and verify that the computer is operating in the dock.
3. Interconnect entire assembly and verify start-up of all components, including other equipment (printers, modems, scanners, etc.)

*Gamber-Johnson recommends positioning of all mounts and equipment in the vehicle prior to the actual install to verify that mounting locations are safe and practical.*

## IMPORTANT SAFETY INFORMATION FOR INSTALLERS

Safety is dependent on the proper installation and servicing of this docking station. It is important to read and follow all instructions before installing this product.

To properly install a Gamber-Johnson docking station you must have a good understanding of automotive electrical procedures and systems, along with proficiency in the installation and service of aftermarket vehicle equipment.

There are no adjustments required at any time of the electrical components within the docking station. **Opening the docking station will void the product warranty.**

### During Installation:

**DO NOT** connect this docking station to the vehicle battery until:

1. All other electrical connections are made
2. Mounting of all components is complete
3. Verification that no shorts exist in the entire system

**DO NOT** install equipment or route wiring or cords in the deployment path of any air bag.

When drilling into the vehicle, DO make sure that both sides of the surface are clear of anything that could be damaged.

**CAUTION:** *If wiring is shorted to the frame, high current conductors can cause hazardous sparks resulting in electrical fires or flying molten metal.*

### After installation:

Test the docking station to ensure that it is working properly.

File these instructions in a safe place and refer to them when performing maintenance or re-installing.

**WARNING:** *Failure to follow all safety precautions and instructions may result in property damage, serious injury, or death.*

# FZ-G1 DOCKING STATION FEATURE IDENTIFICATION

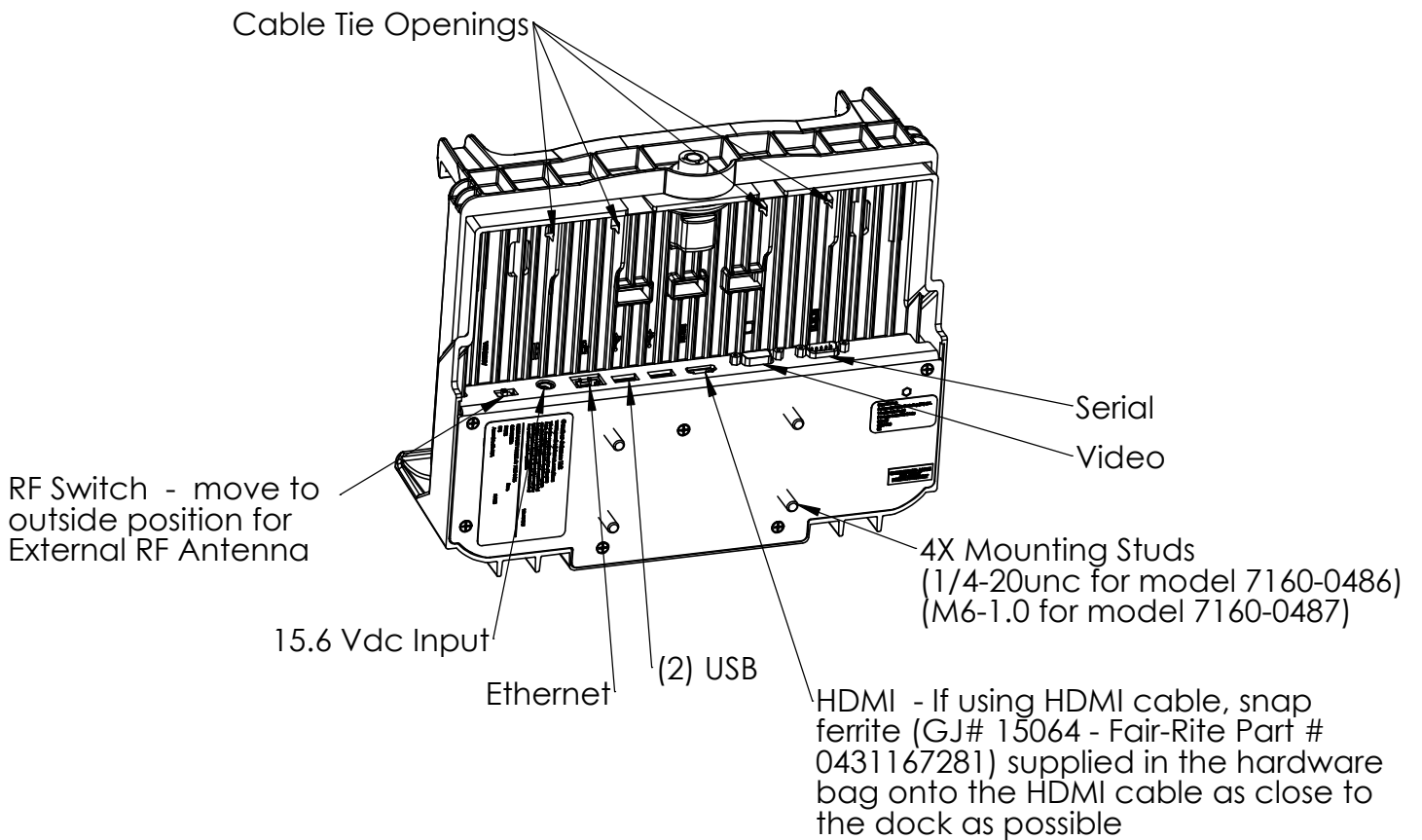
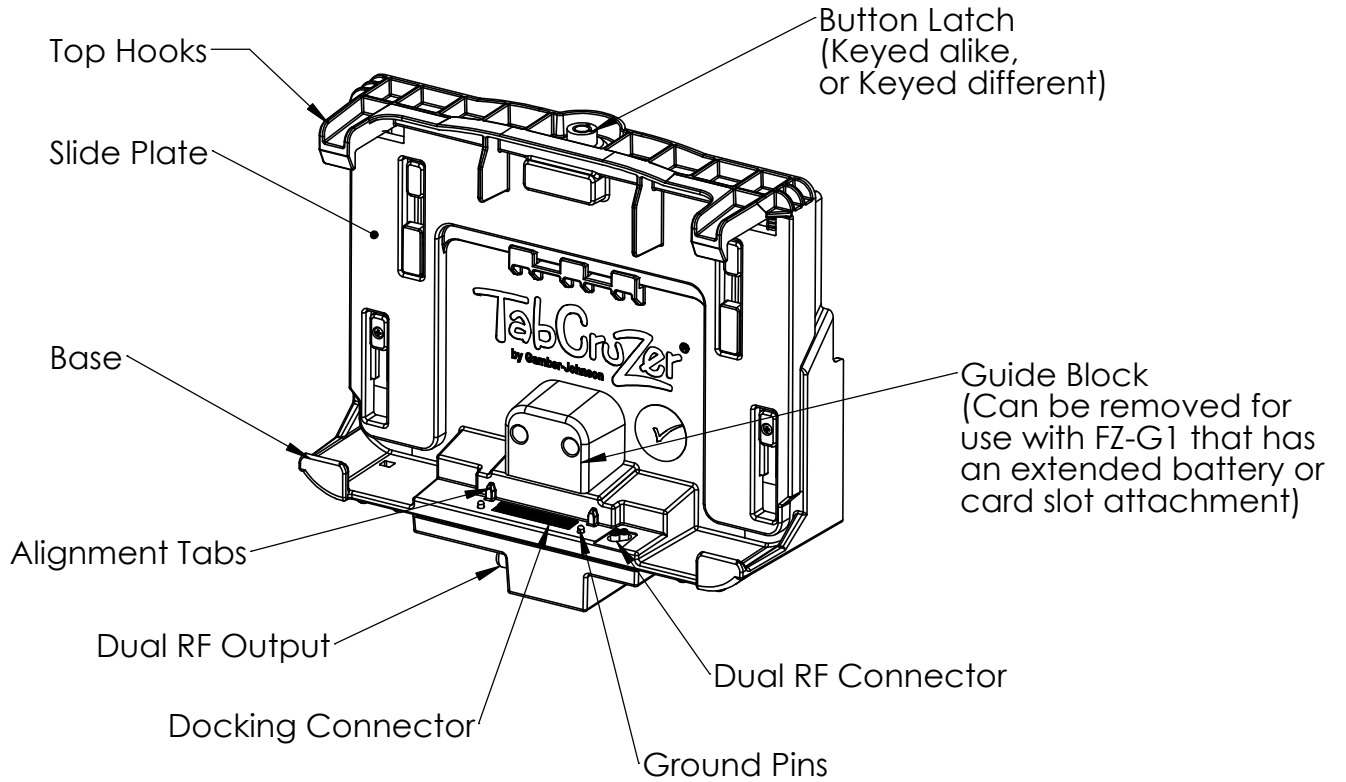

# DOCKING AND UNDOCKING THE COMPUTER

1. Turn the computer off.
2. With the slide plate in the open position, insert the bottom of the computer into the docking station. Make sure the guide tabs are lined up with the pockets on the back side of the computer.

Rotate the top of the computer under the top hooks until the computer is resting on the two vertical walls sticking out from the slide plate.  
(see Figures 1, 2 & 3)

**(Note: If your FZ-G1 computer has an extended battery or card slot attachment on the back side, you will need to remove the guide block from the face of the dock before inserting the computer.)**

3. Push downward on the slide plate to latch the dock. (See Figure 4)
4. (Optional) The key lock can now be used for security purposes.

## TO UNDOCK THE COMPUTER

1. Turn the computer off.
2. Unlock if locked.
3. Press the Latch Button. The slide plate is spring loaded and should raise with your hand when you release the button.
4. Rotate the top of the computer out of the dock to remove.

**Figure 1**

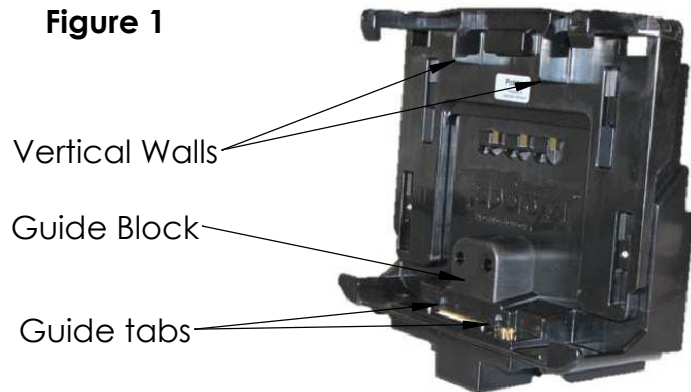

**Figure 2**



**Figure 3**



**Figure 4**



# Regulatory Certification Information

Regulatory Model #: 7160-0486

GJ Model #'s: 7160-0486-00, 7160-0486-02, 7160-0486-03, 7160-0486-04  
7160-0486-00-P, 7160-0486-02-P, 7160-0486-03-P, 7160-0486-04-P  
7160-0487-00, 7160-0487-02, 7160-0487-03, 7160-0487-04  
7160-0487-00-E, 7160-0487-02-E, 7160-0487-03-E, 7160-0487-04-E

Descriptions: Dock-Panasonic-FZG1

## Certifications:

- EN 55022:2010 CISPR 22:2008 Class B
- EN 50498:2010
- EN 50581:2012
- IEC 60950-1/A1:2009
- EN 60950-1/A12:2011
- CAN/CSA C22.2 No. 60950-1/A1:2011
- UL 60950-1/R:2011-12
- E-Mark

This device complies with Part 15 of the FCC Rules. Operation is subject to the following two conditions. (1) this device may not cause harmful interference, and (2) this device must accept any interference received, including interference that may cause undesired operation.

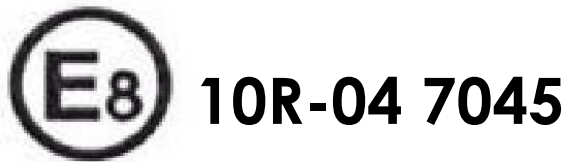

Gamber-Johnson LLC, 3001 Borham Ave.,  
Stevens Point, WI, 54481, USA, 715-344-3482