

GTX™ 330, GTX™ 330D TRANSPONDER INSTALLATION MANUAL



GARMIN International, Inc.
1200 E. 151st Street
Olathe, KS 66062 USA

190-00207-02 Revision 1
March 2002

© Copyright 2002
GARMIN Ltd. or its subsidiaries
All Rights Reserved

Except as expressly provided herein, no part of this manual may be reproduced, copied, transmitted, disseminated, downloaded or stored in any storage medium, for any purpose without the express prior written consent of GARMIN. GARMIN hereby grants permission to download a single copy of this manual and of any revision to this manual onto a hard drive or other electronic storage medium to be viewed and to print one copy of this manual or of any revision hereto, provided that such electronic or printed copy of this manual or revision must contain the complete text of this copyright notice and provided further that any unauthorized commercial distribution of this manual or any revision hereto is strictly prohibited.

Information in this document is subject to change without notice. GARMIN reserves the right to change or improve its products and to make changes in the content without obligation to notify any person or organization of such changes or improvements.

GARMIN International, Inc.
1200 E. 151st Street
Olathe, KS 66062 USA
Telephone: 913-397-8200
Dealer Line: 1-800-800-1420
Web Site Address: www.garmin.com

INFORMATION SUBJECT TO EXPORT CONTROL LAWS

This document may contain information which is subject to the Export Administration Regulations (“EAR”) issued by the United States Department of Commerce (15 CFR, Chapter VII, Subchapter C) and which may not be exported, released, or disclosed to foreign nationals inside or outside of the United States without first obtaining an export license. A violation of the EAR may be subject to a penalty of up to 10 years imprisonment and a fine of up to US\$1,000,000 under Section 2410 of the Export Administration Act of 1979. Include this notice with any reproduced portion of this document.

RECORD OF REVISIONS

Revision	Revision Date	Description	ECO #
1	03/22/00	Preliminary Release	-

TABLE OF CONTENTS

To be supplied

This page intentionally left blank

1. GENERAL DESCRIPTION

1.1 INTRODUCTION

This manual describes the physical, mechanical, and electrical characteristics and the installation requirements for the GTX 330 Mode S Transponder and GTX 330D Diversity Mode S Transponder. In this manual, the term GTX 330 applies to both transponders unless otherwise stated. Information pertaining to the maintenance, alignment, and procurement of replacement parts is found in the GTX 330 Maintenance Manual, P/N 190-00207-05. After installation of the GTX 330, FAA Form 337 must be completed by an appropriately certificated agency to return the aircraft to service.

1.2 EQUIPMENT DESCRIPTION

The Garmin GTX 330 is a panel mounted Mode S Transponder with the addition of timers, altitude reporting, mode S interrogation and reply, and multiple transmit/receive ARINC 429 and RS232 data ports. The Mode S transponder has the capability to transmit a unique address for every aircraft.

The GTX 330 is a radio transmitter and receiver that operates on radar frequencies, receiving ground radar or TCAS interrogations at 1030 MHz and transmitting a coded response of pulses to ground-based radar on a frequency of 1090 MHz. The GTX 330 is equipped with IDENT capability that activates the Special Position Identification (SPI) pulse for 18 seconds.

As with other Mode A/Mode C transponders, the GTX 330 replies with any one of 4,096 codes, which differ in the position and number of pulses transmitted. By replying to ground transmissions or TCAS interrogations, the GTX 330 enables ATC to display aircraft identification, altitude and ground speed as well as identification numbers on ATC radar screens or TCAS traffic indicators.

The GTX 330 is configured with all key controls. The layout of the front panel keys and displays segregates the transponder's primary functions from the secondary functions. The unit can be configured so the aircraft avionics master bus can turn the unit on.

1.3 INTERFACE SUMMARY

The GTX 330 provides the following interface connections via the rear connector:

- Ten (10) encoding altimeter inputs.
- External IDENT input.
- External STBY input.
- External suppression pulse input.
- Switched power output of up to 1.5 amps (for digital altitude encoder power).
- Aircraft power input (11 to 33 volts).
- Aircraft dimming buss input voltage.
- Aircraft master switch turn-on option.

- Serial altitude or GPS groundspeed input.
- Serial altitude output.
- Mode S with Extended Squitter, Comm A and Comm B protocol.
- Temperature, Altitude Hold, Density Altitude and the ability to enter flight ID or tail numbers.
- Digitally recorded voice and discrete warning annunciator activated by Altitude Hold when limits are exceeded.
- Diversity: GTX 330 is available with or without the Diversity feature.

1.4 GTX 330 TECHNICAL SPECIFICATIONS

1.4.1 GTX 330 Electrical Specifications

SPECIFICATION	CHARACTERISTIC
TSO, JTSO; GTX 330	TSO-C112 CL _{2A4} 121 010, JTSO-2C112a.
TSO, JTSO; GTX 330D	TSO-C112 CL _{2A4} 121 011, JTSO-2C112a.
TSO ENV CAT	Refer to appendix A
Applicable Documents	RTCA DO-160D, DO-181C
Temperature Range	-45°C to +55°C (Continuous Operation)
Power Requirements	11.0 to 33.0 Vdc; Power Input: 22 Watts typical, 45 Watts Maximum
Humidity	95% @ +55°C for 16 Hours; 85% @ +38°C for 32 Hours
Altitude	55,000 Feet
Transmitter Frequency	1090 MHz
Transmitter Power	125 Watts minimum, 250 Watts nominal.
Receiver Frequency	1030 MHz
Receiver Sensitivity	-74 dBm Nominal for 90% replies
Mode A Capability	4096 Identification Codes
Mode C Capability	100 Foot Increments from -1000 to 62,700 feet. 25 Foot Increments with suitable serial data link.
Mode S Capability	Aircraft Identification, Altitude and Ground Speed
External Suppression Input	Low ≤ 0.5 V; High ≥ 8 V

1.4.2 Physical Characteristics of the GTX 330

SPECIFICATION	CHARACTERISTIC
Bezel Height	1.65 inches (42 mm)
Bezel Width	6.25 inches (159 mm)
Rack Height (Dimple to Dimple)	1.68 inches (43 mm)
Rack Width	6.30 inches (160 mm)
Depth Behind Panel with Connectors (measured from face of aircraft panel to rear of connector backshells)	11.25 inches (286 mm)
GTX 330 Unit Weight	3.4 lbs. (1.5 kg)
GTX 330 Rack Weight (Installed with rack and connectors)	4.2 lbs. (1.9 kg)

1.4.3 GTX 330 Configurations Available

GARMIN P/N	GTX 330 Description
010-00230-00	Black Front Panel
010-00230-20	Gray Front Panel
010-00230-10	Black Front Panel, Diversity
010-00230-30	Gray Front Panel, Diversity

1.4.4 Equipment Available

ITEM	GARMIN P/N
Sub Assy, Connector Kit, GTX 330	011-00583-00
SMP, Install Rack, GTX 330	115-00294-00
Sub Assy, Backplate, GTX 330	011-00582-00 (For use with GTX 330)
Sub Assy, Backplate, GTX 330D	011-00582-01 (For use with GTX 330D)
GARMIN GTX 330 Antenna kit	010-10160-00

1.4.5 Additional Equipment Required

- Antenna Sealant - Use antenna manufacturer's instructions, install according to FAA AC 43.13-2A.
- Cables - The installer will supply all system cables including circuit breakers. Cable requirements and fabrication is detailed in Section 2 of this manual.
- Hardware - #6 Flat Head Screw (6 ea.) and #6-32 Self-Locking Nut (6 ea.). Hardware required to mount installation rack is not provided.
- Encoding Altitude Digitizer - Use encoding altimeter manufacturer's instructions, install according to FAA AC 43.13-2A.

1.5 INSTALLATION APPROVAL

The conditions and tests required for TSO approval of the GTX 330 Transponder and antenna are minimum performance standards. It is the responsibility of those desiring to install this transponder and antenna either on or within a specific type or class of aircraft to determine that the aircraft installation standards are within the TSO standards. For GTX 330 TSO compliance, see Appendix A. For antenna TSO compliance, refer to antenna manufacturer's literature.

1.6 AIRCRAFT STATION LICENSING REQUIREMENTS

The Telecommunications Act of 1996, effective February 8, 1996, provides the FCC discretion to eliminate radio station license requirements for aircraft and ships. The GTX 330 installation must comply with current transmitter licensing requirements. To find out the specific details on whether a particular installation is exempt from licensing, please see FCC Fact Sheet PR 5000 or contact the FCC at (800)-322-1117.

If an aircraft license is required, make application for a license on FCC form 404, Application for Aircraft Radio Station License. The FCC also has a fax-on-demand service to provide forms by fax at (202)-418-0177.

The GTX 330 owner accepts all responsibility for obtaining the proper licensing before using the transponder.

1.7 LIMITED WARRANTY

GARMIN warrants this product to be free from defects in materials and manufacture for one year from the date of purchase. GARMIN will, at its sole option, repair or replace any components that fail in normal use. Such repairs or replacement will be made at no charge to the customer for parts or labor. The customer is, however, responsible for any transportation costs. This warranty does not cover failures due to abuse, misuse, accident or unauthorized alteration or repairs.

THE WARRANTIES AND REMEDIES CONTAINED HEREIN ARE EXCLUSIVE AND IN LIEU OF ALL OTHER WARRANTIES EXPRESS OR IMPLIED OR STATUTORY, INCLUDING ANY LIABILITY ARISING UNDER ANY WARRANTY OF MERCHANTABILITY OR FITNESS FOR A PARTICULAR PURPOSE, STATUTORY OR OTHERWISE. THIS WARRANTY GIVES YOU SPECIFIC LEGAL RIGHTS, WHICH MAY VARY FROM STATE TO STATE.

IN NO EVENT SHALL GARMIN BE LIABLE FOR ANY INCIDENTAL, SPECIAL, INDIRECT OR CONSEQUENTIAL DAMAGES, WHETHER RESULTING FROM THE USE, MISUSE, OR INABILITY TO USE THIS PRODUCT OR FROM DEFECTS IN THE PRODUCT. SOME STATES DO NOT ALLOW THE EXCLUSION OF INCIDENTAL OR CONSEQUENTIAL DAMAGES, SO THE ABOVE LIMITATIONS MAY NOT APPLY TO YOU.

To obtain warranty service, call the GARMIN Customer Service department (913-397-8200) for a returned merchandise tracking number. The unit should be securely packaged with the tracking number clearly marked on the outside of the package and sent freight prepaid and insured to a GARMIN warranty service station. A copy of the original sales receipt is required as the proof of purchase for warranty repairs. GARMIN retains the exclusive right to repair or replace the unit or offer a full refund of the purchase price at its sole discretion. SUCH REMEDY SHALL BE YOUR SOLE AND EXCLUSIVE REMEDY FOR ANY BREACH OF WARRANTY.

This page intentionally left blank

2. INSTALLATION

2.1 INTRODUCTION

This section provides the necessary information for installing the GTX 330 Mode S Transponder, and where required, optional accessories. Installation of the GTX 330 will differ according to equipment location and other factors. Cabling will be fabricated by the installing agency to fit these various requirements. Appendix B contains interconnect wiring diagrams, mounting dimensions, and information pertaining to installation. Each installation shall be accomplished to meet the requirements of FAA AC 43.13-2A.

2.2 UNPACKING AND INSPECTING EQUIPMENT

Carefully unpack the equipment and make a visual inspection of the unit for evidence of damage incurred during shipment. If the unit is damaged, notify the carrier and file a claim. To justify a claim, save the original shipping container and all packing materials. Do not return the unit to GARMIN until the carrier has authorized the claim.

Retain the original shipping containers for storage. If the original containers are not available, a separate cardboard container should be prepared that is large enough to accommodate sufficient packing material to prevent movement.

2.3 ANTENNA INSTALLATION

2.3.1 Location Considerations

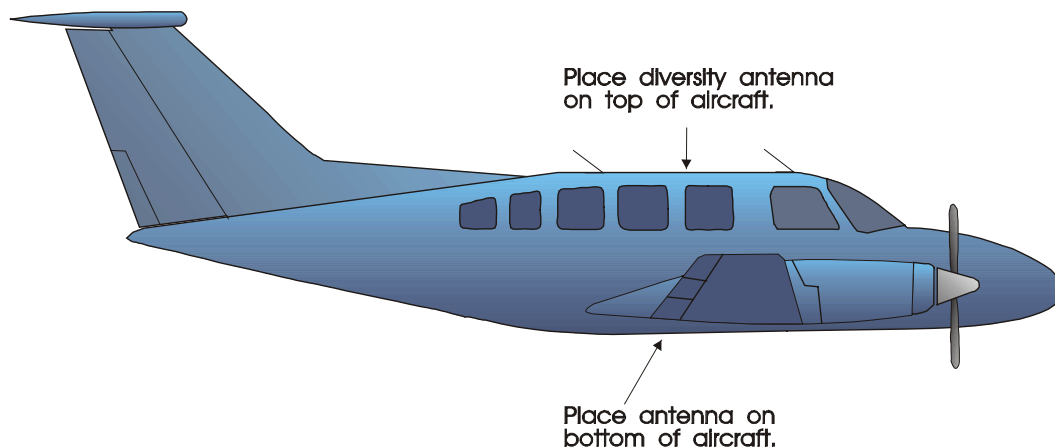

Figure 2-1. Antenna Installation Considerations

- A. The antenna (GARMIN P/N 010-10160-00) should be mounted away from major protrusions, such as engine(s), propeller(s), and antenna masts. It should also be as far as practical from landing gear doors, access doors, or other openings that could effect its radiation pattern.
- B. The antenna should be mounted on the underside of the aircraft and in a vertical position when the aircraft is in level flight. The diversity antenna should be mounted on the top of the aircraft.
- C. Avoid mounting the antenna within three feet of the ADF sense antenna or any other communication antenna and six feet from the DME antenna.
- D. To prevent RF interference, the antenna must be physically mounted a minimum distance of three feet from the GTX 330.

NOTE

If the antenna is being installed on a composite aircraft, ground planes must sometimes be added. Conductive wire mesh, radials, or thin aluminum sheets embedded in the composite material provide the proper ground plane allowing the antenna pattern (gain) to be maximized for optimum transponder performance.

2.3.2 Antenna Installation

Install the antenna according to the antenna manufacturer's instructions and FAA AC 43.13-2A.

2.3.3 Installation Approval Considerations for Pressurized Aircraft

Antenna and cable installations on pressurized cabin aircraft require FAA approved installation design and engineering substantiation data whenever such installations incorporate alteration (penetration) of the cabin pressure vessel by connector holes and/or mounting arrangements.

For needed engineering support pertaining to the design and approval of such pressurized aircraft antenna installations, it is recommended that the installer proceed according to any of the following listed alternatives:

1. Obtain approved antenna installation design data from the aircraft manufacturer.
2. Obtain an FAA approved Supplemental Type Certificate (STC) pertaining to and valid for the subject antenna installation.
3. Contact the FAA Aircraft Certification Office in the appropriate Region and request identification of FAA Designated Engineering Representatives (DERs) who are authorized to prepare and approve the required antenna installation engineering data.
4. Obtain FAA Advisory Circular AC-183C and select (and contact) a DER from the roster of individuals identified thereunder.
5. Contact an aviation industry organization such as the Aircraft Electronics Association and request their assistance.

2.3.4 Antenna Cable Installation

When routing antenna cables, observe the following precautions:

- All cable routing should be kept as short as possible and as direct as possible.
- Avoid sharp bends.
- Avoid routing cables near power sources (e.g., 400 Hz generators, trim motors, etc.) or near power for fluorescent lighting.
- Avoid routing cable near ADF antenna cable (allow at least a 12-inch separation).

The following table lists examples of the recommended antenna cable vendors and the type of cable to be used for specific lengths of cable. Any cable meeting specifications is acceptable for the installation. The maximum coaxial cable attenuation at 1090 MHz must not exceed 1.5 dB.

Max. Length (feet)	ECS Type	MIL-C-17 Type	RG Type
8.8		M17/128	RG400
10.0	3C142B		
12.5		M17/112	RG304
17.0	311601	M17/127	RG393
21.0	311501		
27.0	311201		
41.0	310801		
Supplier Information	Vendor: Electronic Cable Specialists 5300 W. Franklin Drive Franklin, WI 53132 Tel: 800-327-9473 414-421-5300 Fax: 414-421-5301	MIL-C-17 types: See current issue of Qualified Products List QPL-17.	RG types: See current issue of Qualified Products List QPL-17.

2.4 COOLING AIR

The GTX 330 meets all TSO requirements without forced air-cooling. (The application of forced air cooling to the rear air nozzle of the GTX 330 provides beneficial cooling to the unit. The GTX 330 is designed to dissipate its internal heat without the need of blowing air inside the unit.)

The GTX 330 was designed to handle a constant 450 PRF, with short periods of 1200 PRF. Rate limit is set at 1200 PRF. A typical radar site would interrogate the transponder once every 5 to 10 seconds for approximately 100 msec at a 400 PRF rate. In very high traffic areas with multiple ground stations and TCAS traffic it is possible to have long term PRF rates above 450 PRF. The GTX 330 measures the unit temperature and without forced air-cooling the reply rate will be reduced to protect the transmitter from overheating.

2.5 GTX 330 INSTALLATION

NOTE

Avoid installing the unit near heat sources. If this is not possible, insure that additional cooling is provided. Allow adequate space for installation of cables and connectors. The installer will supply and fabricate all of the cables. All wiring must be in accordance with FAA AC 43.13-2A.



Figure 2-2 Unit Installation Considerations

1. Assemble the connector/rack kit according to figure 4-2. Install the rack assembly according to the dimensions given in figures 4-1 and paragraph 1.4.2 Physical Characteristics of the GTX 330. Mounting brackets are not supplied due to the wide range of mounting configurations available. Suitable mounting brackets may be fabricated from sheet metal or angle stock. To insure a sturdy mount, rear support for the unit must be provided.
2. Looking at the bottom of the transponder, make sure the front lobe of the locking mechanism is in a vertical position. This can be accomplished by using a 3/32" Allen wrench through the face plate.
3. Slide the unit into the rack until the front lobe of the unit touches the rack.
4. Turn the Allen wrench clockwise until unit is secured in the rack. Continue turning until tight. Do not overtighten the screw.
5. To remove the unit from the rack, turn the 3/32" Allen wrench counterclockwise until it disengages from the rack.

3. INSTALLATION PROCEDURE

3.1 ANTENNA INSTALLATION

3.1.1 Antenna Installation

Install the antenna according to the antenna manufacturer's instructions and FAA AC 43.13-2A.

3.1.2 Antenna Cable Connectors

The antenna cable requires a BNC connector at the antenna and a male BNC "Blindmate" connector (P/N 330-00053-01, supplied with GTX 330 backplate assembly, 011-00582-00/01 at the transponder. Follow BNC connector manufacturer instructions for assembly of the BNC connector.

3.2 ELECTRICAL CONNECTIONS

All electrical connections, except for the antenna, are made through a single, 62 pin D-subminiature connector. Figure 2-1 defines the electrical characteristics of all input and output signals and identifies the cable requirements for each signal. Required connector and associated hardware are supplied in the connector kit (P/N 011-00583-00). See figures 4-1 and 4-2 for interconnect wiring diagrams.

CAUTION

Check wiring connections for errors before inserting the GTX 330 into the rack. Incorrect wiring could cause internal component damage.

Pin Contact Part Numbers

	62 pin connector (P3301)
Wire Gauge	22-28 AWG
GARMIN P/N	336-00021-00
Military P/N	M39029/58-360

Recommended Crimp Tools

Wire Gauge	20-24 AWG		
	Hand Crimping Tool	Positioner	Insertion/ Extraction Tool
Military P/N	M22520/2-01	M22520/2-08	M81969/1-02
Positronic	9507	9502-5	M81969/1-02
ITT Cannon	995-0001-584	995-0001-604	980-2000-426
AMP	601966-1	601966-5	91067-2
Daniels	AFM8	K13-1	M24308/1-02
Astro	615717	615724	M81969/1-02

NOTES

1. Insertion/extraction tools from ITT Cannon are all plastic; others are plastic with metal tip.
2. Non-GARMIN part numbers shown are not maintained by GARMIN and consequently are subject to change without notice.
3. All wires must be passed through the backshell before being assembled to connector.

3.4 POST INSTALLATION CHECKOUT

<i>CAUTION</i>

Be sure to check all aircraft control movements before flight is attempted to insure that the wiring harness does not touch any moving part.

Verify proper operation of the transponder during a flight test under VFR conditions.

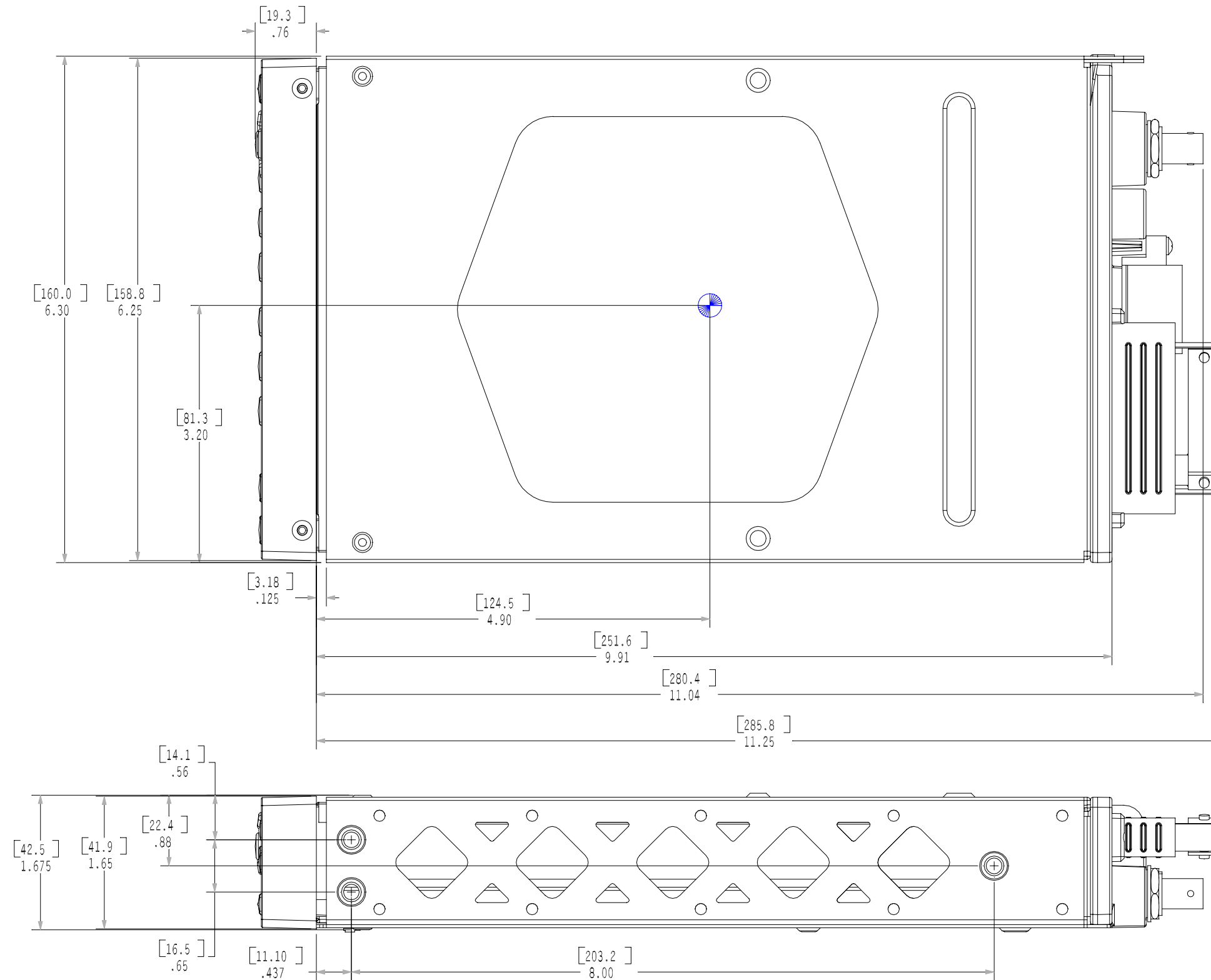

Figure 3-1 GTX 330 OUTLINE DRAWING

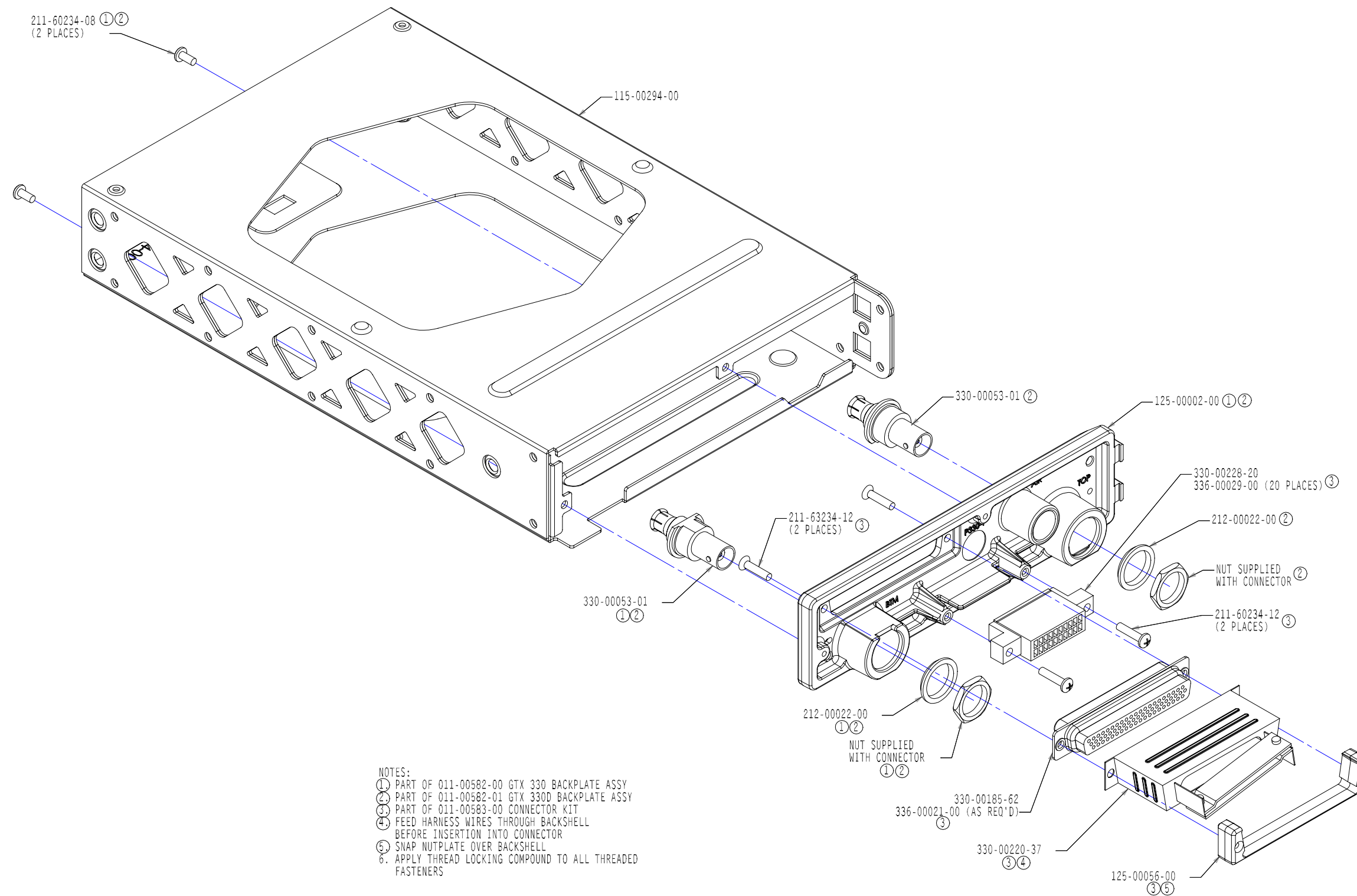
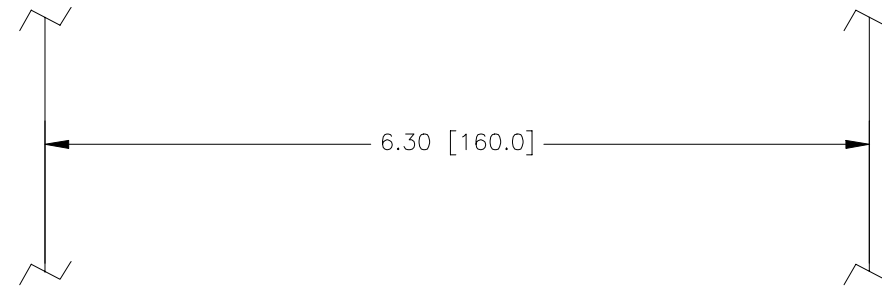

Figure 3-2 GTX 330 CONNECTOR/RACK ASSEMBLY DRAWING

GTX 330 (115-00294-00)

OPTION 1:

STACK CUTOUT (RACK INSTALLED FROM FRONT OF AIRCRAFT PANEL)



OPTION 2:

RADIO CUTOUT (RACK INSTALLED FROM FRONT OF AIRCRAFT PANEL)

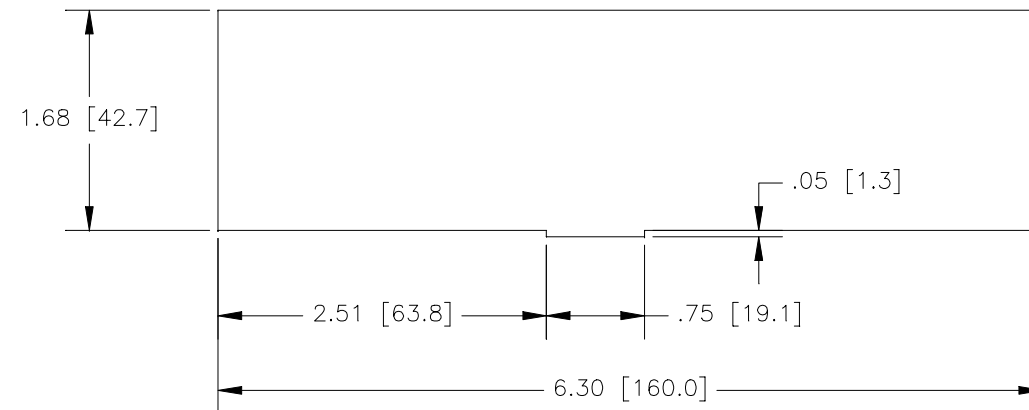

OPTION 3:

RADIO CUTOUT (RACK INSTALLED FROM BACK OF AIRCRAFT PANEL ONLY)
MAXIMUM AIRCRAFT PANEL THICKNESS IS .125 INCH [3.2 mm]

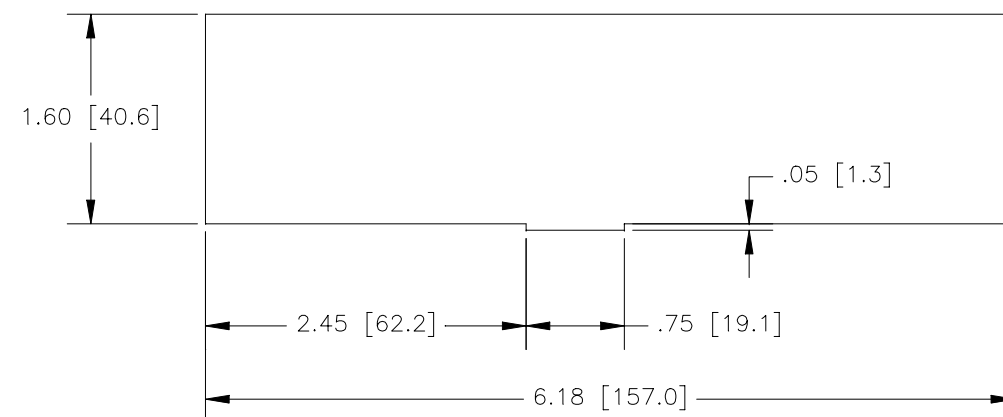

NOTES:

1. DIMENSIONS: INCH [mm].
2. IF THE FRONT LIP OF THE MOUNTING RACK IS BEHIND THE SURFACE OF THE AIRCRAFT PANEL, THE UNIT CONNECTORS MAY NOT FULLY ENGAGE.

Figure 3-3 GTX 330 RECOMMENDED PANEL CUTOUT DIMENSIONS

4. SYSTEM INTERCONNECTS

4.1 PIN FUNCTION LIST

4.1.1 J3301

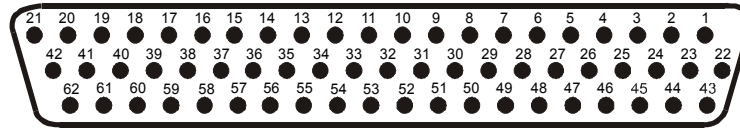

Figure 4-1. Rear Connector, J3301

Connector P3301		
Pin	Pin Name	I/O
1	AVIONICS MASTER ON SELECT*	In
2	ALTITUDE A1	In
3	ALTITUDE C2	In
4	ALTITUDE A2	In
5	ALTITUDE A4	In
6	ALTITUDE C4	In
7	ALTITUDE B1	In
8	ALTITUDE C1	In
9	ALTITUDE B2	In
10	ALTITUDE B4	In
11	ALTITUDE D4	In
12	EXTERNAL IDENT SELECT*	In
13	EXTERNAL STANDBY SELECT*	In
14	28 V LIGHTING BUS HI	In
15	AUDIO OUT HI	Out
16	AUDIO OUT LO	Out
17	SQUAT SWITCH IN	In
18	RESERVED	--
19	ALTITUDE ALERT ANNUNCIATE*	Out
20	RESERVED	--
21	AIRCRAFT POWER	In
22	RS 232 IN 1	In
23	RS 232 OUT 1	Out
24	RS 232 IN 2	In
25	RS 232 OUT 2	Out
26	ARINC 429 IN 3 A	In
27	AIRCRAFT GROUND	--
28	ARINC 429 OUT 2 B	Out
29	ARINC 429 IN 3 B	In
30	ARINC 429 OUT 2 A	Out
31	EXTERNAL SUPPRESSION I/O	I/O
32	ARINC 429 IN 1 A	In
33	ARINC 429 IN 2 A	In

Table 4-1. P3301 Pin Assignments

Connector P3301, continued		
Pin	Pin Name	I/O
34	ARINC 429 OUT 1 B	Out
35	ARINC 429 IN 1 B	In
36	ARINC 429 IN 2 B	In
37	ARINC 429 OUT 1 A	Out
38	TEMPERATURE PROBE 1 OUT	Out
39	TEMPERATURE PROBE 1 IN	In
40	RESERVED	--
41	TEMPERATURE PROBE 2 OUT	Out
42	AIRCRAFT POWER	In
43	AIRCRAFT GROUND	--
44	TEMPERATURE PROBE 2 IN	In
45	14 V/5 V LIGHTING BUS HI	In
46	TIS CONNECT SELECT*	In
47	RESERVED	--
48	ARINC 429 IN 4 A	In
49	ARINC 429 IN 4 B	In
50	ALTITUDE COMMON (GROUND)	In
51	RESERVED	--
52	RESERVED	--
53	RESERVED	--
54	RESERVED	--
55	RESERVED	--
56	RESERVED	--
57	RESERVED	--
58	RESERVED	--
59	RESERVED	--
60	RESERVED	--
61	RESERVED	--
62	SWITCHED POWER OUT	Out

Table 4-1. P3301 Pin Assignments (Cont'd)

* Ground to activate.

Refer to Figure 4-1 on page 4-5 for GTX 330 interconnect wiring diagram.

4.2 Power and Lighting Function

Power Input requirements and Lighting Bus input are listed in the following tables. The power-input pins accept 11-33 VDC. Switched Power Out is a power source available for devices such as a remote digital altitude encoder.

4.2.1 Aircraft Power

PIN NAME	CONNECTOR/PIN	I/O
AIRCRAFT POWER	P3301 21	In
AIRCRAFT POWER	P3301 42	In
SWITCHED POWER OUT	P3301 62	Out
AIRCRAFT GROUND	P3301 27	--
AIRCRAFT GROUND	P3301 43	--

Table 4-2. Aircraft Power Pin Assignments

4.2.2 Lighting Bus

The GTX 330 unit can be configured to track a 28 VDC, 14 VDC, 5 VDC or 5 VAC lighting bus using these inputs. The GTX 330 can also automatically adjust for ambient lighting conditions based on the photocell. Refer to sections 5.2.5. and 5.2.6.

PIN NAME	CONNECTOR/PIN	I/O
14 V/5 V LIGHTING BUS HI	P3301 45	In
28 V LIGHTING BUS HI	P3301 14	In

Table 4-3. Aircraft lighting Pin Assignments

4.3 Temperature Inputs

Pin Name	Connector	Pin	I/O
TEMPERATURE PROBE 1 OUT	P3301	38	Out
TEMPERATURE PROBE 1 IN	P3301	39	In
TEMPERATURE PROBE 2 OUT	P3301	41	Out
TEMPERATURE PROBE 2 IN	P3301	44	In

Table 4-4. Temperature Probe Pin Assignments

Temperature is used for Density Altitude computations. Probe #1 is for a voltage mode sensor. Probe #2 is for a current mode sensor. Refer to section 5.2.11.

4.4 Altitude Function

Altitude inputs are considered active if either the voltage to ground is $< 1.9\text{ V}$ or the resistance to ground is $< 375\ \Omega$. These inputs are considered inactive if the voltage to ground is 11-33 VDC.

NOTE

The GTX 330 contains internal altitude code line isolation diodes to prevent the unit from pulling the encoder lines to ground when the transponder is turned off.

Pin Name	CONNECTOR/PIN	I/O
ALTITUDE D4	P3301 11	In
ALTITUDE A1	P3301 2	In
ALTITUDE A2	P3301 4	In
ALTITUDE A4	P3301 5	In
ALTITUDE B1	P3301 7	In
ALTITUDE B2	P3301 9	In
ALTITUDE B4	P3301 10	In
ALTITUDE C1	P3301 8	In
ALTITUDE C2	P3301 3	In
ALTITUDE C4	P3301 6	In
ALTITUDE COMMON	P3301 50	--

Table 4-5. Encoded Altitude Pin Assignments

4.4.1 Altimeter Calibration and Checkout

Refer to section 5.2.13 for the gray code altitude checkout.

4.4.2 Altimeter Interconnect, Dual GTX 330 Units

Refer to Figure 4-2 on page 4-7 for Dual GTX 330 altimeter interconnect.

4.5 Discrete Inputs

Pin Name	Connector	Pin	I/O
EXTERNAL IDENT SELECT	P3301	12	In
EXTERNAL STANDBY SELECT*	P3301	13	In
SQUAT SWITCH IN	P3301	17	In
ALTITUDE ALERT ANNUNCIATE*	P3301	19	Out
TIS CONNECT SELECT*	P3301	46	In

Table 4-6. Discrete Inputs Pin Assignments

These inputs are considered active if either the voltage to ground is $< 1.9\text{ V}$ or the resistance to ground is $< 375\ \Omega$. These inputs are considered inactive if the voltage to ground is 11-33 VDC.

EXTERNAL IDENT SELECT (remote IDENT) is a momentary input. Refer to sections 5.2.10. and 5.2.14 for the squat switch.

4.6 Serial Data Electrical Characteristics

Pin Name	Connector	Pin	I/O
RS 232 OUT 1	P3301	23	Out
RS 232 IN 1	P3301	22	In
RS 232 OUT 2	P3301	23	Out
RS 232 IN 2	P3301	24	In

Table 4-7. RS 232 Pin Assignments

The RS-232 outputs conform to EIA Standard RS-232C with an output voltage swing of at least ± 5 V when driving a standard RS-232 load. Refer to Figure 4-2 on page 4-7 for the RS-232 serial data interconnect. Refer to sections 5.2.9. and 5.2.16.

Pin Name	Connector	Pin	I/O
ARINC 429 OUT 1A	P3301	37	Out
ARINC 429 OUT 1B	P3301	34	Out
ARINC 429 IN 1A	P3301	32	In
ARINC 429 IN 1B	P3301	35	In
ARINC 429 IN 2A	P3301	33	In
ARINC 429 IN 2B	P3301	36	In
ARINC 429 OUT 2A	P3301	30	Out
ARINC 429 OUT 2B	P3301	28	Out
ARINC 429 IN 3A	P3301	26	In
ARINC 429 IN 3B	P3301	29	In
ARINC 429 IN 4A	P3301	48	In
ARINC 429 IN 4B	P3301	49	In

Table 4-8. ARINC 429 Pin Assignments

The ARINC 429 outputs conform to ARINC 429 electrical specifications when loaded with up to 5 standard ARINC 429 receivers. Refer to sections 5.2.8. and 5.2.17.

This page intentionally left blank

PRELIMINARY GTX 330 TYPICAL INTERCONNECT

JWD, 02/11/2002

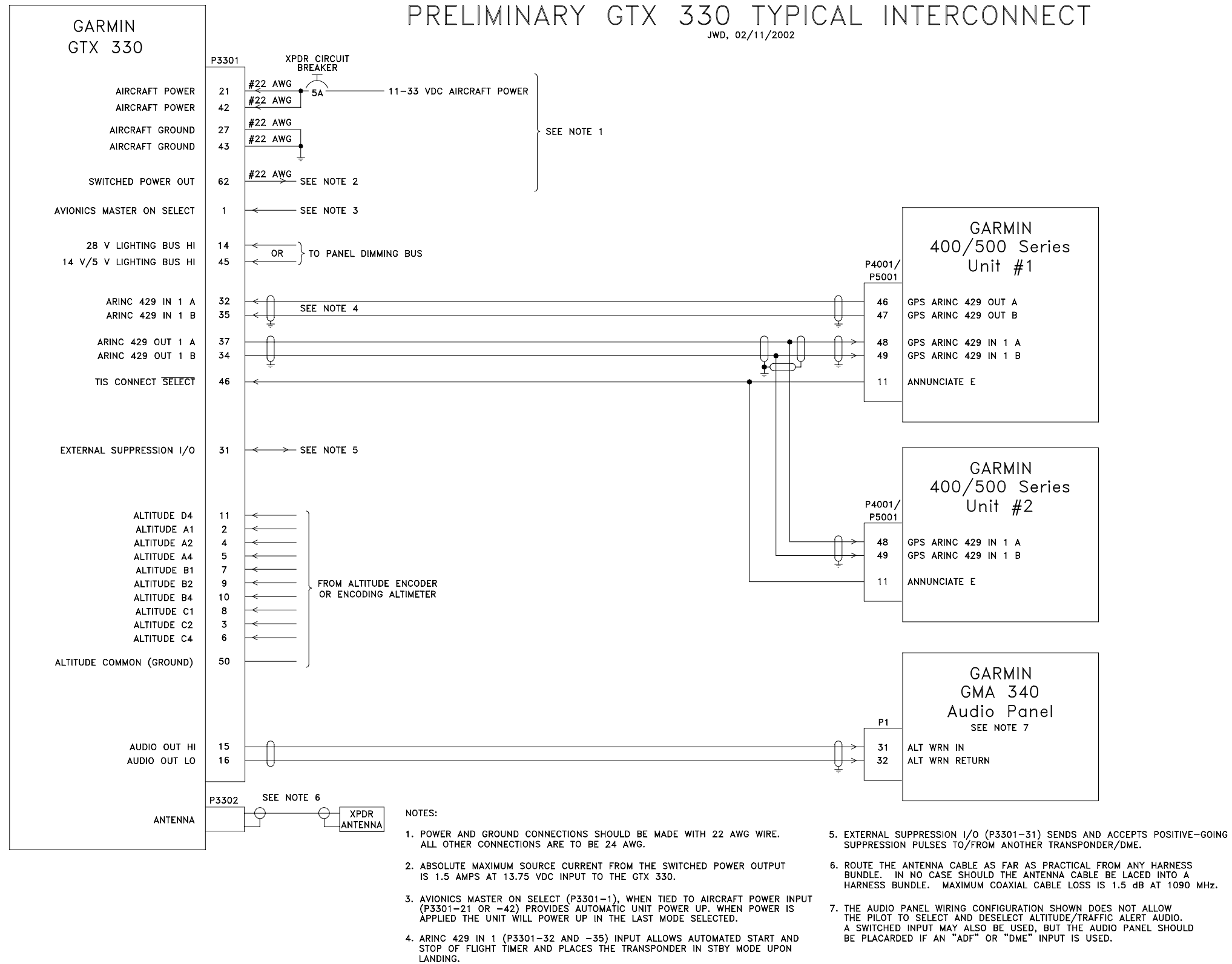
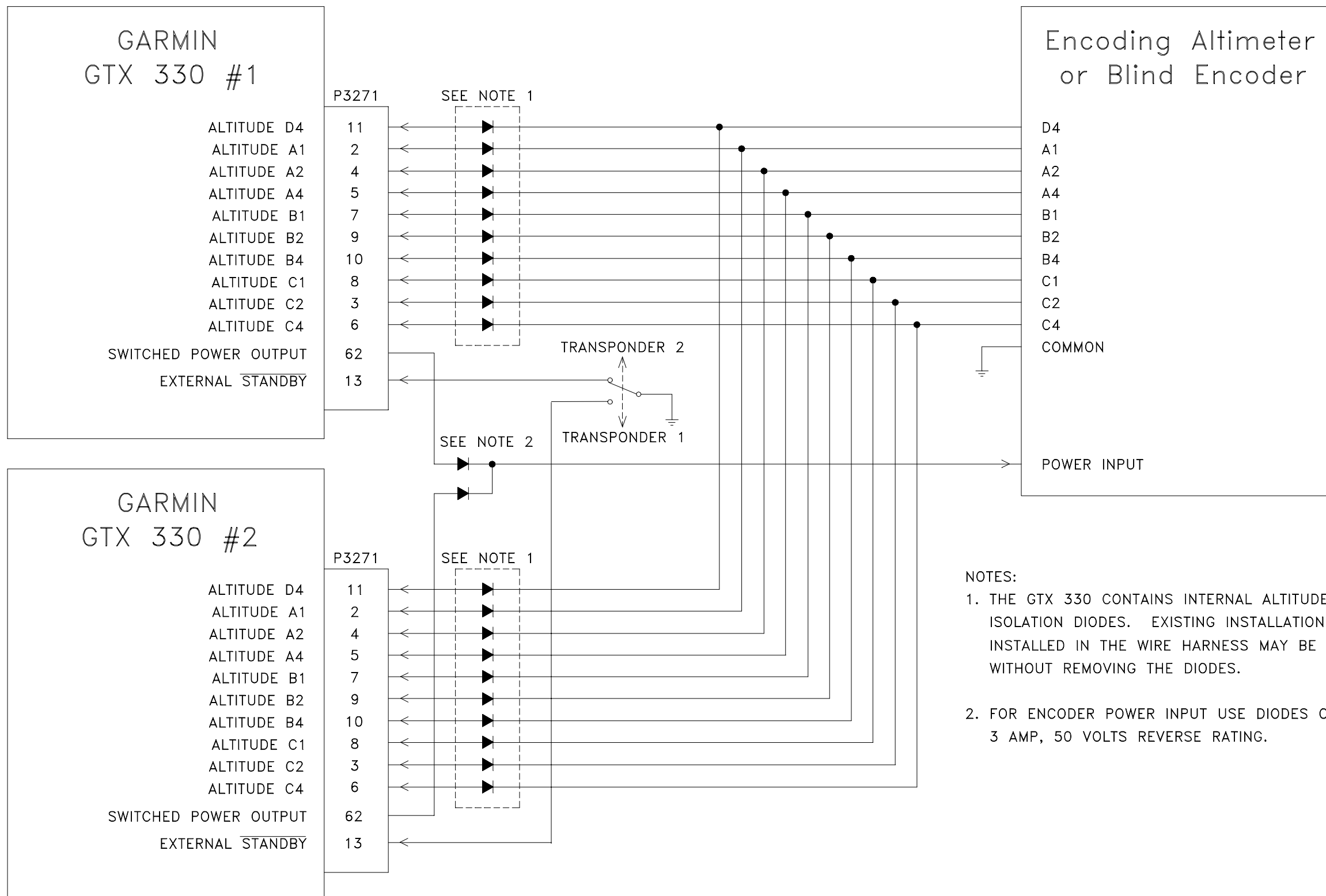

Figure 4-1 GTX 330 INTERCONNECT WIRING DIAGRAM



- NOTES:
1. THE GTX 330 CONTAINS INTERNAL ALTITUDE CODE LINE ISOLATION DIODES. EXISTING INSTALLATIONS WITH DIODES INSTALLED IN THE WIRE HARNESS MAY BE USED "AS IS" WITHOUT REMOVING THE DIODES.
 2. FOR ENCODER POWER INPUT USE DIODES OF AT LEAST 3 AMP, 50 VOLTS REVERSE RATING.

Figure 4-2 DUAL TXP INTERCONNECT WIRING DIAGRAM, ENCODING ALTITUDE CONNECTIONS

5. POST INSTALLATION CONFIGURATION AND CHECKOUT PROCEDURE

5.1 OPERATION

NOTE

The coverage you can expect from the GTX 330 is limited to line of sight. Low altitude or antenna shielding by the aircraft itself may result in reduced range. Range can be improved by climbing to a higher altitude. It may be possible to minimize antenna shielding by locating the antenna where dead spots are only noticed during abnormal flight attitudes.



Figure 5-1. GTX 330 Front Panel

NOTE

The GTX 330 should be turned off before starting aircraft engine(s).

5.1.1 Function Selector Switches

The function selection switches are:

- **OFF** — Powers off the GTX 330. Pressing the STBY, ON or ALT key powers on the transponder displaying the last active identification code.
- **STBY** — Selects the standby mode. When in standby mode, the transponder will not reply to any interrogations.
- **ON** — Selects Mode A and Mode S. In this mode, the transponder replies to Mode A, Mode C and Mode S interrogations, as indicated by the Reply Symbol (“**R**”), but the replies do not include altitude information.
- **ALT** — Selects Mode A, Mode C and Mode S. In ALT mode, the transponder replies to identification, altitude and Mode S interrogations as indicated by the Reply Symbol (“**R**”). Replies to altitude interrogations include the standard pressure altitude received from an external altitude source, which is not adjusted for barometric pressure. The ALT mode may be selected in aircraft not equipped with an optional altitude encoder; however, the reply signal will not include altitude information.

NOTE

Any time the function switch is in the ON or ALT position the transponder becomes an active part of the Air Traffic Control Radar Beacon System (ATCRBS). The transponder also responds to interrogations from TCAS equipped aircraft.

- IDENT — Pressing the IDENT key activates the Special Position Identification (SPI) Pulse for 18 seconds, identifying the transponder return from others on an air traffic controller's screen. During the IDENT period the word 'IDENT' appears in the upper left corner of the display.
- VFR — Sets the transponder code to the pre-programmed VFR code selected in Configuration Mode (Set to 1200 at the factory). Pressing the VFR key again will restore the previous identification code.
- FUNC — Changes the page shown on the right side of the display. Display data includes Pressure Altitude, Flight Time, Count Up and Count Down timers. In the Configuration Mode, steps through the function pages.
- START/ STOP — Starts and stops the Count Up, Count Down and Flight timers. In configuration mode, steps through functions in reverse.
- CRSR — Initiates entry of the starting time for the Count Down timer and cancels transponder code entry. Selects changeable fields in Configuration Mode.
- CLR — Resets the Count Up, Count Down and Flight timers. Cancels the previous keypress during code selection and Count Down entry. Used in Configuration Mode.
- 8 — Reduces Contrast and Display Brightness when the respective fields are displayed and enters the number eight into the Count Down timer. Used in Configuration Mode.
- 9 — Reduces Contrast and Display Brightness when the respective fields are displayed and enters the number eight into the Count Down timer. Used in Configuration Mode.

5.1.2 Code Selection

Code selection is done with eight keys (0 – 7) providing 4,096 active identification codes. Pushing one of these keys begins the code selection sequence. The new code is not activated until the fourth digit is entered. Pressing the CLR key moves the cursor back to the previous digit. Pressing the CLR key when the cursor is on the first digit of the code, or pressing the CRSR key during code entry, removes the cursor and cancels data entry, restoring the previous code. You may press the CLR key up to five seconds after code entry is complete to return the cursor to the fourth digit. The numbers 8 and 9 are not used for code entry, only for entering a Count Down time, contrast and display brightness and in the Configuration Mode.

NOTE

The selected identification code should be entered carefully, either one assigned by air traffic control for IFR flight or an applicable VFR transponder code.

- Important Codes:

1200 — The VFR code for any altitude in the US (Refer to ICAO standards elsewhere)

7000 — The VFR code commonly used in Europe (Refer to ICAO standards)

7500 — Hijack code (Aircraft is subject to unlawful interference)

7600 — Loss of communications

7700 — Emergency

7777 — Military interceptor operations (Never squawk this code)

0000 — Military use (Not enterable)

Avoid selecting code 7500 and all codes in the 7600-7777 range. These codes trigger special indicators in automated facilities. An aircraft's transponder code is used for ATC tracking purposes, therefore exercise care when making routine code changes.

5.1.3 Function Display

PRESSURE ALT — Displays the altitude data supplied to the GTX 330 in feet, hundreds of feet (i.e., flight level), or meters, depending on configuration.

FLIGHT TIME — Displays the Flight Time, controlled by the START/STOP key or by one of three airborne sources (squat switch, GPS ground speed recognition or altitude increase) as configured during installation. The timer begins when the GTX 330 determines that the aircraft is airborne.

ALTITUDE MONITOR — Activates a voice alarm and warning annunciator when altitude limit is exceeded.

COUNT UP TIMER — Controlled by START/STOP and CLR keys.

COUNT DOWN TIMER — Controlled by START/STOP, CLR, and CRSR keys. The initial Count Down time is entered with the 0 – 9 keys.

CONTRAST — This page is only displayed if manual contrast mode is selected in Configuration Mode. Contrast is controlled by the 8 and 9 keys .

DISPLAY — This page is only displayed if manual backlighting mode is selected in Configuration Mode. Backlighting is controlled by the 8 and 9 keys.

5.2 CONFIGURATION PAGES

Holding down the FUNC key and pressing the ON key provides access to the configuration pages. The FUNC key sequences forward through the configuration pages. The START/STOP button reverses through the pages, stopping at the Menu page. The CRSR key will highlight selectable fields on each page. When a field is highlighted, numeric data entry will be performed with the 0 – 9 keys and list selections will be performed with the 8 or 9 keys. Press the CRSR key to accept changes. Pressing the FUNC key moves on to the next configuration page without saving the changes. Changes made through the configuration pages are stored in EEPROM memory. To exit the configuration pages, turn the power off and then on again (without holding the FUNC key).

The configuration page sequence is as follows (menu categories are listed in parenthesis):

- ‘Jump To’ Menu
- Audio and Messages (first and second pages)
- Traffic Information
- Display Mode
- Display Backlight
- Key Backlight
- Contrast
- ARINC 429 Input #1 (first I/O Configuration page)
- ARINC 429 Input #2 (second I/O Configuration page)
- ARINC 429 Output
- RS232 Input
- Operation Configuration #1 (first Aircraft Configuration page)
- Operation Configuration #2 (second Aircraft Configuration page)
- Temperature
- Aircraft Address
- Flight ID
- Aircraft Type
- Squat Switch Setup
- Gray Code Input
- External Switch State
- Analog Input
- RS232 Input Display
- ARINC 429 Input Display #1
- ARINC 429 Input Display #2.

5.2.1 Configuration Menu Page

JUMP TO DIAGNOSTICS

CONFIGURATION MENU Page

CONFIGURATION MENU

The JUMP TO menu page provides the capability to select a configuration mode starting page without having to step through all of the pages. Select the desired section with the CRSR key and sequence through with the 8 and 9 keys. Jump to the selection by pressing the CRSR key again with the desired selection highlighted.

The FUNC key steps to the next configuration page, after which the START/STOP key reverses until stopping at the Menu page.

Selection	Description
DIAGNOSTICS	Jumps to Gray Code Input page.
DISPLAY/AUDIO	Jumps to Audio Volume page.
I/O CONFIG	Jumps to ARINC 429 INPUT #1 page.
ACFT CONFIG	Jumps to configuration Operation Configuration #1 page.

5.2.2 AUDIO MODE Pages

AUDIO VOLUME
VOICE FEMALE MESSAGE 0

AUDIO MODE (First) Page

ALTITUDE MONITOR OFF DISABLE
COUNT DOWN TIMER OFF

AUDIO MODE (Second) Page

AUDIO MODE

Selection	Description
VOICE (MALE FEMALE)	Sets the voice to male or female. Default is male voice.
VOLUME	Volume is adjusted from 0 (default) to maximum with the 8 or 9 key.
MESSAGE (0-9)	Selected tones and messages.
ALTITUDE MONITOR	Off, tone or message.
COUNT DOWN TIMER	Off, tone or message.
DISABLE	Messages either enabled or disabled.

MESSAGE

Message "0" is an on-off beeping tone. Message "1" through "5" are selected tones messages.

5.2.3 TRAFFIC INFORMATION PAGE

TRAFFIC MESSAGES OFF

TRAFFIC INFORMATION Page

TRAFFIC MESSAGES

Sets the Traffic Messages to tone, Message or Off. Traffic Information Services (TIS) provides notification of close proximity traffic.

5.2.4 DISPLAY MODE PAGE

DISPLAY MODE **AUTO** LEVEL **75**

DISPLAY MODE

DISPLAY MODE Page

Selection	Description
AUTO (Automatic)	DEFAULT. The display will automatically change between Positive mode (during the day) and Negative mode (at night), depending on the ambient light level received by the photocell.
NGTV (Negative)	The display will always be light characters on a black background, regardless of ambient lighting.
PSTV (Positive)	The display will always be black characters on a light background, regardless of ambient lighting.

LEVEL

Sets the ambient light level for AUTO mode to change between negative and positive display. The higher the number, the brighter the ambient light level to change over. This field has a range of 0 (zero) to 99, and is set to 75 at the factory.

5.2.5 DISPLAY BACKLIGHT Page

BKLT **AUTO** LVL **624** RSP TIME **4 MIN 08**
BKLT SRCE **PHOTO** SLOPE **50** OFFSET **50**

BKLT (Backlight)

DISPLAY BACKLIGHT Page

Selection	Description
MAN (Manual)	Display backlighting is controlled manually by the pilot on the GTX 330 DISPLAY page. No backlight parameters can be entered when the manual mode is selected.
AUTO (Automatic)	DEFAULT. Display backlighting is automatically controlled, based on the parameters entered on this configuration page. When AUTO is selected, the DISPLAY page does not appear to the pilot.

LVL (Level)

Shows the current level of display backlighting, based on the lighting input source (lighting bus voltage, or the ambient light if the source is PHOTO) and the settings on this configuration page. This field has a range of 0 (zero) to 999, but is not a user-entered field (display only).

RSP TIME (Response Time)

Sets the speed with which the brightness responds to ambient light changes (only for AUTO backlight mode). The higher the number, the slower the display responds. This field has a range of 3 to 7, and is set to 4 at the factory.

MIN (Minimum)

Sets the minimum brightness of the display. The higher the number, the brighter the minimum brightness. Display minimum brightness has a range of 0 (zero) to 99, and is set to 8 at the factory. It is prudent to verify that display lighting characteristics match those of other equipment in the panel under night lighting conditions.

BKLT SRCE (Backlight Source)

Selection	Description
PHOTO (Photocell)	DEFAULT. Backlight level is determined by the ambient light level as measured by the photocell on the GTX 330.
14V	Backlight level tracks a 14 volt DC aircraft lighting bus.
28V	Backlight level tracks a 28 volt DC aircraft lighting bus.
5V	Backlight level tracks a 5 volt DC aircraft lighting bus.

NOTE

If a lighting bus (any selection other than PHOTO) is selected, and the lighting bus control is turned to its minimum (daytime) setting, the display brightness will track the GTX 330 photocell.

SLOPE

Sets the sensitivity of the display brightness to changes in the input level. The higher the number, the brighter the display will be for a given increase in the input level. This field has a range of 0 (zero) to 99, and is set to 50 at the factory.

OFFSET

Adjusts the lighting level up or down for any given input level. This field has a range of 0 (zero) to 99, and is set to 50 at the factory. This may also be used to match lighting curves with other equipment in the panel.

5.2.6 KEY LIGHTING Page

The key lighting mode is always the same as the display backlight mode, so the mode must be changed on the Display Backlight configuration page. If the lighting mode is AUTO, then the key lighting parameters can be edited on this page.

KEY AUTO LVL 624 RSP TIME 4 MIN 08
KEY SRCE PHOTO SLOPE 50 OFFSET 50
KEY LIGHTING Page

KEY (Key Lighting)

Selection	Description
MAN (Manual)	Key lighting is controlled manually by the pilot on the GTX 330 DISPLAY page.
AUTO (Automatic)	Key lighting is automatically controlled based on the parameters entered on this configuration page.

LVL (Level)

Shows the current level of key lighting, based on the lighting input source (lighting bus voltage, or the ambient light if the source is PHOTO) and the settings on this configuration page. This field has a range of 0 (zero) to 999, but is not a user-entered field (display only).

RSP TIME (Response Time)

Sets the speed with which the brightness responds to ambient light changes (only for AUTO key lighting mode). The higher the number, the slower the key lighting responds. This field has a range of 3 to 7, and is set to 4 at the factory.

MIN (Minimum)

Sets the minimum brightness of the key lighting. The higher the number, the brighter the minimum brightness. Key lighting minimum brightness has a range of 0 (zero) to 99, and is set to 8 at the factory. It is prudent to verify that key lighting characteristics match those of other equipment in the aircraft panel under night lighting conditions.

KEY SRCE (Key Lighting Source)

Selection	Description
PHOTO (Photocell)	DEFAULT. Key lighting level is determined by the ambient light level as measured by the photocell on the GTX 330.
14V	Backlight level tracks a 14 volt DC aircraft lighting bus.
28V	Backlight level tracks a 28 volt DC aircraft lighting bus.
5V	Backlight level tracks a 5 volt DC aircraft lighting bus.

SLOPE

Sets the sensitivity of the key lighting brightness to changes in the input level. The higher the number, the brighter the key lighting will be for a given increase in the input level. This field has a range of 0 (zero) to 99, and is set to 50 at the factory.

OFFSET

Adjusts the key lighting level up or down for any given input level. This field has a range of 0 (zero) to 99, and is set to 50 at the factory. This may also be used to match lighting curves with other equipment in the panel.

5.2.7 CONTRAST MODE Page



CONTRAST Page

CONTRAST MODE

Selection	Description
MAN (Manual)	The display contrast is manually adjusted either here or by the pilot using the GTX 330 CONTRAST page.
AUTO (Automatic)	DEFAULT. The display contrast is automatically compensated for temperature and other factors. An offset can be entered in the contrast level adjustment described below.

CONTRAST LEVEL ADJUSTMENT

This is a “slider” bar graph control. Use the 8 key to move the graph to the left, decreasing the numbers and contrast level. Use the 9 key to move it to the right, increasing the numbers and contrast level. It is set to 50% at the factory. In manual contrast mode, this is a direct adjustment of the display contrast. In automatic contrast mode, this adjusts the offset to the automatically compensated contrast.

5.2.8 ARINC 429 CONFIGURATION Pages

ARINC 429 INPUT

The ARINC 429 INPUT Pages configure the ARINC 429 input ports. Each port can be configured independently for the desired function(s).

429 INPUT	SPEED	DATA
CHANNEL 1	LOW	OFF
CHANNEL 2	LOW	OFF

ARINC 429 INPUT (First) Page

429 INPUT	SPEED	DATA
CHANNEL 3	LOW	OFF
CHANNEL 4		OFF

ARINC 429 INPUT (Second) Page

SPEED

Selection	Description
Low	Standard low-speed ARINC 429 (nominally 12.5 kilobits per second).
High	High-speed ARINC 429 (nominally 100 kilobits per second).

INPUT DATA 1, DATA 2 DATA 3, DATA 4

Selection	Description
OFF	No unit connected to this ARINC 429 input.
GPS	Selected waypoint information.
Airdata	Altitude, temperature and speed information.
AHRS	Attitude, heading, temperature, and speed information.
EFIS/Airdata	Selected course, heading, and joystick waypoint and speed information.

ARINC 429 OUTPUT

The ARINC 429 OUTPUT Pages configure the ARINC 429 output ports. Each port can be configured independently for the desired function(s).

429 OUTPUT	DATA
CHANNEL 1	OFF
CHANNEL 2	OFF

ARINC 429 OUTPUT Page

Selection	Description
CHANNEL 1 (SPEED and DATA)	DATA SOURCE: AIRINC 735, GARMIN or OFF. DEFAULTS to OFF.
CHANNEL 2 (DATA)	DATA SOURCE: ADLP or OFF. DEFAULTS to OFF.

5.2.9 RS 232 INPUT PAGE

RS 232 INPUT (Altitude Source)

This is the electrical source for the GTX 330 altitude input.

RS-232 INPUT OFF

RS 232 INPUT Page

Selection	Description
OFF	DEFAULT. OFF. The altitude code input is not from a 429 source.
ICARUS	RS-232 serial altitude from an Icarus Instruments 3000.
SHADIN-ADC	RS-232 serial altitude from a Shadin 9628XX-X family of Air Data Computers and Fuel/Air Data Computers.
SHADIN-ALT	RS-232 serial altitude from a Shadin 8800T, 9000T, 9200T.

5.2.10 OPERATION CONFIGURATION PAGES

VS RATE 0000^{f_m} FORMAT FLIGHT LVL
VFR ID 1200 ALT ALRT DEV 000^{f_t}
First CONFIGURATION Page

VS RATE (Vertical Speed Rate)

This field is the typical vertical speed for climb/descent of the aircraft. This number determines when a climb or descent arrow is displayed on the PRESSURE ALT page of the GTX 330. The range is 0 (zero) feet per minute to 9999 feet per minute. It is set to 500 fpm at the factory.

FORMAT (Altitude Format)

This field determines how the pressure altitude will be shown on the GTX 330 display.

Selection	Description
FLIGHT LVL (Flight Level)	DEFAULT. The pressure altitude is displayed in hundreds of feet. For example, a pressure altitude of 12,300 feet is displayed as "FL 123".
FEET	Pressure altitude is displayed in feet.
METERS	Pressure altitude is displayed in meters.

VFR ID (VFR Transponder Code)

This field is the four-digit code that will be selected when the user presses the GTX 330 VFR key. In the United States, 1200 is the VFR code for any altitude. It is set to 1200 at the factory.

ALTITUDE ALERT DEVIATION (Altitude Format)

This field determines the amount of altitude difference from selected altitude to generate an altitude alert deviation.

SQUAT SWITCH

SQUAT SWITCH? NO SENSE LOW
DELAY TIME 24 AUTO FLT TMR? YES
Second CONFIGURATION Page

The GTX 330 Flight Timer and the Auto Standby feature may be based on the squat switch state. The squat switch field may be set to either YES or NO.

DELAY TIME

This is the number of seconds the aircraft must be on the ground before the AUTO STANDBY feature automatically switches to standby mode when the airborne source is the squat switch. It has a range of 0 (zero) seconds to 99 seconds, and is set to 24 seconds at the factory.

AUTO FLIGHT TIMER

Available choices are YES or NO. Selecting YES starts the flight timer when the squat switch senses lift off.

5.2.11 TEMPERATURE PAGE

SENSOR INSTALLED

Sets the Sensor to YES or NO. Default is NO.

UNITS

Sets the units to degrees Fahrenheit or Centigrade. Default is degrees F.



5.2.12 MODE S Address Entry Pages

Aircraft Registration or Flight ID Number Pages

NOTE

It is VERY important to enter the Mode S address correctly in the GTX 330.

During production of a GTX 330 the unit is initially set with an address of 0. The software recognizes this as an invalid address. When the unit is powered on for the first time, it will prompt the user to enter a valid aircraft address. (Addresses can be entered beginning at step 5 below and ending after step 9 is completed.) Once the aircraft address is entered, the unit will remain on in the mode that it was turned on.

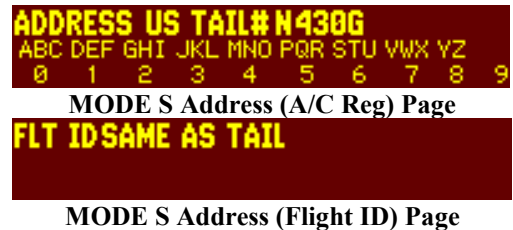

Or, if the unit is not being turned on for the first time, with the unit powered off:

1. Press and hold the **FUNC** key while powering on the unit.
2. Power the unit on by pressing the **ALT** key or turn the unit on with the avionics master switch. The unit will perform a self-test routine and display a "Jump to Diagnostics" page.
3. Press the **FUNC** key repeatedly to toggle through the pages until you come to the address entry page.
 - a. It will appear either as ADDRESS HEX _ _ _ _ _ .
 - b. Or as ADDRESS US TAIL# N _ _ _ _ .
4. If the alternate option is required, press the **8** or **9** key to move to the correct selection.
5. For entering either the address hex code or the US registration number, press the **CRSR** key 1 time. (This will highlight the address field).
7. Enter the aircraft address using the number keys. Press a key repeatedly to scroll through the digit and different alpha characters for that key.
8. Press the **CRSR** key to select the next numeric entry field. Again press a number key as stated in step 7 and move onto the next field, repeating the process until the complete number is entered.
9. When finished, press the **CRSR** key again to accept the number entry.
10. Use the **FUNC** key to toggle through the rest of the setup pages until it rolls back around to the aircraft address page.
11. Verify that the address is correct. The unit now contains a Mode S address and may be turned off.

MODE S Aircraft Type Page

AC TYPE **>=15.5K_{Lb}** MAX A/S **<=300_{k_t}**
ACQ SQTR INHIBITED **NO**
MODE S (A/C Type) Page

Selection	Description
AC TYPE	ROTOR, >15.5K Lb, <15.5K Lb, or UNKNOWN.
MAX AIRSPEED	<75 Kts, <150 Kts, <300 Kts, >300 Kts, or UNKNOWN.
ACQ SQUITTER INHIBITED	YES OR NO.

AIRCRAFT TYPE

Sets the AIRCRAFT TYPE Message to ROTOR, to a weight of Less Than 15,500 pounds, More Than 15,500 pounds, or Unknown weight. Defaults to Less Than or equal to 15,500 pounds.

MAXIMUM AIRSPEED

Sets the AIRCRAFT AIRSPEED Message to a speed of Less Than or equal to 75 Knots, Less Than or equal to 150 Knots, Less Than or equal to 300 Knots, More Than 300 Knots, or Unknown airspeed. Defaults to Less Than or equal to 300 Knots.

ACQ SQUITTER INHIBITED

Sets the ACQ SQUITTER INHIBITED to YES or NO. Defaults to NO.

5.2.13 GRAY CODE INPUT Page

GRAY CODE

daaaabbbccc
GRAY 4124124124 DECODED
CODE 0000000000 ALTITUDE 12300_{ft}
GRAY CODE INPUT Page

This field shows the status (1 = ground, 0 = open) of each of the ten gray code altitude inputs. This information may aid in installation troubleshooting.

DECODED ALTITUDE

This field displays the gray code altitude input in feet. Verify that it is the correct altitude.

5.2.14 EXTERNAL SWITCH STATE Page



IDENT

This field displays the state of the EXTERNAL IDENT discrete input. The box is filled when EXTERNAL IDENT is grounded.

STANDBY

This field displays the state of the EXTERNAL STANDBY discrete input. The box is filled when EXTERNAL STANDBY is grounded.

SQUAT

This field displays the state of the SQUAT SWITCH input. The box is filled when the SQUAT SWITCH input is active (the aircraft is on the ground as configured on the SETUP 2 page).

5.2.15 ANALOG INPUT Page



5.2.16 RS 232 INPUT Page



5.2.17 429 CHANNELS Pages

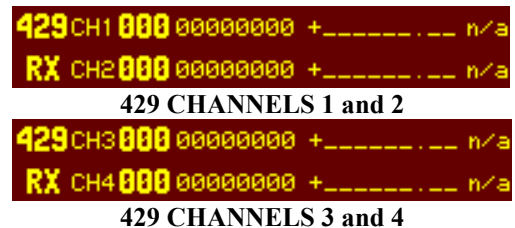

This page intentionally left blank

APPENDIX A CERTIFICATION DOCUMENTS

A.1 Continued Airworthiness

Other than for regulatory periodic functional checks, maintenance of the GTX 330 is “on condition” only. Refer to the GTX 330 Maintenance Manual, (Garmin P/N 190-00207-05). Periodic maintenance of the GTX 330 is not required.

This section provides assistance to the installing agency in preparing Instructions for Continued Airworthiness (ICA) in response to Bulletin Number HBAW 98-18, “Checklist for Instructions for Continued Airworthiness for Major Alterations Approved Under the Field Approval Process”, effective 10/7/98.

Aviation Authority approved installers are hereby granted permission to reference appropriate service instructions and excerpts from this Installation Manual to accomplish the Instructions for Continued Airworthiness. This permission does not construe suitability of the documents. It is the applicant’s responsibility to determine the suitability of the documents for the ICA.

Following is a suggested ICA for a GARMIN GTX 330 unit installation. Some of the checklist items do not apply, in which case they should be marked “N/A” (Not Applicable).

INSTRUCTIONS FOR CONTINUED AIRWORTHINESS, GARMIN GTX 330

1. Introduction

[Aircraft that has been altered: Registration (N-) number, Make, Model and Serial Number]

Content, Scope,

Purpose and Arrangement: This document identifies the Instructions for Continued Airworthiness for the modification of the above aircraft by installation of a GARMIN GTX 330.

Applicability: Applies to aircraft altered by installation of the GARMIN GTX 330.

Definitions and Abbreviations: None, N/A.

Precautions: None, N/A.

Units of Measurement: None, N/A.

Referenced Publications: GARMIN GTX 330 Installation Manual, P/N 190-00207-02

GARMIN GTX 330 Maintenance Manual, P/N 190-00207-05

GARMIN STC # [applicable STC number for the specific model installed, refer to Appendix B of this manual].

GARMIN GTX 330 Pilot’s Guide, P/N 190-00207-xx.

Distribution: This document should be a permanent aircraft record.

2. Description of the Alteration

Installation of the GARMIN GTX 330, with interface to Encoding Altimeter or Blind Encoder. Refer to section 4 and figures 4-1 and 4-2 of this manual for interconnect information. Antenna installation, removal and replacement should be in accordance with applicable provisions of AC43.13-1B and 43.13-2A.

3. Control, Operation Information

Refer to the GTX 330 Pilot’s Guide.

4. Servicing Information

N/A

5. Maintenance Instructions

Maintenance of the GTX 330 is 'on condition' only. Periodic maintenance is not required. Refer to the GTX 330 Maintenance Manual.

6. Troubleshooting Information

Refer to the GTX 330 Maintenance Manual.

7. Removal and Replacement Information

Refer to section 2 of this manual. If the unit is removed and reinstalled, a functional check of the equipment should be conducted in accordance with section 5 of this manual.

8. Diagrams

Refer to section 3 and section 4 of this manual.

9. Special Inspection Requirements

N/A

10. Application of Protective Treatments

N/A

11. Data: Relative to Structural Fasteners

Antenna installation, removal and replacement should be in accordance with applicable provisions of AC43.13-1A and 43.13-2A. Also, refer to section 2 of this manual.

12. Special Tools

N/A

13. This Section is for Commuter Category Aircraft Only

A. Electrical loads: Refer to section 1.3 of this manual.

B. Methods of balancing flight controls: N/A.

C. Identification of primary and secondary structures: N/A.

D. Special repair methods applicable to the airplane: Antenna installation, removal, and replacement should be in accordance with applicable provisions of AC43.13-1B and 43.13-2A.

14. Overhaul Period

No additional overhaul time limitations.

15. Airworthiness Limitation Section

N/A.

16. Revision

To revise this ICA, a letter must be submitted to the local FSDO with a copy of the revised FAA Form 337, and revised ICA. The FAA inspector accepts the change by signing Block 3 and including the following statement:

“The attached revised/new Instructions for Continued Airworthiness (date _____) for the above aircraft or component major alteration have been accepted by the FAA, superseding the Instructions for Continued Airworthiness (date _____).”

17. Assistance

Flight Standards Inspectors have the resources to respond to questions regarding the ICA.

Implementation and Record Keeping

For major alterations performed in accordance with FAA field approval policy, the owner/operator operating under Part 91 is responsible for ensuring that the ICA is made part of the applicable section 91.409 inspection program for their aircraft. This is accomplished when a maintenance entry is made in the aircraft's maintenance record in accordance with section 43.9. This entry records the major alteration and identifies the original ICA location (e.g., Block 8 of FAA Form 337, dated _____) along with a statement that the ICA is now part of the aircraft's inspection/maintenance requirements.

A.2 ENVIRONMENTAL QUALIFICATION FORM

NOMENCLATURE: GTX 330 Airborne ATC/Mode S Transponder Equipment
TYPE/MODEL/PART NO.: 010-00230-(), which includes 011-00455-()
TSO/JTSO COMPLIANCE: TSO – C112 Class 2A, and TSO - C74c Class 1A
MANUFACTURER'S SPECIFICATION AND/OR OTHER APPLICABLE SPECIFICATION: 004-00099-00 Minimum Performance Specification

MANUFACTURER: GARMIN INTERNATIONAL

ADDRESS: 1200 E 151st St, Olathe, Kansas 66062

Conditions	RTCA DO-160D Section	Description of Conducted Tests
Temperature and Altitude	4.0	Equipment tested to Categories A2 B2 F1
Low Temperature	4.5.1	-45 degrees C
High Temperature	4.5.2. & 4.5.3	+70 degrees C
In-Flight Loss of Cooling	4.5.4	Cooling air not required but highly recommended
Altitude	4.6.1	55,000 Feet
Decompression	4.6.2	
Overpressure	4.6.3	
Temperature Variation	5.0	Equipment tested to Category B
Humidity	6.0	Equipment tested to Category A
Shock	7.0	Equipment tested to Category B
Vibration	8.0	<p>Equipment tested in each aircraft type to aircraft zone 2. Aircraft Type 2 and 6 were tested to Category S2, Vibration level B2. Aircraft Type 3, 4, and 5 were tested to Category S, Vibration level M.</p> <p>Note: DO-160D vibration level M modified to increase level to RTCA DO-160C Curve N for Helicopters as follows-0.1 inches peak-to-peak double amplitude from 5 Hz to 17 Hz, 1.5g-Pk from 17 Hz to 500 Hz.</p>

Conditions	Section	Description of Conducted Tests
Explosion	9.0	Equipment identified as Category X, no test required
Waterproofness	10.0	Equipment identified as Category X, no test required
Fluids Susceptibility	11.0	Equipment identified as Category X, no test required
Sand and Dust	12.0	Equipment identified as Category X, no test required
Fungus	13.0	Equipment identified as Category X, no test required
Salt Spray	14.0	Equipment identified as Category X, no test required
Magnetic Effect	15.0	Equipment tested to Class Z
Power Input	16.0	Equipment tested to Category BZ
Voltage Spike	17.0	Equipment tested to Category A
Audio Frequency Conducted Susceptibility	18.0	Equipment tested to Category Z
Induced Signal Susceptibility	19.0	Equipment tested to Category Z
Radio Frequency Susceptibility	20.0	Equipment tested for conducted susceptibility to Category T, radiated susceptibility to Category T, and pulse test to Category T.
Radio Frequency Emission	21.0	Equipment tested to Category B, Equipment tested to Category M up to 2 GHz.
Lightning Induced Transient Susceptibility	22.0	Equipment identified as Category A3E3
Lightning Direct Effects	23.0	Equipment identified as Category X, no test required
Icing	24.0	Equipment identified as Category X, no test required
Electrostatic Discharge (ESD)	25.0	Equipment identified as Category X, no test required

APPENDIX B

STC PERMISSION

Consistent with N8110.69 or Order 8110.4, Aviation Authority approved installers are hereby granted permission to use STC #(xxxxxxx) data to modify aircraft.

To be supplied