

2 INSTALLATION

2.1 Introduction

This section provides hardware equipment information for installing the GDL 69/69A and optional GRT 10, cabling for the XM antenna (GA 37, GA 55, GA 55A, or GA 57), and related hardware. Installation of the GDL 69/69A and GRT 10 should follow the aircraft TC or STC requirements. For interconnects with the GDU 104x, MX20 MFD, GMX 200 MFD, 400W/500W series or 400/500 series refer to Appendix D of this manual. For installation information on the GDU 104x, MX20 MFD, GMX 200 MFD, 400W/500W series or 400/500 series, refer to their installation manuals.

Installation of the XM antennas is covered under separate Garmin GA Antenna AML STC number SA01695SE.

2.2 Pre-Installation Information

Always follow acceptable avionics installation practices per FAA Advisory Circulars (AC) 43.13-1B, 43.13-2A, or later FAA approved revisions of these documents.

Follow the installation procedure in this manual as it is presented for a successful installation. Read the entire manual before beginning the procedure. Prior to installation, consider the structural integrity of the GDL 69/69A and GRT 10 installation as defined in AC 43.13-2A, Chapter 1 and evaluate the necessity for audio suppression inputs in accordance with the GDL 69A Audio Limitations in Section 6. Perform the post installation checkout before closing the work area in case problems occur.

Complete an electrical load analysis in accordance with AC 43.13-1B, Chapter 11, on the aircraft prior to starting modification to ensure aircraft has the ability to carry the GDL 69/69A and GRT 10 load. Refer to Section 2.8 for the power consumption of the GDL 69/69A and the GRT 10. Document the results of the electrical load analysis on FAA Form 337.

2.3 Installation Materials

2.3.1 Configurations Available

The GDL 69, GDL 69A, and GRT 10/GRC 10 wireless remote system can be ordered in different kits, each of which may contain components listed in the following table.

Table 2-1. GDL 69/69A Kit Contents

	Description	Part Number
	GDL 69 XM Weather Data Receiver	011-00986-00
	GDL 69A XM Weather/Audio Data Receiver	011-00987-00
	Back Plate Assembly	011-00796-35
	Remote Mount Rack GDL 69	115-00658-00
	Connector Kit Assembly	011-00997-00
	Configuration Module Assembly	011-00979-00
OR	GA 37 XM and GPS Antenna	013-00245-00
	GA 55 XM Antenna	011-01033-00
	GA 55A XM Antenna	011-01153-00
	GA 57 XM and GPS Antenna (Not recommended for new installations)	011-01032-00
	Rack Nut Plate, 2 POS	011-00915-00
	Modular Rack	115-00411-00

Table 2-2. GRT 10 Transceiver Kit Contents

Description	Part Number
GRT 10 (Wireless Transceiver)	011-01557-00
Connector Kit	011-01556-00

Table 2-3. GRC 10 Remote Control Kit Contents

Description	Part Number
GRC 10 (Wireless Remote Control)	011-01558-00
Two AA Batteries	360-00004-00
GRC 10 User's Guide	190-00355-11

2.3.2 Equipment Required But Not Supplied

Hardware for the GDL 69/69A:

- Wire: MIL-W-22759/16 or equivalent
- Shielded Wire: MIL-C-27500 or equivalent

Hardware for Remote Mount Rack:

- Vertical Mount: Four #8-32 Pan Head Screws (MS35206, AN526 or equivalent)
- Horizontal Mount: Four #6-32 x 100° Counter-Sunk Flat Head Screw (MS24693, AN507R or equivalent)
- Circuit Breaker: Appropriate for selected wire size

Hardware for GRT 10 Transceiver:

- Four #6-32 Pan Head Screws (MS35206, AN526 or equivalent)

2.4 Equipment Mounting

2.4.1 Rack Location and Installation

The GDL 69/69A and optional GRT 10 may be mounted in a pressurized or unpressurized location, neither unit requires forced-air cooling. When mounting, avoid locating the equipment near sources that produce high levels of heat. The GDL 69/69A has two mounting rack options available, the remote rack and the modular rack for use with the G1000 system.

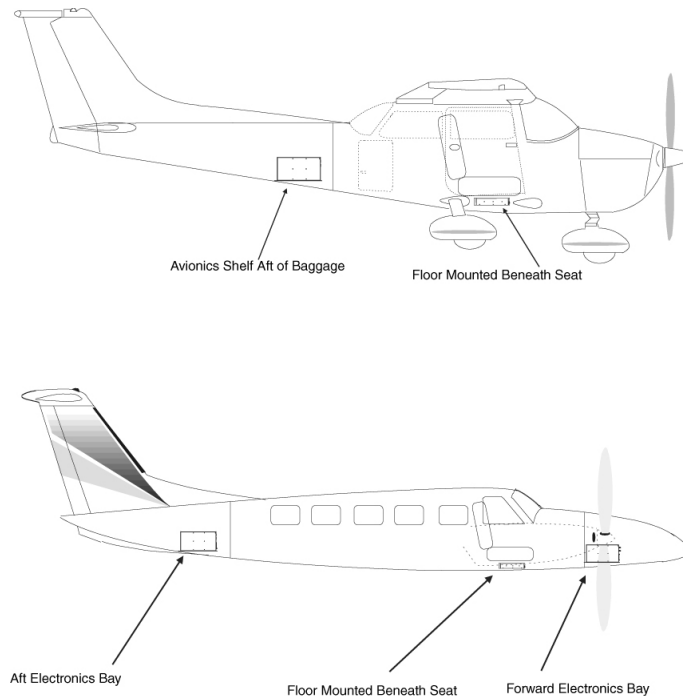

Figure 2-1. Suggested Mounting Locations for Remote Rack

2.4.2 Remote Mount Rack

The remote mount rack can be installed in a variety of locations, such as the electronics bay, behind the instrument panel, under the seat or behind the rear baggage area. Leave sufficient clearance between the GDL 69/69A and any obstruction. Install the rack in accordance with AC43.13-2A Chapter 2 Radio Installations. The remote mount rack should be mounted to a surface known to have sufficient structural integrity to withstand additional inertial forces imposed by a 1.86 pound unit (1.72 lbs. for GDL 69). If it is necessary to build a shelf or bracket to mount the GDL 69/69A rack or if it is not certain that the chosen location is of sufficient structural integrity, refer to Appendix C. Refer to Figure 1-4 for the GDL 69/69A remote mount rack dimensions. The rack can be mounted vertically using four 8-32 pan head screws (MS35206, AN526 or equivalent.) It can also be mounted horizontally using four 6-32 100° counter-sunk flathead screws (MS24693, AN507R or equivalent.) Ensure that the rack has a ground path to the airframe by having at least one mounting screw in contact with the airframe to minimize radiated electromagnetic interference (EMI).

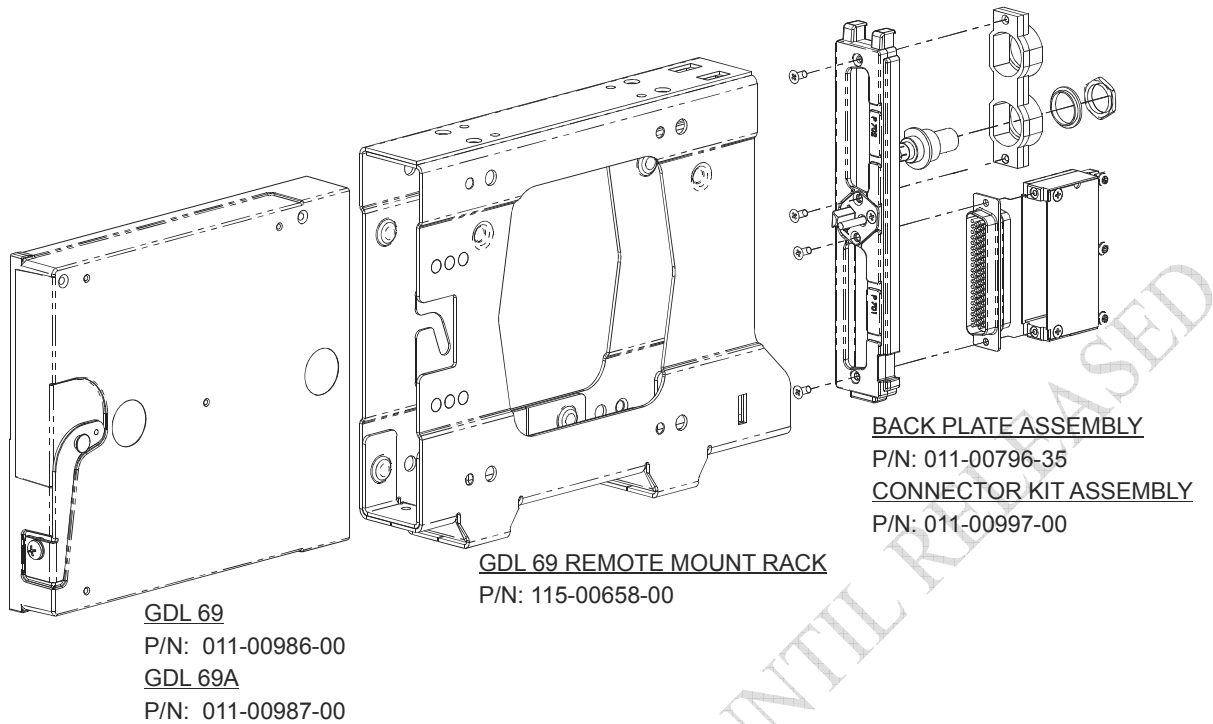

Figure 2-2. GDL 69/69A Remote Mount Rack

2.4.3 G1000 Modular Rack

The G1000 modular rack is used to install the GDL 69/69A in the standard G1000 integrated avionics system rack. This modular rack may be mounted behind the instrument panel or in the avionics bay. Refer to Figure 1-5 for the GDL 69/69A G1000 modular rack dimensions. This STC covers the installation of the GDL 69/69A modular rack into the installed G1000 integrated avionics system rack, but does not cover the installation of the G1000 integrated avionics system rack.

2.4.4 GRT 10 Mounting

The optional GRT 10 transceiver is mounted using four #6 pan head screws (MS35206, AN526, or equivalent) onto a solid surface. Install the GRT 10 in accordance with AC43.13-2A Chapter 2 Radio Installations. Because the weight of the GRT 10 is only 0.27 lbs, the impact of the weight to the surrounding structure is negligible and no structural validation procedures are required. If the GDL 69A is mounted behind a metal bulkhead, the GRT 10 should be mounted inside the cabin to get better signal strength. For optimal performance, the end of the GRT 10 opposite the 9-pin D-sub should face the cabin.

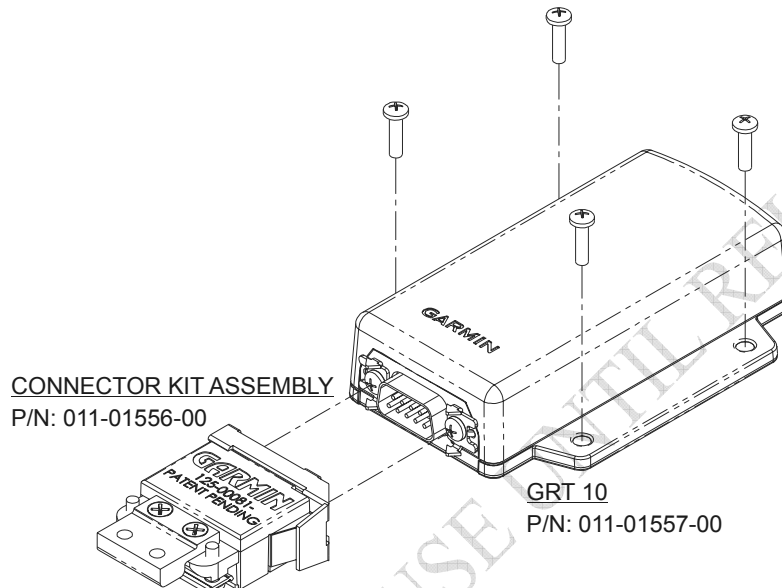

Figure 2-3. GRT 10 Mounting

2.4.5 Remote Switches

Installation of rocker switches should be made on a flat surface and located at a convenient location within the cabin. Each rocker switch installed must be properly marked of its function. Use of rocker switches vs. toggle switches will prevent the possibility of raising and lowering the volume at the same time or raising and lowering the channels at the same time. Wire used for discrete switches should be 24 AWG (MIL Spec M22759) and should be routed as appropriate, avoiding kinking or sharp bends. Figure 2-4 shows typical rocker switches.

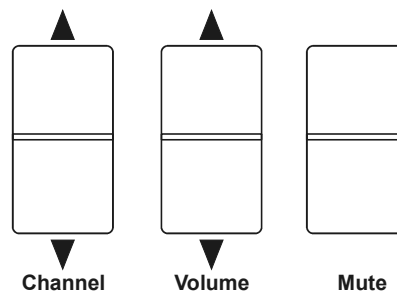

Figure 2-4. Typical Rocker Switches

NOTE



Remote switches can be installed even if a GRT 10 is installed.

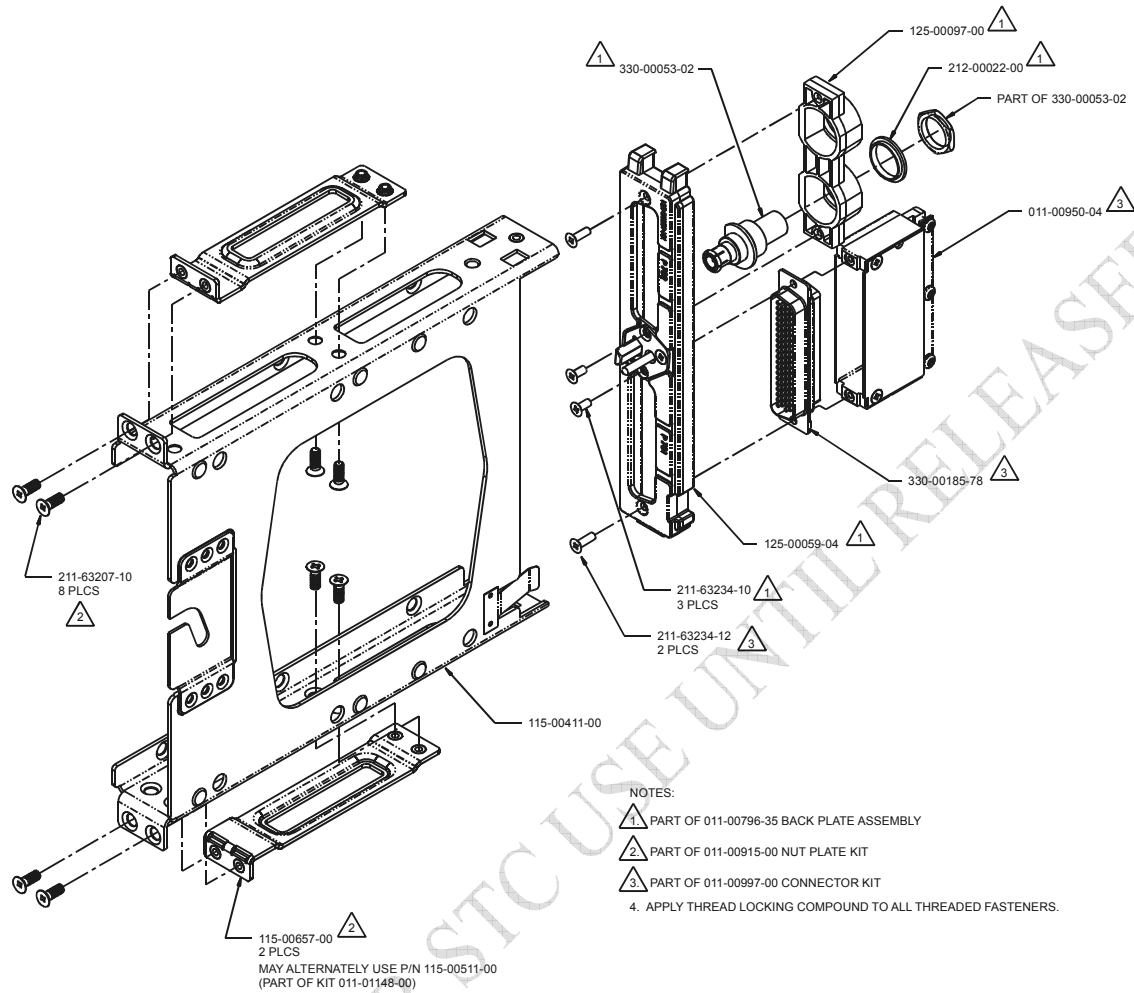

Figure 2-5. Modular Rack for the G1000

2.5 Cabling and Wiring

Wiring should be installed in accordance with AC 43.13-1B Chapter 11. When wire separation cannot be achieved, the following issues should be addressed:

- The cable harness should not be located near flight control cables and control, high electrical capacity lines or fuel lines
- The cable harness should be located in a protected area of the aircraft
- Do not route cable near high-energy sources

Refer to the interconnection diagrams in Appendix D for the appropriate wiring. Once the cable assemblies have been made, attach the cable connector to the rear of the rack. Route the wiring bundle as appropriate. Avoid sharp bends.

For the GDL 69/69A use 22 or 24 AWG wire for all connections except for power. Use 22 AWG for power/ground. For the GRT 10 use 22 AWG wire for all connections including power/ground.

After the GDL 69/69A cable assemblies are made assemble the backshell as shown in Figure 2-7. Then install the backshell connector to the rear plate using the screws provided in the connector kit. After the rack is installed, assemble the rear plate into the rack.

2.5.1 Wiring Harness

Allow adequate space for installation of cables and connectors. The installer supplies and fabricates all of the cables. Except for the antenna connection, all electrical connections are made through a 78-pin D-sub (GDL 69/69A) and 9-pin D-sub (GRT 10) connectors provided by Garmin. Construct the wiring harness according to the information contained in this and the following sections. Cable lengths will vary depending upon installation. Strip all wires going to the D-sub connectors 1/8". Insert the wire into the pin and crimp with one of the recommended (or equivalent) crimping tools. Insert the pin into the D-sub connector housing locations as specified by the interconnect drawing in Appendix D. Verify the pin is properly engaged into the connector by gently tugging on the wire. Route and secure the cable run from the GDL 69/69A and GRT 10 to the other units away from sources of electrical noise.

Section 3 defines the electrical characteristics of all input and output signals. Required connectors and associated hardware are supplied with the connector kit. See Appendix D for interconnect wiring diagrams.

CAUTION



Check wiring connections for errors before inserting the GDL 69/69A into the rack or mounting bracket or connecting the 9-pin D-sub to the GRT 10. Incorrect wiring could cause component damage.

Table 2-4. Pin Contact Part Numbers

Wire Gauge	78-pin connectors 22-28 AWG	9-pin connectors 20-24 AWG
Garmin P/N	336-00021-00	336-00022-00
Military P/N	M39029/58-360	M39029/63-368
AMP	204370-2	205090-1
Positronic	MC8522D	M39029/63-368
ITT Cannon	030-2042-000	031-1007-42

Table 2-5. Recommended Crimp Tools

Wire Gauge	Hand Crimping Tool	20-24 AWG	
		Positioner	Insertion/ Extraction Tool
Military P/N	M22520/2-01	M22520/2-09	M81969/1-04
Positronic	9507	9502-3	M81969/1-04
ITT Cannon	995-0001-584	995-0001-739	N/A
AMP	601966-1	601966-6	91067-1
Daniels	AFM8	K42	M81969/1-04
Astro	615717	615725	M81969/1-04

NOTE



Insertion/extraction tools from ITT Cannon are all plastic; others are plastic with metal tip. Non-Garmin part numbers shown are not maintained by Garmin and are subject to change without notice.

2.5.2 GDL 69/69A Backshell Assembly and D-Sub Connector

2.5.2.1 GDL 69/69A Connector Assembly

1. Backshell Cast Housing: Provides a mounting point for all other connector accessories.
2. Configuration Module: Installation details provided in Section 2.5.2.2.
3. D-sub Connector: Installation details provided in Section 2.5.2.2.
4. Spider Ground System: Allows shield grounds to be made to the backshell housing. Installation details provided in Section 2.5.2.5.
5. Strain Relief Tab: Provides strength and support to wiring bundles.
6. Backshell Lid: Provides easy access when servicing connector.

Table 2-6. GDL 69/69A Connector Assembly

Item Number (Reference Figure 2-6)	Description	Qty	Garmin Part Number
1	Backshell, with Config 50/78 Pin	1	125-00085-00
2	PCB Assembly, Configuration Module	1	012-00605-00
3	Connector, High Density, 78 Pin	1	330-00185-78
4	Wire Harness, Backshell Ground	1	320-00212-00
5	Clamp, Backshell, 62/78 Pin	1	115-00499-03
6	Cover, Backshell, 50/78 Pin	1	115-00500-04
7	Screw, 4-40 x .187 FLHP100, Stainless Steel	2	211-63234-06
8	Screw, 4-40 x .375, Phillips, Stainless Steel	3	211-60234-10
9	Screw, 4-40 x .250, FLHP, Stainless Steel	2	211-63234-08

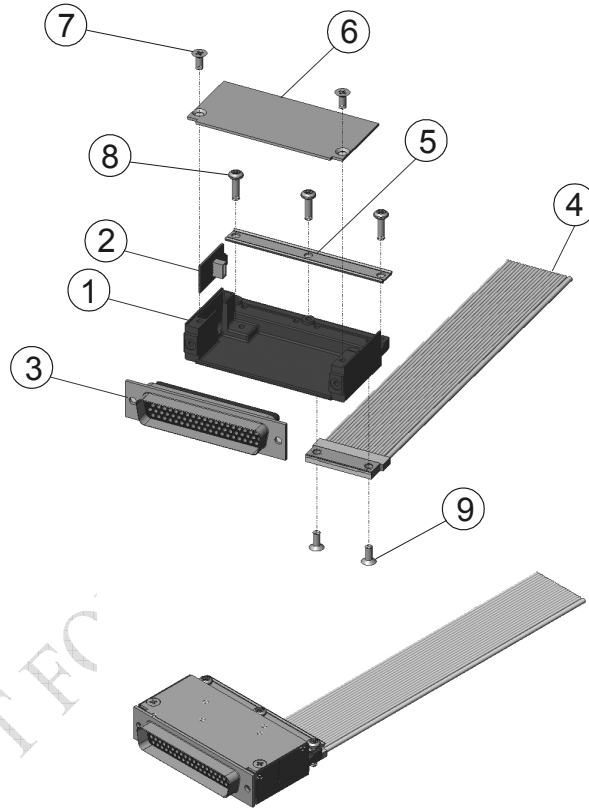

Figure 2-6. Garmin Connector Assembly

2.5.2.2 Configuration Module Installation for GDL 69/69A

The GDL 69/69A connector kit includes one Garmin backshell assembly. The backshell assembly houses the configuration module. Garmin's backshell also gives the installer the ability to easily terminate shield grounds at the backshell housing using the Spider grounding kit. Refer to Figure 2-7 for details and item numbers referenced below.

1. Crimp pins (4) onto each wire of the four-conductor wire harness (3). Strip 1/8" of insulation from each wire prior to crimping.
2. Insert newly crimped pins and wires (3, 4) into the appropriate connector housing (5) location as specified by the interconnect drawings in Appendix D.
3. Apply the spacer (2) by wrapping it around the PCB Board (1) making sure to insert the plastic connector mounted on the board into the provided hole of the spacer.
4. Plug the four-conductor wire harness (3) into the connector on the PCB Board (1).
5. Insert into the backshell (6) recess, PCB Board (1) with pad (2) in position.
6. Attach cover (7) to backshell (6) using screws (8).

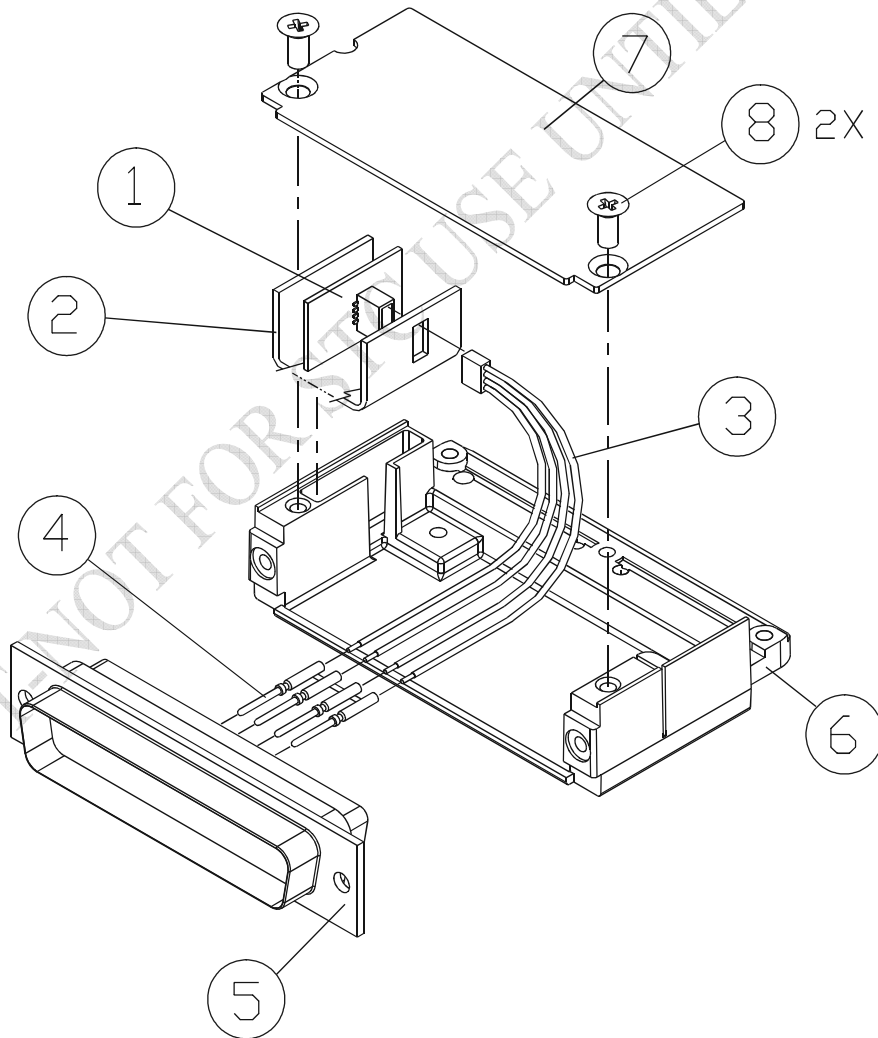

Figure 2-7. Backshell Assembly

2.5.2.3 Spider Grounding Installation for GDL 69/69A

The Spider Grounding Kit, part of the connector kit, allows shielded cables that go to a backshell to be terminated to the backshell. Twenty AWG #24 wires are available to splice with the cable shields. The wires all terminate to a terminal that is fastened to the backshell. A single AWG #16 wire provides ground reference to the terminal, thereby grounding all Spider leads to the aircraft.

Spider Kit terminals are screwed to the backshell using the tapped holes provided.

Table 2-7. Spider Kits

Reference Figure 2-7	Description	Qty. Included	Garmin Part Number
Spider Kit w/ 21 Conductors: 011-00980-00 (Included in 011-00997-00)			
2	Wire Harness, Backshell Ground, 21 Conductor	1	320-00212-00
3	1 Conductor, 24", AWG #16		
4	20 Conductor, 6", AWG #24		
5	Screw, 4-40 x .250, FLHP 100°, SS/P, Nylon	2	211-63234-08

2.5.2.4 Spider Parts List

The following table provides a list of parts needed to install a Spider kit. Most parts for this installation are included in the Spider installation kits shown in Table 2-7. Some are to be provided by the installer. The following tables show the list of required parts as well as callouts for the drawings shown in Figure 2-8.

Table 2-8. Spider Installation Required Parts

Reference Figure 2-8	Description	Qty. Included	Garmin Part Number/MIL Spec
1	Cast Housing from Garmin Backshell Kit	0	011-00950-()
2, 3, 4, 5	Spider Kit	1	011-00980-00 or 011-00980-01
6	Shield Termination (method optional, see Step 3 below)	0	Parts used depend on method chosen
7	Multiple-Conductor Shielded Cable (2 –conductor demonstrated here)	0	Reference Interconnect Diagrams
8	Pins	0	336-00021-00
9	Ring Terminal	0	MS25036-152
10	Strain Relief from Garmin Backshell Kit	0	011-00950-()
11	Screw, 4-40x.375, PHP, SS/P, w/NYL	0	211-60234-10

2.5.2.5 Spider and Connector Assembly Procedure

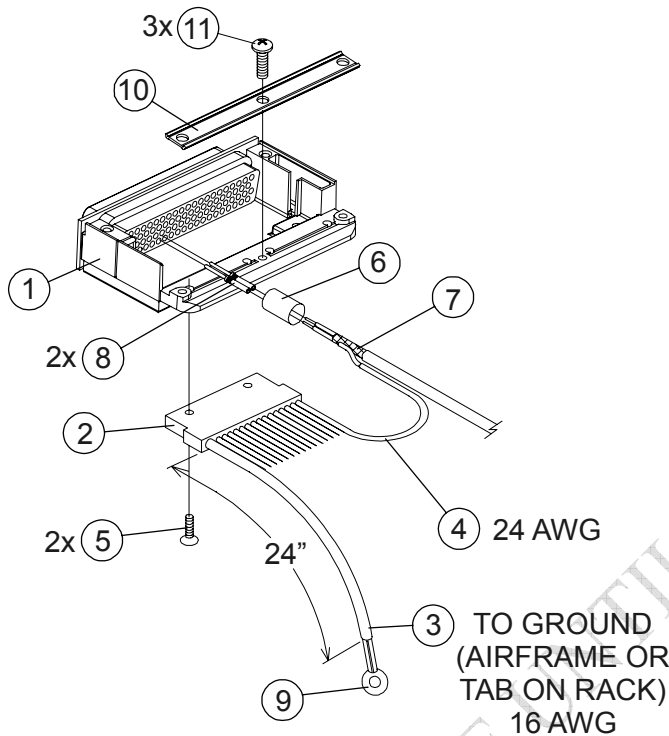

Figure 2-8. Spider Installation Drawing

1. At one end of the shielded cable (7), strip back 2.0" to 3.5" of jacket while retaining the shield. Trim away enough to leave 0.5" of shield exposed.
2. Strip 1/8" of insulation from one of the AWG #24 wires (4) on the Spider.
3. Connect the prepared AWG #24 Spider wire (4) to the shield (7) using an approved shield termination technique.

Installation Options:

- a) Slide a solder sleeve (6) onto the prepared wire assembly (4, 7) and shrink with a heat gun. The size of solder sleeve must accommodate the number of conductors present in the cable. Reference the following MIL-Specs for solder sleeves (M83519/1-1, M83519/1-2, M83519/1-3, M83519/1-4, M83519/1-5).
- b) Solder the prepared wire assembly (4, 7). Slide a piece of shrink tube (6) onto the prepared wire assembly and shrink using a heat gun. The size of shrink tube must accommodate the number of conductors present in the cable.
4. Strip 1/8" of insulation from the shielded cable end and crimp a pin (8) to each of the conductors (7).
5. Insert crimped pins and wires (7, 8) into the appropriate housing location as specified by the installation wiring diagrams.
6. Repeat steps 1 through 3 as needed for the remaining shielded cables (7). Use only one Spider wire (4) per shield. Remaining AWG #24 wires should be tied back and dressed with shrink tubing.
7. Wrap the cable bundle with Silicone Fusion Tape (Garmin P/N: 249-00114-00 or a similar version) at the point where the backshell strain relief (10) and cast housing (1) contacts the cable bundle. Separation of the bundle into two smaller bundles, wrapped individually, may make installation of the strain relief easier.
8. Place the smooth side of the backshell strain relief (10) across the cable bundle and secure using the three screws (11).

WARNING



Placing the strain relief grooved side across the cable bundle may cause damage to wires.

9. Attach the Spider terminal (2) to the backshell (1) by inserting the two screws (5) into the tapped holes on the backshell (1).
10. Attach a ring terminal (9) to the AWG #16 wire (3) length 24" and terminate to ground. The ground connection can be made using either the closest aircraft ground or with tabs on racks. Trimming of this wire to the shortest practical length before attaching the ring terminal is recommended to reduce the effects of noise and interference. Do not extend this wire's length.

DRAFT-NOT FOR STC USE UNTIL RELEASED

2.5.3 GRT 10 Backshell Assembly and D-sub Connector

2.5.3.1 GRT 10 Connector Assembly

1. Backshell Cast Housing: Provides a mounting point for all other connector accessories.
2. D-sub Connector: Installation details provided in Section 2.4.4.
3. Shield Block Ground Kit: Allows shield grounds to be made to the backshell housing. Installation details provided in Section 2.5.3.3.
4. Strain Relief Tab: Provides strength and support to wiring bundles.
5. Backshell Lid: Provides easy access when servicing connector.

Table 2-9. GRT 10 Backshell Assembly

Reference Figure 2-9	Description	Garmin P/N	Notes
1	Cast Housing (From Garmin Backshell Kit)	125-00081-00	[2]
2	Shield block	117-00147-00	[3]
3	Screw, 4-40 x.250, FLHP100°, SS/P, Nylon	211-63234-08	[3]
4	Multiple Conductor Shielded Cable (See Interconnect Diagrams, Appendix D)	As Required	[4]
5	Shield Terminator	As Required	[4], [5]
6	Wire, Insulated (20 – 22 AWG)	As Required	[4], [5]
7	Socket Contacts	336-00022-00	[1]
8	Ring terminal, #8, insulated, 18-22 AWG, 14-16 AWG	MS25036-149, MS25036-153, MS25036-156	[4]
9	Screw, PHP, 8-32x.312", Stainless or Cad Plated Steel	MS51957-42, MS35206-242	[4]
10	Split Washer, #8, (.045" compressed thickness) Stainless or Cad-plated steel	MS35338-137, MS35338-42	[4]
11	Flat Washer, #8, .032" thick, .174"ID, .375" OD, Stainless or Cad Plated Steel	NAS1149CN832R, NAS1149FN832P	[4]
12	Silicon Fusion Tape	249-00114-00	[4]
13	Strain Relief	115-00499-00	[2]
14	Screw, 4-40x.375, PHP, SS/P, with Nylon	211-60234-10	[2]
15	Cover	115-00500-00	[2]
16	Screw, 4-40x.187, FLHP100, SS/P, with Nylon	211-63234-06	[2]

[1] Supplied as part of GRT 10 Connector Kit P/N 011-01556-00.

[2] Supplied as part of Backshell Kit P/N 011-00950-00 (included in kit 011-01556-00).

[3] Supplied as part of Ground Adapter Kit P/N 011-01169-00 (included in kit 011-01556-00).

[4] Not supplied – must be purchased separately.

[5] Solder sleeve with pre-installed lead may be used instead of items 5 and 6.

2.5.3.2 D-Sub Connector and Mounting Hardware

Table 2-10. D-Sub Connector and Hardware

Item	Description	Garmin P/N	Notes
9-Pin Housing (Female)	D-Sub, Standard Density, Mil Crimp, 9 ckt	330-00383-09	[1], [2]
Spring-loaded Slidelock	D-Sub, Slide Lock Kit, 9/15 Pin	330-90006-00	[1]
Screw	Screw, 4-40 x .375, PHP, SS/P, Nylon	211-60234-10	[1]

[1] Supplied as part of the GRT 10 Connector Kit P/N 011-01556-00.

[2] Tabless backshell (330-00383-09) is required for use with the slidelock mount

CAUTION



When mounting the slidelock, use only the specified screws (211-60234-10). Do not attempt to use self-tapping screws, as these damage the backshell housing.

2.5.3.3 Shield Block Assembly Procedure

The parts for the connector and backshell assembly for GRT 10 installations are listed in Table 2-9 and shown in Figure 2-9.

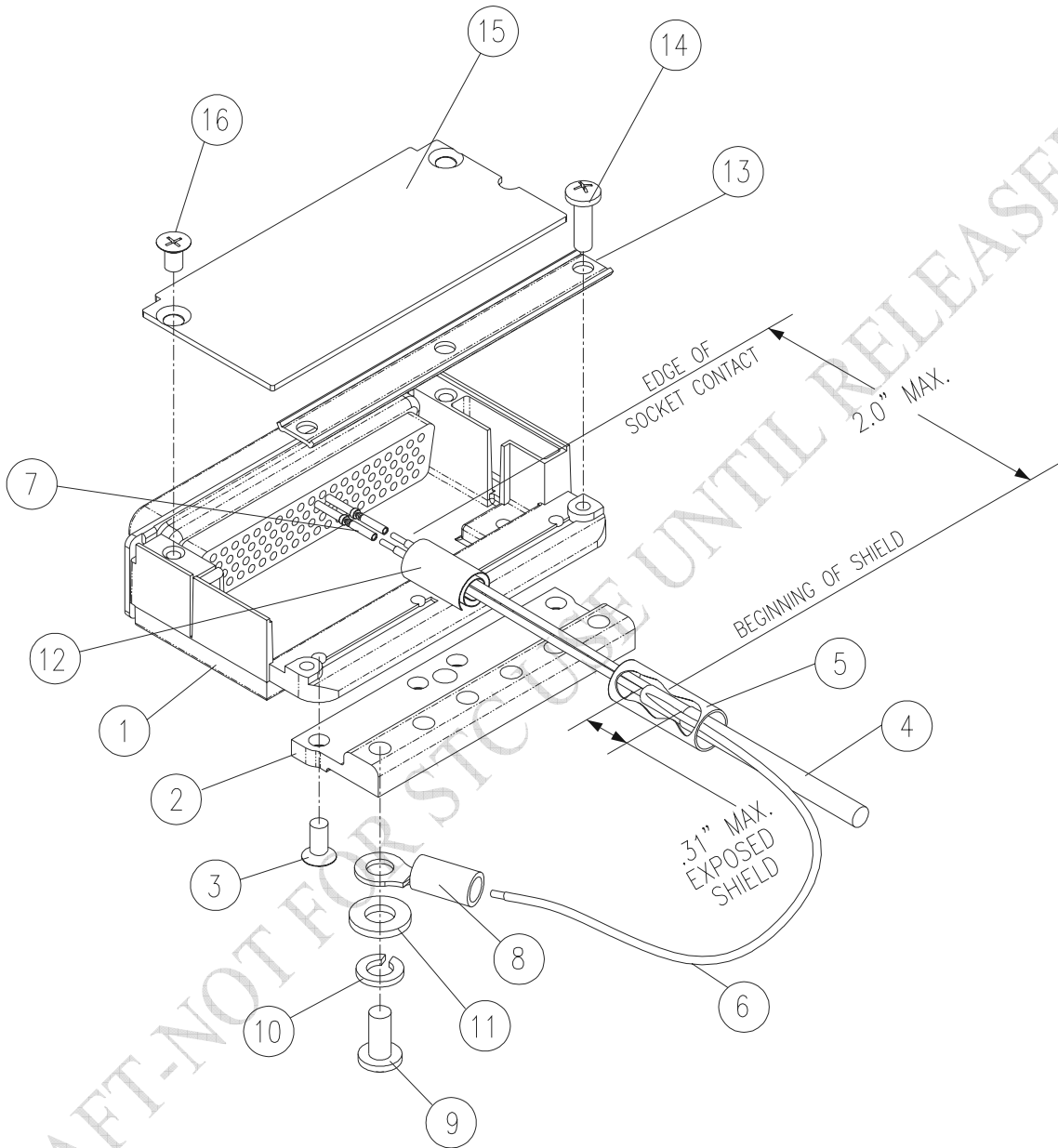

Figure 2-9. Typical Shield Block Install onto Backshell Connector Assembly

1. Attach the Shield Block (2) to the backshell (1) by inserting the flathead screws (3) through the holes on the Shield Block and threading into the tapped holes on the backshell (1). (See Figure 2-9).

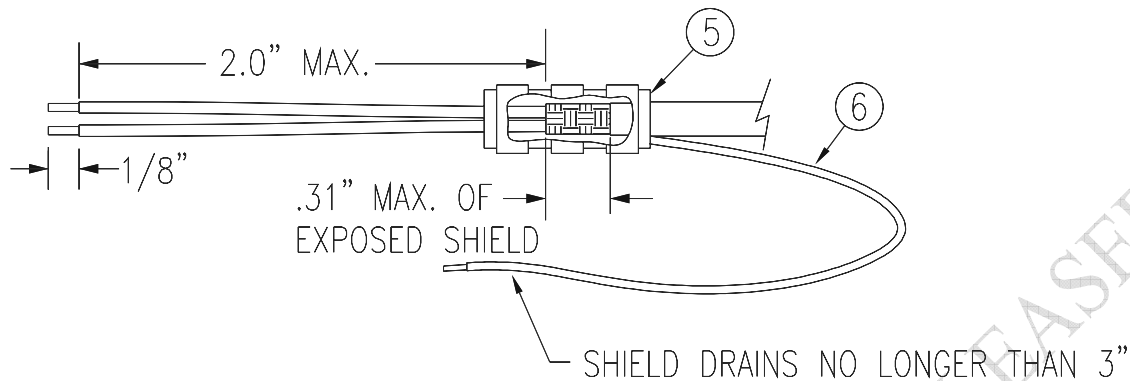

Figure 2-10. Shielded Cable Preparation

2. At the end of the shielded cable (4), strip back a 2" maximum length of the jacket to expose the braid. Remove this exposed braid. Carefully score the jacket 1/4" to 5/16" from the end and remove the jacket to leave the braid exposed.

NOTE



Solder sleeves with pre-installed shield drains may be used instead of separate shield terminators and individual wires.

3. Connect a 20 or 22 AWG wire (6) to the exposed shield of the prepared cable assembly. (See Figure 2-10). Note: AC 43.13 may be a helpful reference for termination techniques.

NOTE



Solder Sleeves with pre-installed lead: A preferred solder sleeve is the Raychem S03 Series with the thermochromic temperature indicator. These solder sleeves come with a pre-installed lead and effectively take the place of items 5 and 6. For detailed instructions on product use, refer to Raychem installation procedure.

4. Slide a shield terminator (5) onto the prepared cable assembly (4) and connect the wire (6) to the shield using a heat gun approved for use with solder sleeves. The chosen size of solder sleeve must accommodate both the number of conductors present in the cable and the wire (6) to be attached.
5. Repeat steps 2 through 4 as needed for the remaining shielded cables.

NOTE



Each tapped hole on the Shield Block (2) may accommodate only two ring terminals (8). It is preferred that a maximum of two Wires (6) be terminated per ring terminal. Two Wires per ring terminal will necessitate the use of a Ring terminal, #8, insulated, 14-16 AWG (MS25036-153). If only a single Wire is left or if only a single Wire is need for this connector a Ring terminal, #8, insulated, 18-22 AWG (MS25036-149) can accommodate this single wire. If more wires exist for the connector than two per ring terminal, it is permissible to terminate three wires per ring terminal.

6. Terminate the ring terminals to the Shield Block (2) by placing items on the Pan Head Screw (9) in the following order: Split Washer (10), Flat Washer (11), first Ring Terminal, second Ring Terminal if needed, before finally inserting the screw into the tapped holes on the Shield Block.
7. Wrap the cable bundle with Silicone Fusion Tape (12) (GPN: 249-00114-00 or a similar version) at the point where the backshell strain relief and cast housing will contact the cable bundle.

- Place the smooth side of the backshell strain relief (13) across the cable bundle and secure using the three screws (14).

WARNING



Placing the grooved side of the strain relief across the cable bundle may damage wires.

- Attach the cover (15) to the backshell (1) using two screws (16).

2.5.4 Audio Suppression

XM Audio Entertainment to crew locations may require audio suppression to comply with the STC Limitations. Determine the activation state for each horn installed in the aircraft (aircraft power signifying active high or ground signifying active low) by using one of the following methods:

- Find the horn and compare the installation with Figure D-5.
- Activate the horn per the method described in the aircraft's maintenance manual. (For the gear horn, this may require having the aircraft raised on jacks).
- With a multimeter, determine which horn contact changes state with the activation signal and if the active state is high or low.

Wire the appropriate audio suppression input (high or low) in accordance with Figure D-5.

2.5.5 Remote Discrete Switches (Optional)

If XM audio entertainment is installed in the aircraft, optional functional switches may be installed as desired even if a GRT 10 is installed. The functions of the switches must include the ability to mute the audio, adjust the volume and channels. It may be incorporated as desired depending on the installation. Figure D-1 and Figure D-2 detail the wiring for the optional discrete switches. A common aircraft ground signal may be used for each switch. It is recommended to use a rocker type switch for channel and volume control. Using a rocker type switch will prevent inadvertently raising and lowering the channel at the same time as well as the volume. An acceptable switch for this installation of the remote discrete switches is Carlingswitch P/N 62111281-0-0-N (62111231-0-0-N for the switch used for muting). Since the input signals are active-low it is permissible to use multiple switches for each function. This would allow volume and channel control to be available at each passenger station.

The GDL 69/69A's 15 preset channels (favorites) can be sequenced using the audio channel control input. On power up, the GDL 69A reads the state of the audio channel control input. When this discrete is active (low), the Channel Up and Channel Down inputs will function as Preset Up and Preset Down, respectively.

2.6 XM Antenna

For use with the GDL 69/69A, the GA 37, GA 55, GA 55A, and GA 57 antennas are an XM Satellite Radio antenna operating within a frequency range of 2332-2345 MHz for general aviation.

NOTE

Depending on specific installations, the installer may want to use a different make/model of XM Satellite Radio antenna. (An alternate antenna may be used providing it meets the minimum requirements shown in Table 1-10).



It is the installer's responsibility to ensure that their choice of antenna meets FAA certification standards according to the specific installation. This installation manual discusses only the antennas listed in Table 1-9, which are used during STC certification by Garmin. Other antennas may be acceptable but their installation is not covered by this manual and is outside the scope of the data approved in the GDL 69/69A STC.

There are several critical factors to take into consideration before installing an antenna for a satellite communications system. These factors are addressed in the following sections.

2.6.1 Antenna Mounting

For installation mounting of the XM antenna listed in Table 1-9, use Garmin GA Antenna AML STC number SA01695SE. Verify aircraft model is listed on the AML and follow limitations defined in that STC data.

2.6.2 Antenna Grounding

NOTE



Improper grounding of the antenna is typically the primary cause of reduced signal reception quality.

It is very important to have good conductivity between the coaxial shield and the ground plane. This is ensured when all the fasteners properly ground the antenna base to the skin of the aircraft. The resistance between the antenna and the skin of the aircraft should be less than 10 milliohms.

2.6.3 XM Antenna Location

As with any antenna installation, keep the following points in mind:

1. The XM Satellite signal is a line-of-sight signal. Locating antennas too close to obstructions such as the vertical stabilizer will limit the reception of the satellite signal.
2. Maintain about three feet from heater, ignition, autopilot, and other control surface actuators and motors. Maintain about five feet from fluorescent lamps, related ballast, air conditioners, blowers, strobe lights and power supplies.
3. The minimum distances to be observed when selecting an antenna location are as follows:
 - 1.25 inches from any passive (receive only) antenna such as a GPS or another XM.
 - 5 inches from a VHF active antenna such as COM or ACARS.
 - 5 inches from an active radar altimeter (4 GHz).
 - 12 inches from a UHF / Microwave transmitting antenna such as a transponder, DME, active TCAS, UAT, SATCOM, or Flitephone.
4. The XM antenna must be mounted on top of the aircraft for greatest satellite visibility. For best performance, select a location with an unobstructed view of the sky above the aircraft when in level flight. Location of communication antennas too close to the XM antenna may not only degrade the transmission through reflection, but can also absorb and re-radiate the transmission causing a condition similar to having two COM antennas located in close proximity to each other.

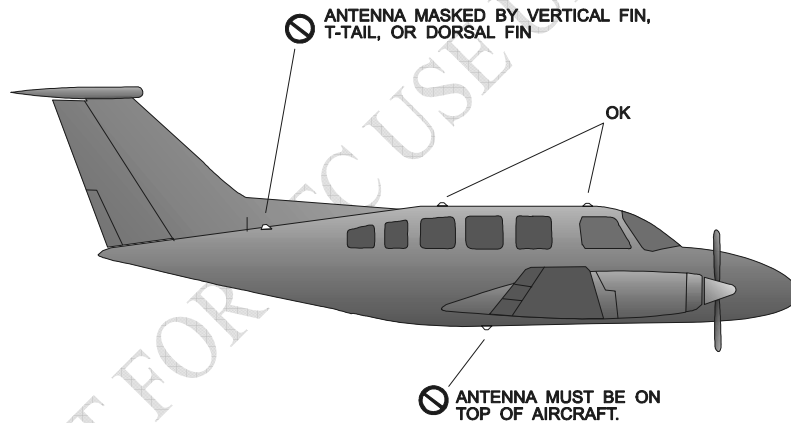
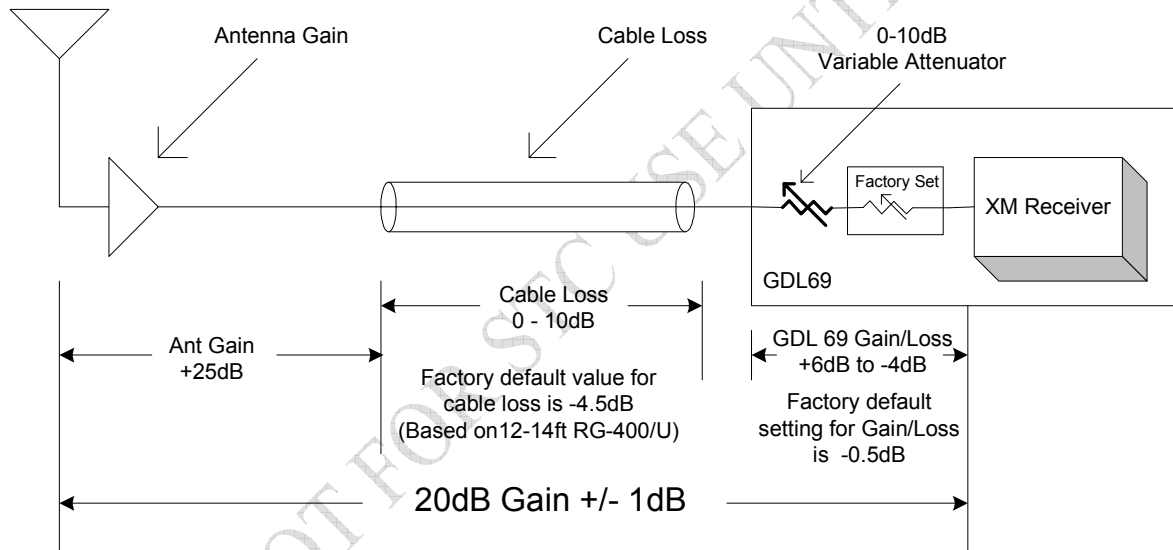

Figure 2-11. Antenna Installation Location

2.6.4 XM Radio Antenna to Receiver Signal Requirements

The XM Radio Receiver used in the GDL 69/69A has a system signal requirement of 20dB +/- 1dB gain from the input of the antenna to the input of the XM receiver internal to the GDL 69/69A. To insure the proper operation and optimum performance of the GDL 69/69A, the installation must meet the requirements specified in Table 1-10, and the installer must account for the signal gain and loss factors that exist between the antenna and the XM receiver. The gain/loss factors that need to be accounted for are shown in Figure 2-12. The GDL 69/69A has the capability to internally adjust for variances in the gain/loss factors by providing additional gain or loss within the range of +6dB to -4dB. If the GDL 69/69A gain/loss factor is outside this range, additional gain or loss must be added between the antenna and the GDL 69/69A RF input. Record the gain/loss components in Table 2-11 and in the post-installation checkout sheet located at the end of Section 4. The variable attenuation value required to attain the GDL 69/69A gain/loss component will be programmed into the configuration module during post installation checkout.

GDL69 XM Antenna to Receiver Signal Gain Requirements



Signal Gain Equation

$$20\text{dB} \pm 1\text{dB} = \text{Antenna Gain} - \text{Cable Loss} (\pm) \text{GDL 69 Internal Gain/Loss}$$

Equation Values-----Range-----

Antenna Gain = 23dB to 40dB

Cable Loss = 0.5dB to 26dB

GDL 69 Internal Gain/Loss = +6dB to -4dB (Based on Variable Attenuator setting 0dB to 10dB)

Equation using GA 55, GA 55A, GA57 Antenna with 12-16ft RG-400/U cable (Factory Default setting)
 $25\text{dB} - 4.5\text{dB} - 0.5\text{dB} = 20\text{dB}$

Figure 2-12. XM Signal Gain Requirements

Table 2-11. XM Gain/Loss Component Calculation

Antenna Gain (1)	+
Cable Loss (2) (3)	-
GDL 69/69A Gain/Loss (4) +6dB ≥ x ≥ -4dB	+/-
Total Gain Antenna/Receiver	= 20 dB

Note:

- (1) Garmin GA 37, GA 55, GA 55A, GA 57 XM antenna typical gain 25 dB. For antenna gain for other antennas, see manufacturer’s specifications.
- (2) If 12-16ft of RG-400/U cable is used, a value of 4.5dB can be used. See Section 2.6.4.1 for explanation of calculation.
- (3) If an antenna with increased gain is installed (antenna other than the Garmin antennas listed in Table 1-9), additional cable length may be required to be coiled to compensate for the required cable loss. Alternately, an external attenuator may be used to obtain the desired antenna cable loss. However, installation of the external attenuator is beyond the scope of this STC. Additional manufacturer’s data may be necessary and FAA approval may be required to cover the installation of an external attenuator.
- (4) The GDL 69/69A Gain/Loss component must be between +6dB and -4dB. If the GDL 69/69A gain/loss component is outside this range, additional gain or loss must be added between the antenna and the GDL 69/69A RF input. The factory default setting for the internal GDL 69/69A component is -0.5dB. The variable attenuation value required to attain the GDL 69/69A gain/loss component will be programmed into the configuration module during post installation checkout. See Section 2.6.4.2 for explanation of calculation.

2.6.4.1 Determining Antenna Cable Loss Value

The GDL 69/69A is factory preset with a default cable loss value of 4.5 dB, which is equivalent to 12 to 16 feet of RG-400/U cable with two properly terminated TNC connectors. If the installed antenna cable is within this length, use this value in Table 2-11. If the cable is different from the default cable, use the following formula to determine the cable loss value to use in Table 2-11.

$$\text{Loss in dB} = \frac{(\text{Length} \times \text{Loss})}{100} + (0.5 \times \#\text{Connectors})$$

Where:

- Length** – Cable length in feet
- Loss** – Specified cable loss per 100 feet at 2332-2345 MHz
- Connectors** – Number of connectors on cable

For example:

If an RG-400 coax cable is 10 feet long with 2 TNC connectors, the cable loss component is

$$\text{Loss} = \frac{(10 \times 26.1)}{100} + (0.5 \times 2) = 3.61 \text{ dB}$$

2.6.4.2 Determining GDL 69/69A Gain/Loss Component Value

The GDL 69/69A has a zero to 10dB variable attenuator that is used to balance the gain/loss component between its RF input and internal XM Receiver. The gain/loss components can be adjusted between +6dB and -4dB to balance the Antenna input to XM receiver 20dB gain requirement as specified for the XM system. The Gain/Loss component is factory preset with a default value of -0.5 dB. Using the Signal Gain Equation shown in Figure 2-9 and solving for the GDL 69/69A component the equation becomes

$$\text{GLcomp in dB} = \text{XMgain} - \text{Antenna} + \text{Cable}$$

Where:

GLcomp – GDL 69/69A Gain/Loss Component

XMgain – XM specified gain from antenna input to XM receiver input (20dB)

Antenna – Antenna Gain

Cable – Cable Loss

Example:

If the cable loss calculated in the previous example is used, the GDL 69/69A GLcomp component is:

$$\begin{aligned} \text{GLcomp} &= 20\text{dB} - 25\text{dB} + 3.61\text{dB} \\ &= -5\text{dB} + 3.61\text{dB} \\ &= -1.39\text{dB} \end{aligned}$$

The GDL 69/69A gain/loss component will be programmed into the configuration module during post installation checkout.

2.6.5 Coaxial Cable Installation

1. Choose the correct coax: RG-400/U has good characteristics for loss, size, and flexibility.

NOTE

The cable loss of the antenna cable is critical to the performance of the GDL 69/69A operation. To accommodate this, the GDL 69/69A has the ability to be configured for the amount of antenna cable loss. To reduce the need to configure the GDL 69/69A for cable loss, the GDL 69/69A is factory-preset with a cable loss of 4.5 dB, which is equivalent to 12 to 16 feet of RG-400/U with two properly terminated TNC connectors. If the cable loss is different than the default value, the cable loss must be calculated or measured and the loss value programmed into the GDL 69's configuration module. Refer to Section 4.2 for additional information on determining antenna cable loss value and how to program the configuration module.

NOTE

To avoid programming the configuration module, use a coax cable length that is within the factory default cable loss value (refer to Section 2.6.4.1). When using the default cable loss value, additional cable after routing through the aircraft may be coiled and secured as needed. Do not coil the cable tighter than a one foot diameter.

2. Trim the coaxial cable to the desired length and install TNC connectors at each end per the cabling instructions listed in Figure 2-13. For routing convenience, one end of the coaxial run can be terminated prior to installation.
3. With the GDL 69/69A receiver and antenna installed, route and clamp the coaxial cable in position. Secure cable in accordance with AC 43.13-1B, Chapter 11.

2.7 Weight and Balance

Weight and balance computation is required after the installation of the GDL 69/69A and optional GRT 10. Follow the guidelines as established in AC 43.13-1B, Chapter 10, Section 2. Make appropriate entries in the equipment list indicating items added, removed, or relocated along with the date accomplished. Include your name and certificate number in the aircraft records. Table 2-12 identifies the weight of the new GDL 69/69A and optional GRT 10 and GRC 10 equipment. Figure 1-4, Figure 1-5, and Figure 1-6 show the center of gravity.

Table 2-12. Unit Weights

Item	Weight	Notes
GDL 69 Weight	1.72 lbs (0.78 kg)	
GDL 69 and Remote Rack Weight	2.69 lbs (1.22 kg)	
GDL 69 and Modular Rack Weight	2.67 lbs (1.21 kg)	
GDL 69A Weight	1.86 lbs (0.84 kg)	
GDL 69A and Remote Rack Weight	2.83 lbs (1.29 kg)	
GDL 69A and Modular Rack Weight	2.81 lbs (1.27 kg)	
GA 37 Antenna	0.50 lbs (0.23kg)	
GA 55 Antenna	0.25 lbs (0.11 kg)	
GA 55A Antenna	0.43 lbs (0.20 kg)	
GA 57 Antenna	0.47 lbs (0.21 kg)	
GRT 10 Transceiver Weight (excluding connector kit)	0.15 lbs (0.07 kg)	
GRT 10 Transceiver Weight (including connector kit)	0.27 lbs (0.12 kg)	
GRC 10 Remote Control Weight (without batteries)	0.23 lbs (0.11 kg)	[1]
GRC 10 Remote Control Weight (with batteries)	0.34 lbs (0.15 kg)	[1]

[1] The GRC 10 is a portable unit whose weight is negligible and does not need to be included in the weight and balance computation.

2.8 Electrical Load Analysis

An electrical load analysis should be completed on each aircraft prior to installation in accordance with AC 43.13-1B, Chapter 11 and recorded on FAA Form 337. Use the following values for computation:

GDL 69

Unit Status	Max Current @ 28 VDC	Max Current @ 14 VDC
Off	0.01 A	0.01 A
On	0.28 A	0.425 A

GDL 69A

Unit Status	Max Current @ 28 VDC	Max Current @ 14 VDC
Off	0.01 A	0.01 A
On	0.35 A	0.65 A

Note: Unit OFF is defined as the unit has power but is turned off with the remote power control signal.

GRT 10 Transceiver

Unit Status	Max Current @ 28 VDC	Max Current @ 14 VDC
On	36 mA	36 mA

GRC 10 Remote Control

The GRC 10 Remote Control is a portable battery-powered unit.

NOTE



Circuits should be protected in accordance with guidelines in AC 43.13-1B, chapter 11, Section 2, Paragraph 429.

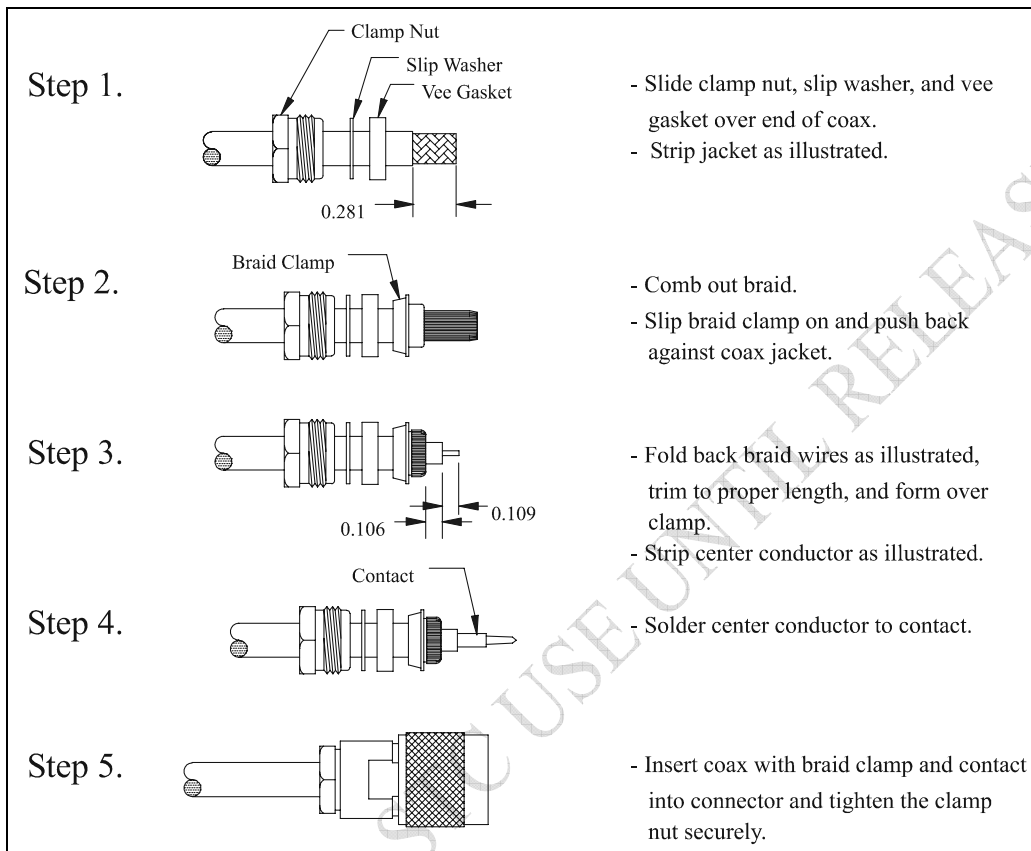

Figure 2-13. TNC Connector Installation

2.9 Cooling Air

The GDL 69/69A and optional GRT 10 do not require cooling air and do not generate an excessive amount of heat during typical operations; however the thermal characteristics of the installation should always be assessed. An undesirable thermal condition could be created due to the unit's own internal power dissipation combined with restricted ventilation, or due to heat generated by adjacent equipment. Limiting thermal build up, by means of fan or natural convection is always a good practice and recommended to increase the product life.

2.10 Installing/Inserting Unit

For final installation and assembly, refer to the outline and installation drawings shown in Figure 2-2 or Figure 2-5 of this manual. The two installation configurations available are the G1000 modular rack or remote mount. For both configurations, insert the GDL 69/69A into the rack, noting proper orientation as shown on the installation drawing in Figure 2-2 or Figure 2-5.

NOTE



The following steps are for the remote mounting rack which is illustrated in Figure 2-14. The steps are identical for the modular rack.

1. Loosen and remove the Locking Lever Handle Securing Screw (4). Then, lift up on the end of the Locking Lever Handle (1).
2. Slide the GDL 69/69A unit into the Mount Rack carefully fitting the Locking Lever Handle Cam Head (2) into the slot of the Locking Plate (3) of the Mount Rack.
3. After fully inserting the unit into the mount rack, visually note that the Cam Head (2) remains seated in the slot of the Locking Plate (3).

NOTE

When inserting the GDL 69/69A into the Remote Mount Rack, it may be possible for the Pivot Pin (2) to fit between the unit and the mount rack without going into the slot of the Locking Plate (3). If the Cam Head (2) does not seat in the slot of the Locking Plate (3), the unit will not firmly engage with the mount rack and the unit could come loose from the rack.

1. With the unit firmly engaged with the mount rack, lower the Locking Lever Handle (1). Then, insert and tighten the Locking Lever Handle Securing Screw (4) to mechanically secure the unit to the Mount Rack.

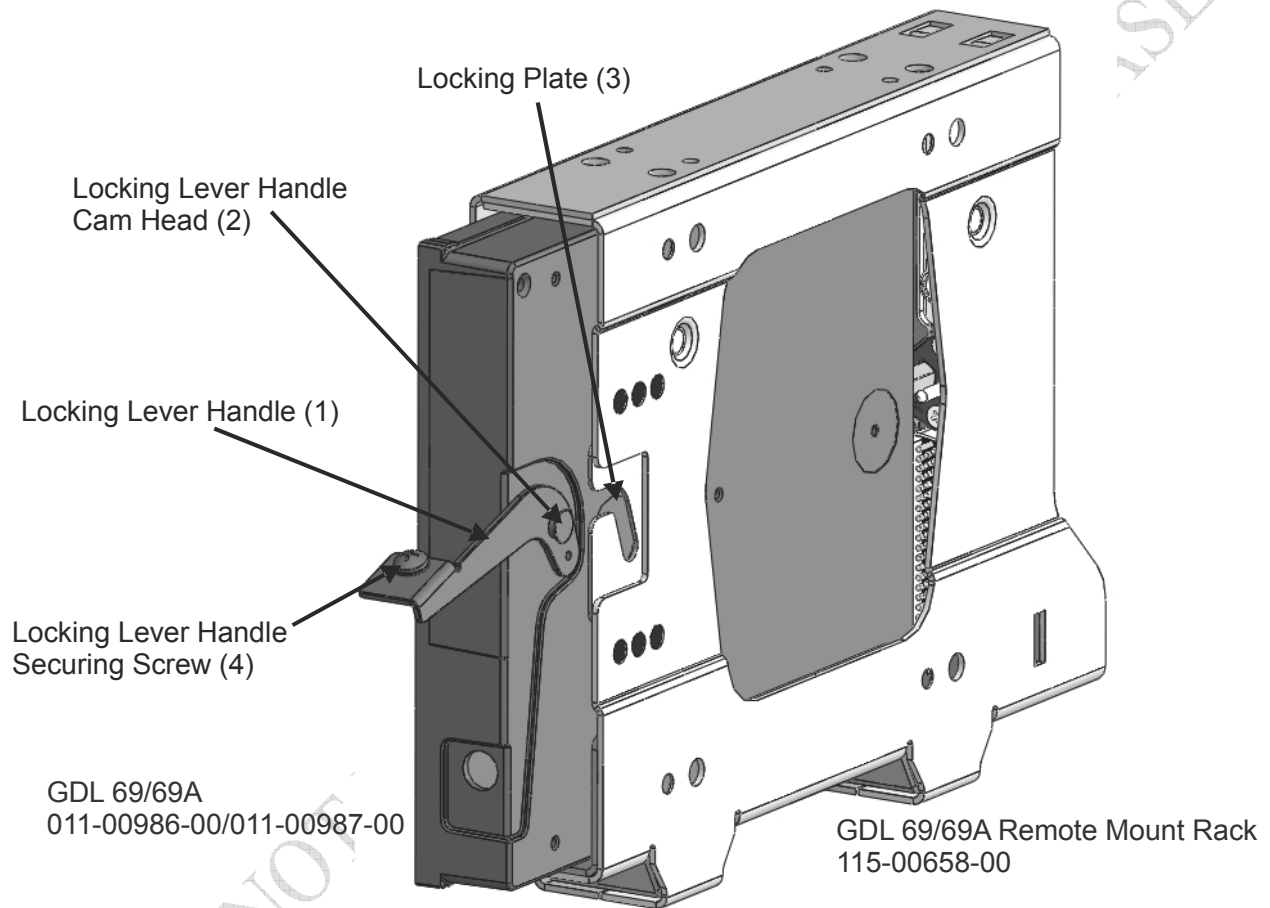

Figure 2-14. GDL 69/69A Installation

CAUTION

Do not use excessive force when inserting the GDL 69/69A into the rack. This may cause damage to occur to the connectors, unit, and/or unit rack. If heavy resistance is felt during installation, **STOP!** Remove the GDL 69/69A and identify the source of resistance. The unit is designed with a key and the back plate is designed to float in the unit rack. Check to ensure the rear plate is not bound by the connector harness.

This Page Intentionally Left Blank

DRAFT-NOT FOR STC USE UNTIL RELEASED