



A01653

Installation Instructions	2
Instructions d'installation	5
Istruzioni di installazione	8
Installationsanweisungen	11
Instrucciones de instalación	15

Garmin® and the Garmin logo are trademarks of Garmin Ltd. or its subsidiaries, registered in the USA and other countries. These trademarks may not be used without the express permission of Garmin.
NMEA® and NMEA 2000® are registered trademarks of the National Marine Electronics Association. Other trademarks and trade names are those of their respective owners.
El número de registro COFETEL/IFETEL puede ser revisado en el manual a través de la siguiente página de internet.



A01653 Series Installation Instructions

Important Safety Information

⚠ WARNING

See the *Important Safety and Product Information* guide in the product box for product warnings and other important information.

⚠ CAUTION

Always wear safety goggles, ear protection, and a dust mask when drilling, cutting, or sanding.

NOTICE

When drilling or cutting, always check what is on the opposite side of the surface.

Registering Your Device

Help us better support you by completing our online registration today.

- Go to <http://my.garmin.com>.
- Keep the original sales receipt, or a photocopy, in a safe place.

Contacting Garmin® Product Support

- Go to www.garmin.com/support for in-country support information.
- In the USA, call 913-397-8200 or 1-800-800-1020.
- In the UK, call 0808 238 0000.
- In Europe, call +44 (0) 870 850 1241.

Mounting Considerations

NOTICE

This device should be mounted in a location that is not exposed to extreme temperatures or conditions. The temperature range for this device is listed in the product specifications. Extended exposure to temperatures exceeding the specified temperature range, in storage or operating conditions, may cause device failure. Extreme-temperature-induced damage and related consequences are not covered by the warranty.

When selecting a mounting location, you should observe these considerations.

- The location should provide optimal viewing as you operate your boat.
- The location should allow for easy access to all device interfaces, such as the keypad, touchscreen, and card reader, if applicable.
- The location must be strong enough to support the weight of the device and protect it from excessive vibration or shock.
- To avoid interference with a magnetic compass, the device should not be installed closer to a compass than the compass-safe distance value listed in the product specifications.
- The location must allow room for the routing and connection of all cables.

Antenna Mounting and EME Exposure

⚠ WARNING

Radio operators with cardiac pacemakers, life-support machines, or electrical medical equipment should not be exposed to excessive radio-frequency (RF) fields, because the RF field may interfere with the function of their medical equipment.

⚠ CAUTION

This device generates and radiates radio frequency (RF) electromagnetic energy (EME). Failure to observe these guidelines may expose people to RF radiation absorption exceeding the maximum permissible exposure (MPE).

Garmin declares a MPE radius of 2.48 m (97 in.) for this system, which was determined using 25 W output to an omni-directional, 6 dBi gain antenna. The antenna should be installed to maintain a distance of 2.48 m (97 in.) between the antenna and all people.

Bail Mounting the Device

NOTICE

If you are mounting the bracket on fiberglass with screws, it is recommended to use a countersink bit to drill a clearance counterbore through only the top

gel-coat layer. This will help to avoid cracking in the gel-coat layer when the screws are tightened.

Stainless-steel screws may bind when screwed into fiberglass and overtightened. It is recommended to apply an anti-seize lubricant on the screws before installing them.

You can use the included bracket to bail mount the device on a flat surface.

- 1 Using the bail-mount bracket ① as a template, mark the pilot holes.

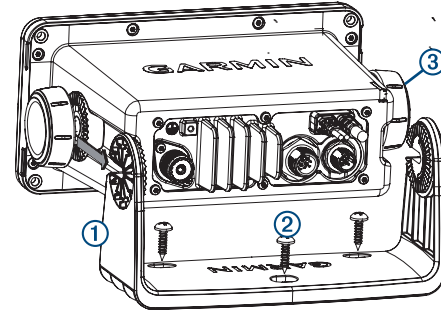

- 2 Using a 3.5 mm ($\frac{9}{64}$ in.) drill bit, drill the pilot holes.
- 3 Using the included screws ②, secure the bail-mount bracket to the mounting surface.
- 4 Install the bail-mount knobs ③ on the sides of the device.
- 5 Place the device in the bail-mount bracket and tighten the bail-mount knobs.

Flush Mounting the Device

NOTICE

Be careful when cutting the hole to flush mount the device. There is only a small amount of clearance between the case and the mounting holes, and cutting the hole too large could compromise the stability of the device after it is mounted.

If you are mounting the bracket on fiberglass with screws, it is recommended to use a countersink bit to drill a clearance counterbore through only the top gel-coat layer. This will help to avoid cracking in the gel-coat layer when the screws are tightened.

Stainless-steel screws may bind when screwed into fiberglass and overtightened. It is recommended to apply an anti-seize lubricant on the screws before installing them.

The included template and hardware can be used to mount the device in your dashboard.

- 1 Trim the template and make sure it fits in the location where you want to mount the device.
- 2 Using a 9.5 mm ($\frac{3}{8}$ in.) drill bit, drill one or more of the holes inside the corners of the solid line on the template to prepare the mounting surface for cutting.
- 3 Using a jigsaw or rotary tool, cut the mounting surface along the inside of the solid line indicated on the template.
- 4 Place the device in the cutout to test the fit.
- 5 If necessary, use a file and sandpaper to refine the size of the cutout.
- 6 After the device fits correctly in the cutout, ensure the mounting holes on the device line up with the pilot holes on the template.
- 7 If the mounting holes on the device do not line up, mark the new pilot-hole locations.
- 8 Using a 3.5 mm ($\frac{9}{64}$ in.) drill bit, drill the pilot holes.
- 9 Remove the template from the mounting surface.
- 10 If you will not have access to the back of the device after you mount it, connect all necessary cables to the device before placing it into the cutout.
- 11 If necessary, cover unused connectors with the attached weather caps to prevent corrosion of the metal contacts.
- 12 Install the foam gasket ① on the back of the device.

The pieces of the rubber gasket have adhesive on the back. Make sure you remove the protective liner before installing them on the device.

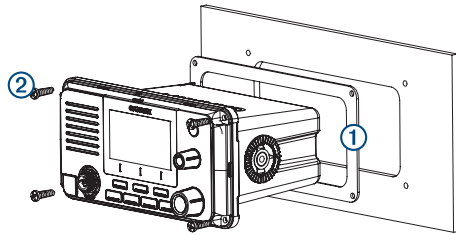

- 13 Place the device in the cutout.
- 14 Secure the device to the mounting surface using the included screws ②.
- 15 Install the decorative bezel by snapping it in place around the edges of the device.

Mounting the Microphone Hanger

NOTICE

If you are mounting the bracket on fiberglass with screws, it is recommended to use a countersink bit to drill a clearance counterbore through only the top gel-coat layer. This will help to avoid cracking in the gel-coat layer when the screws are tightened.

Stainless-steel screws may bind when screwed into fiberglass and overtightened. It is recommended to apply an anti-seize lubricant on the screws before installing them.

You can mount the microphone hanger in a convenient location near the radio.

- 1 Select a mounting location for the microphone within reach of the microphone cable.
- 2 Using the microphone hanger ① as a template, mark the pilot holes.

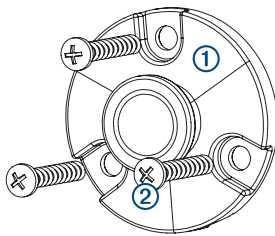

- 3 Drill the mounting holes using a 3 mm (1/8 in.) drill bit.
- 4 Secure the microphone hanger to the mounting surface using the included screws ②.

Connection Considerations

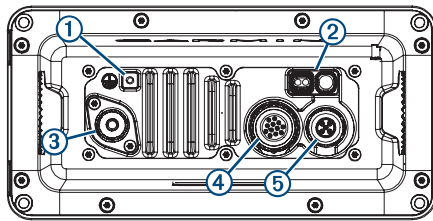

Item	Description	Notes
①	Ground connection	You can use the included grounding screw to connect the device chassis to water ground, if needed (<i>Additional Grounding Considerations</i> , page 3).
②	Power, NMEA® 0183, and speaker wiring harnesses	You must connect the device to a 12 Vdc power source (<i>Connecting the Wiring Harness to Power</i> , page 3). You can connect this device to a NMEA 0183 device using this wiring harness to share DSC and GPS information (optional) (<i>NMEA 0183 Device Connections</i> , page 4). You can connect this device to a hailer horn using this wiring harness (optional) (<i>Connecting to a Hailer Horn or PA Speaker</i> , page 4). You can connect this device to an external speaker using this wiring harness (optional) (<i>Connecting to an External Speaker</i> , page 4).

Item	Description	Notes
③	VHF antenna connection	You must connect the device to a VHF antenna (sold separately) (<i>Connecting a VHF Antenna</i> , page 3).
⑤	NMEA 2000® connector	You can connect this device to a NMEA 2000 network on your boat to share DSC and GPS information (optional) (<i>NMEA 2000 Device Connections</i> , page 3).

Connecting the Wiring Harness to Power

- 1 Route the wiring harness to the power source and to the device.
- 2 Connect the red wire to the positive (+) battery terminal, and connect the black wire to the negative (-) battery terminal.

Additional Grounding Considerations

This device should not need any additional chassis grounding in most installation situations. If interference is experienced, the grounding screw on the housing can be used to connect the device to the water ground of the boat to help avoid the interference.

Connecting a VHF Antenna

- 1 Mount the VHF antenna (sold separately) according to the installation instructions provided with the antenna.
- 2 Connect the VHF antenna to the antenna port on the back of the radio.

NMEA 2000 Device Connections

NOTICE

If you are connecting this device to an existing NMEA 2000 network, the NMEA 2000 network should already be connected to power. Do not connect the NMEA 2000 power cable to an existing NMEA 2000 network, because only one power source should be connected to a NMEA 2000 network.

If you are connecting this device to an existing NMEA 2000 network or engine network by another manufacturer, you should install a NMEA 2000 Power Isolator (010-11580-00) between the existing network and the Garmin devices.

If you are installing a NMEA 2000 power cable, you must connect it to the boat ignition switch or through another in-line switch. NMEA 2000 devices will drain your battery if the NMEA 2000 power cable is connected to the battery directly.

To connect this device to your existing NMEA 2000 network, you must purchase a NMEA 2000 cable and connector.

If you are unfamiliar with NMEA 2000, you should read the "NMEA 2000 Network Fundamentals" chapter of the *Technical Reference for NMEA 2000*

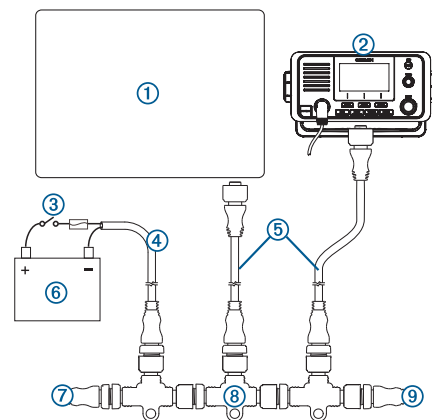

Item	Description
①	Compatible NMEA 2000 chartplotter or other device
②	A01653 device
③	Ignition or in-line switch
④	NMEA 2000 power cable
⑤	NMEA 2000 drop cable
⑥	12 Vdc power source

Item	Description
⑦	NMEA 2000 terminator or backbone cable
⑧	NMEA 2000 T-connector
⑨	NMEA 2000 terminator or backbone cable

NMEA 0183 Device Connections

This diagram illustrates two-way connections for both sending and receiving data. You can also use this diagram for one-way communication. To receive information from a NMEA 0183 device on this device, refer to items ①, ②, ④, and ⑤ in the second table. To transmit information to a NMEA 0183 device from this device, refer to items ①, ②, ⑥, and ⑦ in the second table.

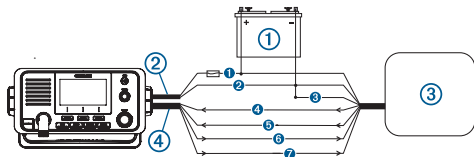

Item	Description
①	Power source
②	Power cable
③	NMEA 0183 device
④	NMEA 0183 cable

Item	Garmin Wire Function	Garmin Wire Color	NMEA 0183 Device Wire Function
①	Power	Red	Power
②	Power ground	Black	Power ground
③	Not applicable	Not applicable	Data ground (if applicable)
④	RxA (+)	Purple	TxA (+)
⑤	RxB (-)	Gray	TxB (-)
⑥	TxA (+)	Blue	RxA (+)
⑦	TxB (-)	Brown	RxB (-)

Connecting to a Hailer Horn or PA Speaker

You can connect the radio to a hailer horn or public address (PA) speaker (not included) to use the microphone or the handset to make announcements.

- If necessary, mount the hailer horn or PA speaker according to the installation instructions provided with the device.

NOTE: To avoid feedback, you should mount the hailer horn or PA speaker at least 3 m (10 ft) away from, and facing away from, the microphone or handset.

- Route or extend the wire from the hailer horn or PA speaker to the radio.
- Connect the white wire on the radio wiring harness to the positive (+) wire from the hailer horn or PA speaker.
- Connect the green wire on the radio wiring harness to the negative (-) wire from the hailer horn or PA speaker.
- Cover the connections with a waterproof tape or heat-shrink tubing.

Connecting to an External Speaker

You can connect the radio to an external speaker (not included) to hear the radio at a remote location.

- If necessary, mount the speaker according to the installation instructions provided with the device.
- Route or extend the wire from the speaker to the radio.
- Connect the red wire on the radio wiring harness to the positive (+) wire from the speaker.
- Connect the black wire on the radio wiring harness to the negative (-) wire from the speaker.
- Cover the connections with a waterproof tape or heat-shrink tubing.

Appendix

Specifications

Specification	Measurement
Dimensions (H x W x D)	A01653: 8.5 x 17 x 14.6 cm (3.35 x 6.7 x 5.75 in.) A01653: 9.8 x 19.7 x 14.9 cm (3.86 x 7.76 x 5.78 in.)
Weight	A01653 (with microphone): 1.241 kg (43.77 oz.) A01653 (without microphone): 1.212 kg (42.75 oz.) A01653 microphone: 0.248 kg (8.75 oz.)
Temperature range	Operating: From -15° to 70°C (from 5° to 158°F) Storage: From -20° to 70°C (from -4° to 158°F)
Compass-safe distance	A01653: 70 cm (27.6 in.) A01653: 75 cm (29.5 in.)
Water rating*	IEC 605290 IPX7
Antenna connector	S0-239 (50 Ω)
Operating voltage	12.0 Vdc
Current draw	Standby: 350 mA Receive: 600 mA Transmit: From 2.0 A to 6.0 A (from 1 W to 25 W)
Maximum antenna gain	6 dBi
Antenna port impedance	50 Ω
Audio output power	Internal speaker: 1 W (with 4 Ω at 10% distortion) External speaker (optional): 4 W (4 Ω/max)
Hailer output power	20 W at 4 Ω
External speaker impedance	4 Ω
Hailer horn impedance	4 Ω

NOTICE

The device is water resistant to IEC Standard 60529 IPX7. It can withstand accidental immersion in 1 meter of water for 30 minutes. Prolonged submersion can cause damage to the device. After submersion, be certain to wipe dry and air dry the device before using or charging.

NMEA 2000 PGN Information

Receive	Transmit
059392	ISO acknowledgment
059904	ISO request
060928	ISO address claim
126208	NMEA request/command/ack
126208	NMEA request/command/ack
126464	PGN list
129026	COG/SOG, rapid update
126996	Product information
129029	GNSS position data
129799	Radio frequency/mode/power
129808	DSC call information

Transmit (AIS models only)

120938	Class A position report
120939	Class B position report
120940	Class B extended position report
129793	AIS UTC and date report
129794	AIS class A static and voyage related data
129798	AIS SAR aircraft position report
129801	AIS address safety message
129802	AIS broadcast safety message
129809	AIS class B static data part A
129810	AIS class B static data part B
129041	AtoN position report

NMEA 0183 IN Sentences Supported

Sentence	Definition
GGA	Global positioning system fix data
GLL	Geographic position (latitude/longitude)
GNS	GNSS fix data

Sentence	Definition
RMA	Recommended minimum specific Loran-C data
RMB	Recommended minimum navigation information
RMC	Recommended minimum specific GNSS data

NMEA 0183 OUT Sentences Supported

Sentence	Definition
DSC	DSC information
DSE	Expanded DSC

VHF séries 110/210 AIS Instructions d'installation

Informations importantes relatives à la sécurité

⚠ AVERTISSEMENT

Consultez le guide *Informations importantes sur le produit et la sécurité* inclus dans l'emballage du produit pour prendre connaissance des avertissements et autres informations sur le produit.

⚠ ATTENTION

Portez toujours des lunettes de protection, un équipement antibruit et un masque anti-poussière lorsque vous percez, coupez ou poncez.

AVIS

Lorsque vous percez ou coupez, commencez toujours par vérifier la nature de la face opposée de l'élément.

Enregistrement de l'appareil

Aidez-nous à mieux vous servir en remplissant dès aujourd'hui notre formulaire d'enregistrement en ligne.

- Rendez-vous sur <http://my.garmin.com>.
- Conservez en lieu sûr l'original de la facture ou une photocopie.

Contacteur l'assistance produit Garmin

- Rendez-vous sur le site www.garmin.com/support pour obtenir une assistance par pays.
- Aux Etats-Unis, appelez le 913-397-8200 ou le 1-800-800-1020.
- Au Royaume-Uni, appelez le 0808 238 0000.
- En Europe, appelez le +44 (0) 870 850 1241.

Considérations relatives au montage

AVIS

Installez cet appareil à un emplacement qui n'est pas exposé à des températures ou des conditions extrêmes. La plage de températures pour cet appareil est indiquée dans les caractéristiques techniques du produit. Une exposition prolongée à des températures dépassant la plage de températures spécifiée, pendant le stockage ou en cours de fonctionnement, peut provoquer une panne de l'appareil. Les dommages dus aux températures extrêmes et leurs conséquences ne sont pas couverts par la garantie.

Lorsque vous sélectionnez un emplacement de montage, tenez compte des considérations suivantes.

- L'emplacement de montage doit offrir une visibilité optimale en cours de navigation.
- L'emplacement doit également permettre un accès aisé à toutes les interfaces de l'appareil (clavier, écran tactile et lecteur de carte, le cas échéant).
- L'emplacement doit être suffisamment résistant pour supporter le poids de l'appareil et le protéger des vibrations ou des chocs excessifs.
- Pour éviter toute interférence avec un compas magnétique, l'appareil doit être installé à la distance de sécurité au compas indiquée dans les caractéristiques techniques du produit.
- L'emplacement doit permettre la connexion et l'acheminement de tous les câbles.

Montage de l'antenne et exposition à l'énergie électromagnétique

⚠ AVERTISSEMENT

Les opérateurs radio portant un stimulateur cardiaque ou un équipement électrique médical indispensable au maintien en vie ne doivent pas s'exposer de manière excessive aux champs électromagnétiques, car ces champs peuvent perturber le bon fonctionnement de leur équipement médical.

⚠ ATTENTION

Cet appareil génère et émet de l'énergie électromagnétique sous forme de fréquences radio (RF). Le non-respect de ces directives peut exposer les personnes à un rayonnement RF dont le niveau dépasse le maximum autorisé.

Garmin annonce un rayon EMP (exposition maximale permise) de 3,14 m (123 po) pour ce système, déterminé pour une puissance d'émission de 25 W avec une antenne omnidirectionnelle d'une sensibilité de 6 dBi. Installez l'antenne de façon à ce qu'elle se trouve toujours à au moins 3,14m (123 po) des personnes.

Montage sur étrier de l'appareil

AVIS

Si vous montez le support de montage sur de la fibre de verre avec des vis, nous vous recommandons d'utiliser un foret de fraisage pour percer un trou à fond plat à travers le revêtement de la couche supérieure. Cela vous permettra d'éviter de fissurer le revêtement au moment du serrage des vis.

Les vis en acier inoxydable risquent de se gripper lorsqu'elles sont vissées dans la fibre de verre et qu'elles sont serrées outre mesure. Il est conseillé d'appliquer un lubrifiant antigrippant sur chaque vis avant installation.

Vous pouvez utiliser le support de fixation fourni pour monter l'appareil sur un support plat.

- 1 En utilisant l'étrier de fixation ① comme modèle, marquez les trous d'implantation.

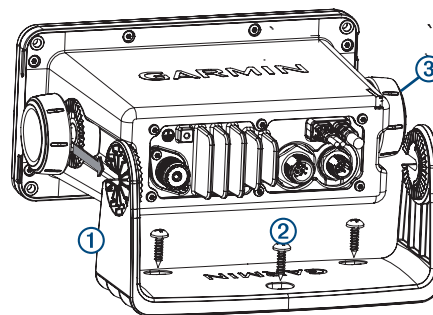

- 2 A l'aide d'un foret de 3,5 mm (9/64 po), percez les trous d'implantation.
- 3 A l'aide des vis fournies ②, fixez l'étrier sur la surface de montage.
- 4 Installez les vis de montage sur étrier ③ sur les côtés de l'appareil.
- 5 Placez l'appareil dans le support de fixation sur étrier et fixez les vis de montage sur étrier.

Montage encastré de l'appareil

AVIS

Faites attention lorsque vous percez le trou pour encastrer l'appareil. Le dégagement entre le boîtier et les trous de fixation est très réduit et en perçant un trou trop grand, vous risquez de compromettre la stabilité de l'appareil après son installation.

Si vous montez le support de montage sur de la fibre de verre avec des vis, nous vous recommandons d'utiliser un foret de fraisage pour percer un trou à fond plat à travers le revêtement de la couche supérieure. Cela vous permettra d'éviter de fissurer le revêtement au moment du serrage des vis.

Les vis en acier inoxydable risquent de se gripper lorsqu'elles sont vissées dans la fibre de verre et qu'elles sont serrées outre mesure. Il est conseillé d'appliquer un lubrifiant antigrippant sur chaque vis avant installation.

Vous pouvez utiliser le modèle et le matériel fournis pour encastrer l'appareil dans le tableau de bord.

- 1 Découpez le modèle et assurez-vous qu'il est adapté à l'emplacement de montage de l'appareil.

Important Safety and Product Information 2
Informations importantes sur le produit et la sécurité 3



Important Safety and Product Information

WARNING

Failure to heed the following warnings could result in an accident or collision resulting in death or serious injury.

Battery Warnings

The device uses an internal, non-user-replaceable battery for various purposes, such as the real-time clock.

If these guidelines are not followed, batteries may experience a shortened life span or may present a risk of damage to the device, fire, chemical burn, electrolyte leak, and/or injury.

- Do not remove or attempt to remove the non-user-replaceable battery.

Marine Operation Warnings

- **You are responsible for the safe and prudent operation of your vessel.** This device is a tool that will enhance your capability to operate your vessel. This device does not relieve you from the responsibility of safely operating your vessel. Avoid navigational hazards and never leave the helm unattended.
- Use this device only as a navigational aid. Do not attempt to use the device for any purpose requiring precise measurement of direction, distance, location, or topography.
- Always be prepared to promptly regain control of the vessel. Use caution near hazards in the water, such as docks, pilings and other vessels.
- If the device has navigating capabilities, when navigating, carefully compare information displayed on the device to all available navigation sources, including information from visual sightings, local waterway rules and restrictions, and maps. For safety, always resolve any discrepancies or questions before continuing navigation.

FCC Warnings

Exposure to Radio Frequency Signals—Your device is a radio transmitter and receiver. When it is on, it receives and also sends out radio frequency (RF) signals.

Antenna Care—Use only the supplied antenna or a recommended antenna accessory. Unauthorized antennas, modifications, or attachments could damage the radio and may violate FCC regulations. Warning: Do not use any radio that has a damaged antenna, because if it comes into contact with your skin, a minor burn can result.

Electronic Devices—Most modern electronic equipment is shielded from RF signals. However, certain equipment may not be shielded against the RF signals from your wireless radio.

Pacemakers—The Health Industry Manufacturers Association (HIMA) and Wireless Technology Research recommend that a minimum separation of six inches (6") be maintained between a handheld wireless radio and a pacemaker to avoid potential interference with the pacemaker. Persons with pacemakers should ALWAYS keep the radio more than six inches from their pacemaker when the radio is turned on, should not carry the radio in a breast pocket, and should turn the radio off immediately if you have any reason to suspect that interference is taking place.

Hearing Aids—Some digital wireless radios may interfere with some hearing aids. In the event of such interference, you may want to consult your hearing aid manufacturer to discuss alternatives.

Posted Facilities—Turn your radio OFF in any facility where posted notices so require.

Vehicles—RF signals may affect improperly installed or inadequately shielded electronic systems in motor vehicles. Check with the manufacturer or its representative regarding your vehicle. You should also consult the manufacturer of any equipment that has been added to your vehicle.

Commercial Aircraft—Many commercial airlines prohibit the use of radios on board. Switch OFF your radio before boarding an aircraft or check the airline rules.

Potentially Explosive Atmospheres—Turn your radio OFF and do not remove your battery when you are in any area with a potentially explosive atmosphere. Obey all signs and instructions. Sparks from your battery in such areas could cause an explosion or fire resulting in bodily injury or even death.

NOTICE

Failure to heed the following notice could result in personal or property damage, or negatively impact the device functionality.

Battery Notices

- Do not immerse the device or batteries in water or other liquids.
- Do not leave the device exposed to a heat source or in a high-temperature location, such as in the sun in an unattended vehicle. To prevent the possibility of damage, remove the device from the vehicle or store it out of direct sunlight, such as in the glove box.
- Do not operate the device outside of the temperature ranges specified in the printed manual in the product packaging.

- When storing the device for an extended time period, store within the temperature ranges specified in the printed manual in the product packaging.
- Contact your local waste disposal department to dispose of the device/batteries in accordance with applicable local laws and regulations.

Product Environmental Programs

Information about the Garmin® product recycling program and WEEE, RoHS, REACH, and other compliance programs can be found at www.garmin.com/aboutGarmin/environment.

Radio Frequency Radiation Exposure

This device is a mobile transmitter and receiver that uses an internal antenna to send and receive low levels of radio frequency (RF) energy for data communications. The device emits RF energy below the published limits when operating in its maximum output power mode and when used with Garmin authorized accessories. To comply with RF exposure compliance requirements, the device should be installed and used with the separation distance as described in the printed manual. The device should not be used in other configurations. This device must not be co-located or operated in conjunction with any other transmitter or antenna.

VHF Radio Information

All users are responsible for observing the regulations of their government and the regulations of foreign governments. Breaches of such regulations are subject to severe penalties. The transmitting frequencies in your radio are reserved for maritime use; any frequency you use for transmission must be specifically included on your ship's license. A special license is required to operate from land; this includes when your boat is in a trailer. The use of ATIS is prohibited outside the European inland waterways covered by the Basel Agreement.

Licensing Requirements

Many countries and administrations require a ship radio license and require the user to be in possession of a suitable radio operator license before transmitting equipment can be used for maritime communication. Contact your local administration for details.

FCC Compliance

This device complies with FCC Rules and RF exposure limits with the minimum 2.48m and maximum antenna gain 6dBi .

This product does not contain any user-serviceable parts. Repairs should only be made by an authorized Garmin service center. Unauthorized repairs or modifications could result in permanent damage to the equipment, and void your warranty and your authority to operate this device under Part 15 regulations.

Innovation, Science and Economic Development Canada Compliance

This device complies with Innovation, Science and Economic Development Canada RSS standard(s) and RF exposure limits with the minimum 2.48m and maximum antenna gain 6dBi .

Declaration of Conformity

Hereby, Garmin declares that this product is in compliance with the essential requirements and other relevant provisions of Directive 1999/5/EC. To view the full Declaration of Conformity, go to www.garmin.com/compliance.

Software License Agreement

BY USING THE DEVICE, YOU AGREE TO BE BOUND BY THE TERMS AND CONDITIONS OF THE FOLLOWING SOFTWARE LICENSE AGREEMENT. PLEASE READ THIS AGREEMENT CAREFULLY.

NOTICE:

This device is intended for use in occupational/controlled conditions, where users have full knowledge of their exposure and can exercise control over their exposure to meet FCC limits. This device is NOT authorized for general population, consumer, or any other use.

Garmin Ltd. and its subsidiaries ("Garmin") grant you a limited license to use the software embedded in this device (the "Software") in binary executable form in the normal operation of the product. Title, ownership rights, and intellectual property rights in and to the Software remain in Garmin and/or its third-party providers.

You acknowledge that the Software is the property of Garmin and/or its third-party providers and is protected under the United States of America copyright laws and international copyright treaties. You further acknowledge that the structure, organization, and code of the Software, for which source code is not provided, are valuable trade secrets of Garmin and/or its third-party providers and that the Software in source code form remains a valuable trade secret of Garmin and/or its third-party providers. You agree not to decompile, disassemble, modify, reverse assemble, reverse engineer, or reduce to human readable form the Software or any part thereof or create any derivative works based on the Software. You agree not to export or re-export the Software to any country in violation of the export control laws of the United States of America or the export control laws of any other applicable country.

Limited Warranty

Non-aviation products are warranted to be free from defects in materials or workmanship for one year from the date of purchase. Within this period, Garmin will, at its sole option, repair or replace any components that fail in normal use. Such repairs or replacement will be made at no charge to the customer for parts or labor, provided that the customer shall be responsible for any transportation cost. This Limited Warranty does not apply to: (i) cosmetic damage, such as scratches, nicks and dents; (ii) consumable parts, such as batteries, unless product damage has occurred due to a defect in materials or workmanship; (iii) damage caused by accident, abuse, misuse, water, flood, fire, or other acts of nature or external causes; (iv) damage caused by service performed by anyone who is not an authorized service provider of Garmin; (v) damage to a product that has been modified or altered without the written permission of Garmin; or (vi) damage to a product that has been connected to power and/or data cables that are not supplied by Garmin. In addition, Garmin reserves the right to refuse warranty claims against products or services that are obtained and/or used in contravention of the laws of any country.

This product is intended to be used only as a travel aid and must not be used for any purpose requiring precise measurement of direction, distance, location or topography. Garmin makes no warranty as to the accuracy or completeness of map data. Repairs have a 90 day warranty. If the unit sent in is still under its original warranty, then the new warranty is 90 days or to the end of the original 1 year warranty, depending upon which is longer.

This Limited Warranty also does not apply to, and Garmin is not responsible for, any degradation in the performance of any Garmin navigation product resulting from its use in proximity to any handset or other device that utilizes a terrestrial broadband network operating on frequencies that are close to the frequencies used by any Global Navigation Satellite System (GNSS) such as the Global Positioning Service (GPS). Use of such devices may impair reception of GNSS signals. TO THE MAXIMUM EXTENT PERMITTED BY APPLICABLE LAW, THE WARRANTIES AND REMEDIES CONTAINED IN THIS LIMITED WARRANTY ARE EXCLUSIVE AND IN LIEU OF, AND GARMIN EXPRESSLY DISCLAIMS, ALL OTHER WARRANTIES AND REMEDIES, WHETHER EXPRESS, IMPLIED, STATUTORY, OR OTHERWISE, INCLUDING WITHOUT LIMITATION ANY IMPLIED WARRANTY OF MERCHANTABILITY OR FITNESS FOR A PARTICULAR PURPOSE, STATUTORY REMEDY OR OTHERWISE. THIS LIMITED WARRANTY GIVES YOU SPECIFIC LEGAL RIGHTS, AND YOU MAY HAVE OTHER LEGAL RIGHTS WHICH VARY FROM STATE TO STATE. IF IMPLIED WARRANTIES CANNOT BE DISCLAIMED, THEN SUCH WARRANTIES ARE LIMITED IN DURATION TO THE DURATION OF THIS LIMITED WARRANTY. SOME STATES DO NOT ALLOW LIMITATIONS ON HOW LONG AN IMPLIED WARRANTY LASTS, SO THE ABOVE LIMITATION MAY NOT APPLY TO YOU.

IN NO EVENT SHALL GARMIN BE LIABLE IN A CLAIM FOR BREACH OF WARRANTY FOR ANY INCIDENTAL, SPECIAL, INDIRECT, OR CONSEQUENTIAL DAMAGES, WHETHER RESULTING FROM THE USE, MISUSE, OR INABILITY TO USE THIS PRODUCT OR FROM DEFECTS IN THE PRODUCT. SOME STATES DO NOT ALLOW THE EXCLUSION OF INCIDENTAL OR CONSEQUENTIAL DAMAGES, SO THE ABOVE LIMITATIONS MAY NOT APPLY TO YOU.

Garmin retains the exclusive right to repair or replace (with a new or newly-overhauled replacement product) the device or software or offer a full refund of the purchase price at its sole discretion. SUCH REMEDY SHALL BE YOUR SOLE AND EXCLUSIVE REMEDY FOR ANY BREACH OF WARRANTY.

To obtain warranty service, contact your local Garmin authorized dealer or call Garmin Product Support for shipping instructions and an RMA tracking number. Securely pack the device and a copy of the original sales receipt, which is required as the proof of purchase for warranty repairs. Write the tracking number clearly on the outside of the package. Send the device, freight charges prepaid, to the Garmin warranty service station provided to you. Go to www.garmin.com/support form more information about contacting Garmin Product Support for warranty service. If you bought your device in the United States, you can also call 1-800-800-1020.

Online Auction Purchases: Products purchased through online auctions are not eligible for rebates or other special offers from Garmin warranty coverage. Online auction confirmations are not accepted for warranty verification. To obtain warranty

service, an original or copy of the sales receipt from the original retailer is required. Garmin will not replace missing components from any package purchased through an online auction.

International Purchases: A separate warranty may be provided by international distributors for devices purchased outside the United States depending on the country. If applicable, this warranty is provided by the local in-country distributor and this distributor provides local service for your device. Distributor warranties are only valid in the area of intended distribution. Devices purchased in the United States or Canada must be returned to the Garmin service center in the United Kingdom, the United States, Canada, or Taiwan for service.

Marine Warranty Policy: Certain Garmin Marine products in certain areas have a longer warranty period and additional terms and conditions. Go to www.garmin.com/support/warranty_marine for more details and to see if your product is covered under the Garmin Marine Warranty Policy.

Australian Purchases: Our goods come with guarantees that cannot be excluded under the Australian Consumer Law. You are entitled to a replacement or refund for a major failure and for compensation for any other reasonably foreseeable loss or damage. You are also entitled to have the goods repaired or replaced if the goods fail to be of acceptable quality and the failure does not amount to a major failure. The benefits under our Limited Warranty are in addition to other rights and remedies under applicable law in relation to the products. Garmin Australasia, 30 Clay Place, Eastern Creek, NSW 2766, Australia. Phone: 1800 235 822.

Informations importantes sur le produit et la sécurité

⚠ AVERTISSEMENT

Si vous ne respectez pas les avertissements suivants, vous risquez un accident ou une collision pouvant entraîner des blessures graves, voire mortelles.

Avertissements relatifs à la batterie

Votre appareil contient une batterie interne non remplaçable par l'utilisateur pour diverses fonctions, telles que l'horloge en temps réel.

Le non-respect de ces consignes peut causer une diminution de la durée de vie des batteries, endommager l'appareil ou présenter un risque d'incendie, de brûlure chimique, de fuite d'électrolyte et/ou de blessure.

- N'essayez pas de retirer la batterie non remplaçable par l'utilisateur.

Avertissements d'utilisation en milieu marin

• **Vous êtes responsable de l'utilisation sûre et prudente de votre bateau.** Cet appareil est un outil qui optimisera votre capacité de pilotage. Cet appareil ne vous dégage pas de vos responsabilités en cas de non-respect de la sécurité à bord. Évitez tout danger de navigation et ne relâchez pas votre surveillance de la barre.

- L'appareil doit être utilisé uniquement comme une aide à la navigation. Ne tentez pas d'utiliser l'appareil à des fins exigeant une mesure précise de l'orientation, de la distance, de la position ou de la topographie.
- Soyez toujours prêt à reprendre les commandes du navire. Soyez vigilant à proximité des points dangereux, tels que les quais et les autres navires.
- En cours de navigation, et si l'appareil dispose de fonctions de navigation, comparez attentivement les informations affichées par l'appareil à toutes les autres sources d'information disponibles, notamment les repères visuels, les règles et restrictions locales relatives aux voies navigables, ainsi que les cartes. Pour votre sécurité, cherchez à résoudre tout dysfonctionnement ou problème avant de poursuivre la navigation.

AVIS

Si vous ignorez cette notice, vous risquez de vous blesser, d'endommager votre bien ou d'affecter négativement les fonctionnalités de l'appareil.

Avis concernant la batterie

- N'immergez pas l'appareil ni les batteries dans de l'eau ou dans d'autres liquides.
- Ne laissez pas l'appareil à proximité d'une source de chaleur ou dans un lieu où la température est très élevée, par exemple dans un véhicule sans surveillance stationné en plein soleil. Pour éviter tout dommage, sortez l'appareil de votre véhicule ou placez-le à l'abri du soleil, par exemple dans la boîte à gants.
- N'utilisez pas l'appareil si la température n'est pas comprise entre les plages de température indiquées dans le manuel imprimé fourni avec le produit.
- Si vous devez ranger l'appareil pour une période prolongée, assurez-vous que la température ambiante du lieu de stockage est toujours comprise entre les plages de température indiquées dans le manuel imprimé fourni avec le produit.

- Contactez la déchetterie locale pour plus d'informations sur la mise au rebut de l'appareil ou des batteries dans le respect des lois et réglementations locales applicables.

Programmes environnementaux

Des informations relatives au programme Garmin de recyclage des produits ainsi qu'aux directives DEEE et RoHS, à la réglementation REACH et aux autres programmes de conformité sont disponibles à l'adresse www.garmin.com/about/Garmin/environnement.

Exposition aux rayonnements à fréquence radioélectrique

Cet appareil est un transmetteur/récepteur mobile qui utilise une antenne interne pour envoyer et recevoir des champs de radiofréquences de faible puissance lors des communications de données. Les champs de radiofréquences émis par l'appareil lorsqu'il fonctionne au maximum de sa puissance et qu'il est utilisé avec des accessoires approuvés par Garmin ne dépassent pas les limites fixées par la réglementation. Pour être conforme aux exigences d'exposition aux radiofréquences, l'appareil doit être installé et utilisé en respectant la distance indiquée dans les instructions du manuel papier. L'appareil ne doit être utilisé dans aucune autre configuration. Cet appareil ne doit pas être placé ou utilisé en conjonction avec d'autres antennes ou émetteurs.

Informations concernant la radio VHF

Tous les utilisateurs sont tenus de respecter les réglementations de leur gouvernement et celles des gouvernements étrangers. Les violations de ces réglementations sont passibles de lourdes sanctions. Les fréquences de transmission de votre radio sont réservées à une utilisation marine ; toute fréquence que vous utilisez à des fins de transmission doit être spécifiquement incluse dans la licence de votre bateau. Une licence spéciale est requise pour toute utilisation terrestre, y compris lorsque votre navire se trouve sur une remorque. L'utilisation de l'ATIS est interdite en dehors des voies navigables intérieures européennes couvertes par l'Arrangement de Bâle.

Conditions de licence

De nombreux pays et administrations exigent une licence de radio marine. De plus, l'utilisateur doit être en possession d'une licence d'opérateur radio adéquate pour pouvoir utiliser du matériel de transmission marin. Contactez votre administration locale pour obtenir de plus amples informations.

Innovation, Sciences et Développement économique Canada – Conformité

Cet appareil est conforme aux normes RSS sans licence du ministère Innovation, Sciences et Développement économique Canada. Son fonctionnement est soumis aux deux conditions suivantes : (1) ce périphérique ne doit pas causer d'interférences et (2) doit accepter toute interférence, y compris les interférences pouvant entraîner un fonctionnement indésirable de l'appareil.

Déclaration de conformité

Par la présente, Garmin déclare que ce produit est conforme aux principales exigences et autres clauses pertinentes de la directive européenne 1999/5/CE. Pour prendre connaissance de l'intégralité de la déclaration de conformité, rendez-vous sur le site www.garmin.com/compliance.

Contrat de licence du logiciel

EN UTILISANT CE PRODUIT, VOUS RECONNAISSEZ ETRE LIE PAR LES TERMES DU PRESENT CONTRAT DE LICENCE DE LOGICIEL. LISEZ ATTENTIVEMENT CE CONTRAT DE LICENCE.

Garmin Ltd. et ses filiales (« Garmin ») vous concèdent une licence limitée pour l'utilisation du logiciel intégré à cet appareil (le « Logiciel ») sous la forme d'un programme binaire exécutable, dans le cadre du fonctionnement normal du produit. Tout titre, droit de propriété ou droit de propriété intellectuelle dans le Logiciel ou concernant le Logiciel est la propriété de Garmin et/ou de ses fournisseurs tiers.

Vous reconnaissez que le Logiciel est la propriété de Garmin et/ou de ses fournisseurs tiers et qu'il est protégé par les lois en vigueur aux Etats-Unis d'Amérique et par les traités internationaux relatifs aux droits d'auteur. Vous reconnaissez également que la structure, l'organisation et le code du Logiciel, dont le code source n'est pas fourni, constituent d'importants secrets de fabrication de Garmin et/ou de ses fournisseurs tiers, et que le code source du Logiciel demeure un important secret de fabrication de Garmin et/ou de ses fournisseurs tiers. Vous acceptez de ne pas décompiler, désassembler, modifier, assembler à rebours, étudier par rétro-ingénierie ou transcrire en langage humain intelligible le Logiciel ou toute partie du Logiciel, ou créer toute œuvre dérivée du Logiciel. Vous acceptez de ne pas exporter ni de réexporter le Logiciel vers un pays contrevenant aux lois de contrôle à l'exportation des Etats-Unis d'Amérique ou à celles de tout autre pays concerné.

Garantie limitée

Les produits non aéronautiques sont garantis contre tout défaut de matériel et de fabrication pendant un an à compter de leur date d'achat. Durant cette période, Garmin pourra, à son entière discrétion, réparer ou remplacer tout composant qui s'avérerait défectueux dans le cadre d'un usage normal. Ce type de réparation ou de remplacement ne sera pas facturé au client, qu'il s'agisse des composants ou de la main-d'œuvre, à condition que le client prenne en charge les frais de port. La

présente garantie limitée ne couvre pas : (i) les dommages esthétiques, tels que les éraflures, les rayures et les bosses ; (ii) les consommables, comme les piles, à moins que le dommage ne soit dû à un défaut matériel ou de fabrication ; (iii) les dommages provoqués par un accident, une utilisation abusive, une mauvaise utilisation, l'eau, une inondation, un incendie ou toute autre catastrophe naturelle ou cause extérieure ; (iv) les dommages provoqués par des fournisseurs de services non agréés par Garmin ; ou (v) les dommages sur un produit ayant été modifié sans l'autorisation écrite de Garmin ; ou (vi) les dommages sur un produit raccordé à des câbles d'alimentation et/ou des câbles de données non fournis par Garmin. En outre, Garmin se réserve le droit de refuser toute demande de service sous garantie relative à un produit ou service obtenu et/ou utilisé en violation des lois de tout pays.

Ce produit est uniquement une aide à la navigation et il ne doit pas être utilisé à d'autres fins exigeant l'évaluation précise de la direction, de la distance, de la position ou de la topographie. Garmin n'offre aucune garantie quant à l'exactitude ou à l'exhaustivité des données cartographiques.

Les réparations sont garanties pendant 90 jours. Si l'unité envoyée est toujours couverte par la garantie d'origine, cette nouvelle garantie court pendant un délai de 90 jours ou jusqu'à la fin de la période de garantie d'origine qui est d'un an, selon la plus longue des deux périodes.

La présente garantie limitée ne couvre pas, et Garmin n'est pas responsable de, toute dégradation des performances d'un produit de navigation Garmin si celui-ci a été utilisé près d'un appareil portable ou de tout autre appareil utilisant un réseau terrestre à large bande fonctionnant sur des fréquences proches de celles utilisées par tout système de positionnement par satellites (GNSS), comme le GPS. L'utilisation de tels appareils peut altérer la réception des signaux GNSS.

DANS LES LIMITES PREVUES PAR LA LOI, LES GARANTIES ET RECOURS CONTENUS DANS LA PRESENTE GARANTIE LIMITEE SONT EXCLUSIFS ET REMPLACEMENT, ET GARMIN EXCLUT EXPLICITEMENT, TOUTE AUTRE GARANTIE ET RECOURS EXPRES, IMPLICITES, LEGAUX OU AUTRES, Y COMPRIS, MAIS DE MANIERE NON LIMITATIVE, TOUTE GARANTIE IMPLICITE MARCHANDE OU D'ADEQUATION A UN USAGE PARTICULIER, TOUT RECOURS LEGAL OU AUTRES. LA PRESENTE GARANTIE VOUS OCTROIE DES DROITS PARTICULIERS ET VOUS BENEFICIEZ PEUT-ETRE D'AUTRES DROITS QUI PEUVENT VARIER D'UN ETAT A L'AUTRE. SI LES GARANTIES IMPLICITES NE PEUVENT PAS ETRE EXCLUES, ALORS LEDITES GARANTIES SONT LIMITEES A LA DUREE DE LA PRESENTE GARANTIE LIMITEE. CERTAINS ETATS INTERDISANT LA RESTRICTION DE LA DUREE D'UNE GARANTIE IMPLICITE, LES RESTRICTIONS SUSMENTIONNEES PEUVENT NE PAS VOUS CONCERNER.

EN AUCUN CAS, LA SOCIETE Garmin NE SAURAIT ETRE TENUE RESPONSABLE EN CAS DE RUPTURE DE LA GARANTIE DE TOUT DOMMAGE ACCESSOIRE, SPECIAL, INDIRECT OU CONSECUTIF RESULTANT DE L'UTILISATION, DE LA MAUVAISE UTILISATION OU DE L'IMPOSSIBILITE D'UTILISER CE PRODUIT, OU RESULTANT DE DEFAUTS DU PRODUIT. CERTAINS ETATS INTERDISANT L'EXCLUSION OU LA RESTRICTION DES DOMMAGES ACCESSOIRES OU CONSECUTIFS, LES RESTRICTIONS SUSMENTIONNEES PEUVENT NE PAS VOUS CONCERNER. Garmin se réserve le droit exclusif de réparer l'appareil ou le logiciel, de les remplacer (par un produit de remplacement neuf ou entièrement révisé) ou de proposer le remboursement intégral du prix d'achat à son entière discrétion. CE TYPE DE RECOURS SERA VOTRE RECOURS UNIQUE ET EXCLUSIF POUR TOUTE RUPTURE DE GARANTIE.

Pour bénéficier d'un service sous garantie, contactez votre revendeur agréé Garmin ou appelez le service d'assistance produit de Garmin pour obtenir les instructions relatives à l'expédition du produit, ainsi qu'un numéro de suivi RMA. Emballez avec soin l'appareil en y joignant une copie de l'original de la facture, qui fera office de preuve d'achat dans le cas de réparations sous garantie. Inscrivez lisiblement le numéro de suivi sur l'extérieur du paquet. Envoyez le périphérique, frais de port prépayés, au centre des services de garantie Garmin qui vous aura été indiqué. Rendez-vous sur www.garmin.com/support pour en savoir plus sur la manière de contacter le service d'assistance produit Garmin au sujet de la garantie. Si vous avez acheté votre appareil aux Etats-Unis, vous pouvez aussi appeler le 1-800-800-1020.

Achats dans le cadre d'enchères en ligne : les produits achetés au cours d'enchères en ligne ne peuvent faire l'objet de rabais ou d'autres offres spéciales proposés par la garantie de Garmin. Les confirmations de vente aux enchères en ligne ne sont pas acceptées dans le cadre d'une vérification sous garantie. Pour bénéficier d'un service sous garantie, l'original ou une copie de la facture dressée par le premier revendeur doit être présenté. Garmin ne procédera à aucun remplacement de composant manquant sur tout produit acheté dans le cadre d'enchères en ligne.

Achats internationaux : selon les pays, une garantie distincte peut être accordée par les distributeurs internationaux pour les appareils achetés hors des Etats-Unis. Le cas échéant, cette garantie est fournie par le distributeur du pays d'achat et ledit distributeur prend en charge les services locaux nécessaires pour votre appareil. Les garanties distributeur sont valables uniquement dans les zones de distribution visées. En cas de problème, les appareils achetés aux Etats-Unis ou au Canada doivent être renvoyés aux ateliers de réparations Garmin du Royaume-Uni, des Etats-Unis, du Canada ou de Taiwan.

Politique de garantie des produits marine : pour certains produits marine de Garmin de certaines régions du monde, la période de garantie est plus longue et des conditions supplémentaires s'appliquent. Rendez-vous sur le site www.garmin.com

[/support/warranty_marine](#) pour plus de détails et pour savoir si votre produit est couvert par la garantie des produits marine de Garmin.

GARMIN®

A01653

Quick Start Manual	2
Manuel de démarrage rapide	7
Manuale di avvio rapido	13
Schnellstartanleitung	18
Guía de inicio rápido	24



A01653 Series Quick Start Manual

Introduction

WARNING

See the *Important Safety and Product Information* guide in the product box for product warnings and other important information.

Device Overview

A01653

A01653

Item	Key	Description
①	DISTRESS	Lift the door and select to send a DSC distress call with a programmed MMSI number.
②	VOL/SQ	Press to switch between volume or squelch. Rotate to adjust the volume or squelch level.
③		Select the key that corresponds to the on-screen item to select the item.
④	SELECT	On the home screen, rotate to change the channel. On the home screen, press to toggle weather channels. Rotate to highlight an item in a list. Press to select an item.
	PWR North America: 16/9 International: 16+	Hold to turn the radio on and off. Select to toggle between preset channels.
	DSC	Select to view a menu of DSC options.
	HI/LO	Select to change the transmission mode and power settings.
	CLEAR	Select to return to the previous menu option. Select to cancel or mute an incoming DSC call.
	MENU	From the home screen, select to view configuration options. From a menu, select to return to the home screen.

Handset Overview



①	PTT	Hold to broadcast.
②	▲ or ▼	Select to change the channel on the radio.
③	North America: 16/9 International: 16+	Select to toggle between preset channels.

Home Screen

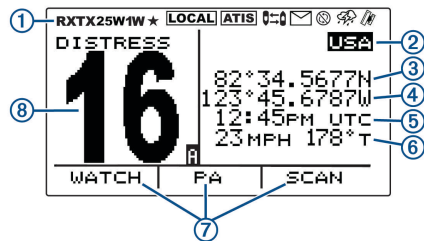



①	Current radio system status, settings, and alerts.
②	Current international, Canadian, or U.S. frequency band
③	*Current latitude
④	*Current longitude
⑤	*Current time
⑥	**Current speed over ground (SOG) or course over ground (COG)
⑦	Soft-key functions change depending on your current activity
⑧	Current working channel

*The current latitude, longitude, and time appear when the transceiver is connected to a GPS device. You can enter data manually when the transceiver is not connected to a GPS device.

** The current SOG and COG appear when the transceiver is connected to a GPS device, and the option is enabled in the menu.

System Status Icons

Icon	Status
RX	Receiving an incoming signal
TX	Transmitting
25W	Transmitting at 25 W
1W	Transmitting at 1 W
★	Saved channel
LOCAL	Local receiver mode, often used in areas with radio frequency interference (harbors)
ATIS	ATIS enabled
📶	Position tracking enabled
🚫	Auto channel changing disabled

Icon	Status
	Incoming or missed DSC call
	Weather alert
	External GPS connected

Basic Operation

Turning On and Off the Device

Hold **PWR**.

Adjusting the Radio Volume

- 1 Set the squelch level to **MIN** before you adjust the radio volume (optional).
- 2 Turn the **VOL/SQ** dial to increase or decrease the radio volume.

Adjusting the Squelch Level

You can adjust the sensitivity level of the squelch to filter out background noise. When you increase the squelch level, you hear fewer weak background signals when you are receiving.

- 1 Press the **VOL/SQ** dial.
SQUELCH appears on the screen.
- 2 Turn the **VOL/SQ** dial counter-clockwise until you hear audio.
- 3 Turn the **VOL/SQ** dial clockwise until there is no background noise.

Selecting the Frequency Band

You can switch between the USA, International, or Canadian frequency bands.



NOTE: Not all frequency bands are available on all device models.

- 1 Select **MENU > CHANNEL > Frequency band**.
- 2 Select a frequency band.

Selecting a Channel

You can select an international, Canadian, or USA channel (page 4).

Select an option:

- To select a channel on the device, turn **Channel** clockwise or counter-clockwise.
- To select a channel on the handset, select  or .

Transmitting with the Radio or Handset

- 1 Select an appropriate channel.
- 2 Ensure the channel is clear.
NOTE: You cannot obstruct the communications of other people due to Federal Communications Commission (FCC) and international guidelines.
- 3 Select **PTT** on the handset.
TX appears at the top of the screen.
- 4 Speak into the handset.
NOTE: Five minutes is the maximum time allowed for transmission. After five minutes of transmitting, PTT is disabled until you release PTT.
- 5 Release **PTT**.

Setting the Receiving Sensitivity

You can control the receiving sensitivity of the device. When you have noise in high-traffic areas or areas with electromagnetic interference, such as near cell-phone towers, you can set the receiving sensitivity to **LOC** to decrease receiver sensitivity. In remote areas and on open water, you can set the receiving sensitivity to **DIST** to ensure that you use the maximum range of the receiver.

- 1 Select **HI/LO**.
- 2 Select an option:
 - Select **LOC** to enable local sensitivity.
 - Select **DIST** to enable distant sensitivity.

Switching Between 1 W and 25 W Transmitting Modes

You can control the transmitting power of the radio. LO (1 W) is used for local transmissions, and HI (25 W) is used for distance and distress transmissions.

When two signals broadcast on the same frequency, a VHF radio receives only the stronger of the two signals. You should transmit calls other than distress calls using the lowest power setting that allows you to communicate, to reduce the possibility that your transmissions interfere with the transmissions of others.

In the USA frequency band, transmissions on channels 13 and 67 must be low (1 W) by default.

- 1 Select **HI/LO**.
- 2 Select **1W** or **25W**.

Digital Selective Calling

Digital Selective Calling

NOTE: Before you can use DSC capabilities, you must enter a Mobile Marine Safety Identity (MMSI) number. An MMSI number identifies each DSC radio, like a telephone number.

Digital Selective Calling (DSC) is a key component of the Global Maritime Distress and Safety System (GMDSS). DSC enables VHF radios to place and receive digital calls directly with other vessels and shore stations, including the USA and Canadian Coast Guards. Your radio includes full Class-D DSC capabilities.

For more information about DSC on your device, including using DSC for distress calls, see the online owner's manual (page 7).

NOTE: The device disables DSC automatically when you turn on ATIS (page 6).

Entering Your MMSI Number

NOTICE

You can enter your MMSI number only once. If you must change your MMSI number after entering it, you must take your radio to your Garmin® dealer for reprogramming.

The Mobile Marine Safety Identity (MMSI) number is a nine-digit code that acts as a DSC self-identification number, and it is required in order to use the DSC capabilities of your device. You can obtain an MMSI number from the telecommunications authority or ship registry for your country. In the USA, you can obtain an MMSI number from these sources.

- Federal Communications Commission (FCC): assignments are recognized internationally
- BoatU.S.®, Sea Tow®, or United States Power Squadrons®: assignments are for USA waters only

- 1 Select **MENU > DSC > MY MMSI**.
- 2 Turn **SELECT** clockwise or counter-clockwise to increase or decrease the number.
- 3 Press **SELECT** to accept the number.
- 4 Repeat steps 2 and 3 for each number in the sequence.
- 5 Select **ACCEPT**.
The device prompts you to confirm your identity.
- 6 Enter your MMSI number again, and select **ACCEPT**.
If the MMSI numbers you entered do not match, a message appears.
- 7 If necessary, select **RETRY** and enter the number again.

Automatic Transmitter Identification System

Automatic Transmitter Identification System (ATIS) is a vessel identification system used on certain inland waterways in some European countries. See your Garmin dealer to program your VHF radio if you plan to use your radio on waterways that are within the bounds of the Regional Arrangement Concerning the Radiotelephone Service on Inland Waterways (the Basel Agreement). ATIS is prohibited outside the European inland waterways that are covered by the Basel Agreement.

When you enable ATIS, your radio sends a data signal identifying your station at the end of every transmission. Data identifying your position is not sent, but your position is calculated through the method of triangulation by coastal stations that receive your transmissions.

To enable ATIS, you must enter your ATIS identification number (page 6), and turn on ATIS. See your Garmin dealer to determine your ATIS identification number and to learn about ATIS requirements for your region.

Your radio disables these functions when you enable ATIS.

- Digital Selective Calling (DSC)
- Dual watch and Tri watch
- Channel scanning

International channels 6, 8, 10, 11, 12, 13, 14, 71, 72, 74, and 77 restrict transmitting to low-power (1 W) when you enable ATIS.

Entering Your ATIS Identification Number

NOTICE

You can enter your ATIS identification number only once. If you must change your ATIS identification number after entering it, you must take your radio to your Garmin dealer for reprogramming.

- 1 Select **MENU > ATIS > MY ATIS ID**.
- 2 Turn **SELECT** clockwise or counter-clockwise to increase or decrease the number.
- 3 Press **SELECT** to accept the number.
- 4 Repeat steps 2 and 3 for each number in the sequence.
- 5 Select **ACCEPT**.
The device prompts you to reenter your number.
- 6 Enter your ATIS number again, and select **ACCEPT**.
If the ATIS numbers you entered do not match, a message appears.
- 7 If necessary, select **RETRY** and enter the number again.

Turning On and Off ATIS

- 1 Select **MENU > ATIS > ATIS**.
- 2 Select **ON** or **OFF**.
ATIS appears on the screen when ATIS is enabled.
- 3 Select an option:
 - To save your changes and return to the home screen, select **OK**.
 - To return to the home screen without saving your changes, select **MENU**.

Appendix

Contacting Garmin Product Support

- Go to www.garmin.com/support for in-country support information.
- In the USA, call 913-397-8200 or 1-800-800-1020.

- In the UK, call 0808 238 0000.
- In Europe, call +44 (0) 870 850 1241.

Cleaning the Outer Casing

NOTICE

Avoid chemical cleaners and solvents that can damage plastic components.

- 1 Clean the outer casing of the device (not the screen) using a cloth dampened with a mild detergent solution.
- 2 Wipe the device dry.

Cleaning the Screen

NOTICE

Cleaners containing ammonia will harm the anti-reflective coating.

The device is coated with a special anti-reflective coating which is very sensitive to waxes and abrasive cleaners.

- 1 Apply an eyeglass lens cleaner specified as safe for anti-reflective coatings to the cloth.
- 2 Gently wipe the screen with a soft, clean, lint-free cloth.

Getting the Owner's Manual

Go to www.garmin.com/manuals/A01653.

①