

# SPECIFICATION CONTROL DRAWING

## Revisions

| Rev. | Date     | Description                   | ECO No. |
|------|----------|-------------------------------|---------|
| A    | 07/12/11 | Production Release            | ----    |
| B    | 10/14/11 | Added Australian Warning text | 85765   |
|      |          |                               |         |

Dimensions and drawings for reference only. Drawings are not to scale.

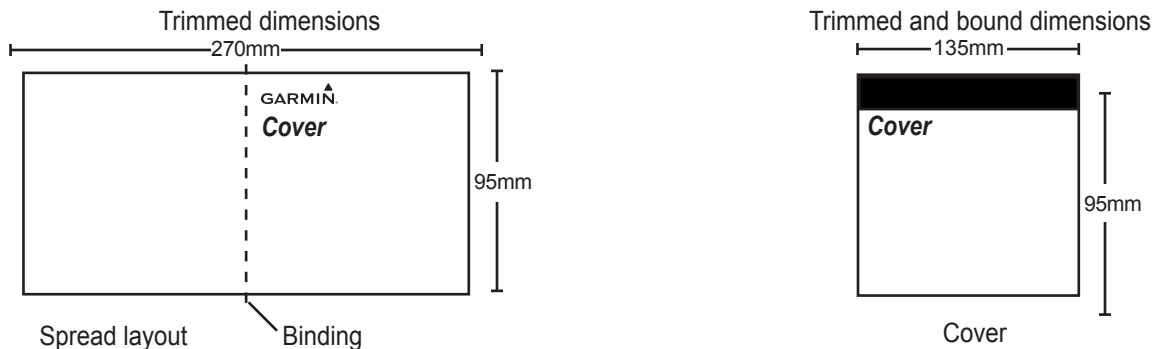

### Specifications

- Description: Production Release, ISPI, Auto (Small) (EN)
- Size: Trimmed: Width = 270mm (10.63") Height = 95mm (3.74"). Finished, Folded: Width = 135mm (5.315"), Height = 95mm (3.74").
- Tolerance:  $\pm 0.0787"$  ( $\pm 2$  mm)
- Pagination: 4 pages
- Material: 80-lb Woodfree. Approved Equivalents Allowed
- Finish: N/A
- Color: Black and white
- Bindery: Saddle-stitched (72 pages maximum). Approved Equivalents Allowed.
- Folds: One vertical fold down the center
- Electronic Artwork: Shall conform to Garmin Archive 190-00720-70\_0B.zip
- Languages: English
- Notes: This part shall comply with Garmin Banned & Restricted Substances (GPN 001-00211-00).

### Files

The following files have been archived under the above ARCHIVE FILENAME.

| File Name                 | File Contents   |
|---------------------------|---|
| 190-00720-70_0B.indd      | InDesign CS4 for PC, Formatted manual                                 |
| 190-00720-70_0B_Spec.indd | InDesign CS4 for PC, Document specification sheet                     |
| 190-00720-70_0B_Spec.pdf  | Portable Document format, Specification sheet                         |
| 190-00720-70_0B.pdf       | Portable Document Format, Manual and specification sheet for printing |
| Links                     | Graphic files (eps, bmp, etc.)  |
| Fonts                     | Font files  |
| ISPI_Auto_Small_EN.pdf    | Portable Document Format, for online                                  |

**CONFIDENTIAL**  
This drawing and the specifications contained herein are the property of Garmin Ltd. or its subsidiaries and may not be reproduced or used in whole or in part as the basis for manufacture or sale of products without written permission.



Garmin Ltd. or its subsidiaries  
C/O Garmin International, Inc.  
1200 E. 151st Street  
Olathe, Kansas 66062 U.S.A.

| Initials         |  |  | Date |          |  | TITLE |                         |                     |          |
|------------------|--|--|------|----------|--|-------|-------------------------|---------------------|----------|
| Drawn By:        |  |  | KAR  | 07/12/11 |  |       | ISPI, Auto (Small) (EN) |                     |          |
| Checked By:      |  |  | JHH  | 7/12/11  |  |       | SIZE                    | PART NO:            | REV:     |
| Project Manager: |  |  | RRJ  | 7/12/11  |  |       | <b>A</b>                | <b>190-00720-70</b> | <b>B</b> |
| Approved By:     |  |  | MKW  | 7/12/11  |  |       | SCALE                   |                     | Sheet    |
|                  |  |  |      |          |  |       | <b>N/A</b>              |                     | Of       |
|                  |  |  |      |          |  |       |                         | 1                   | 5        |



## Important Safety and Product Information

### WARNING

Failure to avoid the following potentially hazardous situations could result in an accident or collision resulting in death or serious injury.

#### Installation and Operation Warnings

- When installing the device in a vehicle, place the device securely so it does not obstruct the driver's view of the road ① or interfere with vehicle operating controls, such as the steering wheel, foot pedals, or transmission levers. Do not place unsecured on the vehicle dashboard ②. Do not place the device in front of or above any airbag ③.

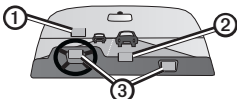

- The windshield mount may not stay attached to the windshield in all circumstances. Do not place the mount where it will become a distraction if the mount should become detached. Keep your windshield clean to help ensure that the mount stays on the windshield.
- Always use your best judgement, and operate the vehicle in a safe manner. **Do not become distracted by the device while driving, and always be fully aware of all driving conditions.** Minimize the amount of time spent viewing the device screen while driving and use voice prompts when possible.
- Do not input destinations, change settings, or access any functions requiring prolonged use of the device controls while driving. Pull over in a safe and legal manner before attempting such operations.

- When navigating, carefully compare information displayed on the device to all available navigation sources, including road signs, road closures, road conditions, traffic congestion, weather conditions, and other factors that may affect safety while driving. For safety, always resolve any discrepancies before continuing navigation, and defer to posted road signs and road conditions.
- The device is designed to provide route suggestions. It is not a replacement for driver attentiveness and good judgement. **Do not follow route suggestions if they suggest an unsafe or illegal maneuver or would place the vehicle in an unsafe situation.**

#### Battery Warnings

If these guidelines are not followed, the internal lithium-ion battery may experience a shortened life span or may present a risk of damage to the GPS device, fire, chemical burn, electrolyte leak, and/or injury.

- Do not leave the device exposed to a heat source or in a high-temperature location, such as in the sun in an unattended vehicle. To prevent damage, remove the device from the vehicle or store it out of direct sunlight, such as in the glove box.
- Do not puncture or incinerate the device or battery.
- When storing the device for an extended time, store within the following temperature range: from 32°F to 77°F (from 0°C to 25°C).
- Do not operate the device outside of the following temperature range: from -4°F to 131°F (from -20°C to 55°C).
- Contact your local waste disposal department to dispose of the device/battery in accordance with applicable local laws and regulations.

#### Additional User-Replaceable Battery Warnings:

- Do not use a sharp object to remove the battery.
- Keep the battery away from children.





- Do not disassemble, puncture, or damage the battery.
- If using an external battery charger, only use the Garmin accessory approved for your product.
- Never replace the battery with the correct replacement battery. Using another battery presents a risk of fire or explosion. To purchase a replacement battery, see your Garmin dealer or the Garmin Web site.

#### **Additional Non-User-Replaceable Battery Warning:**

- Do not remove or attempt to remove the non-user-replaceable battery.

### **NOTICE**

#### **Windshield Mounting Legal Restrictions**

Before using the suction cup mount on your windshield, check the state and local laws and ordinances where you drive. Some state laws prohibit drivers from using suction mounts on their windshields while operating motor vehicles. Other state laws allow the suction mount to be located only in specific locations on the windshield. Many other states have enacted restrictions against placing objects on the windshield in locations that obstruct the driver's vision. **IT IS THE USER'S RESPONSIBILITY TO MOUNT THE GARMIN DEVICE IN COMPLIANCE WITH ALL APPLICABLE LAWS AND ORDINANCES.** Where required, other Garmin dashboard or friction mount options should be used. Always mount your Garmin device in a location that does not obstruct the driver's view of the road. Garmin does not assume any responsibility for any fines, penalties, or damages that may be incurred as a result of any state or local law or ordinance relating to the use of your Garmin device.

#### **Map Data Information**

Garmin uses a combination of governmental and private data sources. Virtually all data sources contain some inaccurate or incomplete data. In some countries, complete and accurate map information is either not available or is prohibitively expensive.

#### **Declaration of Conformity**

Hereby, Garmin, declares that this product is in compliance with the essential requirements and other relevant provisions of Directive 1999/5/EC. To view the full Declaration of Conformity, go to [www.garmin.com/compliance](http://www.garmin.com/compliance).

#### **CE Mark**

If the CE Alert mark is present on your device, this device uses frequency bands that are not harmonised throughout the EU, and/or the intended use of the device is subject to restrictions made by one or more Member States.

#### **FCC Compliance**

This device complies with part 15 of the FCC Rules. Operation is subject to the following two conditions: (1) this device may not cause harmful interference, and (2) this device must accept any interference received, including interference that may cause undesired operation. This equipment has been tested and found to comply with the limits for a Class B digital device, pursuant to part 15 of the FCC rules. These limits are designed to provide reasonable protection against harmful interference in a residential installation. This equipment generates, uses, and can radiate radio frequency energy and may cause harmful interference to radio communications if not installed and used in accordance with the instructions. However, there is no guarantee that interference will not occur in a particular installation. If this equipment does cause harmful interference to radio or television reception, which can be determined by turning the equipment off and on, the user is



encouraged to try to correct the interference by one of the following measures:

- Reorient or relocate the receiving antenna.
- Increase the separation between the equipment and the receiver.
- Connect the equipment into an outlet that is on a different circuit from the GPS unit.
- Consult the dealer or an experienced radio/TV technician for help.

This product does not contain any user-serviceable parts. Repairs should only be made by an authorized Garmin service center. Unauthorized repairs or modifications could result in permanent damage to the equipment, and void your warranty and your authority to operate this device under Part 15 regulations.

### Industry Canada Compliance

Category I radiocommunication devices comply with Industry Canada Standard RSS-210. Category II radiocommunication devices comply with Industry Canada Standard RSS-310. This device complies with Industry Canada license-exempt RSS standard(s). Operation is subject to the following two conditions: (1) this device may not cause interference, and (2) this device must accept any interference, including interference that may cause undesired operation of the device.

### Limited Warranty

This Garmin product is warranted to be free from defects in materials or workmanship for one year from the date of purchase. Within this period, Garmin will, at its sole option, repair or replace any components that fail in normal use. Such repairs or replacement will be made at no charge to the customer for parts or labor, provided that the customer shall be responsible for any transportation cost. This warranty does not apply to: (i) cosmetic damage, such as scratches, nicks and dents; (ii) consumable parts, such as batteries,

unless product damage has occurred due to a defect in materials or workmanship; (iii) damage caused by accident, abuse, misuse, water, flood, fire, or other acts of nature or external causes; (iv) damage caused by service performed by anyone who is not an authorized service provider of Garmin; or (v) damage to a product that has been modified or altered without the written permission of Garmin. In addition, Garmin reserves the right to refuse warranty claims against products or services that are obtained and/or used in contravention of the laws of any country.

This product is intended to be used only as a travel aid and must not be used for any purpose requiring precise measurement of direction, distance, location or topography. Garmin makes no warranty as to the accuracy or completeness of map data in this product.

THE WARRANTIES AND REMEDIES CONTAINED HEREIN ARE EXCLUSIVE AND IN LIEU OF ALL OTHER WARRANTIES EXPRESS, IMPLIED, OR STATUTORY, INCLUDING ANY LIABILITY ARISING UNDER ANY WARRANTY OF MERCHANTABILITY OR FITNESS FOR A PARTICULAR PURPOSE, STATUTORY OR OTHERWISE. THIS WARRANTY GIVES YOU SPECIFIC LEGAL RIGHTS, WHICH MAY VARY FROM STATE TO STATE.

IN NO EVENT SHALL GARMIN BE LIABLE FOR ANY INCIDENTAL, SPECIAL, INDIRECT OR CONSEQUENTIAL DAMAGES, INCLUDING, WITHOUT LIMITATION, DAMAGES FOR ANY TRAFFIC FINES OR CITATIONS, WHETHER RESULTING FROM THE USE, MISUSE OR INABILITY TO USE THE PRODUCT OR FROM DEFECTS IN THE PRODUCT. SOME STATES DO NOT ALLOW THE EXCLUSION OF INCIDENTAL OR CONSEQUENTIAL DAMAGES, SO THE ABOVE LIMITATIONS MAY NOT APPLY TO YOU.

Garmin retains the exclusive right to repair or replace (with a new or newly-overhauled replacement product) the device or software or offer a full refund of the purchase price at its sole discretion. SUCH





**REMEDY SHALL BE YOUR SOLE AND EXCLUSIVE REMEDY FOR ANY BREACH OF WARRANTY.**

To obtain warranty service, contact your local Garmin authorized dealer or call Garmin Product Support for shipping instructions and an RMA tracking number. Securely pack the device and a copy of the original sales receipt, which is required as the proof of purchase for warranty repairs. Write the tracking number clearly on the outside of the package. Send the device, freight charges prepaid, to any Garmin warranty service station.

**Online Auction Purchases:** Products purchased through online auctions are not eligible for warranty coverage. Online auction confirmations are not accepted for warranty verification. To obtain warranty service, an original or copy of the sales receipt from the original retailer is required. Garmin will not replace missing components from any package purchased through an online auction.

**International Purchases:** A separate warranty may be provided by international distributors for devices purchased outside the United States depending on the country. If applicable, this warranty is

provided by the local in-country distributor and this distributor provides local service for your device. Distributor warranties are only valid in the area of intended distribution. Devices purchased in the United States or Canada must be returned to the Garmin service center in the United Kingdom, the United States, Canada, or Taiwan for service.

**Australian Purchases:** Our goods come with guarantees that cannot be excluded under the Australian Consumer Law. You are entitled to a replacement or refund for a major failure and for compensation for any other reasonably foreseeable loss or damage. You are also entitled to have the goods repaired or replaced if the goods fail to be of acceptable quality and the failure does not amount to a major failure. The benefits under our Limited Warranty are in addition to other rights and remedies under applicable law in relation to the products.

Garmin Australasia  
Unit 19, 167 Prospect Highway  
Seven Hills, NSW, Australia, 2147  
Phone: 1800 822 235



© 2011 Garmin Ltd. or its subsidiaries

[www.garmin.com](http://www.garmin.com)



Garmin International, Inc.  
1200 East 151<sup>st</sup> Street,  
Olathe, Kansas 66062, USA

Garmin (Europe) Ltd.  
Liberty House,  
Hounslow Business Park,  
Southampton, Hampshire, SO40 9LR UK

Garmin Corporation  
No. 68, Zhangshu 2<sup>nd</sup> Road,  
Xizhi Dist. New Taipei City, 221,  
Taiwan (R.O.C.)

October 2011

190-00720-70 Rev. B

Printed in Taiwan

