



## GNT™ 10 Installation Instructions

The GNT 10 extends the range of Garmin® wireless marine devices, such as a remote control or wireless mouse, and adds additional capabilities to more feature-rich wireless devices, such as the quatix™ watch. The GNT 10 connects to an existing NMEA 2000® network on your boat. Additional GNT 10 devices can be installed on your NMEA 2000 network to provide a larger coverage area on your boat.

### Important Safety Information

#### CAUTION

Always wear safety goggles, ear protection, and a dust mask when drilling, cutting, or sanding.

#### NOTICE

When drilling or cutting, always check what is on the opposite side of the surface.

### Contacting Garmin Product Support

- Go to [www.garmin.com/support](http://www.garmin.com/support) and click **Contact Support** for in-country support information.
- In the USA, call (913) 397.8200 or (800) 800.1020.
- In the UK, call 0808 2380000.
- In Europe, call +44 (0) 870.8501241.

### Mounting Considerations

#### NOTICE

This device should be mounted in a location that is not exposed to extreme temperatures or conditions. The temperature range for this device is listed in the product specifications. Extended exposure to temperatures exceeding the specified temperature range, in storage or operating conditions, may cause device failure. Extreme-temperature-induced damage and related consequences are not covered by the warranty.

When selecting a mounting location, observe these considerations.

- Metal and other dense materials may inhibit communication between this device and Garmin wireless marine devices. The intended mounting location must be tested to make sure this device reliably communicates with your wireless devices everywhere you plan to use them on the boat.
- You can use the included screws to mount the device on your boat. If the included screws are not appropriate for the mounting surface, suitable hardware must be purchased separately.

### Mounting the Device

- 1 Determine the mounting location.
- 2 Using the device as a template, mark the two pilot hole locations on the mounting surface.
- 3 Using a 1/8 in. (3 mm) bit, drill the pilot holes.
- 4 Use the included screws to attach the device to the mounting surface.

### NMEA 2000 Connection Considerations

- This device connects to an existing NMEA 2000 network on your boat.

- If you are unfamiliar with NMEA 2000, you should read the “NMEA 2000 Network Fundamentals” chapter of the *Technical Reference for NMEA 2000 Products*, available on the Garmin web site. Click the “Manuals” link on the product page for your device at [www.garmin.com](http://www.garmin.com).
- If the cable connected to the device is not long enough to reach your NMEA 2000 network, an extension of up to 16.5 ft. (5 m) can be used, according to the NMEA 2000 guidelines.

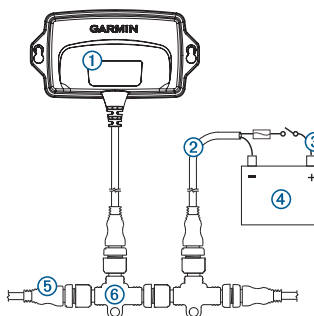

Item	Description
①	GNT 10 device
②	NMEA 2000 power cable (existing; not included)
③	Ignition or in-line switch (existing; not included)
④	12 Vdc power source
⑤	NMEA 2000 terminator or backbone cable (existing; not included)
⑥	NMEA 2000 T-connector (included)

### About the Status LED

The device has a two-color LED that you can use to troubleshoot problems, if necessary. The LED is labeled STATUS on the device.

Color	State	Status
Green	Flashing	The device is working correctly.
	Solid	The device software is being updated
Red	Flashing slowly	The device is starting up. If the LED does not change to flashing green after a short time, the device may not be working correctly. A software update using a Garmin chartplotter connected to the same NMEA 2000 network may correct the problem.
	Flashing quickly	The device is not receiving NMEA 2000 data. The NMEA 2000 network should be checked for proper installation and operation.

### Auto MOB

When paired with a Garmin quatix watch, this device is capable of triggering an automatic man overboard (MOB) event.

A Garmin quatix watch must be paired with this device for the auto MOB feature to work properly. The owner's manual provided with your watch contains detailed instructions on pairing and auto MOB setup.

After auto MOB is enabled on a paired watch, this device monitors the connection with the watch. When the connection to the watch is lost for ten seconds, this device triggers a system-wide MOB event. During an MOB event, an MOB waypoint and alert appear on all connected Garmin chartplotters.

The owner's manual provided with your Garmin chartplotter contains additional information on MOB features and actions.

## Specifications

Specification	Measurement
Dimensions (W×H×D)	5 <sup>5</sup> / <sub>16</sub> × 2 <sup>51</sup> / <sub>64</sub> × 1 <sup>11</sup> / <sub>16</sub> in. (135 × 71 × 26 mm)
Weight	6.63 oz. (188 g)
Temperature range	From 5° to 158°F (from -15° to 70°C)
Material	Fully gasketed, high-impact plastic, waterproof to IEC 60529 IPX7 standards
Compass-safe distance	1 <sup>31</sup> / <sub>32</sub> in. (50 mm)
NMEA 2000 LEN	1

### NMEA 2000 PGN Information

Type	PGN	Description
Transmit and receive	059392	ISO acknowledgment
	060928	ISO address claim
	126208	NMEA®: Command, request, and acknowledge group function
Transmit	126464	Transmit PGN list group function
	126996	Product information

Type	PGN	Description
Receive	059904	ISO request
	127250	Vessel heading
	127258	Magnetic variance
	127488	Engine parameters: Rapid update
	127489	Engine parameters: Dynamic
	127505	Fluid level
	127508	Battery status
	128259	Speed: Water referenced
	128267	Water depth
	129025	Position: Rapid update
	129026	COG and SOG : Rapid update
	129029	GNSS position data
	129283	Cross track error
	129284	Navigation data
	129285	Navigation route and waypoint info
	130306	Wind data
	130312	Temperature
	130314	Actual pressure

**Garmin International, Inc.**  
1200 East 151st Street  
Olathe, Kansas 66062, USA

**Garmin (Europe) Ltd.**  
Liberty House, Hounslow Business Park  
Southampton, Hampshire, SO40 9LR UK

**Garmin Corporation**  
No. 68, Zhangshu 2nd Road, Xizhi Dist.  
New Taipei City, 221, Taiwan (R.O.C.)

Garmin® and the Garmin logo are trademarks of Garmin Ltd. or its subsidiaries, registered in the USA and other countries. GNT™ and quatix™ are trademarks of Garmin Ltd. or its subsidiaries. These trademarks may not be used without the express permission of Garmin.

NMEA 2000® and the NMEA 2000 logo are registered trademarks of the National Marine Electronics Association.

