

GARMIN[®]

GMR™ 18 XHD/24 XHD/18 HD+

INSTALLATION INSTRUCTIONS

Important Safety Information

⚠ WARNING

Failure to follow these warnings, cautions, and notices could result in personal injury, damage to the vessel or device, or poor product performance.

See the *Important Safety and Product Information* guide in the product box for product warnings and other important information.

The radar transmits electromagnetic energy. To avoid possible personal injury, damage to the vessel or device, or poor product performance, ensure that the radar is installed according to the recommendations in these instructions and that all personnel are clear of the path of the radar beam before transmitting. When properly installed and operated, the use of this radar conforms to the requirements of ANSI/IEEE C95.1-1992 Standard for Safety Levels with Respect to Human Exposure to Radio Frequency Electromagnetic Fields.

To avoid possible personal injury, do not look directly at the antenna at close range when the radar is transmitting. Eyes are the most sensitive part of the body to electromagnetic energy.

When connecting the power cable, do not remove the in-line fuse holder. To prevent the possibility of injury or product damage caused by fire or overheating, the appropriate fuse must be in place as indicated in the product specifications. In addition, connecting the power cable without the appropriate fuse in place voids the product warranty.

⚠ CAUTION

This device should be used only as a navigational aid. Using the device for any purpose requiring precise measurement or direction, distance, location, or topography may result in personal injury or damage to the vessel.

To avoid possible personal injury, always wear safety goggles, ear protection, and a dust mask when drilling, cutting, or sanding.

Opening the device may result in personal injury and/or damage to the device. This device contains no user-serviceable parts, and should be opened only by a Garmin[®] authorized service technician. Any damage resulting from opening the unit by anyone other than a Garmin authorized service technician will not be covered by the Garmin warranty.

NOTICE

When drilling or cutting, always check what is on the opposite side of the surface to avoid damaging the vessel.

Software Update

You may need to update the device and chartplotter software when you install this device. See your Garmin chartplotter owner's manual for the full software-update instructions.

Tools Needed

- Drill
- 9.5 mm (³/₈ in.) drill bit
- 32 mm (1 ¹/₄ in.) drill bit (optional)
- 4 mm (¹³/₃₂ in.) hex wrench
- 13 mm (¹/₂ in.) wrench and torque wrench
- Marine sealant

Mounting Considerations

To complete the installation, you need the appropriate fasteners, tools, and mounts. These items are available at most marine dealers.

- It is highly recommended that the device is mounted out of range of personnel, with the horizontal beam width above head height. To avoid exposure to harmful radio frequency (RF) levels, the device should not be mounted closer to people than the maximum safe distance value listed in the product specifications.
- The device should be mounted high above the ship's keel line with minimal blockage between the vessel and the radar beam. Obstructions may cause blind and shadow sectors, or generate false echoes. The higher the installation position, the farther the radome can detect targets.
- The device should be mounted on a flat surface or a platform that is parallel to the vessel's water line and is sturdy enough to support the device's weight. The weight for each model is listed in the product specifications.
- Most radar beams spread vertically 12.5° above ① and 12.5° below ② the radome's radiating element. On vessels with higher bow angles at cruise speed, the installation angle can be lowered to point the beam slightly downward to the waterline while at rest. Use shims if necessary.

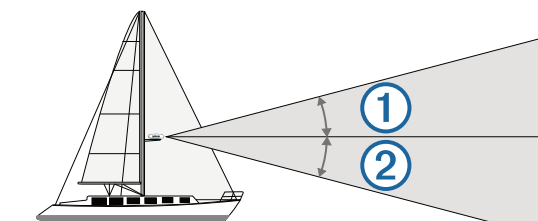

- The radome has two mounting options when installed on a standard marine mount. One mounting option is closer to the center of the radome ③, and the second option is offset towards the back ④ to move the radar further away from the mast.

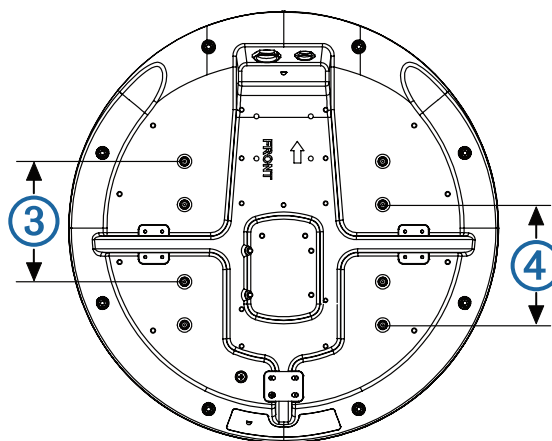

- The device should be mounted away from heat sources such as smoke stacks and lights.
- The device should be mounted at a different level than horizontal spreaders and mast crosstrees.
- To avoid interference with a magnetic compass, the device should not be mounted closer to a compass than the compass-safe distance value listed in the product specifications.
- Other electronics and cables should be mounted more than 2 m (6 ¹/₂ ft.) from the radar beam path.
- GPS antennas should be either above or below the radar beam path.
- The device should be mounted at least 1 m (40 in.) from any transmitting equipment.



- The device should be mounted at least 1 m (40 in.) away from cables carrying radio signals such as VHF radios, cables, and antennas.
For Single Side Band (SSB) radios, increase the distance to 2 m (6 ½ ft.).

Mounting the Radar

Before you mount the radar, you must review the mounting location considerations and select a mounting location.

NOTE: The supplied M8 x 1.25 x 60 threaded rods can be used on mounting thicknesses of 5 to 30 mm ($\frac{3}{16}$ to $1\frac{3}{16}$ in.) (recommended). For surfaces over 30 mm ($1\frac{3}{16}$ in.), use longer threaded rods.

- If you are not installing the device on a pre-drilled Garmin-compatible radar mount, use the included mounting template to drill four 9.5 mm ($\frac{3}{8}$ in.) mounting holes.
- Install the locking ring and o-ring on the end of the Garmin Marine Network cable.
- Connect the power cable to the power port ① and the network cable to the network port ②.

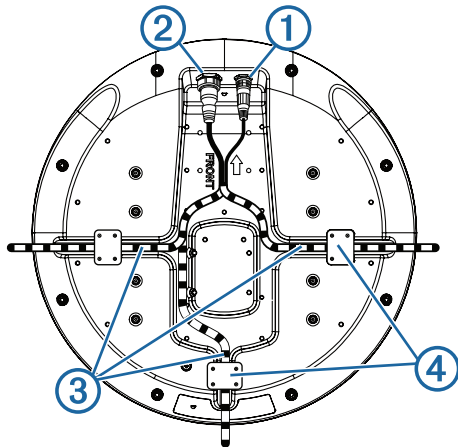

- Press the cables into any of the guide grooves ③ on the bottom of the case, and secure them using a cable hold-down plate ④.
The cables should be bent or twisted as little as possible.
- Position the radome on the mounting surface with the triangular mark on the case aligned to the front of the vessel.
- Apply the included anti-seize compound to the threads of the four M8 x 1.25 x 60 threaded rods.
- Insert the four threaded rods into the mounting holes on the bottom of the radome.
Up to 50 mm (2 in.) of the threaded rods may extend below the radome.
- Apply a bead of marine sealant on the mounting surface around each mounting hole.
- Fasten the radome ⑤ to the mounting surface ⑥ using the threaded rods ⑦, flat washers ⑧, spring washers ⑨, and hex nuts ⑩.

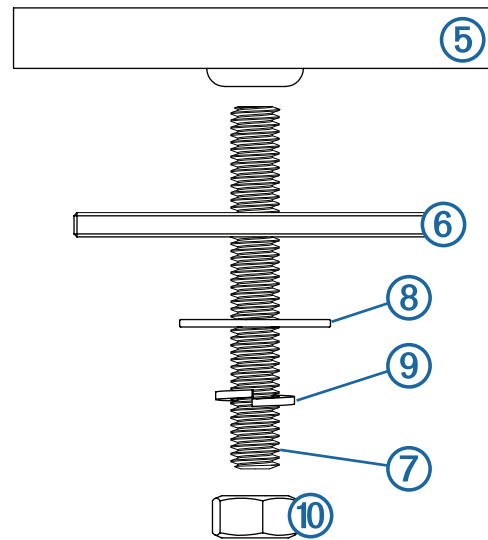

- Using a torque wrench, tighten the nuts from 13.7 to 18.6 N-m (10 to 14 lbf-in.) of force.

Cable Considerations

It may be necessary to drill 32 mm ($1\frac{1}{4}$ in.) holes for routing the power or network cables.

- When routing both the power and network cables through the same hole, you must route the network cable before the power cable.
- You must apply marine sealant to the hole after the cables are in place to ensure a waterproof seal.

If the routing hole must be made in a visible location, decorative cable grommets can be purchased from Garmin or a Garmin dealer (optional).

- If needed, the grommet can be trimmed to enable you to route both the network and the power cable through the same hole.
- The optional grommet does NOT provide a waterproof seal. You must apply marine sealant to the grommet after the cables are in place to ensure a waterproof seal.

When installing the network and power cables, you should observe these considerations.

- Cutting the Garmin Marine Network cable is not recommended, but a field install kit can be purchased from Garmin or a Garmin dealer if cutting the network cable is necessary.
- To ensure safety, appropriate tie-wraps, fasteners, and sealant should be used to secure the cable along the route and through any bulkheads or the deck.
- Cables should not be run near moving objects and high-heat sources or through doorways and bilges.
- To avoid interference with other equipment, network and power cables should not be run next to or parallel to other cables, such as radio antenna lines or power cables. If this is not possible, the cables should be shielded with metal conduit or a form of EMI shielding.
- The power cable should be installed as close to the battery source as possible.
 - If it is necessary to extend the power cable, the appropriate gauge of wire must be used (*Power Cable Extensions*, page 3).
 - Incorrectly extended runs of cable may cause the radar to malfunction due to insufficient power transmission.

Connecting the Power Cable

⚠ WARNING

When connecting the power cable, do not remove the in-line fuse holder. To prevent the possibility of injury or product damage caused by fire or overheating, the appropriate fuse must be in place as indicated in the product specifications. In addition, connecting the power cable without the appropriate fuse in place voids the product warranty.

- 1 Route the power cable from the device to the power source.
- 2 Connect the red wire to the positive (+) battery terminal, and connect the black wire to the negative (-) battery terminal.
- 3 If you have not already done so, connect the power cable to the device by turning the locking ring clockwise.

Power Cable Extensions

Connecting the power cable directly to the battery is recommended. If it is necessary to extend the cable, the appropriate gauge of wire must be used for the length of the extension.

Distance	Wire Gauge
2 m (6.5 ft.)	16 AWG (1.31 mm ²)
4 m (13 ft.)	14 AWG (2.08 mm ²)
6 m (19 ft.)	12 AWG (3.31 mm ²)

Connecting to a Device or to the Marine Network

You can connect the radar either directly to a radar-compatible Garmin device or to a Garmin Marine Network to share radar information with all connected devices.

NOTE: Not all Garmin devices are compatible with the Garmin Marine Network. See the installation instructions or owner's manual provided with your device for more information.

- 1 Route the network cable to your compatible Garmin device.
- 2 If you have not already done so, install the locking rings and o-rings on the end of the network cable.
- 3 Select an option:
 - If the Garmin device is not compatible with the Garmin Marine Network, connect the network cable to the port labeled RADAR.
 - If the device is compatible with the Garmin Marine Network, connect the network cable to the port labeled NETWORK.

Radar Operation

All functions of this radar are controlled with your Garmin chartplotter. See the Radar section of your chartplotter's owner's manual for operating instructions. To download the latest manual, go to support.garmin.com.

If you have more than one radar on your boat, you must be viewing the radar screen for the radar you want to configure.

Measuring the Potential Front-of-Boat Offset

The front-of-boat offset compensates for the physical location of the radar scanner on a boat, if the radar scanner does not align with the bow-stern axis.

- 1 Using a magnetic compass, take an optical bearing of a stationary target located within viewable range.
- 2 Measure the target bearing on the radar.
- 3 If the bearing deviation is more than +/- 1°, set the front-of-boat offset.

Setting the Front-of-Boat Offset

Before you can set the front-of-boat offset, you must measure the potential front-of-boat offset.

The front-of-boat offset setting configured for use in one radar mode is applied to every other radar mode and to the Radar overlay.

- 1 From a Radar screen or the Radar overlay, select **Menu > Radar Setup > Installation > Front of Boat**.
- 2 Select **Up** or **Down** to adjust the offset.

Specifications

GMR 18 xHD/18 HD+ weight	7.7 kg (16.95 lb.)
GMR 24 xHD weight	9.5 kg (20.9 lb.)
Temperature range	From -15 to 70°C (from 5 to 158°F)
Case material	Thermoplastic resin
Maximum antenna rotation speed GMR 18/24 xHD	48 RPM
Maximum antenna rotation speed GMR 18 HD+	24 RPM
Power input source	From 11 to 35 Vdc, 3.5 A

Fuse	7.5 A
Power output	4 kW peak
RF transmit frequency	9410 MHz nominal
GMR 18 HD+ and 18 xHD beam width	5.2 degrees
GMR 24 xHD beam width	3.7 degrees
Maximum range GMR 18/24 xHD	48 nm
Maximum range GMR 18 HD+	36 nm
Minimum range	20 m (66 ft.)
Range discrimination	16 m (52.5 ft.)
Compass-safe distance	1 m (3.28 ft.)

Minimum Safe Operating Distance

When it is transmitting, the radar should be located in a position on the vessel that is at least this far from people. IEC 60936-1, clause 3-27.1, specifies the maximum distances from the antenna at which radio frequency (RF) levels can be expected.

These minimum safe distances apply for a transmitting radar with a rotating antenna, and are much larger when the antenna is not rotating. If rotation of the antenna is obstructed for any reason, the transmitter will automatically turn off.

Model	100 W/m ²	50 W/m ²	10 W/m ²
GMR 18 xHD/18 HD+	0.08 m (3.15 in.)	0.11 m (4.33 in.)	0.25 m (9.84 in.)
GMR 24 xHD	0.08 m (3.15 in.)	0.11 m (4.33 in.)	0.24 m (9.45 in.)

Detailed Dimensions

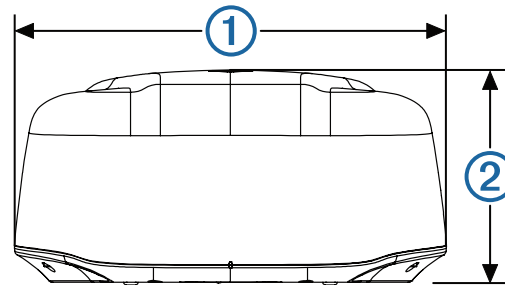

Item	GMR 18 xHD/18 HD+	GMR 24 xHD
Length	508.2 mm (20 in.)	645.4 mm (25 7/16 in.)
① (width)	504.7 mm (19 7/8 in.)	642.5 mm (25 5/16 in.)
② (height)	248.3 mm (9 3/4 in.)	250.3 mm (9 7/8 in.)

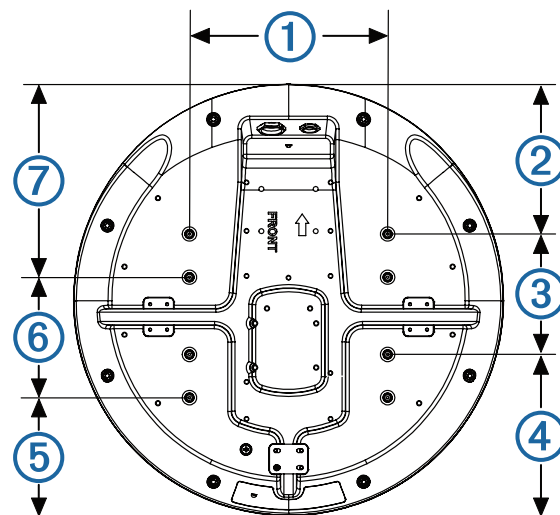

Item	GMR 18 xHD/18 HD+	GMR 24 xHD
①	233 mm (9 ³ / ₁₆ in.)	233 mm (9 ³ / ₁₆ in.)
②	176.7 mm (6 ¹⁵ / ₁₆ in.)	245.4 mm (9 ¹¹ / ₁₆ in.)
③	141.5 mm (5 ⁹ / ₁₆ in.)	141.5 mm (5 ⁹ / ₁₆ in.)
④	190 mm (7 ¹ / ₂ in.)	258.5 mm (10 ³ / ₁₆ in.)
⑤	139.2 mm (5 ¹ / ₂ in.)	207.7 mm (8 ³ / ₁₆ in.)
⑥	141.5 mm (5 ⁹ / ₁₆ in.)	141.5 mm (5 ⁹ / ₁₆ in.)
⑦	227.5 mm (8 ¹⁵ / ₁₆ in.)	296.2 mm (9 ¹¹ / ₁₆ in.)

Open-Source Software License

To view the open-source software license(s) used in this product, go to developer.garmin.com/open-source/linux/.

Installation Troubleshooting

Symptom	Possible Causes
The radar does not turn on. The status LED is not on.	<ul style="list-style-type: none"> The power cable may not be connected correctly to the device or to the battery. Check all connections. The inline fuse may have blown. Check the fuse and replace it if necessary. The wire gauge used to extend the power cable may be too small for the length of the extension. Check the table provided in the Power Cable Extensions section of these instructions to make sure the correct wire gauge is used (<i>Power Cable Extensions</i>, page 3).
The radar is not available on the Garmin device or on devices connected to the Garmin Marine Network.	<ul style="list-style-type: none"> The radar may not be powering on. Check the status LED. The device software may not be up-to-date. Update the software on the device or on the Garmin Marine Network. The network cable may not be connected correctly to the device or to the Garmin Marine Network. Check all connections. If a field-installable network connector was used, it may have been installed improperly. Check the connector.

The status LED is located on the product label, and can help troubleshoot installation problems.

Status LED Color and Activity	Radar Status
Solid red	The radar is getting ready for use. The LED should be solid red briefly and change to flashing green.
Flashing green	The radar is operating properly.
Flashing orange	The radar software is being updated.
Flashing red	The radar has encountered an error. Contact Garmin product support for assistance.

Contacting Garmin Support

- Go to support.garmin.com for help and information, such as product manuals, frequently asked questions, videos, and customer support.
- In the USA, call 913-397-8200 or 1-800-800-1020.
- In the UK, call 0808 238 0000.
- In Europe, call +44 (0) 870 850 1241.

© 2016–2020 Garmin Ltd. or its subsidiaries

Garmin® and the Garmin logo are trademarks of Garmin Ltd. or its subsidiaries, registered in the USA and other countries. GMR™ is a trademarks of Garmin Ltd. or its subsidiaries. These trademarks may not be used without the express permission of Garmin.