

Garmin A03302 SBD Transceiver Module

Specification Document

Garmin Ltd. or its subsidiaries
c/o Garmin International, Inc.
1200 E. 151st Street
Olathe, Kansas 66062 U.S.A.

Revision History

Revision	Date	Description of Change	ECO #
1	02/26/2018	Initial Release	

1. Overview

1.1 Purpose

This document defines requirements for integrating the surface mount Garmin A03302 2-way satellite transceiver module with a host design.

1.2 Introduction

The A03302 module is a standalone 2-way satellite communication short burst data transceiver solution.

The module is designed as a surface mount, package-on-package (POP) PCB; requiring a mating area on the host PCB of approximately 31mm X 38mm.

A host processor is required to interface to the module via UART. The module includes a GPS pass-through option, allowing for a single antenna solution for both GNSS and satellite communication. If this option is not used, the GPS_LNA_OUT pin must be properly terminated. A 49.9Ω 1% resistor can be used.

1.3 Dimensions

The following section shows mechanical drawings and dimensions.

Care must be taken to prevent shorts between exposed test points of the module and the host PCB.

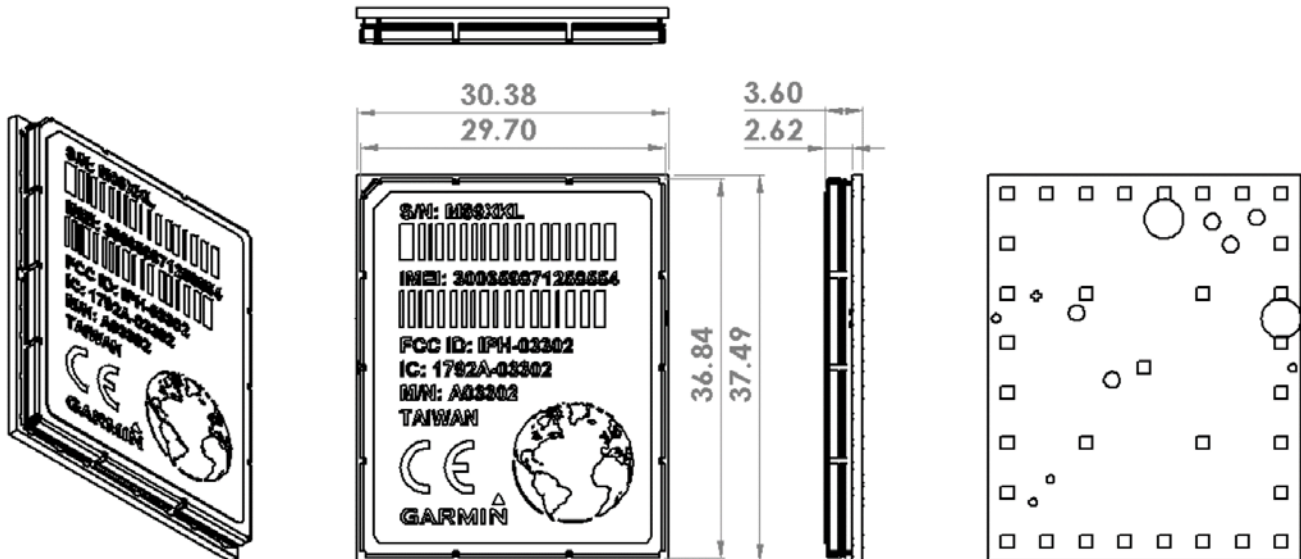

Figure 1: A03302 Module Dimensions

1.4 Transceiver Overview

The module utilizes a high power 2W RF power amplifier (RFPA) to support SBD satellite transmissions. The RFPA is powered from 5VDC supplied by the host and must be capable of supplying >1.54A (peak) with <40mVpp ripple. See section 2.1.1 for detailed host-supplied power requirements.

Note that the module does **not** support voice, circuit switched data, or SMS; **SBD ONLY**.

1.5 Key Features

- Surface mount POP design to interface to host PCB
- Full satellite communication SBD core solution
 - Requires power, antenna, and UART communication from host system
- 2-Way SBD satellite communication
- GNSS pass-through circuit for single antenna solution of both satellite communications and GNSS
- No SIM card required for SBD
- Maximum MO message size: 340 bytes
- Maximum MT message size: 270 bytes
- Confirmation that MO message is queued at the Gateway
- Global coverage
- FCC and IC tested to meet regulatory requirements; requiring antenna w/~3dBi of gain and proper power supply design

1.6 Firmware

This firmware must be used as-is, and no additional software can be added/removed.

2 System Requirements

2.1 Host Requirements

The host system must provide DC power (1.2V, 3.3V, 5V), (2) UARTs, and a satellite/GNSS antenna (GNSS optional).

Table 1: A03302 Module Pinout

Module Pin #	Schematic Name	Signal Level	Description
1	GND		
2	GND		
3	GPS_LNA_OUT		GNSS pass-through output to host
4	GND		
5	GND		
6	GND		
7	GND		

8	GND		
9	GND		
10	GND		
11	V_3.3V	3.3V	DC power input
12	V_1.2V	1.2V	DC power input
13	GND		
14	GND		
15	GND		
16	GPS_EN	3.3V	Enables V_3.3V_ON power to GPS LNA. Operates while rest of the module is powered off.
17	DP_S_TX	3.3V	Data port host transmit input (module in, host out)
18	TP_RX	3.3V	Test port module receive input (module in, host out)
19	TP_TX	3.3V	Test port module transmit output (module out, host in)
20	DP_S_RX	3.3V	Data port host receive output (module out, host in)
21	NETWORK_AVAILABLE	3.3V	Open drain output alert that a satellite can be seen. Also used as 90ms frame SYNC input during certification testing.
22	GND		
23	GND		
24	V_5.0V	5.0V	5V supply for RFPA. See detailed info in 2.1.1
25	GND		
26	ANTENNA		RF feed for GNSS input and satellite transceiver
27	GND		
28	V_3.3V_ON	3.3V	Always-on rail for GPS pass-through circuit
29	GND		
30	GND		
31	GND		
32	GND		
33	GND		

Table 2: Signal Level Requirements

Parameter	Symbol	MIN	TYP	MAX	Unit
Input High Voltage	VIH	2.0		5.5	V
Input Low Voltage	VIL	-0.3		0.8	V
Output High Voltage	VOH	2.4			V
Output Low Voltage	VOL			0.4	V
Low Level Output Current	IOL	4.4	6.9	8.4	mA
High Level Output Current	IOH	5.5	11.6	18.3	mA

SIGNAL NAMES ON MODULE

SUPPLIES AND SIGNALS
FROM HOST

GNSS/SAT ANTENNA	26	ANTENNA
GPS_LNA_OUT	3	GPS_LNA_OUT
GPS_EN	16	GPS_EN (INPUT, 3.3V) (KEEPS VFE_3.0V AND VLNA_3.0V ON)
UART1_ RX	17	DP_S_TX (INPUT, 3.3V)
UART1_ TX	20	DP_S_RX (OUTPUT, 3.3V)
UART2_ TX	19	TP_TX (OUTPUT, 3.3V)
UART2_ RX	18	TP_RX (INPUT, 3.3V)
NETWORK_AVAILABLE (TESTPOINT ONLY)	21	NETWORK_AVAILABLE (OUTPUT, 3.3V / INPUT, 5V, 11Hz SYNC)
V_5.0V	24	V_5.0V, 1.28A(RMS), 1.54A(PEAK) (SUPPLIES TX PA, VREF_3.0V AND VTX_3.0V REGULATORS)
V_3.3V_ON	28	V_3.3V_ON, 3mA(RMS), 3mA(PEAK) (SUPPLIES VFE_3.0V AND VLNA_3.0V REGULATOR)
V_3.3V	11	V_3.3V, 83mA(RMS), 683mA(PEAK) (SUPPLIES VDBB_3.3V, VRFA_3.3V, AND VFE_3.0V REGULATOR)
V_1.2V	12	V_1.2V, 38mA(RMS), 76mA(PEAK) (SUPPLIES VCORE_1.2V)
GND (MULTIPLE PADS)		GND (MULTIPLE POINTS)

Figure 2: Host-Module Electrical Requirements

2.1.1 Power Supply Requirements from Host

POWER SUPPLY BLOCK DIAGRAM

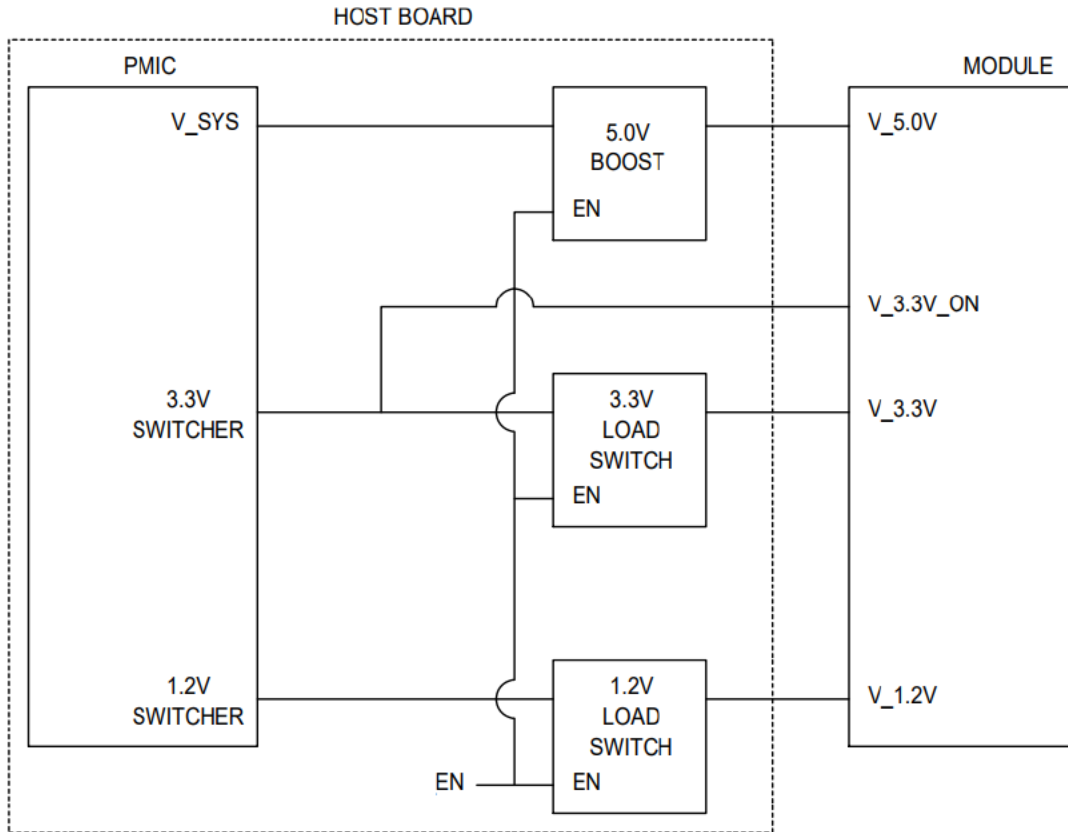

NOTES:

1. EN IS A GPIO FROM THE HOST PROCESSOR.
2. V_3.3V_ON SUPPLIES THE LDO THAT GENERATES VFE_3.0V AND VLNA_3.0V.

Figure 3: Power Supply Block Diagram

Table 3: Power Supply Requirements from Host

Voltage Rail	V _{MIN}	V _{TYP}	V _{MAX}	Current (RMS)	Current (PEAK)	Slew Rate	Notes
V_1.2V	1.08	1.20	1.32	38mA	76mA		Supplies DBB core
V3.3V_ON	2.97	3.30	3.63	3mA	3mA		Supplies GPS path-through circuit
V3.3V	2.97	3.30	3.63	83mA	683mA		Supplies I/O rail of V _{DBB} , all V _{RFA} and the 3V LDO enable for V _{FE} .
V_5.0V	4.50	5.00	5.50	1.28A	1.54A		Primarily for RFPA; also feeds V _{REF} and V _{TX} 3V LDOs. <40mVpp ripple.

POWER SUPPLY SEQUENCING:

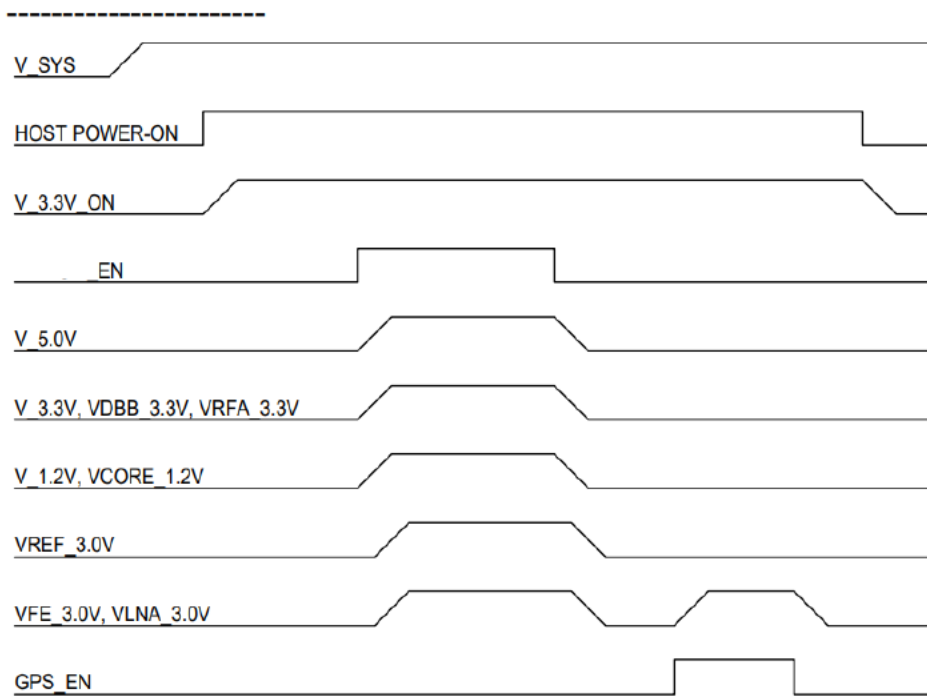

Figure 4: Power Supply Sequencing

Note that care must be taken to ensure the 5V supply can meet requirements over the full battery discharge cycle and across operating temperature. The 5V supply is critical for proper module operation and must guarantee the following specs:

- The 5V supply voltage droop during a 8.3ms transmission burst of up to 1.5A must be less than 200mV
- The supply should limit in-rush current to the module to 4A max
- The supply shall include over current protection against faults
- The supply noise should be less than the following limits:
 - 100 mVpp from 0 – 50 kHz
 - 5 mVpp at 1 MHz measured in 50 kHz bandwidth
 - 10 mVpp at 1 MHz measured in 1 MHz bandwidth
 - 5 mVpp above 5 MHz measured in 1 MHz bandwidth

The above are required to provide proper operation within the module's power supply regulation on the module itself.

2.2 A03302 Module Radio Specifications

The RFPA on every module is factory calibrated to 31.7dB +/- 0.5dB

Table 4: Satellite Communication Frequency Range

Parameter	Value
Frequency Range	1616 MHz – 1626.5 MHz
Duplexing Method	TDD (Time Domain Duplex)
Input/Output Impedance	50Ω
Multiplexing Method	TDMA/FDMA
Modulation	Differentially encoded QPSK

2.3 Antenna Requirements

Note the following guidelines for handling the antenna and pass-through connections of the module:

- Always terminate antenna feed with a suitable antenna or a 50Ω, 2W, RF load when the module is powered ON. Do not leave unterminated.
- GPS_LNA_OUT should be 50Ω terminated if not used. Can use a 49.9Ω 1% resistor.

Table 5: Satellite Communication Antenna Requirements

Parameter	Value	Notes
Impedance	50 Ω nominal	
VSWR	<1.5:1	
Gain	<3dBi	
Axial Ratio	< 2dB	
Polarization	RHCP	
Loss (including cable/connectors)	<3dB	

2.4 Operation

2.4.1 Power Cycling the Module

When not in use, the module should be powered off to save power. The exception being the always on V_3.3V_ON supply for GNSS. To properly shutdown the sat com portion of the module, a “flush memory” (AT*F) command must be sent by the host to ensure all memory write activity is complete. After the command is sent, wait 2 seconds before removing power. Likewise, to ensure all supplies have decayed adequately, wait 2 seconds before powering the module back on.

See the “ISU AT Command Reference” for a full set of AT commands and responses.

2.4.2 GNSS Pass-Through Feature

To simplify product integration, the A03302 module includes a GNSS pass-through circuit. This circuit includes a RF switch, pre-selector filter, LNA, and RF power splitter. During transmissions, the RF switch moves the antenna path from the receiver to the PA. During this time, there will be no antenna connection to the host GNSS front end. Note the signal loss resulting from the splitter.

3 Regulatory Approvals and Compliance for Garmin A03302 SBD Transceiver Module

3.1 Unauthorized Changes

Garmin has not approved any changes or modifications to this device by the user. Any changes or modifications could void the user's authority to operate the equipment.

3.2 Host Requirements

This module is limited to OEM installation ONLY. The OEM Integrator is responsible for ensuring that the end-user has no manual instructions to remove or install the module.

A host product manufacturer is responsible for ensuring compliance with the module(s) installed and fully operational. For example, if a host product was previously authorized as an unintentional radiator without containing a certified transmitter module, then a module is added, the host manufacturer is responsible for ensuring that the host continues to be compliant with unintentional radiator requirements after the module is installed and operational.

3.3 Radio Interference

This device complies with Part 15 of the FCC Rules and Industry Canada license-exempt RSS standard(s). Operation is subject to the following two conditions: (1) this device may not cause interference, and (2) this device must accept any interference, including interference that may cause undesired operation of the device.

Le présent appareil est conforme aux CNR d'Industrie Canada applicables aux appareils radio exempts de licence. L'exploitation est autorisée aux deux conditions suivantes : (1) l'appareil ne doit pas produire de brouillage, et (2) l'utilisateur de l'appareil doit accepter tout brouillage radioélectrique subi, même si le brouillage est susceptible d'en compromettre le fonctionnement.

This radio transmitter may only operate using an antenna of a maximum gain of 3 dBi. To reduce potential radio interference to other users, the antenna type and its gain should be so chosen that the equivalent isotropically radiated power (EIRP) is not more than that necessary for successful communication

3.4 RF Exposure

This module is limited to installation in mobile or fixed installations. This equipment complies with FCC and IC radiation exposure limits set forth for an uncontrolled environment. The antenna should be installed and operated with minimum distance of 24 cm between the radiator and your body. Antenna gain must not exceed: 3.0 dBi. This transmitter must not be co-located or operating in conjunction with any other antenna or transmitter.

3.5 FCC Class B Digital Device Notice

This equipment has been tested and found to comply with the limits for a Class B digital device, pursuant to part 15 of the FCC Rules. These limits are designed to provide reasonable protection against harmful interference in a residential installation. This equipment generates, uses and can radiate radio frequency energy and, if not installed and used in accordance with the instructions, may cause harmful interference to radio communications. However, there is no guarantee that interference will not occur in a particular installation. If this equipment does cause harmful interference to radio or television reception, which can be determined by turning the equipment off and on, the user is encouraged to try to correct the interference by one or more of the following measures:

- Reorient or relocate the receiving antenna.
- Increase the separation between the equipment and receiver.
- Connect the equipment into an outlet on a circuit different from that to which the receiver is connected.
- Consult the dealer or an experienced radio/TV technician for help.

3.6 Labelling Requirements for the Host device

The host device shall be properly labelled to identify the modules within the host device. The certification label of the module shall be clearly visible at all times when installed in the host device, otherwise the host device must be labelled to display the FCC ID and IC of the module, preceded by the words "Contains transmitter module", or the word "Contains", or similar wording expressing the same meaning, as follows:

Contains FCC ID: IPH-03302 or Contains transmitter module FCC ID: IPH-03302
Contains IC: 1792A-03302 or Contains transmitter module IC: 1792A-03302

The host OEM user manual must also contain clear instructions on how end users can find and/or access the module's IC and FCC ID.