

GARMIN[®]

GRID™ 20

INSTALLATION INSTRUCTIONS

Important Safety Information

⚠ WARNING

See the *Important Safety and Product Information* guide in the product box for product warnings and other important information.

When connecting the power cable, do not remove the in-line fuse holder. To prevent the possibility of injury or product damage caused by fire or overheating, the appropriate fuse must be in place as indicated in the product specifications. In addition, connecting the power cable without the appropriate fuse in place voids the product warranty.

⚠ CAUTION

Always wear safety goggles, ear protection, and a dust mask when drilling, cutting, or sanding.

NOTICE

When drilling or cutting, always check what is on the opposite side of the surface.

To obtain the best performance and to avoid damage to your boat, install the device according to these instructions.

Read all installation instructions before proceeding with the installation. If you experience difficulty during the installation, contact Garmin[®] Product Support.

Software Update

You must update the software when you install this device.

If your Garmin chartplotter has Wi-Fi[®] technology, you should update the software using the ActiveCaptain™ app on a compatible Android™ or Apple[®] device. If your chartplotter does not have Wi-Fi technology, you should update the software using a memory card and a Windows[®] computer.

For more information, go to support.garmin.com.

Tools Needed

- Drill and drill bits
- #2 Phillips screwdriver
- Jigsaw or rotary tool
- File and sandpaper
- Marine sealant (optional)

Mounting and Connection Considerations

NOTICE

This device should be mounted in a location that is not exposed to extreme temperatures or conditions. The temperature range for this device is listed in the product specifications. Extended exposure to temperatures exceeding the specified temperature range, in storage or operating conditions, may cause device failure. Extreme-temperature-induced damage and related consequences are not covered by the warranty.

The mounting surface must be flat to avoid damaging the device when it is mounted.

This device can be mounted in a dashboard or other surface using the included hardware. When selecting a mounting location, observe these considerations.

- To avoid interference with a magnetic compass, you must not mount the device closer to a compass than TBD.
- You must mount the device in a location that allows room for the routing and connection of the NMEA 2000[®] and power cable or the replacement of the batteries.
- To connect wirelessly, you must mount the device within 3 m (10 ft.) of the chartplotter.

Mounting the Device

NOTICE

Use only the included hardware when mounting this device. Using mounting hardware not provided with the device may damage the device.

Be careful when cutting the hole to flush mount the device. There is only a small amount of clearance between the case and the mounting holes, and cutting the hole too large could compromise the stability of the device after it is mounted.

If you are mounting the device on fiberglass with screws, it is recommended to use a countersink drill bit to drill a clearance counterbore through only the top gel-coat layer. This will avoid cracking in the gel-coat layer when the screws are tightened.

The included template and hardware can be used to mount the device at the selected location. The nut plates and machine screws allow you to more easily remove and replace the device when you need to change the batteries.

- 1 Trim the template and make sure it fits in the location where you want to mount the device.
- 2 Secure the template to the selected location.
- 3 Using a XX mm (⁹/₁₆ in.) drill bit, drill one or more of the holes inside the corners of the solid line on the template to prepare the mounting surface for cutting.
- 4 Using a jigsaw or rotary tool, cut the mounting surface along the **inside** of the solid line on the template.
- 5 If necessary, use a file and sandpaper to refine the size of the cutout.
- 6 After the device fits correctly in the cutout, ensure the mounting holes on the device line up with the larger 6 mm (¹/₄ in.) holes on the template.
- 7 If the mounting holes on the device do not line up, mark the new hole locations.
- 8 Using a 6 mm (¹/₄ in.) drill bit, drill the larger pilot holes.
- 9 Starting in one corner of the template, place a nut plate ① over the larger hole ② drilled in step 9.

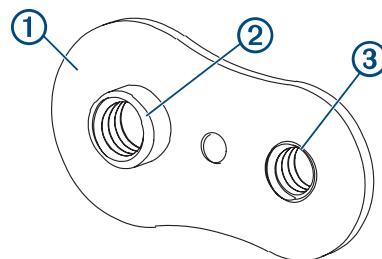

The smaller hole ③ on the nut plate should line up with the smaller 3.6 mm (⁹/₆₄ in.) hole on the template.

- 10 If the smaller hole on the nut plate does not line up with the smaller hole on the template, mark the new hole location.
- 11 Repeat for each nut plate.
- 12 Using a 3.6 mm (⁹/₆₄ in.) drill bit, drill the smaller holes.
- 13 Remove the template from the mounting surface.
- 14 Starting in one corner of the mounting location, place a nut plate ④ on the back of the mounting surface, lining up the large and small holes.

The raised portion of the nut plate should fit into the larger hole.

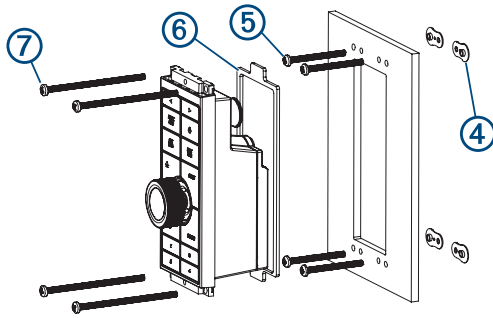

15 Secure the nut plate to the mounting surface by fastening an included M3 screw (5) through the smaller 3.6 mm (9/64 in.) hole.

16 Repeat for all 4 nut plates.

17 Install the foam gasket (6) on the back of the device.

The pieces of the foam gasket have adhesive on the back. Make sure you remove the protective liner before installing them on the device.

18 If you will not have access to the back of the device after you mount it, connect all necessary cables and install the AA batteries (observing polarity) as needed before placing the device into the cutout.

NOTE: To prevent corrosion of the metal contacts, if you are not using the cable, firmly press the weather cap over the connector.

19 Apply marine sealant between the mounting surface and the device to properly seal and prevent leakage behind the dashboard.

20 If you will have access to the back of the device, apply marine sealant around the cutout.

21 Place the device into the cutout.

22 Secure the device to the mounting surface using the included M4 screws (7) or wood screws, depending on the mounting method.

23 Carefully remove and discard the rubber protective bumper.

24 Wipe away all excess marine sealant.

25 Install the trim caps by snapping them in place around the top and bottom of the device.

NMEA 2000 Connection Considerations

NOTICE

If you are connecting this device to an existing NMEA 2000 network, the NMEA 2000 network should already be connected to power. Do not connect the NMEA 2000 power cable to an existing NMEA 2000 network, because only one power source should be connected to a NMEA 2000 network.

If you are connecting this device to an existing NMEA 2000 network or engine network by another manufacturer, you should install a NMEA 2000 Power Isolator (010-11580-00) between the existing network and the Garmin devices.

If you are installing a NMEA 2000 power cable, you must connect it to the boat ignition switch or through another in-line switch. NMEA 2000 devices will drain your battery if the NMEA 2000 power cable is connected to the battery directly.

The remote connects to a NMEA 2000 network on your boat, which provides power to the remote. The included NMEA 2000 cable allows you to either connect the device to your existing NMEA 2000 network.

If you need to create a NMEA 2000 network and are unfamiliar with it, go to support.garmin.com for more information.



| Item | Description |
|------|--|
| ① | GRID 20 |
| ② | Garmin chartplotter |
| ③ | Ignition or in-line switch |
| ④ | NMEA 2000 power cable |
| ⑤ | NMEA 2000 drop cable |
| ⑥ | 12 Vdc power source |
| ⑦ | NMEA 2000 terminator or backbone cable |
| ⑧ | NMEA 2000 T-connector |
| ⑨ | NMEA 2000 terminator or backbone cable |

Installing the Batteries

You can use AA alkaline, NiMH, or lithium batteries. Use NiMH or lithium batteries for best results.

- 1 Turn the D-ring counter-clockwise, and pull up to open the battery door.
- 2 Insert two AA batteries, observing polarity.



NOTE: You should verify the gasket and battery compartment are free of debris.

- 3 Close the battery door, and turn the D-ring clockwise.

Pairing the GRID Device with the Chartplotter from the Chartplotter

- 1 Select **Settings** > **System** > **Station Information** > **GRID™ Pairing** > **Add**.
- 2 On the GRID remote input device, press **SELECT**.

GRID 20 Specifications

| | |
|--------------------------------|---|
| Dimensions (W×H×D) | 77 × 174.8 × 60 mm (3 ¹ / ₁₆ × 6 ⁷ / ₈ × 2 ³ / ₈ in.) |
| Material | Fully gasketed, high-impact plastic, waterproof to IEC 60529 IPX7 standards |
| Water resistance | IEC 60529 IPX7* |
| Weight | 258 g (9.1 oz.) |
| Temperature range | From -15° to 70°C (from 5° to 158°F) |
| Battery type | Two AA batteries (alkaline, NiMH, or lithium) |
| Input power | 10 to 35 Vdc |
| Fuse | 7.5 A, 42 V fast-acting |
| Max. power usage at 10 Vdc | 2.8 W |
| Typical current draw at 12 Vdc | 100 mA |
| Max. current draw at 12 Vdc | 280 mA |
| Compass-safe distance | TBD |
| Wireless frequency/protocol | 2.4 GHz @ TBD dBm nominal |

*The device withstands incidental exposure to water of up to 1 m for up to 30 min. For more information, go to www.garmin.com/waterrating.

© 2018 Garmin Ltd. or its subsidiaries
Garmin® and the Garmin logo are trademarks of Garmin Ltd. or its subsidiaries,
registered in the USA and other countries. GRID™ is a trademark of Garmin Ltd. or its
subsidiaries. These trademarks may not be used without the express permission of
Garmin.

DRAFT

DRAFT

