

GARMIN Ltd. or its subsidiaries
c/o GARMIN International, Inc.
1200 E. 151st Street
Olathe, Kansas 66062 U.S.A.

FAA Approved AIRPLANE FLIGHT MANUAL SUPPLEMENT

**G1000 Integrated Avionics System and GFC 700 AFCS In
Hawker Beechcraft King Air 300/300LW Aircraft**

Dwg. Number: 190-00716-02 Rev. 1

This Supplement is Applicable to the Following Manuals:

101-590097-3
101-590097-107

This Supplement must be attached to the FAA Approved Airplane Flight Manual when the GARMIN G1000 Integrated Avionics System is installed in accordance with STC SA01535WI-D. The information contained herein supplements the information of the basic Airplane Flight Manual. For Limitations, Procedures, and Performance information not contained in this Supplement consult the basic Pilot's Operating Handbook and FAA Approved Airplane Flight Manual.

Airplane Serial Number: _____

Airplane Registration Number: _____

FAA Approved By:  _____

Robert G. Murray
ODA STC Unit Administrator
GARMIN International, Inc
ODA-240087-CE

Date: 5/11/2012

© Copyright 2012
GARMIN Ltd. or its subsidiaries
All Rights Reserved

Except as expressly provided herein, no part of this manual may be reproduced, copied, transmitted, disseminated, downloaded or stored in any storage medium, for any purpose without the express prior written consent of GARMIN. GARMIN hereby grants permission to download a single copy of this manual and of any revision to this manual onto a hard drive or other electronic storage medium to be viewed and to print one copy of this manual or of any revision hereto, provided that such electronic or printed copy of this manual or revision must contain the complete text of this copyright notice and provided further that any unauthorized commercial distribution of this manual or any revision hereto is strictly prohibited.

GARMIN International, Inc.
1200 E. 151st Street
Olathe, KS 66062 USA
Telephone: 913-397-8200
www.garmin.com

GARMIN International, Inc

Log of Revisions

Pilot's Operating Handbook and FAA Approved Airplane Flight Manual
Supplement for

G1000 Integrated Avionics System and GFC 700 AFCS In
Hawker Beechcraft King Air 300/300LW Aircraft

| REV NO. | PAGE NO(S) | DESCRIPTION | DATE OF APPROVAL | FAA APPROVED |
|---------|------------|----------------|------------------|--------------|
| 1 | ALL | Original Issue | See Cover | See Cover |
| | | | | |
| | | | | |
| | | | | |

This page intentionally left blank.

Table of Contents

| | |
|---|------------|
| Section 1 - General | 7 |
| Section 2 - Limitations | 15 |
| Section 3 - Emergency Procedures | 31 |
| Section 3A - Abnormal Procedures | 43 |
| Section 4 - Normal Procedures | 70 |
| Section 5 – Performance | 98 |
| Section 6 - Weight and Balance | 101 |
| Section 7 - Systems Description | 102 |
| Section 8 – Handling, Service, and Maintenance | 137 |

This page intentionally left blank.

Section 1 - General

The information in this supplement is FAA-approved material and must be attached to the Pilot's Operating Handbook and FAA Approved Airplane Flight Manual (POH/AFM) when the airplane has been modified by installation of the GARMIN G1000 Integrated Avionics System and GFC 700 Digital Automatic Flight Guidance System in accordance with GARMIN International, Inc. approved data.

The information in this supplement supersedes or adds to the basic POH/AFM only as set forth below. Users of the manual are advised to always refer to the supplement for possibly superseding information and placarding applicable to operation of the airplane.

The GARMIN G1000 system installed in the Hawker Beechcraft King Air 300 Aircraft provides a fully integrated Display, Communications, Navigation and Flight Control system. Functions provided by the G1000 system include: Primary Flight Information, Powerplant Monitoring, Navigation, Communication, Traffic Surveillance, TAWS Class A or B, Weather Avoidance, and a three-axis automatic flight control / flight director system with optional Electronic Stability & Protection.

USE OF THE HANDBOOK

The following definitions apply to WARNINGS, CAUTIONS and NOTES found throughout the handbook:

WARNING

Operating procedures, techniques, etc., which could result in personal injury or loss of life if not carefully followed.

CAUTION

Operating procedures, techniques, etc., which could result in damage to equipment if not carefully followed.

NOTE

Operating procedures, techniques, etc., which is considered essential to emphasize.

OPERATIONAL APPROVALS

G1000 GNSS (GPS/SBAS) NAVIGATION SYSTEM EQUIPMENT APPROVALS

The Garmin G1000 Integrated Avionics GNSS navigation system installed in this aircraft is a GPS system with a Satellite Based Augmentation System (SBAS) comprised of two TSO-C145a Class 3 approved Garmin GIA 63Ws, TSO-C146a Class 3 approved Garmin GDU 104X Display Units, GARMIN GA36 and GA37 antennas, and GPS software version 3.2 or later approved version. The G1000 GNSS navigation system in this aircraft is installed in accordance with AC 20-138A.

The Garmin G1000 Integrated Avionics GNSS navigation system as installed in this aircraft complies with the requirements of AC 20-138A and is approved for navigation using GPS and SBAS (within the coverage of a Satellite Based Augmentation System complying with ICAO Annex 10) for IFR en route, terminal area, and non-precision approach operations (including those approaches titled “GPS”, “or GPS”, and “RNAV (GPS)” approaches). The G1000 Integrated Avionics GNSS navigation system installed in this aircraft is approved for approach procedures with vertical guidance including “LPV” and “LNAV/VNAV”, within the U.S. National Airspace System.

The Garmin G1000 Integrated Avionics GNSS navigation system as installed in this aircraft complies with the equipment requirements of AC 90-105 and meets the equipment performance and functional requirements to conduct RNP terminal departure and arrival procedures and RNP approach procedures without RF (radius to fix) legs. Part 91 subpart K, 121, 125, 129, and 135 operators require a Letter of Authorization for operational approval from the FAA

The Garmin G1000 Integrated Avionics GNSS navigation system as installed in this aircraft complies with the equipment requirements of AC 90-100A for RNAV 2 and RNAV 1 operations. In accordance with AC 90-100A, Part 91 operators (except subpart K) following the aircraft and training guidance in AC 90-100A are authorized to fly RNAV 2 and RNAV 1 procedures. Part 91 subpart K, 121, 125, 129, and 135 operators require a Letter of Authorization for operational approval from the FAA.

The Garmin G1000 Integrated Avionics GNSS navigation system as installed in this aircraft has been found to comply with the requirements for primary means of Class II navigation in oceanic and remote navigation (RNP-10) without time limitations in accordance with AC 20-138A and FAA Order 8400.12A. The G1000 can be used without reliance on other long-range navigation systems. This does not constitute an operational approval.

The Garmin G1000 Integrated Avionics GNSS navigation system as installed in this aircraft has been found to comply with the navigation requirements for primary means of Class II navigation in oceanic and remote navigation (RNP-4) in accordance with AC 20-138A and FAA Order 8400.33. The G1000 can be used without reliance on other long-range navigation systems. Additional equipment may be required to obtain operational approval to utilize RNP-4 performance. This does not constitute an operational approval.

The Garmin G1000 Integrated Avionics GNSS navigation system as installed in this aircraft complies with the accuracy, integrity, and continuity of function, and contains the minimum system functions required for PRNAV operations in accordance with JAA Administrative & Guidance Material Section One: General Part 3: Temporary Guidance Leaflets, Leaflet No 10 (JAA TGL-10 Rev 1). The GNSS navigation system has two ETSO-145 / TSO-C145a Class 3 approved Garmin GIA 63Ws, and ETSO-146 / TSO-C146a Class 3 approved Garmin GDU 104X Display Units. The G1000 Integrated Avionics GNSS navigation system as installed in this aircraft complies with the equipment requirements for PRNAV and BRNAV operations in accordance with AC 90-96A and JAA TGL-10 Rev 1. This does not constitute an operational approval.

Garmin International holds an FAA Type 2 Letter of Acceptance (LOA) in accordance with AC 20-153 for database Integrity, quality, and database management practices for the Navigation database. Pilots and operators can view the LOA status at www.Garmin.com > Aviation Databases > Type 2 LOA Status.

Navigation information is referenced to WGS-84 reference system.

ELECTRONIC FLIGHT BAG

The G1000 Integrated Avionics System as installed in this aircraft supports approval of AC 120-76A Hardware Class 3, Software Type C Electronic Flight Bag (EFB) electronic aeronautical chart applications when using current FliteChart or ChartView data. Additional operational approvals may be required.

For operations under 14 CFR Part 91, it is suggested that a secondary or back up source of aeronautical information necessary for the flight be available to the pilot in the aircraft. The secondary or backup information may be either traditional paper-based material or displayed electronically. If the source of aeronautical information is in electronic format, operators must determine non-interference with the G1000 system and existing aircraft systems for all flight phases.

REDUCED VERTICAL SEPARATION MINIMUMS (RVSM)

This aircraft has been evaluated in accordance with 14 CFR Part 91, Appendix G, "Operations in Reduced Vertical Separation Minimum (RVSM) Airspace," and FAA Advisory Circular 91-85, "Authorization of Aircraft and Operators for Flight in Reduced Vertical Separation Minimums Airspace," and is qualified for RVSM operations as a group aircraft. This finding does not constitute approval to conduct RVSM operations.

ABBREVIATIONS AND TERMINOLOGY

The following glossary is applicable within the airplane flight manual supplement

| | |
|-----------------|---|
| AC | Advisory Circular |
| ADC | Air Data Computer |
| ADF | Automatic Direction Finder |
| AFCS | Automatic Flight Control System |
| AFM | Airplane Flight Manual |
| AFMS | Airplane Flight Manual Supplement |
| AGL | Above Ground Level |
| Ah | Amp hour |
| AHRS | Attitude and Heading Reference System |
| AIRAC | Aeronautical Information Regulation And Control |
| ALT | Altitude, or AFCS altitude hold mode, or ALT button on the GMC 710 AFCS Mode Controller |
| ALTS | AFCS altitude capture using the altitude in the altitude preselect window |
| ALTV | AFCS altitude capture using the altitude from the VNAV profile vertical constraint |
| AMMD | Airport Moving Map Display |
| AP | Autopilot |
| APR | AFCS Approach mode, or APR button of GMC 710 AFCS mode controller |
| APTSIGNS | Airport Signs (SVS softkey on the PFD) |
| APV | Approach with Vertical Guidance |
| ATC | Air Traffic Control |
| AUX | Auxiliary |
| BANK | Low-bank mode of the AFCS |
| BARO | Barometric Setting |
| BAT | Battery |
| BC | Back Course |
| BRNAV | Basic Area Navigation |
| BRT | Bright |
| CB | Circuit Breaker |
| CDI | Course Deviation Indicator |
| CFR | Code of Federal Regulations |
| CLR | Clear |
| COM | Communication radio |
| CRS | Course |
| CWS | Control Wheel Steering |

| | |
|----------------|--|
| DA | Decision Altitude |
| DC | Direct Current |
| DL LTNG | GFDS Data Link Lightning |
| DME | Distance Measuring Equipment |
| DN | Down |
| DR | Dead Reckoning |
| EC | Error Correction |
| EFB | Electronic Flight Bag |
| EIS | Engine Indication System |
| ELEC | Electrical |
| ENT | Enter |
| ESP | Electronic Stability and Protection |
| FAF | Final Approach Fix |
| FD | Flight Director |
| FLC | AFCS Flight Level Change mode, or FLC button on the GMC 710 AFCS mode controller |
| FLTA | Forward Looking Terrain Awareness |
| FMS | Flight Management System |
| FPM | Flight Path Marker or Feet Per Minute |
| FSB | Fasten Seat Belts |
| ft | Feet |
| ft/min | Feet/Minute |
| GA | Go-around |
| GCU | Garmin Control Unit |
| GDC | Garmin Air Data Computer |
| GDU | Garmin Display Unit |
| GEA | Garmin Engine/Airframe Unit |
| GEN | Generator |
| GEO | Geographic |
| GFC | Garmin Flight Control |
| GFDS | Garmin Flight Data Services |
| GIA | Garmin Integrated Avionics Unit |
| GMC | Garmin Mode Control Unit |
| GP | GPS Glide Path |
| GPS | Global Positioning System |
| GPWS | Ground Proximity Warning System |
| GRS | Garmin Reference System (AHRS) |

| | |
|-----------------------|---|
| GS | Glide Slope |
| GSA | Garmin Servo Actuator |
| GSR | Garmin Iridium Satellite Radio |
| HDG | AFCS heading mode or the HDG button on the GMC 710 AFCS Mode Controller |
| HITS | Highway in the Sky |
| HPa | Hectopascal |
| HSI | Horizontal Situation Indicator |
| IAF | Initial Approach Fix |
| IAP | Instrument Approach Procedure |
| IAS | Indicated Airspeed |
| ICAO | International Civil Aviation Organization |
| IFR | Instrument Flight Rules |
| ILS | Instrument Landing System |
| in-Hg | inches of mercury |
| INH | Inhibit |
| ITT | Interstage Turbine Temperature |
| KIAS | Knots Indicated Air Speed |
| LCD | Liquid Crystal Display |
| LDA | Localizer Type Directional Aid |
| LNAV | Lateral Navigation |
| LNAV + V | Lateral Navigation with Advisory Vertical Guidance |
| LNAV/VNAV | Lateral Navigation / Vertical Navigation |
| LOA | Letter of Acceptance |
| LOC | Localizer |
| LOI | Loss of Integrity (GPS) |
| LPV | Localizer Performance with Vertical Guidance |
| LRU | Line Replaceable Unit |
| LTNG | Lightning (XM Weather Product) |
| M | Mach |
| MAP | Missed Approach Point |
| MAXSPD | Maximum Speed, AFCS Overspeed Protection mode |
| MDA | barometric minimum descent altitude |
| MEL | Minimum Equipment List |
| MFD | Multi Function Display |
| MLS | Microwave Landing System |
| M_{Mo} | Maximum operation limit speed in mach |

| | |
|---------------|--|
| MNPS | Minimum Navigational Performance Specifications |
| MSL | Mean Sea Level |
| NAT | North Atlantic Track |
| NAV | Navigation, or AFCS navigation mode, or NAV button on the GMC710 AFCS Mode Controller |
| NEXRAD | Next Generation Radar (XM Weather Product) |
| NM | Nautical Mile |
| NPA | Non-precision Approaches |
| OAT | Outside Air Temperature |
| OBS | Omni Bearing Selector |
| OVR | Override |
| P/N | Part Number |
| PDA | Premature Descent Alert |
| PFD | Primary Flight Display |
| PFT | Pre-Flight Test |
| PIT | AFCS pitch mode |
| POH | Pilot's Operating Handbook |
| PRNAV | Precision Area Navigation |
| PROC | Procedure button on the GDU or GCU 477 |
| PSI | Pounds per Square Inch |
| PTCH | Pitch |
| RA | Radar Altimeter, or Radar Altitude, or traffic Resolution Advisory |
| RNAV | Area Navigation |
| RNP | Required Navigation Performance |
| ROL | AFCS roll mode |
| RPM | Revolutions per Minute |
| RVSM | Reduced Vertical Separation Minimums |
| SBAS | Satellite Based Augmentation System |
| SDF | Simplified Directional Facility |
| SID | Standard Instrument Departure |
| SPD | Speed button on the GMC 710 AFCS Mode Controller. Toggles the FLC speed between Mach and IAS references. |
| STAR | Standard Terminal Arrival Route |
| STBY | Standby |
| STC | Supplemental Type Certificate |
| STD | Standard |
| SUSP | Suspend |

| | |
|-----------------------|--|
| SVS | Synthetic Vision System |
| SYN TERR | Synthetic Terrain softkey |
| SYN VIS | Synthetic Vision softkey |
| TA | Traffic Advisory |
| TAWS | Terrain Awareness and Warning System |
| TCAS | Traffic Alert and Collision Avoidance System |
| TEMP | Temperature |
| TIS | Traffic Information System |
| TMR | Timer |
| TO | Take off |
| TOD | Top of Descent |
| TSO | Technical Standard Order |
| VAPP | AFCS VOR Approach Mode |
| VCO | Voice Call Out |
| Vdc | Volts DC |
| VDP | Visual Descent Point |
| VFR | Visual Flight Rules |
| VHF | Very High Frequency |
| VMC | Visual Meteorological Conditions |
| V_{MO} | Maximum operation limit speed in knots |
| VNAV | Vertical Navigation |
| VNV | Vertical Navigation button on the GMC 710 AFCS Mode Controller |
| VOR | VHF Omni-directional Range |
| VPTH | Vertical path |
| VS | Vertical Speed |
| WAAS | Wide Area Augmentation System |
| WFDE | WAAS Fault Detection/Exclusion |
| WGS-84 | World Geodetic System – 1984 |
| WSHLD | Windshield |
| XFR | Transfer button on the GMC 710 AFCS Mode Controller |
| XM | XM satellite system |
| XPDR | Transponder |
| YD | Yaw Damper |

Section 2 - Limitations

INTRODUCTION

The G1000 Cockpit Reference Guide for Hawker Beechcraft King Air 300/B300 series, GARMIN part number 190-01344-00 Revision A or later, must be immediately available to the flight crew during all phases of flight.

AIRSPEED LIMITATIONS AND INDICATOR MARKINGS

No changes were made to the airplane's airspeed limitations. The airspeed indicators on the Primary Flight Displays (PFDs) and the standby airspeed indicator are marked in accordance with the airplane's POH/AFM.

A red low speed awareness band is marked on the PFDs in red from 20 – 81 KIAS. The low-speed awareness band is suppressed while the airplane is on the ground. The low-speed awareness band appears in flight two seconds after main gear liftoff.

The standby airspeed indicator is marked in accordance with the airspeed markings called out in the airplane's AFM/POH. The standby airspeed indicator is not marked with a low speed awareness band.

POWER PLANT LIMITATIONS AND INDICATOR MARKINGS

No changes were made to the airplane's engine operating limits. The engine gauges are marked as shown in the following table. Refer to the latest Airplane Flight Manual or appropriate Airplane Flight Manual Supplement for engine and propeller limitations.

NOTE

The gauge indicator pointer and digital display will flash inverse red/white video for 5 seconds, then remain steady red, if the indicated engine parameter exceeds its established limit. The gauge indicator digital display will change to yellow for "caution" conditions.

| OPERATING PARAMETER | PT6A-60A ENGINES COLOR MARKINGS & RANGES | | | |
|----------------------------------|--|-----------------------|-------------------------|-----------------------------------|
| | Red Arc/Radial (Minimum Limit) | Green Arc (Normal) | Yellow Arc (Caution) | Red Arc/Radial (Maximum Limit) |
| Torquemeter (%) | -- | 0 to 100 (a) | -- | 100 (b) |
| ITT (°C) | -- | 400 to 820 (c) | -- | 820 (d)(e) |
| Prop N ₂ (rpm) | -- | 1050 to 1700 | -- | 1700 |
| Gas Generator N ₁ (%) | -- | 62 to 104 | -- | 104 |
| Oil Temperature. (°C) (g) | -- | 0 to 99 | -- | 99 |
| Oil Pressure (psi) (f) | 60 | 90 to 135 | 60 to 90 | 135 |

Footnotes:

- (a) Torque limit applies within range of 1000 - 1700 propeller rpm (N₂).
- (b) Torque indications between 100% and 156% are time limited to 20 seconds.
- (c) Maximum ITT during idle is 750°C. High ITT at ground idle may be corrected by reducing accessory load and/or increasing N₁ rpm.
- (d) ITT indication between 820°C and 850°C is time limited to 20 seconds.
- (e) ITT starting limit at 1000°C (red triangle) is time limited to 5 seconds.
- (f) Normal oil pressure is 90 to 135 psig at gas generator speeds above 72%. With engine torque below 62%, minimum oil pressure is 60 psig at normal oil temperature (60° to 70°C). Oil pressures under 90 psi are undesirable. Under emergency conditions, to complete a flight, a lower oil pressure limit of 60 psig is permissible at a reduced power level not exceeding 62% torque. Oil pressures below 60 psig are unsafe and require that either the engine be shut down or a landing be made at the nearest suitable airport, using the minimum power required to sustain flight. Fluctuations of plus or minus 10 psi are acceptable.
During extremely cold starts, oil pressure may reach 200 psi (red triangle). In flight, oil pressures above 135 psi but not exceeding 200 psi are permitted only for the duration of the flight.
- (g) Oil temperature limits are -40°C and +110 °C. However, temperatures between 99°C and 110 °C are limited to a maximum of 10 minutes.

MANEUVER LIMITS

No changes have been made to the aircraft's maneuver limits. The Hawker Beechcraft Super King Air 300 is a Normal Category airplane. Acrobatic maneuvers, including spins, are prohibited.

OPERATIONS IN RVSM AIRSPACE

The airplane is not permitted to operate in RVSM airspace if the static ports are damaged, or if damage or surface irregularities are found within the RVSM critical region.

The pilot and copilot PFDs must display the on-side ADC information for operations in RVSM airspace.

G1000 INTEGRATED AVIONICS SYSTEM

The GARMIN G1000 Cockpit Reference Guide P/N 190-01344-00, Rev A, or later FAA accepted revision, must be immediately available to the flight crew during all phases of flight.

Tuning of the COM and NAV radios using the GCU477 controller must be done from the left seat pilot's station and only referencing the pilot's PFD.

Required flight crewmembers must wear and use headsets when the overhead cockpit speaker audio is selected OFF.

Do not take off unless all display units are installed and operational.

Do not take off with any display in reversionary mode.

Do not take off with any of the following messages displayed in the ALERTS window:

| | |
|--|--------------|
| GPS1 FAIL and GPS2 FAIL simultaneously | PFD1 SERVICE |
| GPS NAV LOST | PFD2 SERVICE |
| GIA1 SERVICE | GMA1 SERVICE |
| GIA2 SERVICE | GMA2 SERVICE |
| MFD SERVICE | GEO LIMITS |

Operation of the G1000 system is prohibited if the PFD1 FAN FAIL, PFD2 FAN FAIL or MFD FAN FAIL is displayed in the ALERTS window **AND** the Outside Air Temperature is greater than 41°C (106°F) **AND** cabin air conditioning is inoperative.

Do not takeoff if GIA1 FAN FAIL or GIA2 FAN FAIL is displayed in the ALERTS window **AND** the Outside Air Temperature is greater than 42°C (107°F).

Ground operation of the G1000 system is not allowed when the Outside Air Temperature is greater than 47°C (116°F) **AND** cabin air conditioning is inoperative.

The G1000 system must be turned on and operated for at least 30 minutes before takeoff if ground outside air temperature is -40°C (-40°F) or below.

Use of VNAV is prohibited during the intermediate segment of an approach that includes a teardrop course reversal. VNAV will become 'Unavailable' at the beginning of the teardrop segment of the course reversal.

The fuel quantity, fuel required, fuel remaining, and gross weight estimate functions of the G1000 are supplemental information only and must be verified by the flight crew.

Do not use SafeTaxi or Chartview functions as the basis for ground maneuvering. SafeTaxi and Chartview functions do not comply with the requirements of AC 20-159 and are not qualified to be used as an airport moving map display (AMMD). SafeTaxi and Chartview are to be used by the flight crew to orient themselves on the airport surface to improve pilot situational awareness during ground operations.

The use of the colors red and amber within the checklist function has not been evaluated or approved by this STC. Use of the colors red and/or amber within user created checklists may require separate evaluation and approval by the FAA

G1000 GNSS (GPS/SBAS) NAVIGATION SYSTEM LIMITATIONS

NOTE

Limitations are in bolded text for this section only

The pilot must confirm at system initialization that the Navigation database is current.

Navigation database is expected to be current for the duration of the flight. **If the AIRAC cycle will change during flight, the pilot must ensure the accuracy of navigation data, including suitability of navigation facilities used to define the routes and procedures for flight. If an amended chart affecting navigation data is published for the procedure, the database must not be used to conduct the procedure.**

GPS/SBAS based IFR enroute, oceanic, and terminal navigation is prohibited unless the pilot verifies and uses a valid, compatible, and current Navigation database or verifies each waypoint for accuracy by reference to current approved data.

Discrepancies that invalidate a procedure should be reported to Garmin International. **The affected procedure is prohibited from being flown using data from the Navigation database until a new Navigation database is installed in the aircraft and verified that the discrepancy has been corrected.** Contact information to report Navigation database discrepancies can be found at www.Garmin.com>Support>Contact Garmin Support>Aviation. Pilots and operators can view navigation data base alerts at www.Garmin.com > In the Air> NavData Alerts.

For flight planning purposes, in areas where SBAS coverage is not available, the pilot must check RAIM availability. Within the United States, RAIM availability can be determined using the G1000 WFDE Prediction program, part number 006-A0154-01 (010-G1000-00) or later approved version with GARMIN GA36 and GA37 antennas selected, or the FAA's en route and terminal RAIM prediction website: www.raimprediction.net, or by contacting a Flight Service Station. Within Europe, RAIM availability can be determined using the G1000 WFDE Prediction program or Europe's AUGER GPS RAIM Prediction Tool at <http://augur.ecacnav.com/augur/app/home>. For other areas, use the G1000 WFDE Prediction program. This requirement is not necessary if SBAS coverage is confirmed to be available along the entire route of flight. The route planning and WFDE prediction program may be downloaded from the GARMIN G1000 website on the internet. For information on using the WFDE Prediction Program, refer to GARMIN WAAS FDE Prediction Program, part number 190-00643-01, 'WFDE Prediction Program Instructions'.

For flight planning purposes, operations within the U.S. National Airspace System on RNP and RNAV procedures when SBAS signals are not available, the availability of GPS integrity RAIM shall be confirmed for the intended route of flight. In the event of a predicted continuous loss of RAIM of more than five minutes for any part of the intended route of flight, the flight should be delayed, canceled, or re-routed on a track where RAIM requirements can be met.

For flight planning purposes for operations within European B-RNAV and P-RNAV airspace, if more than one satellite is scheduled to be out of service, then the availability of GPS integrity

RAIM shall be confirmed for the intended flight (route and time). In the event of a predicted continuous loss of RAIM of more than five minutes for any part of the intended flight, the flight should be delayed, canceled, or re-routed on a track where RAIM requirements can be met.

For flight planning purposes, operations where the route requires Class II navigation the aircraft's operator or flight crew must use the Garmin WFDE Prediction program to demonstrate that there are no outages on the specified route that would prevent the G1000 from providing primary means of Class II navigation in oceanic and remote areas of operation that requires (RNP-10 or RNP-4) capability. If the Garmin WFDE Prediction program indicates fault exclusion (FDE) is unavailable for more than 34 minutes in accordance with FAA Order 8400.12B for RNP-10 requirements, or 25 minutes in accordance with FAA Order 8400.33 for RNP-4 requirements, then the operation must be rescheduled when FDE is available.

Both GIA 63Ws GPS navigation receivers must be operating and providing GPS navigation guidance to their respective PFD for operations requiring RNP-4 performance.

North Atlantic (NAT) Minimum Navigational Performance Specifications (MNPS) Airspace operations per AC 91-49 and AC 120-33 require both GPS/SBAS receivers to be operating and receiving usable signals except for routes requiring only one Long Range Navigation sensor. Each display computes an independent navigation solution based on the on-side GPS sensor. However, either display will automatically revert to the cross-side sensor if the on-side sensor fails or if the cross-side sensor is determined to be more accurate. A "BOTH ON GPS1" or "BOTH ON GPS2" message does not necessarily mean that one GPS has failed. Refer to the MFD AUX-GPS STATUS page to determine the state of the unused GPS.

Whenever possible, RNP and RNAV routes including Standard Instrument Departures (SIDs) and Obstacle Departure Procedures (ODPs), Standard Terminal Arrival (STAR), and enroute RNAV "Q" and RNAV "T" routes should be loaded into the flight plan from the database in their entirety, rather than loading route waypoints from the database into the flight plan individually. Selecting and inserting individual named fixes from the database is permitted, provided all fixes along the published route to be flown are inserted. **Manual entry of waypoints using latitude/longitude or place/bearing is prohibited.**

"GPS", "or GPS", and "RNAV (GPS)" instrument approaches using the G1000 System are prohibited unless the pilot verifies and uses the current Navigation database. GPS based instrument approaches must be flown in accordance with an approved instrument approach procedure that is loaded from the Navigation database.

Not all published Instrument Approach Procedures (IAP) are in the Navigation database. **Pilots planning on flying an RNAV instrument approach must ensure that the Navigation database contains the planned RNAV Instrument Approach Procedure and that approach procedure must be loaded from the Navigation database into the FMS flight plan by its name.**

IFR non-precision approach approval using the GPS/SBAS sensor is limited to published approaches within the U.S. National Airspace System. Approaches to airports in other airspace are not approved unless authorized by the appropriate governing authority.

When operating under instrument flight rules, flight plan selection of any required alternate airport must not be based on an RNAV (GPS) LP/LPV or LNAV/VNAV approach. Alternate airport selection must be based upon an LNAV approach or an available ground-based approach for which the aircraft is equipped to fly.

The navigation equipment required to join and fly an instrument approach procedure is indicated by the title of the procedure and notes on the IAP chart. **Use of the GARMIN G1000 GPS/SBAS receivers to provide navigation guidance during the final approach segment of an ILS, LOC, LOC-BC, LDA,**

SDF, MLS or any other type of approach not approved for “or GPS” navigation is prohibited. When using the G1000 VOR/LOC/GS receivers to fly the final approach segment, VOR/LOC/GS navigation data is must be selected and presented on the CDI of the pilot flying.

Navigation information is referenced to WGS-84 reference system, and should only be used where the Aeronautical Information Publication (including electronic data and aeronautical charts) conform to WGS-84 or equivalent.

AHRS AREAS OF OPERATION

The GARMIN G1000 system is not designed for use as a polar navigator. Operation outside the approved operating area is prohibited. Refer to Figure 1. Flight operations with the G1000 Integrated Avionics installed are prohibited in the following regions due to unsuitability of the Earth's magnetic fields:

1. In the Northern hemisphere, North of the line beginning at:

N069°48'57.14"W180°00'00.00" to
N067°09'04.64"W180°00'00.00" to
N067°09'04.64"W151°00'00.00" to
N060°34'40.96"W123°00'00.00" to
N054°43'13.96"W123°00'00.00" to
N054°43'13.96"W094°30'00.00" to
N054°43'13.96"W065°30'00.00" to
N060°03'03.37"W065°30'00.00" to
N067°13'16.31"W038°00'00.00" to
N067°13'16.31"W007°00'00.00" to
N069°52'01.37"W007°00'00.00" to
N069°52'01.37"W007°00'00.00" to
N069°52'01.37"E026°30'00.00" to
N065°49'54.43"E026°30'00.00" to
N065°49'54.43"E057°00'00.00" to
N060°59'40.52"E057°00'00.00" to
N060°59'40.52"E086°30'00.00" to
N060°59'40.52"E118°00'00.00" to
N062°30'03.55"E118°00'00.00" to
N062°30'03.55"E147°00'00.00" to
N068°00'43.26"E147°00'00.00" to
N068°00'43.26"E180°00'00.00" to
N069°48'57.15"E180°00'00.00" to point of beginning;

2. In the Southern hemisphere, South of the line beginning at:

S070°00'00.00"W180°00'00.00" to
S070°00'00.00"E097°00'00.00" to
S047°00'00.00"E097°00'00.00" to
S047°00'00.00"E155°00'00.00" to
S053°00'00.00"E155°00'00.00" to
S053°00'00.00"E180°00'00.00" to point of beginning

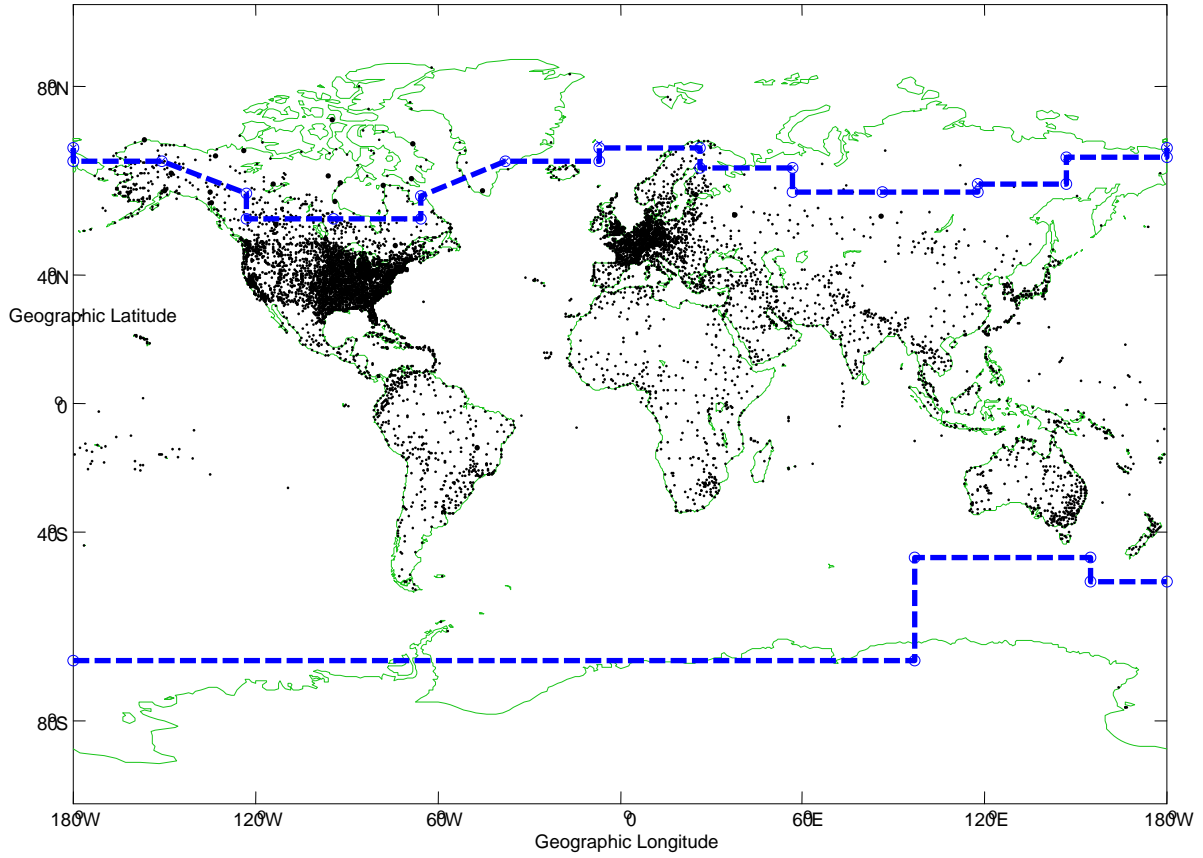

Figure 1, GRS 77 Geographic Limits

AUTOPILOT OPERATION LIMITS

One pilot must remain seated at the controls, with seatbelt fastened, during all autopilot operations.

Do not use autopilot or yaw damper during takeoff and landing.

The GFC 700 AFCS preflight test must complete successfully prior to use of the autopilot, flight director or manual electric trim.

The maximum fuel imbalance with the autopilot engaged is 300 pounds.

Minimum speed for autopilot operation is 100 KIAS.

Maximum speed limit for autopilot operation is unchanged from the airplane's maximum airspeed limit (V_{MO}/M_{MO}).

Autopilot coupled ILS, LOC, LPV, or LNAV/VNAV approaches with the yaw damper inoperative or not engaged is prohibited.

Do not use autopilot below the following altitudes:

1. On takeoff, do not engage the autopilot below 400 feet AGL
2. Cruise 1000 feet AGL
3. Approach (GP or GS mode) 200 feet AGL
4. Approach (FLC, VS, PIT or ALT mode) Higher of 400 feet AGL or Approach MDA

SYNTHETIC VISION AND PATHWAYS LIMITS

Use of the Synthetic Vision system display elements alone for aircraft control without reference to the G1000 primary flight instruments or the aircraft standby instruments is prohibited.

Use of the Synthetic Vision system alone for navigation, or obstacle or terrain avoidance is prohibited.

Use of the SVS traffic display alone to avoid other aircraft is prohibited.

TAWS, GPWS, AND TERRAIN SYSTEM LIMITS

Pilots are authorized to deviate from their current ATC clearance to the extent necessary to comply with TAWS or GPWS warnings.

The TAWS databases have an area of coverage as detailed below:

1. The terrain database coverage area is from North 75° Latitude to South 60° Latitude in all longitudes.
2. The Airport Terrain Database coverage area includes airports from North 75° Latitude to South 60° Latitude in all longitudes.
3. The Obstacle Database coverage area includes the United States and Europe.

Use of the TAWS or GPWS for navigation or terrain and/or obstacle avoidance is prohibited.

NOTE

The TAWS page and terrain display is intended to serve as a situational awareness tool only. It may not provide the accuracy, fidelity, or both, on which to solely base decisions and plan maneuvers to avoid terrain or obstacles.

To avoid unwanted alerts, TAWS and/or GPWS should be inhibited when landing at an airport that is not included in the airport database.

TRAFFIC AVOIDANCE SYSTEM LIMITS

Use of the MAP - TRAFFIC MAP to maneuver the airplane for traffic avoidance without outside visual reference is prohibited. The Traffic Information System (TIS) or optional Skywatch HP, Skywatch TAS, Honeywell KTA-870 TAS, Garmin GTS 820/850 TAS, or Collins TCAS-94 or TCAS-4000 Systems are intended as an aid for the pilot to visually locate traffic. It is the responsibility of the pilot to see and manually maneuver the airplane to avoid other traffic. Maneuvers based solely on a traffic advisory (TA) or on information displayed on a traffic display are not authorized.

For airplanes that have a Collins TCAS-94 or TCAS-4000 TCAS II system installed, pilots are authorized to deviate from their current ATC clearance to comply with a TCAS II resolution advisory (RA).

DATA LINK WEATHER (XM OR GFDS WEATHER)

Datalink weather information displayed by the G1000 system is limited to supplemental use only. XM or Garmin Flight Data Service (GFDS) weather data is not a source of official weather information. Use of the NEXRAD, PRECIP, XM LTNG and DL LTNG (Datalink Lightning) data on the MAP – NAVIGATION MAP, MAP – XM WEATHER DATA LINK or MAP – GFDS WEATHER DATA LINK pages for hazardous weather, e.g., thunderstorm penetration is prohibited.

NEXRAD, PRECIP, XM LTNG and DL LTNG information on the MAP – NAVIGATION, MAP – XM WEATHER DATA LINK, or MAP – GFDS WEATHER DATA LINK pages is intended only as an aid to enhance situational awareness of hazardous weather, not penetration. It is the pilot's responsibility to avoid hazardous weather using official weather data sources and the airplane's in-flight weather radar.

OPTIONAL L3 COMMUNICATIONS AVIONICS SYSTEM WX-500 STORMSCOPE

Stormscope lightning information displayed by the G1000 system is limited to supplemental use only. The use of the Stormscope lightning data on the MAP – NAVIGATION MAP and/or MAP – STORMSCOPE page for hazardous weather (thunderstorm) penetration is prohibited. Stormscope lightning data on the MAP - NAVIGATION or MAP – STORMSCOPE page is intended only as an aid to enhance situational awareness of hazardous weather, not penetration. It is the pilot's responsibility to avoid hazardous weather using official weather data sources and the airplane's weather radar.

PLACARDS

On Instrument Panel above the Standby Attitude Indicator:

| STANDBY ALT/AS | |
|------------------|-----------------------|
| ALTITUDE – FEET | V _{MO} -KIAS |
| S.L TO 21,000 | 259 |
| 21,000 TO 25,000 | 239 |
| 25,000 TO 30,000 | 214 |
| ABOVE 30,000 | 191 |

KINDS OF OPERATION LIMITS

The Hawker Beechcraft King Air 300 is approved for the following types of operations when the required equipment, as shown in the airplane AFM/POH Kinds of Operations Equipment List, supplemented by the Kinds of Operations Equipment List from other applicable Airplane Flight Manual Supplements, and the Kinds of Operations Equipment List contained in this Airplane Flight Manual Supplement, is installed and operable.

1. VFR Day
2. VFR Night
3. IFR Day
4. IFR Night
5. Icing Conditions

KINDS OF OPERATIONS EQUIPMENT LIST

This airplane may be operated in day or night VFR, day or night IFR, and icing conditions when the required systems and equipment are installed and operable.

The following equipment list identifies the systems and equipment upon which type certification for each kind of operation was predicated. The system and equipment listed must be installed and operable for the particular kind of operation indicated unless:

The airplane is approved to be operated in accordance with a current Minimum Equipment List (MEL) issued by the FAA.

Or:

An alternate procedure is provided in the Pilots Operating Handbook and FAA Approved Flight Manual for the inoperative state of the listed system or equipment and all limitations are complied with.

Numbers in the Kinds of Operations Equipment List refer to quantities required to be operative for the specified condition. The list does not include all equipment that may be required by specific operating rules. It also does not include components obviously required for the airplane to be airworthy such as wings, empennage, engines, etc.

| System and/or Equipment | VFR | | IFR | | Icing Conditions | Remarks and/or Exceptions |
|---|-----|-------|-----|-------|---------------------|-------------------------------|
| | Day | Night | Day | Night | | |
| ELECTRICAL POWER | | | | | | |
| Inverter | 0 | 0 | 0 | 0 | 0 | Removed by G1000 modification |
| INVERTER Annunciator | 0 | 0 | 0 | 0 | 0 | Removed by G1000 modification |
| Standby Battery | 0 | 1 | 1 | 1 | 1 | |
| ENGINE INDICATIONS No Changes - Refer to Aircraft Flight Manual | | | | | | |
| ENGINE OIL No Changes - Refer to Aircraft Flight Manual | | | | | | |
| ENVIRONMENTAL No Changes - Refer to Aircraft Flight Manual | | | | | | |
| EQUIPMENT/FURNISHINGS No Changes - Refer to Aircraft Flight Manual | | | | | | |
| FIRE PROTECTION No Changes - Refer to Aircraft Flight Manual | | | | | | |
| FLIGHT CONTROLS No Changes - Refer to Aircraft Flight Manual | | | | | | |
| FUEL No Changes - Refer to Aircraft Flight Manual | | | | | | |
| ICE AND RAIN PROTECTION No Changes - Refer to Aircraft Flight Manual | | | | | | |
| LANDING GEAR No Changes - Refer to Aircraft Flight Manual | | | | | | |
| LIGHTS No Changes - Refer to Aircraft Flight Manual | | | | | | |
| MISCELLANEOUS EQUIPMENT (Single Pilot Operation Only) No Changes - Refer to Aircraft Flight Manual | | | | | | |

| System and/or Equipment | VFR Day | VFR Night | IFR Day | IFR Night | Icing Conditions | Remarks and/or Exceptions |
|--|---------|-----------|---------|-----------|------------------|---|
| | | | | | | |
| NAVIGATION INSTRUMENTS | | | | | | |
| Magnetic Compass | 1 | 1 | 1 | 1 | 1 | |
| Outside Air Temperature | 1 | 1 | 1 | 1 | 1 | |
| G1000 Integrated Avionics | | | | | | |
| GARMIN G1000 Cockpit Reference Guide | 1 | 1 | 1 | 1 | 1 | |
| Autopilot | 0 | 0 | 1 | 1 | 0 | Required only for operations in RVSM airspace. |
| Electronic Stability & Protection (ESP) | 0 | 0 | 0 | 0 | 0 | |
| Yaw Damper/Rudder Boost System | 1 | 1 | 1 | 1 | 1 | Yaw damper is required for flight above a certain altitude. Refer to Aircraft's POH or AFMS for any installed modifications that affect this requirement. Rudder Boost is required for all flights. |
| Control Wheel Autopilot Disconnect/Trim Interrupt Switches | 1 | 1 | 1 | 1 | 1 | Left side is required. Both sides required for two-crew operation. |
| VHF Communications System | 0 | 0 | 1 | 1 | 1 | Or as required by operating regulation. |
| Audio Control Panel | 1 | 1 | 1 | 1 | 1 | Pilot's audio panel required for single pilot operation. Both sides required for two-crew operation. |
| Primary Flight Display | 2 | 2 | 2 | 2 | 2 | |
| Multi Function Display | 1 | 1 | 1 | 1 | 1 | |
| Air Data Computer | 2 | 2 | 2 | 2 | 2 | |
| Attitude/Heading Reference System (AHRS) | 2 | 2 | 2 | 2 | 2 | |
| Standby Attitude Indicator | 0 | 0 | 1 | 1 | 1 | |
| Standby Altimeter | 1 | 1 | 1 | 1 | 1 | |
| Standby Airspeed Indicator | 1 | 1 | 1 | 1 | 1 | |
| ATC Transponder | 0 | 0 | 1 | 1 | 1 | Required for RVSM operations, or as required by operating regulation. |
| VHF Navigation Receiver | 0 | 0 | 0 | 0 | 0 | Or as required by operating regulation. |
| GPS/SBAS Receiver | 1 | 1 | 2 | 2 | 2 | Or as required by operating regulation. |
| Automatic Direction Finder (ADF) | 0 | 0 | 0 | 0 | 0 | Or as required by operating regulation. |
| Distance Measuring Equipment (DME) | 0 | 0 | 0 | 0 | 0 | Or as required by operating regulation. |
| Radar (Radio) Altimeter | 0 | 0 | 0 | 0 | 0 | Or as required by operating regulation. |

| System and/or Equipment | VFR Day | | | | | Remarks and/or Exceptions | |
|---|-----------|---|-----------|-----------|------------------|--|-----------|
| | VFR Night | | | | Icing Conditions | | |
| | IFR Day | | | IFR Night | | | |
| | IFR Night | | IFR Night | | | | |
| | IFR Night | | | | | | IFR Night |
| | IFR Night | | | | | | |
| Marker Beacon Receiver | 0 | 0 | 0 | 0 | 0 | Or as required by operating regulation. | |
| Terrain Awareness and Warning System (TAWS) | 0 | 0 | 0 | 0 | 0 | Or as required by operating regulation. | |
| Ground Proximity Warning System (GPWS) | 0 | 0 | 0 | 0 | 0 | Or as required by operating regulation. | |
| Weather Radar | 0 | 0 | 0 | 0 | 0 | Or as required by operating regulation. | |
| XM or GFDS Datalink Weather | 0 | 0 | 0 | 0 | 0 | | |
| GSR 56 Satellite Receiver | 0 | 0 | 0 | 0 | 0 | | |
| GDU Cooling Fans (3 total) | 2 | 2 | 2 | 2 | 2 | All fans are required if OAT is above 41°C (106°F). | |
| GIA Cooling Fans (2 total) | 0 | 0 | 0 | 0 | 0 | Both fans are required if OAT is above 42°C (107°F). | |
| RNAV Operations, Equipment and Components | | | | | | Equipment and components required for RNAV 2, RNAV 1, B-RNAV, P-RNAV, Class II navigation, RNP and RNAV routes including Standard Instrument Departures (SIDs) and Obstacle Departure Procedures (ODPs), Standard Terminal Arrival (STAR), and enroute RNAV "Q" and RNAV "T" routes, and "GPS", "or GPS", and "RNAV (GPS)" instrument approach operations. | |
| GPS/SBAS receiver with GPS Software 3.2 or later approved version **Note 1, 2 | 1 | 1 | 2 | 2 | 2 | | |
| GDU 104X Display | 2 | 2 | 2 | 2 | 2 | | |
| GDU 1500 Display | 1 | 1 | 1 | 1 | 1 | | |
| GA36 antenna | 1 | 1 | 1 | 1 | 1 | NOTE 1: Some operations require two functioning GPS/SBAS receivers. | |
| GA37 antenna | 1 | 1 | 1 | 1 | 1 | NOTE 2: If only one is required, and only one is operative, it must be #1. | |
| OXYGEN No Changes - Refer to Aircraft Flight Manual | | | | | | | |
| PROPELLER No Changes - | | | | | | Refer to Aircraft's POH or AFMS for any installed modifications | |
| VACUUM SYSTEM | | | | | | | |
| Gyro Suction Gage | 0 | 0 | 0 | 0 | 1 | | |
| Instrument Air System | 0 | 0 | 0 | 0 | 1 | | |

This page intentionally left blank.

Section 3 - Emergency Procedures

Table of Contents

| | |
|--|-------------------------------------|
| AUTOMATIC FLIGHT CONTROL SYSTEM | 32 |
| AUTOPILOT MALFUNCTION / PITCH TRIM RUNAWAY..... | 32 |
| UNSCHEDULED RUDDER BOOST ACTIVATION | 33 |
| MANUAL AUTOPILOT DISCONNECT | 34 |
| AUTOPILOT ABNORMAL DISCONNECT | 34 |
| AUTOPILOT FAILURE | 35 |
| PITCH AXIS FAILURE..... | 36 |
| ROLL AXIS FAILURE..... | 36 |
| PITCH TRIM FAILURE | 37 |
| AUTOPILOT PRE-FLIGHT TEST FAIL..... | 37 |
| AUTOPILOT OVERSPEED RECOVERY | 38 |
| AUTOPILOT UNDERSPEED PROTECTION ACTIVATION AND RECOVERY (ESP-Equipped Aircraft Only)..... | Error! Bookmark not defined. |
| ENGINE FAILURE (AUTOPILOT ENGAGED) | 39 |
| ELECTRICAL SYSTEM..... | 39 |
| DUAL GENERATOR FAILURE [L DC GEN] [R DC GEN] | 39 |
| LOAD MANAGEMENT TABLE | 40 |
| TAWS AND GPWS | 41 |
| TAWS OR GPWS WARNING | 41 |
| TCAS II | 41 |
| TCAS II RESOLUTION ADVISORY | 41 |
| WINDSHEAR ENCOUNTER | 42 |
| ESP ENGAGEMENT | 42 |

Bolded checklist steps in the EMERGENCY PROCEDURES section indicate pilot memory action items. The pilot shall perform these items without reference to the checklist in this section.

AUTOMATIC FLIGHT CONTROL SYSTEM

AUTOPILOT MALFUNCTION / PITCH TRIM RUNAWAY

These procedures supersede the airplane's UNSCHEDULED ELECTRIC ELEVATOR TRIM ACTIVATION AFM checklist items.

If the airplane deviates unexpectedly from the planned flight path:

- 1. Control Wheel GRIP FIRMLY**
- 2. AP/YD DISC / TRIM INTRPT Button.....PRESS AND HOLD
(Be prepared for possible high elevator control forces)**
- 3. Aircraft Attitude MAINTAIN/REGAIN AIRCRAFT CONTROL
use standby attitude indicator if necessary**

NOTE

Do not release the AP/YD DISC / TRIM INTRPT Button until after pulling the AFCS SERVOS Circuit Breaker. The rudder boost will also be interrupted when the disconnect button is depressed.

- 4. Elevator Trim RE-TRIM if necessary using Elevator Tab Wheel**
- 5. AFCS SERVOS Circuit Breaker PULL
(Right circuit breaker panel)**

NOTE

Pulling the AFCS SERVOS circuit breaker will render the autopilot, yaw damper and rudder boost systems inoperative.

- 6. AP/YD DISC / TRIM INTRPT Button..... RELEASE**

WARNING

IN FLIGHT, DO NOT OVERPOWER THE AUTOPILOT. THE TRIM WILL OPERATE IN THE DIRECTION OPPOSING THE OVERPOWER FORCE, WHICH WILL RESULT IN LARGE OUT-OF-TRIM FORCES.

DO NOT ATTEMPT TO RE-ENGAGE THE AUTOPILOT OR USE MANUAL ELECTRIC PITCH TRIM UNTIL THE CAUSE OF THE MALFUNCTION HAS BEEN CORRECTED.

NOTE

The maximum altitude lost during malfunction tests was:

- Cruise – 230 Feet
- Descent – 555 Feet
- Maneuvering – 170 Feet
- Glideslope/Glidepath Approach – 79 Feet
- Non-Precision Approach – 100 Feet

UNSCHEDULED RUDDER BOOST ACTIVATION

These procedures supersede the airplane’s UNSCHEDULED RUDDER BOOST ACTIVATION AFM checklist items.

Rudder boost operation without a large variation of power between the engines indicates a failure of the system.

- 1. **AP/YD DISC / TRIM INTRPT ButtonPRESS AND HOLD**
- 2. **Rudder Boost OFF**

If Condition Persists:

- 3. **AFCS SERVOS Circuit Breaker PULL, or**
- 4. **Either Bleed Valve..... PNEU & ENVIR OFF**
- 5. Perform Normal Landing

NOTE

Pulling the AFCS SERVOS circuit breaker will render the autopilot, yaw damper and rudder boost systems inoperative.

MANUAL AUTOPILOT DISCONNECT

If necessary, the autopilot may be manually disconnected using any one of the following methods.

1. AP/YD DISC / TRIM INTRPT Button PRESS and RELEASE
(Pilot's or Copilot's control wheel)
2. AP Button (Autopilot mode control panel)..... PRESS
(Yaw damper remains engaged)
3. Pitch Trim Switch (Pilot's or, if installed, Copilot's control wheel)..... ACTIVATE
(Yaw damper remains engaged)
4. Go-Around (GA) switch (For airplanes without ESP Installed) PRESS
(Left power lever - yaw damper remains engaged)
5. AFCS SERVOS Circuit Breaker..... PULL
(Right circuit breaker panel)

AUTOPILOT ABNORMAL DISCONNECT

(Red 'AP' flashing on PFD, Continuous high-low aural tone)

1. A/P DISC/TRIM INTRPT ButtonPRESS AND RELEASE
(to cancel disconnect tone)
2. Aircraft Attitude..... MAINTAIN/REGAIN AIRCRAFT CONTROL

NOTE

The autopilot disconnect may be accompanied by a red boxed PTCH (pitch), ROLL, YAW or AFCS on the PFD, indicating the axis which has failed, or that the automatic flight control system has failed. The autopilot cannot be re-engaged with any of these annunciations present.

AUTOPILOT FAILURE

(Red **AFCS** annunciator on PFD, Red 'AP' flashing on PFD, Continuous high-low aural tone)

1. AP/YD DISC / TRIM INTRPT ButtonPRESS
(to cancel disconnect tone)

If red 'AFCS' is displayed, the autopilot, yaw damper, and manual electric pitch trim will be inoperative.

2. Advise ATC of loss of autopilot system.

NOTE

A loss of the autopilot may also cause yaw damper and rudder boost to be inoperative. Many King Air 300 aircraft require the yaw damper to be operative above 11,000 feet MSL, and rudder boost continuously. Refer to the Limitations section of the Aircraft Flight Manual, or appropriate Airplane Flight Manual Supplement for further information.

3. Altitude MONITOR AND MAINTAIN ASSIGNED ALTITUDE MANUALLY
Record each altimeter reading for contingency procedure use

NOTE

The standby altimeter must be corrected for position error using the Altimeter Correction – Standby System chart in the Performance section of this supplement.

4. Perform appropriate RVSM contingency procedures outlined in the operator's RVSM manual for the loss of automatic altitude hold capability.

PITCH AXIS FAILURE

(Red **PTCH** annunciator on PFD)

1. Indicates a failure of the pitch axis of the autopilot. The autopilot will be inoperative. The yaw damper will be operative.

NOTE

If the red **PTCH** annunciator illuminates without the autopilot engaged, it may indicate a faulted AHRS. Monitor both PFDs and the standby attitude indicator for abnormal attitude indications.

2. Advise ATC of loss of autopilot system.
3. Yaw DamperENGAGE AS REQUIRED
4. Altitude MONITOR AND MAINTAIN ASSIGNED ALTITUDE MANUALLY
Record each altimeter reading for contingency procedure use

NOTE

The standby altimeter must be corrected for position error using the Altimeter Correction – Standby System chart in the Performance section of this supplement.

5. Perform appropriate RVSM contingency procedures outlined in the operator’s RVSM manual for the loss of automatic altitude hold capability.

ROLL AXIS FAILURE

(Red **ROLL** annunciator on PFD)

1. Indicates a failure of the roll axis of the autopilot. The autopilot will be inoperative. The yaw damper will be operative.

NOTE

If the red **ROLL** annunciator illuminates without the autopilot engaged, it may indicate a faulted AHRS. Monitor both PFDs and the standby attitude indicator for abnormal attitude indications.

2. Advise ATC of loss of autopilot system.
3. Yaw DamperENGAGE AS REQUIRED
4. Altitude MONITOR AND MAINTAIN ASSIGNED ALTITUDE MANUALLY
Record each altimeter reading for contingency procedure use

NOTE

The standby altimeter must be corrected for position error using the Altimeter Correction – Standby System chart in the Performance section of this supplement.

5. Perform appropriate RVSM contingency procedures outlined in the operator’s RVSM manual for the loss of automatic altitude hold capability.

PITCH TRIM FAILURE

(Red **PTRM** annunciator on PFD)

1. Indicates a failure of the pitch trim servo of the autopilot. The autopilot will be inoperative. The yaw damper will remain operative.
2. Control Wheel GRIP FIRMLY
3. AP/YD DISC / TRIM INTRPT Button PRESS and RELEASE
(Be prepared for possible high elevator control forces)
4. Elevator Trim AS REQUIRED USING ELEVATOR TAB WHEEL

If Red **PTRM** Message Clears

5. Autopilot RE-ENGAGE

If Red **PTRM** Message Remains

5. Autopilot DO NOT RE-ENGAGE
6. Elevator Trim CONTINUE TO USE ELEVATOR TAB WHEEL
7. Yaw Damper ENGAGE AS REQUIRED

In RVSM Airspace:

8. Advise ATC of loss of autopilot system.
9. Altitude MONITOR AND MAINTAIN ASSIGNED ALTITUDE MANUALLY
Record each altimeter reading for contingency procedure use

NOTE

The standby altimeter must be corrected for position error using the Altimeter Correction – Standby System chart in the Performance section of this supplement.

10. Perform appropriate RVSM contingency procedures outlined in the operator's RVSM manual for the loss of automatic altitude hold capability.

AUTOPILOT PRE-FLIGHT TEST FAIL

(Red **PFT** annunciator on PFD)

1. Indicates the AFCS system failed the automatic Pre-Flight test. The autopilot, yaw damper and electric elevator trim are inoperative, and the rudder boost system may be inoperative. The Flight Director may still function.

AUTOPILOT OVERSPEED RECOVERY

(Amber **MAXSPD** annunciation on PFD)

1. Power Levers **REDUCE**

When overspeed condition is corrected:

2. Autopilot RESELECT VERTICAL MODE (if necessary)

NOTE

Overspeed recovery mode provides a pitch up command to decelerate the airplane at or below the maximum autopilot operating speed (259 KIAS / 0.58 M) or V_{FE} (200 or 157 KIAS) if the flaps are extended. Overspeed recovery is not active in altitude hold (ALT), glideslope (GS), or glidepath (GP) modes.

AUTOPILOT UNDERSPEED PROTECTION ACTIVATION AND RECOVERY (ESP-Equipped Aircraft Only)

(Red **UNDERSPEED PROTECT ACTIVE** Warning Annunciator on the PFDs on ESP-equipped aircraft. May also be accompanied by an amber **MINSPD** annunciator above the airspeed tape display and aural "AIRSPEED" alert)

1. Power Levers **INCREASE POWER AS REQUIRED TO CORRECT UNDERSPEED**
2. Aircraft Attitude and Altitude **MONITOR**

After underspeed condition is corrected:

3. Autopilot RESELECT VERTICAL AND LATERAL MODES (if necessary)
4. Power Levers ADJUST AS NECESSARY

NOTE

Autopilot Underspeed Protection Mode provides a pitch down command to maintain 100 +/- 2 KIAS, or 2 KIAS above stall warning airspeed, depending on the vertical mode selected. Underspeed recovery is not available below 200 feet AGL, except in go-around (GA) mode.

ENGINE FAILURE (AUTOPILOT ENGAGED)

1. AP/YD DISC / TRIM INTRPT Button **PRESS and RELEASE**
2. Engine Failure Procedure in
EMERGENCY PROCEDURES Section of AFM **COMPLETE**
3. Trim TabsMANUALLY ADJUST ELEVATOR, AILERON, AND RUDDER TABS
4. AutopilotPRESS 'AP' BUTTON (if desired) to RE-ENGAGE
5. Rudder TabMANUALLY ADJUST AS REQUIRED AFTER
POWER AND CONFIGURATION CHANGES

ELECTRICAL SYSTEM

DUAL GENERATOR FAILURE [L DC GEN] [R DC GEN]

This procedure should be performed prior to completing the respective section of the AFM checklist.

If Neither Generator Will Reset:

1. Standby Battery Switch INDICATES ARM or ON
2. The following equipment will be functional while the G1000 is powered from the aircraft's battery power, Avionics Master Power Switch is ON, and the [L GEN TIE OPEN], [R GEN TIE OPEN], [L DC GEN] and [R DC GEN] annunciators are illuminated.

Pilot's Attitude, Heading, Air Data, and Nav CDI

Copilot's Attitude, Heading, Air Data, and Nav CDI

MFD, Engine Gauges

Com 1, Pilot's Audio Panel, GPS 1, GPS 2, VHF Nav 1, VHF Nav 2, Transponder 1

Autopilot, Flight Director, Yaw Damper/Rudder Boost

NOTE

Inoperative G1000 equipment items will be displayed in the ALERTS window on both PFDs.

NOTE

The aircraft's battery will continue to power the G1000 equipment for at least 30 minutes following complete loss of normal electrical power generation. Once the aircraft's battery can no longer power the G1000, the standby battery will automatically power the standby attitude indicator, altimeter vibrator, the instrument emergency lights, and the internal lighting of the three standby instruments and magnetic compass for an additional 30 minutes.

NOTE

The Copilot and Standby Altimeter and Airspeed indicators may be unreliable in visible moisture because the Right Pitot Heat is not powered by the aircraft battery. The Left Pitot Heat remains powered by the battery via the aircraft's Triple Fed Bus.

LOAD MANAGEMENT TABLE

This table replaces the Load Management Table published in the AFM. Use of the following equipment will reduce battery duration by the approximate times listed below. Multiple usage of the following equipment is additive.

| EQUIPMENT | OPERATING TIME (Minutes) | REDUCTION IN MAIN BATTERY DURATION (Minutes) |
|---------------------------------------|--------------------------|--|
| Standby Altimeter | Continuous | None* |
| Standby Airspeed Indicator | Continuous | None* |
| Standby Attitude Indicator | Continuous | None* |
| Comm 1 Xmit | Continuous | ----- |
| Pilot Audio | Continuous | ----- |
| Nav 1 | Continuous | ----- |
| ADC 1 | Continuous | ----- |
| Pilot PFD | Continuous | ----- |
| AHRS 1 | Continuous | ----- |
| Transponder 1 | Continuous | ----- |
| GEA 1 | Continuous | ----- |
| MFD | Continuous | ----- |
| Copilot PFD | Continuous | ----- |
| Nav 2 | Continuous | ----- |
| ADC 2 | Continuous | ----- |
| AHRS 2 | Continuous | ----- |
| GEA 2 | Continuous | ----- |
| Instrument Indirect /Emergency Lights | Continuous | None* |
| Cabin Lights | 5 | 3 |
| Ice Lights | 5 | 0.6 |
| NAV Lights | 60 | 7 |
| Taxi Lights | 5 | 2 |
| Digital OAT | Continuous | ----- |
| Single Standby Fuel Pump | 5 | 2 |
| Left Bleed Air Valve | Continuous | ----- |
| Pressurization Control | Continuous | ----- |
| Cabin Temperature Control | Continuous | ----- |
| Surface Deice | 1 | 0.1 |
| Left and Right Main Engine Anti-ice | Single Operation | 0.1 |
| Manual Prop Deice | 5 | 6 |
| Windshield Wiper | 5 | 1 |
| Left Pitot Heat | Continuous | ----- |

*Powered by standby battery.

TAWS AND GPWS

TAWS OR GPWS WARNING

(Red **PULL UP** on PFD and aural “PULL UP” or “[Whoop, Whoop], PULL UP”

1. **AP/YD DISC / TRIM INTRPT Button** **PRESS and RELEASE
(To disconnect the autopilot)**
2. **Aircraft Attitude**.....**PULL BACK ON CONTROL WHEEL**
3. **Power**..... **MAXIMUM ALLOWABLE**
4. **Airspeed**.....**BEST ANGLE OF CLIMB SPEED**

After Warning Ceases:

5. **Power** **MAXIMUM CONTINUOUS**
6. **Altitude** **CLIMB AND MAINTAIN SAFE ALTITUDE**
7. **Advise ATC of Altitude Deviation, if appropriate.**

NOTE

Only vertical maneuvers are recommended, unless either operating in visual meteorological conditions (VMC), or the pilot determines, based on all available information, that turning in addition to the escape maneuver is the safest course of action, or both.

TCAS II

Refer to the GARMIN Pilot’s Guide, P/N 190-01343-00 Rev. A or later FAA approved revision for a detailed description of the TCAS II display and control elements as implemented in the G1000.

The following procedure should be performed in conjunction with the respective section of the TCAS-II AFMS checklist.

TCAS II RESOLUTION ADVISORY

(Red **TRAFFIC** and aural resolution advisory)

1. **Perform Resolution Advisory Procedures in the NORMAL PROCEDURES Section of the TCAS II AFMS.**
2. **Follow the green cues on the PFD VSI display as required to comply with the RA.**

Compliance with a TCAS II resolution advisory (RA) is necessary unless the pilot considers it unsafe to do so, or unless the pilot has information about the cause of the RA and can maintain safe separation for example visual acquisition of, and safe separation from, a nearby aircraft on a parallel approach.

WINDSHEAR ENCOUNTER

For airplanes equipped with Electronic Stability and Protection (ESP):

1. **AP/YD DISC / TRIM INTRPT Button** **PRESS and HOLD**
(To prevent automatic autopilot engagement)
2. **Perform established windshear escape procedures.**

After Exiting Windshear:

3. **AP/YD DISC / TRIM INTRPT Button** **RELEASE**
4. **Autopilot/Yaw Damper** **AS DESIRED**

NOTE

Refer to FAA Advisory Circular 00-54, Pilot Windshear Guide for additional information on windshear avoidance and escapement techniques.

ESP ENGAGEMENT

For airplanes equipped with Electronic Stability and Protection (ESP):

1. **Use the flight controls and power levers as required to correct the abnormal flight condition.**

NOTE

If the airplane remains within the ESP engagement envelope for more than approximately 10 seconds, the autopilot will automatically engage in LVL mode, and will be accompanied by an aural "ENGAGING AUTOPILOT" alert. Refer to Section 7 – Systems Description, "Electronic Stability & Protection" (ESP) for further information.

Section 3A - Abnormal Procedures

Table of Contents

| | |
|---|-----------|
| AUTOMATIC FLIGHT CONTROL SYSTEM | 45 |
| AILERON MIS-TRIM | 45 |
| ELECTRIC PITCH TRIM INOPERATIVE | 46 |
| ELEVATOR MIS-TRIM..... | 47 |
| RUDDER MIS-TRIM..... | 48 |
| FLASHING AMBER MODE ANNUNCIATION | 49 |
| YAW DAMPER AUTOMATIC DISCONNECT (Amber Flashing 'YD') | 49 |
| YAW AXIS FAILURE | 50 |
| ELECTRONIC STABILITY AND PROTECTION | 50 |
| MANUAL ESP DISENGAGEMENT..... | 50 |
| G1000 INTEGRATED AVIONICS SYSTEM | 51 |
| ALTITUDE MISCOMPARE..... | 51 |
| AIRSPEED MISCOMPARE | 54 |
| PITCH MISCOMPARE..... | 55 |
| ROLL MISCOMPARE..... | 55 |
| HEADING MISCOMPARE | 56 |
| LOSS OF ALTITUDE REPORTING IN RVSM AIRSPACE..... | 56 |
| LOSS OF ALTITUDE ERROR CORRECTION..... | 56 |
| DISPLAY UNIT FAILURE..... | 57 |
| PFD FAILURE..... | 57 |
| MFD FAILURE | 58 |
| DUAL GPS/SBAS FAILURE (AMBER "DR" OR "LOI" ON HSI)..... | 58 |
| GPS APPROACH ALARM LIMITS EXCEEDED | 59 |
| ILS DATABASE FREQUENCY AND/OR COURSE MISMATCH..... | 60 |
| LOSS OF RADIO TUNING FUNCTIONS | 60 |
| FAILED AIRSPEED, ALTITUDE, AND/OR VERTICAL SPEED..... | 61 |
| FAILED ATTITUDE AND/OR HEADING..... | 62 |
| ENGINE INDICATION SYSTEM (EIS) FAILURE..... | 64 |
| LOSS OF NAVIGATION DATA | 64 |
| INACCURATE FLIGHT DIRECTOR DISPLAY | 64 |
| BOTH ON ADC1, BOTH ON ADC2..... | 65 |

| | |
|--|-----------|
| BOTH ON AHRS 1, BOTH ON AHRS 2..... | 65 |
| BOTH ON GPS 1, BOTH ON GPS 2..... | 65 |
| USING ADC1 or ADC2..... | 66 |
| USING AHRS1 or AHRS2..... | 66 |
| SYNTHETIC VISION..... | 66 |
| TAWS AND GPWS..... | 67 |
| TAWS or GPWS CAUTION..... | 67 |
| TAWS INHIBIT..... | 67 |
| GPWS INHIBIT (TAWS-A Only) <input type="checkbox"/> GPWS INH..... | 68 |
| FLAP OVERRIDE (TAWS-A Only) <input type="checkbox"/> FLAP OVR..... | 68 |
| GLIDESLOPE/GLIDEPATH DEVIATION INHIBIT (TAWS-A Only)..... | 69 |
| TAWS N/A and TAWS FAIL..... | 69 |
| GPWS FAIL (TAWS-A only)..... | 69 |

AUTOMATIC FLIGHT CONTROL SYSTEM

AILERON MIS-TRIM (amber ←AIL or AIL→ annunciation on PFD)

Indicates a mis-trim of the ailerons while the autopilot is engaged. The autopilot cannot trim the airplane in roll. During large changes in airspeed, engine failure, or single engine operation, illumination of this message may occur. If the autopilot is disconnected while this message is displayed, high roll forces are possible. The following procedure should be followed:

1. Control Wheel GRIP FIRMLY
2. Aileron Tab Knob ROTATE SLOWLY IN DIRECTION OF INDICATED MIS-TRIM UNTIL THE ANNUNCIATION EXTINGUISHES

If the annunciator stays extinguished and no other annunciators illuminate:

3. Continue to operate the autopilot in a normal manner after the annunciation extinguishes.

If the annunciator remains illuminated or reappears with no changes in airspeed or configuration from the previous trimmed condition:

3. Control Wheel GRIP FIRMLY
4. Aileron Tab Knob ROTATE SLOWLY IN THE DIRECTION OF INDICATED MIS-TRIM UNTIL ANNUNCIATION EXTINGUISHES
5. AP/YD DISC / TRIM INTRPT Button PRESS and RELEASE
(Pilot's or Copilot's control wheel)
6. Aileron Trim USING AILERON TAB KNOB, MANUALLY RE-TRIM AIRPLANE

The autopilot should be considered inoperative until the cause of the mis-trim has been investigated and corrected. Yaw damper may be re-engaged and used normally.

In RVSM Airspace and Autopilot Inoperative:

7. Altitude MONITOR AND MAINTAIN ASSIGNED ALTITUDE MANUALLY
Record each altimeter reading for contingency procedure use

NOTE

The standby altimeter must be corrected for position error using the Altimeter Correction – Standby System chart in the Performance section of this supplement.

8. Advise ATC of loss of autopilot system. Perform appropriate RVSM contingency procedures outlined in the operator's RVSM manual for the loss of automatic altitude hold capability.

ELECTRIC PITCH TRIM INOPERATIVE

NOTE

This condition may be accompanied by a red **AFCS** or **PTRM** annunciation on the PFDs.

1. Move both halves of pilot and copilot pitch trim switches to check for stuck switch.
2. AFCS SERVOS Circuit Breaker..... PULL and RESET
(Right circuit breaker panel)

The autopilot will enter Pre-Flight Test (PFT) mode when the AFCS SERVOS circuit breaker is reset. If the autopilot successfully completes the Pre-Flight Test, re-engage the autopilot, reselect the desired autopilot modes, and continue to use normally. If the Pre-Flight Test fails, indicated by a red **PFT** on the PFDs, the autopilot, yaw damper, and electric pitch trim will be inoperative for the remainder of the flight.

If Operative:

3. Use as required.

If still inoperative:

3. Pitch Trim MANUALLY TRIM AIRPLANE IN PITCH
(Using Elevator Tab Wheel)

NOTE

The autopilot, yaw damper and rudder boost may also be inoperative. Many King Air 300 aircraft require the yaw damper to be operative above 11,000 feet MSL, and rudder boost continuously. Refer to the Limitations section of the Aircraft Flight Manual, or appropriate Airplane Flight Manual Supplement for further information.

In RVSM Airspace and Autopilot Inoperative:

4. Altitude MONITOR AND MAINTAIN ASSIGNED ALTITUDE MANUALLY
Record each altimeter reading for contingency procedure use

NOTE

The standby altimeter must be corrected for position error using the Altimeter Correction – Standby System chart in the Performance section of this supplement.

5. Advise ATC of loss of the autopilot system. Perform appropriate RVSM contingency procedures outlined in the operator's RVSM manual for the loss of automatic altitude hold capability.

ELEVATOR MIS-TRIM (amber **↓ELE** or **↑ELE** annunciation on PFD)

Indicates a mis-trim of the elevator tab while the autopilot is engaged. The autopilot will normally trim the airplane as required. However, during rapid acceleration, deceleration, or configuration changes, momentary illumination of this message may occur accompanied by minor fluctuations in flight path. If the autopilot is disconnected while this message is displayed, high elevator control forces are possible. In the event of sustained illumination, the following procedure should be followed:

1. Control Wheel GRIP FIRMLY
2. Elevator Tab Wheel..... ROTATE SLOWLY IN THE DIRECTION OF INDICATED MIS-TRIM UNTIL ANNUNCIATION EXTINGUISHES

If the annunciator stays extinguished and no other annunciators illuminate:

3. Continue to operate the autopilot in a normal manner after the annunciation extinguishes.

If the annunciator remains illuminated or reappears with no changes in airspeed or configuration from the previous trimmed condition:

3. Control Wheel GRIP FIRMLY
4. Elevator Tab Wheel..... ROTATE SLOWLY IN THE DIRECTION OF INDICATED MIS-TRIM UNTIL ANNUNCIATION EXTINGUISHES
5. AP/YD DISC / TRIM INTRPT Button PRESS and RELEASE
(Pilot's or Copilot's control wheel)
6. Pitch Trim USING ELEVATOR TAB WHEEL, MANUALLY RE-TRIM AIRPLANE

Autopilot should be considered inoperative until the cause of the mis-trim has been investigated and corrected. Yaw damper may be re-engaged and used normally.

In RVSM Airspace and Autopilot Inoperative:

7. Altitude MONITOR AND MAINTAIN ASSIGNED ALTITUDE MANUALLY
Record each altimeter reading for contingency procedure use

NOTE

The standby altimeter must be corrected for position error using the Altimeter Correction – Standby System chart in the Performance section of this supplement.

8. Advise ATC of loss of the autopilot system. Perform appropriate RVSM contingency procedures outlined in the operator's RVSM manual for the loss of automatic altitude hold capability.

RUDDER MIS-TRIM (amber  or  annunciation on PFD)

Indicates a mis-trim of the rudder while the autopilot is engaged. The autopilot cannot trim the airplane in yaw. During large changes in airspeed, engine failure, or single engine operation, illumination of this message may occur. If the autopilot is disconnected while this message is displayed, high rudder pedal forces and yawing motion are possible. The following procedure should be followed:

1. Rudder PedalsHOLD FIRMLY
2. Rudder Tab Knob.....ROTATE SLOWLY IN THE DIRECTION OF INDICATED MIS-TRIM UNTIL ANNUNCIATION EXTINGUISHES

If the annunciator stays extinguished and no other annunciations illuminate:

3. Continue to operate the autopilot in a normal manner after the annunciation extinguishes.

If the annunciator remains illuminated or reappears with no changes in airspeed or configuration from the previous trimmed condition:

3. Rudder PedalsHOLD FIRMLY
4. Rudder Tab Knob.....ROTATE SLOWLY IN THE DIRECTION OF INDICATED MIS-TRIM UNTIL ANNUNCIATION EXTINGUISHES
5. Autopilot DISCONNECT
6. Rudder Tab Knob.....MANUALLY RE-TRIM AIRPLANE

NOTE

Yaw Damper should be considered inoperative until the cause of the mis-trim has been investigated and corrected. The rudder boost may also be inoperative. Many King Air 300 aircraft require the yaw damper to be operative above 11,000 feet MSL, and rudder boost continuously. Refer to the Limitations section of the Aircraft Flight Manual, or appropriate Airplane Flight Manual Supplement for further information.

7. AutopilotENGAGE

In RVSM Airspace and Autopilot Inoperative:

8. AltitudeMONITOR AND MAINTAIN ASSIGNED ALTITUDE MANUALLY
Record each altimeter reading for contingency procedure use

NOTE

The standby altimeter must be corrected for position error using the Altimeter Correction – Standby System chart in the Performance section of this supplement.

9. Advise ATC of loss of the autopilot system. Perform appropriate RVSM contingency procedures outlined in the operator’s RVSM manual for the loss of automatic altitude hold capability.

FLASHING AMBER MODE ANNUNCIATION

NOTE

Abnormal mode transitions (those not initiated by the pilot or by normal sequencing of the AFCS) will be annunciated by flashing the disengaged mode in amber on the PFD. Upon loss of a selected mode, the system will revert to the default mode for the affected axis, either ROL or PIT. After 10 seconds, the new mode (PIT or ROL) will be annunciated in green.

LOSS OF SELECTED VERTICAL MODE (FLC, VS, VPTH, ALT, GS, GP)

1. Autopilot mode controls.....SELECT ANOTHER VERTICAL MODE

If on an instrument approach, disconnect autopilot and continue manually or execute missed approach:

2. AP/YD DISC / TRIM INTRPT Button PRESS and RELEASE

LOSS OF SELECTED LATERAL MODE (HDG, VOR, GPS, LOC, VAPP, BC)

1. Autopilot mode controls.....SELECT ANOTHER LATERAL MODE

If on an instrument approach, disconnect autopilot and continue manually or execute missed approach:

2. AP/YD DISC / TRIM INTRPT Button PRESS and RELEASE

YAW DAMPER AUTOMATIC DISCONNECT (Amber Flashing 'YD')

Flashing amber 'YD' in flight indicates that yaw damper has disconnected. If the disconnect was not pilot initiated, the yaw servo has failed. The autopilot may be re-engaged after a yaw servo failure.

NOTE

Many King Air 300 aircraft require the yaw damper to be operative above 11,000 feet MSL, and rudder boost continuously. Refer to the Limitations section of the Aircraft Flight Manual, or appropriate Airplane Flight Manual Supplement for further information.

YAW AXIS FAILURE (Amber **YAW** annunciator on PFD)

1. Indicates a failure of the yaw axis of the autopilot. The yaw damper will disconnect. The autopilot may be engaged and disengaged normally, but the yaw damper and rudder boost will be inoperative.
2. Autopilot AS DESIRED

WARNING

DO NOT USE THE AUTOPILOT ON A COUPLED ILS APPROACH WITH A FAILED YAW SERVO. THE AUTOPILOT MAY NOT BE ABLE TO MAINTAIN DIRECTIONAL CONTROL IN THE EVENT OF AN ENGINE FAILURE.

NOTE

If the amber **YAW** annunciator illuminates without the autopilot engaged, it may indicate a faulted AHRS. Monitor both PFDs and the standby attitude indicator for abnormal attitude indications.

NOTE

Many King Air 300 aircraft require the yaw damper to be operative above 11,000 feet MSL, and rudder boost continuously. Refer to the Limitations section of the Aircraft Flight Manual, or appropriate Airplane Flight Manual Supplement for further information.

ELECTRONIC STABILITY AND PROTECTION

MANUAL ESP DISENGAGEMENT

If necessary, ESP may be manually disconnected using any one of the following methods.

1. AP/YD DISC / TRIM INTRPT ButtonPRESS and HOLD
(Pilot's or Copilot's control wheel)
2. CWS Button (Pilot's or Copilot's control wheel)PRESS and HOLD
3. AFCS SERVOS Circuit Breaker PULL
(Right circuit breaker panel)
4. AUX – SYSTEM SETUP 2 Page on MFD DISABLE STABILITY AND PROTECTION

G1000 INTEGRATED AVIONICS SYSTEM

ALTITUDE MISCOMPARE



This message is displayed when the G1000 detects a difference of 200 feet or greater between the pilot's and copilot's altitude information. Refer to the G1000 Cockpit Reference Guide for additional information.

1. Altimeter Settings VERIFY both pilot and copilot have the correct barometric altimeter setting.
2. Pilot's and Copilot's Altitude..... COMPARE with Standby Altimeter



THE STANDBY ALTIMETER USES THE SAME STATIC SOURCE AS THE COPILOT'S SIDE AIR DATA COMPUTER (ADC2). DO NOT USE STANDBY ALTIMETER AS SOLE SOURCE IN DETERMINING CORRECT ALTITUDE.

If Pilot and Standby Altimeter Agree (Copilot Altimeter Differs):

NOTE

The standby altimeter must be corrected for position error using the Altimeter Correction – Standby System chart in the Performance section of this supplement.

3. SENSOR Softkey (Copilot PFD) PRESS
 4. ADC1 Softkey PRESS
 5. PFD Displays CONFIRM annunciator is displayed on both PFDs.
- In RVSM Airspace:
6. Altitude CROSS-CHECK USING STANDBY ALTIMETER
Record each altimeter reading for contingency procedure use
 7. Advise ATC of loss of redundancy of primary altimetry systems. Perform appropriate RVSM contingency procedures outlined in the operator's RVSM manual for the loss of primary altimetry systems.

If Copilot and Standby Altimeter Agree (Pilot Altimeter Differs):

NOTE

The standby altimeter must be corrected for position error using the Altimeter Correction – Standby System chart in the Performance section of this supplement.

- 3. Autopilot ALT Mode..... DISENGAGED
- 4. Pilot’s Static Air Source..... SELECT ALTERNATE

A sudden sustained change in rate-of-climb indication accompanied by abnormal indicated airspeed and altitude changes beyond normal calibrated differences observed on the Pilot’s PFD would indicate a blockage of the pilot’s static system.

- If Pilot’s and Copilot’s altimeters agree within normal calibrated differences with Pilot’s Alternate Static Air Source in the ALTERNATE position:

Refer to Section 5, PERFORMANCE in the aircraft AFM for Airspeed Calibration-Alternate System and Altimeter Correction–Alternate System for the Pilot’s Altimeter.

- In RVSM Airspace:

- 5. Altitude CROSS-CHECK USING STANDBY ALTIMETER
Record each altimeter reading for contingency procedure use
- 6. Advise ATC of loss of redundancy of primary altimetry systems. Perform appropriate RVSM contingency procedures outlined in the operator’s RVSM manual for the loss of redundancy of primary altimetry systems.

If no change in rate-of-climb, airspeed, or altitude is observed:

- 7. Pilot’s Static Air Source..... SELECT NORMAL
- 8. Compare indicated altitude to GPS altitude on MFD AUX-GPS STATUS page to aid in determining which primary system is most accurate.

NOTE

When comparing indicated altitude to GPS altitude, deviations from standard temperature or pressure can cause indicated altitude to deviate from GPS altitude. Those errors are largest at high altitude. Below 10,000 feet with the correct local altimeter setting set, GPS altitude will usually be within 600 feet or better of the correct indicated altitude. Use the following guidelines to help estimate correct altitude from non-standard conditions:

- Temperatures WARMER than standard can cause GPS altitude to read HIGHER than indicated altitude.
- Pressures LOWER than standard can cause GPS altitude to read HIGHER than indicated altitude.

If Able to Identify Accurate Altitude Source:

1. Autopilot ALT Mode..... DISENGAGED
2. Use SENSOR softkey to select most accurate ADC on both PFD's.
3. Confirm **BOTH ON ADC1** or **BOTH ON ADC2** annunciators are displayed on both PFDs
4. Autopilot ALT Mode..... ENGAGE AS DESIRED
- In RVSM Airspace:
5. Altitude CROSS-CHECK USING STANDBY ALTIMETER
Record each altimeter reading for contingency procedure use

NOTE

The standby altimeter must be corrected for position error using the Altimeter Correction – Standby System chart in the Performance section of this supplement.

6. Advise ATC of loss of redundancy of primary altimetry systems. Perform appropriate RVSM contingency procedures outlined in the operator's RVSM manual for the loss of redundancy of primary altimetry systems.

If Unable to Identify Accurate Altitude Source:

1. Avoid IFR conditions if possible; consider diversion to visual conditions and LAND AS SOON AS PRACTICAL.
2. Maintain altitudes based on LOWEST indicated altitude.
3. Advise ATC of inability to verify correct altitude. If in RVSM airspace, perform appropriate RVSM contingency procedures for loss of all primary altimetry systems and accurate altitude reporting capability.
4. If unable to descend in visual conditions, plan an ILS, LPV, or RNAV (GPS) LNAV/VNAV approach with course intercept well outside the Final Approach Fix (FAF).
5. Once glideslope or glidepath is captured, determine most accurate altitude source when crossing FAF.
6. Reference ILS Decision Altitude or GPS based approach Minimum Descent Altitude to most accurate altimeter based on FAF crossing.

WARNING

VARIOUS TAWS ALERTS ARE BASED ON GPS ALTITUDE AND POSITION INFORMATION. TAWS WARNINGS AND CAUTIONS ARE INDEPENDENT OF ADC DATA. IF A TAWS WARNING OR CAUTION IS RECEIVED, CONSIDER IT ACCURATE AND TAKE IMMEDIATE AVOIDANCE ACTION.

AIRSPEED MISCOMPARE

IAS MISCOMP

This message is displayed when the G1000 detects a difference of 7 KIAS or greater between the pilot's and copilot's airspeed indicators (10 KIAS difference during takeoff or landing roll). Refer to the G1000 Cockpit Reference Guide for additional information.

1. Pilot's and Copilot's Airspeed COMPARE with Standby Airspeed Indicator

WARNING

THE STANDBY AIRSPEED INDICATOR USES THE SAME PITOT-STATIC SOURCES AS THE COPILOT'S SIDE AIR DATA COMPUTER (ADC2). DO NOT USE STANDBY AIRSPEED INDICATOR OR STANDBY ALTIMETER AS SOLE SOURCE IN DETERMINING CORRECT AIR DATA INFORMATION.

If Pilot and Standby Airspeed Indicator Agree (Copilot Airspeed Differs):

NOTE

The standby altimeter must be corrected for position error using the Altimeter Correction – Standby System chart in the Performance section of this supplement.

2. SENSOR Softkey (Copilot's PFD) PRESS
3. ADC1 Softkey PRESS
4. PFD Displays CONFIRM **BOTH ON ADC1** annunciator is displayed on both PFDs
- In RVSM airspace:
5. Altitude CROSS-CHECK USING STANDBY ALTIMETER
Record each altimeter reading for contingency procedure use

NOTE

The standby altimeter must be corrected for position error using the Altimeter Correction – Standby System chart in the Performance section of this supplement.

6. Advise ATC of loss of redundancy of primary altimetry systems. Perform appropriate RVSM contingency procedures outlined in the operator's RVSM manual for the loss of redundancy of primary altimetry systems.

If Copilot and Standby Airspeed Indicator Agree (Pilot Airspeed Differs):

NOTE

The standby altimeter must be corrected for position error using the Altimeter Correction – Standby System chart in the Performance section of this supplement.

2. Pilot and Copilot ALTITUDE NOTE

If Pilot's and Copilot's Altitude Agree:

3. Airspeed 120 KIAS MINIMUM on slowest indicator.
4. Monitor all three airspeed indicators during changes in power or altitude to determine which indicators are inaccurate. Indications of inaccurate airspeed include:
 - No change in indicated airspeed when power change and altitude maintained.
 - Indicated airspeed increases when climbing or decreases when descending.
5. Use SENSOR softkey to select most accurate ADC on the affected PFDs.
6. AirspeedRESUME NORMAL SPEEDS

If Pilot's and Copilot's Altitude Do Not Agree:

3. Refer to Abnormal Procedures, ALT MISCOMP procedure to determine most accurate ADC.

PITCH MISCOMPARE **PIT MISCOMP**

This message is displayed in the upper right corner of the PFD when the G1000 detects a difference between the pilot's and copilot's pitch attitude of more than 5 degrees. Refer to GARMIN G1000 Cockpit Reference Guide for additional information.

1. Refer to STANDBY ATTITUDE indicator to determine which AHRS is providing the most accurate data.
2. Use SENSOR softkey to select the most accurate AHRS on the affected PFD.

ROLL MISCOMPARE **ROLL MISCOMP**

This message is displayed in the upper right corner of the PFD when the G1000 detects a difference between the pilot's and copilot's roll attitude of more than 6 degrees. Refer to the GARMIN G1000 Cockpit Reference Guide for additional information.

1. Refer to STANDBY ATTITUDE indicator to determine which AHRS is providing the most accurate data.
2. Use SENSOR softkey to select the most accurate AHRS on the affected PFD.

HEADING MISCOMPARE **HDG MISCOMP**

This message is displayed in the upper right corner of the PFD when the G1000 detects a difference between the pilot's and copilot's heading information. Refer to the GARMIN G1000 Cockpit Reference Guide for additional information.

1. WSHLD ANTI-ICE Switches (PILOT and COPILOT) OFF
2. CABIN TEMP MODE selector..... OFF
3. ELEC HEAT OFF
4. Refer to Magnetic Compass to determine which AHRS is providing the most accurate heading information.
5. Use SENSOR softkey to select the most accurate AHRS on the affected PFD.
6. WSHLD ANTI-ICE Switches AS REQUIRED
7. CABIN TEMP MODE AS DESIRED
8. ELEC HEAT AS REQUIRED

NOTE

The magnetic compass is affected by windshield anti-ice and/or air conditioner operation. These items must be turned OFF prior to referencing magnetic compass heading, and then may be reselected ON. With windshield anti-ice OFF, fog or frost may form on the inside surface of the windshield. The windshield anti-ice should be turned off only long enough to reference magnetic compass or the pilot should descend to a warmer altitude if terrain, fuel, and endurance permit.

LOSS OF ALTITUDE REPORTING IN RVSM AIRSPACE

If ATC is not receiving altitude reporting information while in RVSM airspace:

1. XPDR SoftkeySELECT OTHER TRANSPONDER
2. Verify selected transponder is in ALT mode.

LOSS OF ALTITUDE ERROR CORRECTION

Loss of altitude (static source) error correction in the air data computers is indicated by an advisory message in the alerts window of the PFD. The static source error correction is effective only above 18,000 feet MSL. The following advisory messages will post:

ADC1 ALT EC - ADC1 altitude error correction is unavailable.

and/or

ADC2 ALT EC - ADC2 altitude error correction is unavailable.

If a loss of altitude error correction advisory is received:

- Above 18,000 feet MSL:
 1. AltitudeMAINTAIN USING CROSS-SIDE ALTIMETER OR STANDBY ALTIMETER

NOTE

The standby altimeter must be corrected for position error using the Altimeter Correction – Standby System chart in the Performance section of this supplement.

- In RVSM Airspace:
 1. Advise ATC of loss of redundancy of primary altimetry systems. Perform appropriate RVSM contingency procedures outlined in the operator’s RVSM manual for the loss of redundancy of primary altimetry systems.
 2. Record each altimeter reading for RVSM contingency procedure use.

DISPLAY UNIT FAILURE

PFD FAILURE

PFD failure is indicated by a complete loss of image on a display. The pilot should use the cross side PFD and the standby flight instruments for information to fly the airplane. If only individual elements of the display are failed, refer to appropriate procedures for the individual failures.

To display composite primary flight information and the engine instruments on the MFD:

1. DISPLAY BACKUP Button (on audio panel of affected side).....PRESS

The DISPLAY BACKUP button may be pressed again to return the MFD to its normal presentation. With the MFD in its normal display presentation, the pilot has access to functions and pages unique to the MFD that are not accessible when the MFD is in the composite display.

NOTE

The CDI SYNC and BARO SYNC settings must be ON to allow the operating PFD controls to affect settings on the MFD when the MFD is in the Display Backup mode. These settings are accessible on the MFD when in the normal display presentation on the AUX – SYSTEM SETUP page.

2. Autopilot Mode Panel.....TRANSFER (XFR button) to operating PFD
3. Autopilot RE-ENGAGE and select modes
4. Transponder.....SELECT operating transponder
5. Audio Panels..... SELECT operating COM Radio

NOTE

Use the operating PFD to control Com frequency selection, Com and Nav volume, and Altimeter Barometric Pressure setting.

MFD FAILURE

MFD failure is indicated by a complete loss of image on the center display. A failed MFD will auto-revert to PFD 1 to display engine data on PFD 1. Engine data may be displayed on PFD 2 by pressing the Copilot's Audio Panel DISPLAY BACKUP button.

If MFD auto-reversion does not occur, or to manually revert the PFD 2 display:

1. Audio Panel DISPLAY BACKUP Button PRESS
2. Electronic Chart Data will not be available following an MFD failure. Use the following procedure if a secondary source of aeronautical information is not available in the airplane.
 - a. Load approaches, arrivals, and departures into the Active Flight Plan using the PROC button on either PFD. The procedure's course can be displayed on either PFD Inset Map window. Navigate using the course pointer and CDI on the PFDs.
 - b. For instrument approach procedures, obtain altitude information from ATC.

DUAL GPS/SBAS FAILURE (AMBER "DR" OR "LOI" ON HSI)

LOSS OF GPS/SBAS NAVIGATION DATA

When both GPS/SBAS receivers are inoperative or GPS navigation information is not available or invalid, the G1000 system will enter one of two modes: Dead Reckoning mode (DR) or Loss Of Integrity mode (LOI). The mode is indicated on the HSI by an amber "DR" or "LOI". Which mode is active depends on the distance from the destination airport in the active flight plan.

If the LOI annunciation is displayed, revert to an alternate means of navigation appropriate to the route and phase of flight. In Dead Reckoning mode, the MAP – NAVIGATION MAP will continue to be displayed with a ghosted aircraft icon in the center and an amber 'DR' overwriting the icon. Aircraft position will be based upon the last valid GPS position, then estimated by Dead Reckoning methods. Changes in true airspeed, altitude, or winds aloft can affect the estimated position substantially. Dead Reckoning is only available in Enroute mode; Terminal and Approach modes do not support DR. Course deviation information will be displayed as an amber CDI on both PFDs and will remain for up to 20 minutes after GPS position data has been lost. The autopilot and/or flight director may be coupled in GPS mode while the system is in Dead Reckoning mode. Refer to the G1000 Cockpit Reference Guide for further information. Revert to an alternate means of navigation appropriate to the route and phase of flight.

If Alternate Navigation Sources (ILS, LOC, VOR, DME, ADF) Are Available:

1. Navigation USE ALTERNATE SOURCES

If No Alternate Navigation Sources Are Available:

DEAD RECKONING (DR) MODE - ACTIVE WHEN THE AIRPLANE IS GREATER THAN 30 NM FROM THE DESTINATION AIRPORT:

1. Navigation - Use the airplane symbol, magenta course line on the map display and the amber CDI for course information.

NOTE

- ALL INFORMATION NORMALLY DERIVED FROM GPS TURNS AMBER. ALL OF THIS INFORMATION WILL BECOME LESS ACCURATE OVER TIME.
- TAWS is inoperative.
- DR mode uses heading, true airspeed, last known wind data, and the last known GPS position to estimate the airplane's current position. DR information will be available for a maximum of 20 minutes.
- MAP – TRAFFIC MAP display is not dependent on GPS information. The position of displayed traffic relative to the airplane symbol on the map is still accurate.

LOSS OF INTEGRITY (LOI) MODE - ACTIVE WHEN THE AIRPLANE IS WITHIN 30NM OF THE DESTINATION OR DEPARTURE AIRPORT (AS CALCULATED FROM THE PREVIOUS GPS OR DR POSITION):

1. Navigation - Fly toward known visual conditions. Use ATC or other information sources as available.

NOTE

- All information derived from GPS or DR will be removed from the displays.
- TAWS is inoperative.
- The airplane symbol is removed from all maps. The map will remain centered at the last known position. "NO GPS POSITION" will be annunciated in the center of the map.

GPS APPROACH ALARM LIMITS EXCEEDED

During a GPS LPV, LNAV/VNAV, or LNAV+V approach, if the Horizontal or Vertical alarm limits are exceeded, the G1000 System will downgrade the approach. This will be annunciated in the ALERTS window and by an annunciation change on the HSI from LPV, L/VNAV, or LNAV+V to LNAV. GPS glide path vertical guidance will be removed from the PFD. The approach may be continued using the LNAV only minimums.

During any GPS approach in which both precision and non-precision alarm limits are exceeded, the G1000 System will flag the lateral guidance and display a system message "ABORT APPROACH loss of navigation". Immediately upon viewing the message, the unit will revert to Terminal navigation mode alarm limits. If the position integrity is within these limits lateral guidance will be restored and the GPS may be used to execute the missed approach, otherwise alternate means of navigation must be utilized.

ILS DATABASE FREQUENCY AND/OR COURSE MISMATCH

In some rare instances, the actual course and/or frequency for an ILS localizer may not match the course or frequency stored in the G1000 database. This occurs most often when an ILS course or frequency change is made by the FAA in between Jeppesen database update cycles. Manual course or frequency changes can be made to override the auto-loaded values in the G1000 database whenever an ILS approach is loaded into the G1000 via the FMS. ADVISORY messages will post in the ALERTS window on the PFDs prompting the pilot verify course and/or frequency information. Use the latest published instrument approach procedure information to verify all course and frequency information.

While flying ILS approaches with manually overridden course or frequency information:

- For airplanes with TAWS-A installed, the Glideslope Deviation Alerting (GSD) will be function normally.
- If SVS Pathways are turned on for display, they must be turned off prior to turning inbound onto the final approach course to prevent possible confusion. This is because the pathway display is also dependent on accurate database information to display proper guidance.

If SVS Pathways are Displayed While Flying a Manually Overriden Frequency or Course on an ILS Approach:

Prior to Turning Inbound on the Final Approach Course:

1. PFD Softkey on PFD1 and/or PFD2 PRESS
2. SYN VIS SoftkeyPRESS
3. PATHWAY SoftkeyPRESS TO REMOVE PATHWAY DISPLAY

LOSS OF RADIO TUNING FUNCTIONS

1. COM Frequency Toggle ButtonPRESS AND HOLD FOR 2 SECONDS

NOTE

The above procedure will tune the active COM field to the emergency frequency 121.5. Certain failures of the tuning system will automatically tune 121.5 without pilot action.

If the EMERG FREQ switch is installed, the following alternate procedure may be used:

1. EMERG FREQ switchLIFT COVER AND PRESS

NOTE

The above procedure will tune the active COM 1 field to the emergency frequency 121.5. COM 2 operation is not controlled by the EMERG FREQ switch.

FAILED AIRSPEED, ALTITUDE, AND/OR VERTICAL SPEED

(RED "X" ON PFD AIRSPEED, ALTITUDE, AND/OR VERTICAL SPEED INDICATORS)

This indicates a loss of valid air data computer information to the respective system.

If Both Sides:

1. Airspeed, Altitude and Attitude..... MONITOR using standby indicators

NOTE

The standby altimeter must be corrected for position error using the Altimeter Correction – Standby System chart in the Performance Section of this Supplement.

2. Autopilot ALT Mode..... DIS-ENGAGED
3. Advise ATC of loss of all primary altimetry systems and if in RVSM airspace perform the appropriate RVSM contingency procedures for loss of all primary altimetry systems and accurate altitude reporting capability outlined in the operator's RVSM procedures manual.
4. Land as soon as practical.

If One Side Only:

1. Autopilot ALT Mode..... DISENGAGED
 2. Affected PFD SENSOR Softkey PRESS
 3. ADC Softkey..... PRESS the ADC softkey to select the functional ADC (ADC1 or ADC2)
 4. Both PFDs..... CONFIRM "BOTH ON ADC1" OR "BOTH ON ADC2" annunciated on both PFDs.
 5. Autopilot ALT Mode..... RESELECT AS DESIRED
- In RVSM Airspace:
6. Altitude CROSS-CHECK USING STANDBY ALTIMETER
Record each altimeter reading for contingency procedure use

NOTE

The standby altimeter must be corrected for position error using the Altimeter Correction – Standby System chart in the Performance section of this supplement.

7. Perform appropriate RVSM contingency procedures for loss of redundancy of primary altimetry systems, outlined in the operator's RVSM procedures manual.

LOSS OF ALTITUDE ALERTER IN RVSM AIRSPACE

1. Autopilot ALT Mode..... ENGAGED.
2. Altitude MONITOR AND MAINTAIN ASSIGNED ALTITUDE
3. Perform appropriate RVSM contingency procedures for the loss of altitude alerting, outlined in the operator's RVSM procedures manual.

FAILED ATTITUDE AND/OR HEADING

(ATTITUDE FAIL AND/OR RED "X" OVER HEADING DISPLAY ON PFD)

This indicates a loss of pitch, roll, and/or heading information from AHRS. Refer to GARMIN G1000 Cockpit Reference Guide and Pilot's Guide for additional information. Interference from GPS repeaters operating inside nearby hangars or magnetic anomalies caused by nearby structures can cause an intermittent loss of attitude and heading displays while the aircraft is on the ground. This is usually accompanied by a BOTH ON GPS 1, BOTH ON GPS 2, or LOI annunciation. Moving the aircraft more than 100 yards away from the source of the interference should alleviate the condition.

Taxiing the aircraft before a valid GPS position has been acquired can cause attitude and/or heading display to indicate a failed condition. As soon as the aircraft acquires a valid GPS position, attitude and heading should return to normal.

WARNING

DO NOT TAKE OFF WITHOUT VALID, NORMAL ATTITUDE AND HEADING DISPLAYS

In Flight, If Both Sides:

1. AttitudeMONITOR using standby attitude gyro
2. WSHLD ANTI-ICE Switches (Pilot and Copilot)..... OFF

NOTE

The magnetic compass is erratic during windshield anti-ice and/or air conditioner operation. With windshield anti-ice OFF, windshield may form fog or frost on the inside surface. The windshield anti-ice should be turned off only long enough to reference magnetic compass or the pilot should descent to a warmer altitude if terrain, fuel, and endurance permit.

3. ELEC HEAT OFF
4. CABIN TEMP MODE switch OFF
5. Heading MONITOR using magnetic compass

If in RVSM airspace:

6. Altitude MONITOR AND MAINTAIN ASSIGNED ALTITUDE MANUALLY
Record each altimeter reading for contingency procedure use

NOTE

The standby altimeter must be corrected for position error using the Altimeter Correction – Standby System chart in the Performance section of this supplement.

7. Advise ATC of loss of autopilot system. Perform appropriate RVSM contingency procedures for loss of altitude hold capability, outlined in the operator's RVSM procedures manual.
8. Land as soon as practical.

NOTE

- The autopilot will disconnect and will not re-engage. ESP (if installed) will be inoperative.
- Reference the GPS track on MFD/PFD map to improve situational awareness. GPS will continue to display correct GPS based map, position, and track.
- Magnetic compass is influenced by windshield anti-ice and/or air conditioner operation. These items must be turned OFF prior to referencing magnetic compass heading. Leave these items OFF when maneuvering the aircraft by reference to the magnetic compass.

In Flight, If One Side Only:

1. Standby Attitude Gyro MONITOR
2. Affected PFD SENSOR softkey PRESS
3. AHRS softkeyPRESS Opposite Side AHRS softkey
4. Both PFDs CONFIRM VALID ATTITUDE AND HEADING ARE DISPLAYED
CONFIRM "BOTH ON AHRS1" or
"BOTH ON AHRS2" annunciated on both PFDs

NOTE

The autopilot will disconnect and will not re-engage. ESP (if installed) will be inoperative.

If in RVSM airspace and autopilot inoperative:

5. Altitude MONITOR AND MAINTAIN ASSIGNED ALTITUDE MANUALLY
Record each altimeter reading for contingency procedure use

NOTE

The standby altimeter must be corrected for position error using the Altimeter Correction – Standby System chart in the Performance section of this supplement.

6. Advise ATC of loss of autopilot system. Perform appropriate RVSM contingency procedures for loss of altitude hold capability, outlined in the operator's RVSM procedures manual.

ENGINE INDICATION SYSTEM (EIS) FAILURE

(RED 'X' ON ENGINE DISPLAY)

If All Engine Gauges on One Engine Red 'X':

Indicates failure of the GEA for that engine

1. Check GEA circuit breakers RESET once if tripped

If unable to restore engine gauges:

2. Move both power levers together using the engine with operating engine gauges to set power.

If One or More Engine Parameter Indications Are Flagged On Only One Engine:

1. Adjust power using the remaining indications and comparing to the opposite engine.

LOSS OF NAVIGATION DATA

(LATERAL DEVIATION BAR NOT PRESENT AND/OR GLIDESLOPE INDEX
CLEARS)

This indicates a loss of data from the selected NAV source. Refer to GARMIN G1000 Cockpit Reference Guide for additional information.

1. CDI SoftkeyPRESS TO SELECT ALTERNATE NAVIGATION SOURCE
2. CONFIRM a valid navigation source is displayed giving valid navigation guidance.

INACCURATE FLIGHT DIRECTOR DISPLAY

Indicated by one or both flight directors commanding attitude contrary to intended flight path:

1. AP/YD DISC / TRIM INTRPT ButtonPRESS
(Pilot's or Copilot's control wheel)
2. Attitude CROSSCHECK BOTH PFDs with the Standby Attitude Indicator
3. Flight Director Modes RESELECT AS DESIRED

NOTE

If continued use of the flight director is desired, it is recommended that only basic modes (i.e., ROL and PIT) be selected initially. If this proves satisfactory, HDG and ALT may then be selected. Ensure navigation systems are set up correctly prior to attempting to engage NAV mode.

4. AutopilotENGAGE AS DESIRED if flight director commands are appropriate

If unable to restore Flight Director:

5. FD ButtonPRESS to remove Flight Director from PFDs

BOTH ON ADC1, BOTH ON ADC2

BOTH ON ADC1

BOTH ON ADC2

This message is displayed on both PFDs and indicates that both pilot and copilot PFDs are displaying data from the same Air Data Computer. Normally the pilot's side displays ADC 1 information and the copilot's side displays ADC 2 information. Refer to GARMIN G1000 Cockpit Reference Guide and Pilot's Guide for additional information.

1. PFD (displaying data from opposite ADC) SENSOR softkey PRESS
2. ADC1 or ADC 2 softkeySELECT on-side ADC
(ADC1 for Pilot PFD, ADC2 for copilot PFD)
3. PFD DisplaysCONFIRM "BOTH ON ADC 1" or "BOTH ON ADC 2"
message clears on both PFDs
4. If message does not clear, refer to Abnormal Procedures - FAILED AIRSPEED, ALTITUDE,
AND/OR VERTICAL SPEED.

BOTH ON AHRS 1, BOTH ON AHRS 2

BOTH ON AHRS1

BOTH ON AHRS2

This message is displayed on both PFDs and indicates that both pilot and copilot PFDs are displaying data from the same Attitude Heading Reference System. Normally the pilot's side displays AHRS 1 information and the copilot's side displays AHRS 2 information. Refer to GARMIN G1000 Cockpit Reference Guide for additional information.

1. PFD (displaying data from opposite AHRS) SENSOR softkey PRESS
2. AHRS1 or AHRS2 softkey Select on-side AHRS
(AHRS1 for Pilot PFD, AHRS2 for copilot PFD)
3. PFD Displays CONFIRM "BOTH ON AHRS 1" or "BOTH ON AHRS 2"
message clears on both PFDs
4. If message does not clear, refer to Abnormal Procedures - FAILED ATTITUDE AND/OR
HEADING

BOTH ON GPS 1, BOTH ON GPS 2

BOTH ON GPS1

BOTH ON GPS2

This message is displayed on both PFDs and indicates that both pilot and copilot PFDs are displaying data from the same GPS/SBAS receiver. Normally the pilot's side displays GPS 1 and the copilot's side displays GPS 2 and is not pilot selectable. This may be caused by operation outside of SBAS satellite coverage in which case the non-selected GPS is still available in the event the active GPS fails. Refer to GARMIN G1000 Cockpit Reference Guide for additional information.

1. GPS/SBAS Status CHECK
 - a. Select AUX - GPS STATUS page on MFD.
 - b. Select GPS1 then GPS2 softkeys and verify sufficient satellite reception.

USING ADC1 or ADC2 **USING ADC1** **USING ADC2**

This message is displayed on both PFDs and indicates that both PFDs are displaying data from the opposite side air data computer. Normally the pilot's side displays ADC 1 and the copilot's side displays ADC 2. Refer to GARMIN G1000 Cockpit Reference Guide for additional information.

1. PILOT'S PFD SENSOR SoftkeyPRESS
2. PILOT'S PFD ADC1 Softkey.....PRESS
3. PFD Displays CONFIRM "BOTH ON ADC1" message displayed on both PFDs
4. COPILOT'S PFD SENSOR Softkey.....PRESS
5. COPILOT'S PFD ADC2 SoftkeyPRESS
6. PFD Displays CONFIRM "BOTH ON ADC 1" message clears on both PFDs

USING AHRS1 or AHRS2 **USING AHRS1** **USING AHRS2**

This message is displayed on both PFDs and indicates that both PFDs are displaying data from the opposite side Attitude Heading Reference System. Normally the pilot's side displays AHRS 1 and the copilot's side displays AHRS 2. Refer to GARMIN G1000 Cockpit Reference Guide for additional information.

1. PILOT'S PFD SENSOR SoftkeyPRESS
2. PILOT'S PFD AHRS1 SoftkeyPRESS
3. PFD Displays CONFIRM "BOTH ON AHRS1" message displayed on both PFDs
4. COPILOT'S PFD SENSOR Softkey.....PRESS
5. COPILOT'S PFD AHRS2 SoftkeyPRESS
6. PFD DisplaysCONFIRM "BOTH ON AHRS 1" message clears on both PFDs

SYNTHETIC VISION

If SVS displays information inconsistent with G1000 primary flight instrumentation:

On the PFD:

1. PFD softkey.....PRESS
2. SYN VIS softkey.....PRESS
3. SYN TERR keyPRESS
4. SVS is removed from both PFD displays.....VERIFY
Use G1000 primary displays for navigation and aircraft control.

If G1000 operation in display backup mode is required:

Select display backup mode on the G1000 system. When display backup mode is selected, the MFD will initially present a non-SVS (blue sky over solid brown ground) display. SVS will be presented on the backup display within 20 seconds if it was enabled on the PFD when display backup was selected.

TAWS AND GPWS

TAWS or GPWS CAUTION TERRAIN

When a TAWS or GPWS CAUTION occurs, take positive corrective action until the alert ceases. Stop descending or initiate either a climb or a turn, or both as necessary, based on analysis of all available instruments and information.

GPWS CAUTION advisories may also be generated when the aircraft's flaps and landing gear are not in the landing position at low altitudes at groundspeeds less than 157 knots. Ensure the aircraft's landing gear and flaps are in the desired configuration.

TAWS INHIBIT TAWS INH

The TAWS Forward Looking Terrain Avoidance (FLTA) and Premature Descent Alerts (PDA) functions may be inhibited to stop alerting if desired. Refer to GARMIN G1000 Cockpit Reference Guide for additional information.

To Inhibit TAWS:

1. Display the MAP – TAWS-A or MAP – TAWS-B page.
2. TAWS INH or INHIBIT SoftkeyPRESS
3. Verify a TAWS INH annunciation displays on both PFDs and in the lower right corner of the MFD.

To Enable TAWS If Inhibited:

1. Display the MAP – TAWS-A or MAP – TAWS-B page.
2. TAWS INH or INHIBIT SoftkeyPRESS
3. Verify the TAWS INH annunciations are removed from both PFDs and the MFD.

GPWS INHIBIT (TAWS-A Only) GPWS INH

For airplanes equipped with TAWS-A, some GPWS functions may be inhibited to stop alerting if desired. Refer to GARMIN G1000 Cockpit Reference Guide for additional information.

To Inhibit GPWS:

1. Display the MAP – TAWS A page
2. GPWS INH Softkey PRESS
3. Verify a GPWS INH annunciation displays on both PFDs and in the lower right corner of the MFD.

To Enable GPWS if Inhibited:

1. Display the MAP – TAWS A page
2. GPWS INH Softkey PRESS
3. Verify the GPWS INH annunciation is removed from both PFDs and the MFD.

NOTE

The GPWS INHIBIT feature will not inhibit altitude voice callouts or Glideslope/Glidepath deviation alerting.

FLAP OVERRIDE (TAWS-A Only) FLAP OVR

For airplanes equipped with TAWS-A, the GPWS flap configuration alerting function may be inhibited to stop alerting if desired. Refer to GARMIN G1000 Cockpit Reference Guide for additional information.

To Override Flap Alerting:

1. Display the MAP – TAWS A page
2. FLAP OVR Softkey PRESS
3. Verify a FLAP OVR annunciation displays on both PFDs and in the lower right corner of the MFD.

To Enable Flap Alerting if Overridden:

1. Display the MAP – TAWS A page
2. FLAP OVR Softkey PRESS
3. Verify the FLAP OVR annunciation is removed from both PFDs and the MFD.

GLIDESLOPE/GLIDEPATH DEVIATION INHIBIT (TAWS-A Only) **GS INH** or **GP INH**

For airplanes equipped with TAWS-A, the glideslope or glidepath deviation alerting function may be inhibited to stop alerting if desired. Refer to GARMIN G1000 Cockpit Reference Guide for additional information.

To Inhibit Glideslope or Glidepath Alerting:

1. Display the MAP – TAWS A page
2. **GS INH** or **GP INH** Softkey PRESS
3. Verify a **GS INH** or a **GP INH** annunciation displays on both PFDs and in the lower right corner of the MFD.

To Enable Glideslope or Glidepath Alerting if Inhibited:

1. Display the MAP – TAWS A page
2. **GS INH** or **GP INH** Softkey PRESS
3. Verify the **GS INH** or **GP INH** annunciation is removed from both PFDs and the MFD.

NOTE

The **GS INH** or **GP INH** softkeys are only available for selection below 1000' radar altitude with the landing gear DOWN and the aircraft sufficiently below the Glideslope or Glidepath to generate a deviation alert.

TAWS N/A and TAWS FAIL **TAWS N/A** **TAWS FAIL**

1. If the amber **TAWS N/A** status annunciator is displayed on the PFDs and MFD, the system will no longer provide TAWS alerting or display relative terrain and obstacle elevations. The crew must maintain compliance with procedures that ensure minimum terrain and obstacle separation.
2. If the amber **TAWS FAIL** status annunciator is displayed on the PFDs and MFD, the system will no longer provide TAWS alerting or display relative terrain and obstacle elevations. The crew must maintain compliance with procedures that ensure minimum terrain and obstacle separation.

NOTE

The GPWS functions will continue to function if GPWS is available on a Class A TAWS system. Forward Looking Terrain Awareness alerts and Premature Descent Alerts will be unavailable.

GPWS FAIL (TAWS-A only)

(Yellow **GPWS FAIL** on PFD and MFD)

If the amber **GPWS FAIL** status annunciator is displayed on the PFDs and MFD, the G1000 will no longer provide GPWS alerting. The crew must maintain compliance with procedures that ensure minimum terrain separation as well proper aircraft landing gear and flap configuration.

NOTE

Forward Looking Terrain Awareness alerts, Premature Descent Alerts, and Altitude Voice Callouts will continue to function if TAWS is available.

This page intentionally left blank.

Section 4 - Normal Procedures

Table of Contents

| | |
|--|-----------|
| COM RADIO COMMUNICATIONS BEFORE STARTING ENGINES..... | 73 |
| PREFLIGHT INSPECTION | 73 |
| BEFORE ENGINE STARTING | 75 |
| BEFORE TAXI | 76 |
| TAXI..... | 76 |
| BEFORE TAKEOFF (RUN-UP) | 77 |
| BEFORE TAKEOFF (FINAL ITEMS)..... | 78 |
| TAKEOFF | 78 |
| CRUISE WITHIN RVSM AIRSPACE | 78 |
| CLIMB, CRUISE, AND DESCENT..... | 79 |
| ICING FLIGHT | 79 |
| SHUTDOWN AND SECURING | 79 |
| OTHER PROCEDURES | 79 |
| AUTOPILOT OPERATION | 79 |
| VERTICAL MODES | 80 |
| VERTICAL SPEED (VS) MODE | 80 |
| FLIGHT LEVEL CHANGE (FLC) MODE | 80 |
| ALTITUDE HOLD (ALT) MODE, MANUAL CAPTURE | 80 |
| VERTICAL NAVIGATION (VNAV)..... | 81 |
| LATERAL MODES..... | 82 |
| HEADING MODE (HDG) | 82 |
| NAVIGATION (VOR)..... | 82 |
| NAVIGATION (GPS DIRECT TO) | 82 |
| NAVIGATION (GPS OBS Mode) | 83 |

| | |
|---|-----------|
| APPROACHES | 83 |
| ILS | 83 |
| ILS GLIDE SLOPE INOPERATIVE | 85 |
| RNAV (GPS) (LPV or LNAV/VNAV) | 86 |
| RNAV (GPS) (LNAV, LNAV + V) | 87 |
| VOR APPROACH | 89 |
| BACK COURSE (BC) | 91 |
| GO AROUND (GA) | 92 |
| AUTOPILOT COUPLED GO AROUND (GA) (ESP Equipped Airplanes Only) | 94 |
| SYNTHETIC VISION | 95 |

COM RADIO COMMUNICATIONS BEFORE STARTING ENGINES

To obtain an ATC clearance before starting the engines:

1. BAT Switch (Master Switch)ON

Use Pilot's Audio Panel and Com 1 to Obtain ATC Clearance, then:

2. BAT Switch (Master Switch)OFF

PREFLIGHT INSPECTION

The following procedure is in addition to the AFM PREFLIGHT INSPECTION procedure and required only if the airplane is RVSM compliant and will be operated in an RVSM environment.

RIGHT AFT FUSELAGE

1. Right Side Fuselage Skin and Static Ports CHECKED
2. Verify that the static port openings are smooth and round, and that there is no foreign material in the static port openings. Visually inspect the fuselage skin in the RVSM critical region (defined by markings in the vicinity of the static ports) to verify the absence of skin defects, physical damage, or large gaps and steps in the skin surface caused by improperly seated access panels or hatches. Refer to Figure 2 – Right side mirrors the Left.

LEFT AFT FUSELAGE

1. Left Side Fuselage Skin and Static Ports..... CHECKED
2. Verify that the static port openings are smooth and round, and that there is no foreign material in the static port openings. Visually inspect the fuselage skin in the RVSM critical region (defined by markings in the vicinity of the static ports) to verify the absence of skin defects, physical damage, or large gaps and steps in the skin surface caused by improperly seated access panels or hatches. Refer to Figure 2.

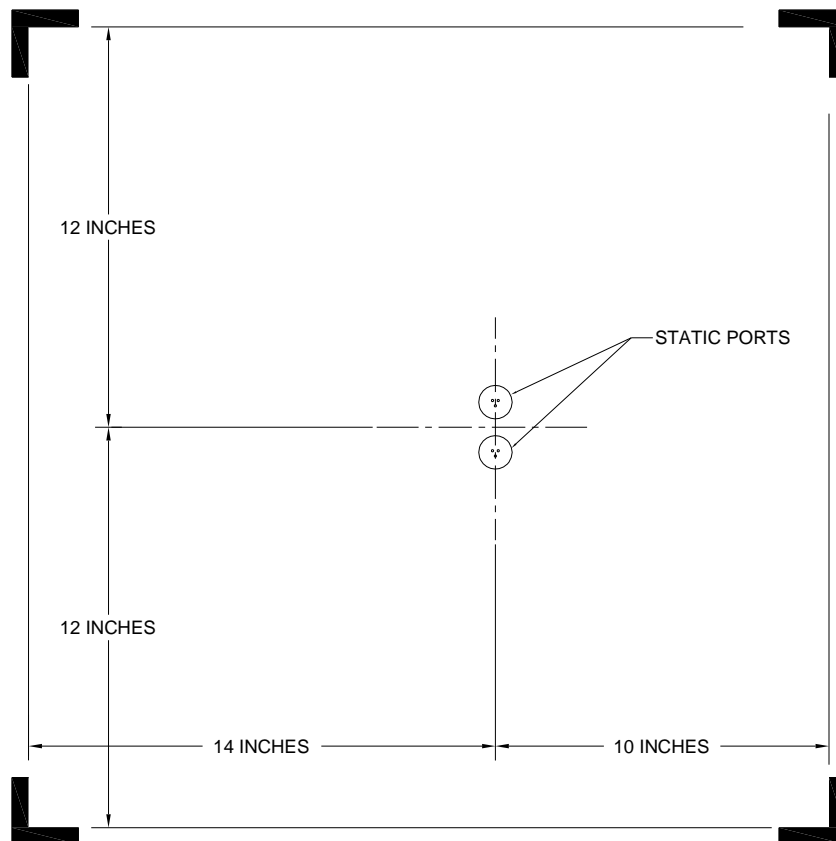
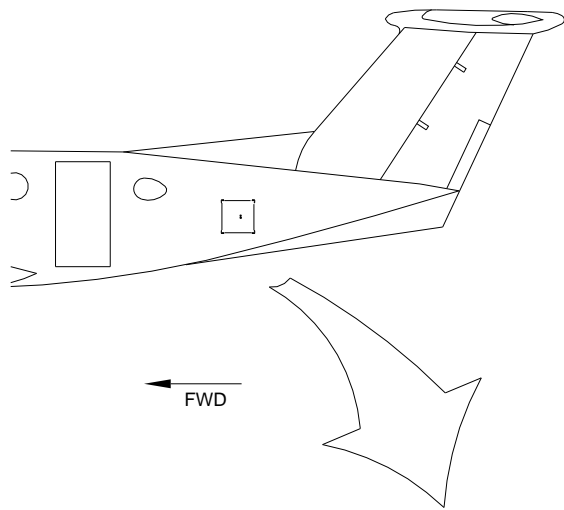

Figure 2, RVSM Critical Region

BEFORE ENGINE STARTING

These procedures should be conducted during the airplane's AFM BEFORE ENGINE STARTING checklist items, after the battery has been turned on and both AHRS have aligned.

NOTE

Autopilot preflight test will not begin until both AHRS have aligned. Autopilot Pre-Flight test begins when the white PFT message is displayed on each PFD. Autopilot Pre-Flight test has successfully completed when the white PFT message extinguishes and the autopilot disconnect tone sounds.

CAUTION

A red PFT or AFCS annunciator indicates a malfunction within the autopilot system. The autopilot, yaw damper, and electric elevator trim will be inoperative. The rudder boost may be inoperative.

1. Automatic Autopilot Preflight Test..... COMPLETE
 - a. Red AFCS Annunciator.....ILLUMINATED DURING AHRS ALIGNMENT
 - b. Red AFCS Annunciator..... EXTINGUISHES When Autopilot Preflight Test Begins
 - c. White PFT Annunciator.....ILLUMINATED (~ 5 Seconds)
 - d. White PFT Annunciator..... EXTINGUISHES when preflight test complete
 - e. Autopilot Disconnect Tone.....SOUNDS

These procedures should be conducted after completing the airplane's AFM BEFORE ENGINE STARTING checklist items.

1. Standby Battery Switch PUSH
[ON] illuminated if Aircraft Battery is OFF,
[ARM] illuminated if Aircraft Battery is ON
2. Standby Attitude Gyro Fail Flag NOT DISPLAYED
(listen for standby altimeter vibrator operation)
3. DatabaseREVIEW FOR VALID OPERATING DATES AND CYCLE NUMBER
4. ENT key on the MFD Control Panel.....PRESS to acknowledge the G1000
database information and activate the selected pilot profile.
5. AUX – Weight Planning.....INPUT LOAD DATA

BEFORE TAXI

These procedures should be conducted after completing the airplane's AFM BEFORE TAXI checklist items before brake release.

1. Standby Attitude Indicator CHECK
 - a. PULL TO CAGE Knob PULL KNOB TO ERECT GYRO
 - b. Instrument Fail Flag NOT DISPLAYED IN INSTRUMENT FACE
 - c. PFD1, PFD2, and Standby Attitude Indicator COMPARE and CROSS CHECK

2. Altimeters SET and CROSS CHECK
PFD 1, PFD 2, Standby Altimeter

If barometric pressure settings on the PFD1 and PFD2 altimeters differ by more than 0.03 in-Hg (1 HPa), the baro display on both PFDs will be amber.

3. Radar Altimeter TEST
 - a. RA TEST Softkey PRESS
(MFD AUX – SYSTEM STATUS Page)
 - b. RA TEST Annunciation ILLUMINATED on PFD1 and PFD2
 - c. RA Display Window 50 feet radar altitude on PFD1 and PFD2
 - d. RA Ground Reference Correlates to 50 feet radar altitude on
PFD 1 and PFD 2 Altimeter displays
 - e. RA TEST Softkey PRESS TO STOP TEST
 - f. PFD1 and PFD2 Radar Altimeter Displays 0 Feet
 - g. RA Ground Reference Correlates to 0 feet radar altitude on
PFD 1 and PFD 2 Altimeter displays
 - h. RA TEST Annunciation REMOVED from PFD1 and PFD2

TAXI

The following procedure should be accomplished while the aircraft is taxiing and prior to conducting the airplane's AFM BEFORE TAKEOFF (RUNUP) checklist.

NOTE

Taxiing the aircraft before a valid GPS position has been acquired can cause attitude and/or heading display to indicate a failed condition. Interference from GPS repeaters or magnetic anomalies can cause an intermittent loss of attitude and heading displays while the aircraft in on the ground.

1. Flight Instruments CHECK
 - a. Compare attitude displayed by PFD1, PFD2, and Standby Attitude Indicator.
 - b. Verify the correct barometric pressure is set in the PFD1, PFD2, and Standby Altimeters.
 - c. Compare altitude displayed by PFD1, PFD2, and Standby Altimeter. Cross-check and verify the altitudes agree within 75 feet.
 - d. Compare heading displayed by PFD1, PFD2, and Magnetic Compass.

NOTE

The standby compass is erratic during windshield anti-ice and/or air conditioner operation. Windshield anti-ice and air conditioner must be OFF for heading verification check.

- e. Verify turn rate and slip indicator display appropriately.

BEFORE TAKEOFF (RUN-UP)

The following procedures supersede the same procedures in the airplane's AFM BEFORE TAKEOFF (RUNUP) checklist items.

1. Yaw Damp..... CHECK
 - a. Yaw DampON
 - b. Rudder Pedals..... CHECK FOR ADDED RESISTANCE
 - c. AP/YD DISC/TRIM INTRPT Button..... PRESS
 - d. [RUD BOOST OFF]..... ILLUMINATES
 - e. Yaw Damp VERIFY DISCONNECTED
 - f. Repeat Items a through c for copilot's side
 - g. Rudder Boost Switch..... OFF
[RUD BOOST OFF] - ILLUMINATED
 - h. Rudder Boost Switch..... RUDDER BOOST
[RUD BOOST OFF] - EXTINGUISHED

2. Electric Elevator Trim Control CHECK
 - a. Pilot's Control Wheel
 - Left and Right Segments..... ACTUATE INDIVIDUALLY
(Verify there is no elevator tab wheel movement)
 - Left and Right Segments..... ACTUATE TOGETHER
(Verify proper elevator tab wheel movement)
 - With Elevator Tab Wheel in Motion,
AP/YD DISC / TRIM INTRPT Button..... PRESS AND HOLD
(verify elevator tab wheel motion stops)
 - Manually Operate Elevator Tab Wheel ... VERIFY Pitch Trim Servo is Not Engaged

 - b. Copilot's Control Wheel (If Installed)
 - Left and Right Segments..... ACTUATE INDIVIDUALLY
(Verify there is no elevator tab wheel movement)
 - Left and Right Segments..... ACTUATE TOGETHER
(Verify proper elevator tab wheel movement)

- With Elevator Tab Wheel in Motion,
AP/YD DISC / TRIM INTRPT Button..... PRESS AND HOLD
(verify elevator tab wheel motion stops)
 - Pilot's Trim Override..... CHECK
Activate the copilot's Pitch Trim Switches nose down. Verify elevator tab wheel is moving nose down. While the tab wheel is moving in the DN direction, activate the pilot's Pitch Trim Switches nose up. Verify the elevator tab wheel begins to move in the UP direction. Release both pilot's and copilot's Pitch Trim switches and reset elevator tab as required.
 - Manually Operate Elevator Tab WheelVERIFY Pitch Trim Servo is Not Engaged
- c. Press GA Button on Left power lever VERIFY FD Command Bars show Takeoff Attitude 'TO // TO' is Annunciated in Mode Window on Both PFDs

BEFORE TAKEOFF (FINAL ITEMS)

The following procedures supersede the same procedures in the airplane's AFM BEFORE TAKEOFF (FINAL ITEMS) checklist items.

1. V_1 , V_2 , Minimum Takeoff PowerSET OR CONFIRM

These procedures should be conducted after completing the airplane's AFM BEFORE TAKEOFF (FINAL ITEMS) checklist.

2. PFD Attitude and HeadingNORMAL
3. GPS Position..... VALID, 'LOI' NOT ANNUNCIATED on HSI
4. Standby Attitude Indicator ERECT and NORMAL, Fail Flag not in view

TAKEOFF

This procedure should be conducted after brake release during the takeoff roll but before becoming airborne.

1. Verify correspondence of PFD airspeed display and standby airspeed.

CRUISE WITHIN RVSM AIRSPACE

1. Altimeters CROSS-CHECK
Maximum Difference: 200 Feet
Ensure Matched barometric pressure settings (29.92 inHg, STD BARO, or 1013 mb).
2. Altitude RECORD as Required
Record pilot, copilot and standby altimeter readings upon entering RVSM airspace and as required thereafter while in RVSM airspace for contingency situations.
3. Autopilot ALT Mode.....Maximum Altitude Deviation: +/- 65 Feet
During normal operations, the ADC coupled to the autopilot will supply altitude data to the active transponder.

CLIMB, CRUISE, AND DESCENT

Disengage autopilot and yaw damper and re-trim the airplane in roll and/or yaw, if slight dutch roll activity is observed. Re-engage the autopilot and yaw damper after trimming the airplane.

ICING FLIGHT

IN FLIGHT

WARNING

DUE TO DISTORTION OF THE WING AIRFOIL, ICE ACCUMULATION ON THE LEADING EDGES CAN CAUSE A SIGNIFICANT LOSS IN RATE OF CLIMB AND IN SPEED PERFORMANCE, AS WELL AS INCREASES IN STALL SPEED. EVEN AFTER CYCLING THE DEICE BOOTS, THE ICE ACCUMULATION REMAINING ON THE BOOTS AND UNPROTECTED AREAS OF THE AIRPLANE CAN CAUSE LARGE PERFORMANCE LOSSES. FOR THE SAME REASON, THE AURAL STALL WARNING SYSTEM MAY NOT BE ACCURATE AND SHOULD NOT BE RELIED UPON. UNDER THESE CONDITIONS, ESP AND AUTOPILOT UNDERSPEED PROTECTION MAY ALSO NOT BE ACCURATE AND SHOULD NOT BE RELIED UPON.

SHUTDOWN AND SECURING

These procedures should be conducted after the Battery and Generator Switches have been turned OFF in the AFM Shutdown and Securing checklist, and before the flight crew vacates the cockpit.

1. Standby Battery SwitchPRESS OFF
 - a. Standby Battery Switch..... [ARMED] and [ON] EXTINGUISHED
 - b. Standby attitude fail flagDISPLAYED
 - c. Standby altimeter vibrator should not be heard (BAT – MASTER SWITCH OFF).

OTHER PROCEDURES

AUTOPILOT OPERATION

Autopilot/Flight Director mode annunciations on the PFDs displayed in green indicate active autopilot/flight director modes. Annunciations displayed in white indicate armed autopilot/flight director modes. Normal mode transitions will flash inverse video green/black for 10 seconds before becoming steady green. Abnormal mode transitions will flash amber for 10 seconds before the default mode is annunciated as the active mode.

Default autopilot/flight director modes are Pitch (PIT) and Roll (ROL) modes.

The XFR button on the mode control panel selects the navigation, attitude, and air data inputs the autopilot / flight director uses. Pressing the XFR button transfers these selections to the opposite side and causes the autopilot / flight director to drop selected lateral and vertical modes and engage the default PIT and ROL modes. The pilot must re-select the desired modes.

VERTICAL MODES

VERTICAL SPEED (VS) MODE

1. Altitude Preselect.....SET to Desired Altitude
2. Press VS ButtonGREEN 'VS', White 'ALTS' annunciated on PFD
3. Vertical Speed Reference.....ADJUST using UP / DN Wheel
4. Green 'ALT'.....VERIFY UPON ALTITUDE CAPTURE

FLIGHT LEVEL CHANGE (FLC) MODE

1. Altitude Preselect.....SET to Desired Altitude
2. Press FLC ButtonGREEN 'FLC', White 'ALTS' annunciated on PFD
3. AIRSPEED Reference.....ADJUST using UP / DN Wheel
4. Green 'ALT'.....VERIFY UPON ALTITUDE CAPTURE

NOTE

If the altitude preselect is not changed before selecting FLC, the autopilot may re-capture the current altitude immediately after entering FLC mode. Always ensure that the altitude preselect is adjusted prior to selecting FLC.

Pressing the SPD button while in FLC Mode toggles the airspeed reference between KIAS and Mach. FLC will automatically transition from Mach to KIAS reference during a descent when the current Mach reference equals 250 KIAS. FLC will not automatically transition from KIAS to a Mach reference during a climb.

ALTITUDE HOLD (ALT) MODE, MANUAL CAPTURE

1. At the desired altitude.....PRESS ALT Button on Mode Controller
2. Green 'ALT'.....VERIFY on PFD

If climbing or descending when the ALT button is pressed, the aircraft will overshoot the reference altitude and then return to it. The amount of overshoot will depend on the vertical speed when the ALT button is pressed.

VERTICAL NAVIGATION (VNAV)

VNAV Descent

Vertical navigation will only function when the navigation source is GPS navigation. VNAV will not function if the navigation source is VOR, Localizer, or ADF. The airplane's heading must be within 75° of the desired GPS course and within 10 NM cross track error in order for VNAV to function.

VNAV functions only for enroute and terminal descents. Vertical navigation is not available during climbs or descents between the final approach fix (FAF) and the missed approach point (MAP). Refer to the G1000 Cockpit Reference Guide and Pilot's Guide for additional information.

1. Once clearance from ATC has been received RESET Altitude Preselect to the vertical clearance limit.
2. VNV Button PRESS within 5 minutes of the top of descent (TOD)

NOTE

If the VNV button is pressed more than 5 minutes before the TOD or the altitude preselect is not reset to a lower altitude, VPTH will begin to flash inverse video, white/black, when the aural alert 'Vertical Track' annunciation sounds.

Pressing the VNV button and/or resetting the altitude preselect to a lower altitude cancels the flashing and the AFCS will capture and track the vertical profile.

If VNV button is not pressed, or the altitude preselect is not reset to a lower altitude, VPTH stops flashing at the TOD and the airplane will remain in ALT mode and not descend.

ALTV will be the armed vertical mode during the descent if the altitude preselect is set to a lower altitude than the VNAV reference altitude. This indicates the autopilot / flight director will capture the VNAV altitude reference. ALTS will be the armed mode during the descent if the altitude preselect is set at or above the VNAV reference altitude indicating that the autopilot / flight director will capture the altitude preselect altitude reference.

Vertical DIRECT TO

To descend from the present position to a waypoint:

1. Altitude Preselect RESET
2. VNV Button PRESS
3. Waypoint SELECT desired waypoint
4. VNV \rightarrow Softkey (MFD Flight Plan Page) PRESS
5. Vertical DIRECT TO ACTIVATE

LATERAL MODES

HEADING MODE (HDG)

1. HDG Knob PUSH to synch heading bug to current heading
2. HDG BUTTON PUSH , HDG mode annunciated
3. HDG Knob Rotate to set heading bug to desired heading

NAVIGATION (VOR)

1. Navigation Source. SELECT VOR1 or VOR2 using CDI softkey on PFD
2. Course Pointer..... SET using CRS knob
3. Intercept Heading ESTABLISH in HDG or ROL mode
4. Mode Controller PRESS NAV on mode controller
5. VOR will be annunciated in WHITE if the mode is armed or in GREEN if the VOR is the active lateral mode.

NOTE

If the Course Deviation Indicator (CDI) is greater than one dot from center, the autopilot will arm the NAV mode and indicate VOR in white on the PFD. The pilot must ensure that the current heading will result in a capture of the selected course. If the CDI is one dot or less from center, the autopilot will enter the capture mode when the NAV button is pressed and annunciate VOR in green on the PFD.

NAVIGATION (GPS DIRECT TO)

1. Navigation Source SELECT GPS Using the CDI Softkey on PFD
2. Select Waypoint..... PRESS the \rightarrow button on the PFDs or GCU
From the DIRECT TO page, activate DIRECT TO a waypoint.
3. Mode Controller SELECT NAV on mode controller
GPS will be annunciated in GREEN on the PFDs

NAVIGATION (GPS OBS Mode)

1. Navigation SourceSELECT GPS using the CDI softkey on PFD
2. Select Waypoint..... PRESS the \rightarrow button on the PFDs or GCU
From the DIRECT TO page, activate DIRECT TO a waypoint.
3. OBS Softkey ON PFD, PRESS OBS softkey
4. Course Pointer.....SET using CRS knob
5. Intercept HeadingESTABLISH in HDG or ROL mode
6. Mode ControllerSELECT NAV on mode controller
7. GPS will be annunciated in WHITE if the mode is armed or in GREEN if the GPS is the active lateral mode.

NOTE

If the Course Deviation Indicator (CDI) is greater than one dot from center, the autopilot will arm the NAV mode and indicate GPS in white on the PFD. The pilot must ensure that the current heading will result in a capture of the selected course. If the CDI is one dot or less from center, the autopilot will enter the capture mode when the NAV button is pressed and annunciate GPS in green on the PFD.

APPROACHES

The G1000 is capable of performing many tasks for the pilot to reduce pilot workload during the approach and landing phases of flight. The G1000 system references the Flight Plan to predict the pilot's intended actions. Time permitting, the pilot should keep the Flight Plan updated with the destination airport and the instrument approach to be flown. This will keep the G1000 from performing tasks associated with the approach procedures entered in the flight plan if the approach plan changes.

ILS

1. Load the approach into the Active Flight Plan..... VERIFY the G1000 tunes the proper ILS frequency
2. Approach MinimumsSET on TMR/REF page (if not already set)

If Flying Vectors-To-Final:

3. Airplane on Vectors-To-Final
 - a. Mode Control PanelPRESS HDG to fly ATC radar vectors
 - b. PROC button on PFDs or MFD.....SELECT 'ACTIVATE VECTORS-TO-FINAL'

NOTE

SUSP may annunciate on the HSI when Vectors-To-Final is selected. The flight plan will automatically un-suspend when the airplane intercepts and turns inbound on the final approach course. When automatic flight plan waypoint sequencing resumes, SUSP will extinguish.

- c. HSI CDI VERIFY CDI automatically changes to LOC
Course pointer slews to the front course
- d. Pathways..... AS DESIRED
- e. Mode Control Panel PRESS APR, Verify LOC and GS armed

If Flying Full Approach Including Transition:

- 3. Airplane cleared to an initial approach fix
 - a. ACTIVATE THE APPROACH from the PROC page,
Or
ACTIVATE a DIRECT TO (→) the IAF
 - b. HSI CDI SELECT GPS Nav Source
 - c. Mode Control Panel PRESS NAV (GPS Mode)
 - d. Mode Control Panel PRESS APR, Verify LOC and GS armed

NOTE

The airplane will navigate in GPS mode throughout the intermediate portion of the approach procedure. When the airplane is inbound towards the final approach course, the CDI will automatically switch from GPS navigation to LOC navigation.

- e. Pathways..... AS DESIRED
- f. VERIFY Course pointer slews to the front course
- 4. Established inbound on Final Approach Course SET Missed Approach Altitude
In Altitude Preselect
- 5. Airspeed.....MAINTAIN 120 KIAS OR GREATER (Recommended)
- 6. VERIFY Airplane Captures and Tracks LOC and GS
- 7. At Decision Altitude (DA),
 - a. A/P Y/D DISC TRIM INTRPT SwitchPRESS
Continue visually for a normal landing
Or
 - b. GO AROUND button
(on left power lever)PRESS, Execute Go Around Procedure

NOTE

For TAWS-A equipped aircraft: When executing a missed approach from an ILS approach, occasional Glideslope Deviation cautions may be received while establishing the missed approach climb, even if the aircraft is not below the ILS glideslope. This is caused by transitioning through ILS glideslope side lobe signals. If the Glideslope Deviation alert annunciates during the initial portion of the go-around, continue to execute the go-around procedure and fly the appropriate missed approach procedure.

ILS GLIDE SLOPE INOPERATIVE

- 1. Load the approach into the Active Flight Plan..... VERIFY the G1000 tunes the proper ILS frequency
- 2. Approach Minimums..... SET on TMR/REF page (if not already set)

If Flying Vectors-To-Final:

- 3. Airplane on Vectors-To-Final
 - a. Mode Control Panel PRESS HDG to fly ATC radar vectors
 - b. PROC button on PFDs or GCU SELECT 'ACTIVATE VECTORS-TO-FINAL'

NOTE

SUSP may annunciate on the HSI when Vectors-To-Final is selected. The flight plan will automatically un-suspend when the airplane intercepts and turns inbound on the final approach course. When automatic flight plan waypoint sequencing resumes, SUSP will extinguish.

- c. HSI CDI VERIFY CDI automatically changes to LOC
Course pointer slews to the front course
- d. Pathways..... AS DESIRED
- e. Mode Control Panel PRESS NAV, verify LOC armed

Pressing the NAV button will arm the autopilot / flight director to capture Localizer and prevent Glideslope from arming or capturing if the glideslope is inoperative or out of service.

If Flying Full Approach Including Transition:

- 3. Airplane cleared to an initial approach fix
 - a. ACTIVATE THE APPROACH from the PROC page,
Or
ACTIVATE a DIRECT TO (➔) the IAF
 - b. HSI CDI SELECT GPS Nav Source
 - c. Mode Control Panel PRESS NAV (GPS Mode)

NOTE

The airplane will navigate in GPS mode throughout the intermediate portion of the approach procedure. When the airplane is inbound towards the final approach course, the CDI will automatically switch from GPS navigation to LOC navigation.

- d. Pathways..... AS DESIRED
- e. VERIFY Course pointer slews to the front course

4. Established inbound on Final Approach Course (FAF Active Waypoint)
 - a. VERIFY Course Pointer is set to the final approach course
 - b. VERIFY LOC is annunciated on the HSI
5. Airspeed.....MAINTAIN 120 KIAS OR GREATER (Recommended)
6. At the FAF.....Use desired vertical mode to fly the approach's vertical profile
Use Altitude Preselect to level off at intermediate altitudes and at the MDA

NOTE

It is recommended to descend at 1000 ft/min or less. Descending at a higher rate or reaching MDA too far before the Visual Descent Point (VDP) could cause TAWS or GPWS alerts. If a TAWS or GPWS WARNING is issued, immediately follow the TAWS OR GPWS WARNING procedure in the EMERGENCY PROCEDURES Section of this AFMS.

7. After Leveling at MDA.....SET Missed Approach Altitude In Altitude Preselect

RNAV (GPS) (LPV or LNAV/VNAV)

1. Load the approach into the Active Flight Plan.
2. Approach Minimums.....SET ON TMR/REF page (if not already set)

If Flying Vectors-To-Final:

3. Airplane on Vectors-To-Final
 - a. Mode Control PanelPRESS HDG to fly ATC radar vectors
 - b. PROC button on PFDs or MFD.....SELECT 'ACTIVATE VECTORS-TO-FINAL'

NOTE

SUSP may annunciate on the HSI when Vectors-To-Final is selected. The flight plan will automatically un-suspend when the airplane intercepts and turns inbound on the final approach course. When automatic flight plan waypoint sequencing resumes, SUSP will extinguish.

- c. VERIFY Course pointer slews to the front course
- d. Pathways..... AS DESIRED
- e. Mode Control Panel PRESS APR, Verify GPS and GP armed

If Flying Full Approach Including Transition:

3. Airplane cleared to an initial approach fix
 - a. ACTIVATE THE APPROACH from the PROC page,
Or
ACTIVATE a DIRECT TO (-D>) the IAF
 - b. HSI CDI SELECT GPS Nav Source
 - c. Mode Control Panel PRESS APR, Verify GPS mode active, GP armed
 - d. Pathways..... AS DESIRED
 - e. VERIFY Course pointer slews to the front course

4. Established inbound on Final Approach Course
 - a. VERIFY Course Pointer is set to the final approach course
 - b. VERIFY LPV or L/VNAV is annunciated on the HSI
 - c. VERIFY GP Indicator Displays
 - d. VERIFY SUSP is not displayed on HSI
 - e. SET Missed Approach Altitude In Altitude Preselect
5. Airspeed..... MAINTAIN 120 KIAS OR GREATER (Recommended)
6. VERIFY..... Airplane Captures and Tracks GPS Course and GP
7. At Decision Altitude (DA):
 - a. A/P Y/D DISC TRIM INTRPT Switch PRESS
Continue visually for a normal landing
Or
 - b. GO AROUND button
(on left power lever)PRESS, Execute Go Around Procedure

RNAV (GPS) (LNAV, LNAV + V)

1. Load the approach into the Active Flight Plan.
2. Approach MinimumsSET ON TMR/REF page (if not already set)

If Flying Vectors-To-Final:

3. Airplane on Vectors-To-Final
 - a. Mode Control PanelPRESS HDG to fly ATC radar vectors
 - b. PROC button on PFDs or MFD.....SELECT 'ACTIVATE VECTORS-TO-FINAL'

NOTE

SUSP may annunciate on the HSI when Vectors-To-Final is selected. The flight plan will automatically un-suspend when the airplane intercepts and turns inbound on the final approach course. When automatic flight plan waypoint sequencing resumes, SUSP will extinguish.

- c. VERIFY Course pointer slews to the inbound course
- d. Pathways..... AS DESIRED
- e. Mode Controller..... PRESS APR Button
GPS will be the active lateral mode,
GP will ARM if the procedure provides a glidepath

If Flying Full Approach Including Transition:

- 3. Airplane cleared to an initial approach fix
 - a. ACTIVATE THE APPROACH from the PROC page,
Or
ACTIVATE a DIRECT TO (→) the IAF
 - b. HSI CDI SELECT GPS Nav Source
 - c. Mode Controller..... PRESS APR Button
GPS will be the active lateral mode,
GP will ARM if the procedure provides a glidepath
 - d. Pathways..... AS DESIRED

- 4. Established inbound on Final Approach Course (FAF Active Waypoint)
 - a. VERIFY Course Pointer is set to the final approach course
 - b. VERIFY LNAV+V or LNAV is annunciated on the HSI
 - c. VERIFY GP Deviation Scale Displays (if applicable)
 - d. PRESELECT Minimum Descent Altitude (MDA)
- 5. Airspeed..... MAINTAIN 120 KIAS OR GREATER (Recommended)

NOTE

Some RNAV (GPS) approaches provide a vertical descent angle as an aid in flying a stabilized approach. These approaches are NOT considered Approaches with Vertical Guidance (APV). Approaches that are annunciated on the HSI as LNAV or LNAV+V are considered Non-precision Approaches (NPA) and are flown to an MDA even though vertical glidepath (GP) information may be provided.

6. At the FAF..... Descend via GP if LNAV+V approach
 Use desired vertical mode to fly the approach's vertical profile if LNAV approach
 Use Altitude Preselect to level off at intermediate altitudes and at the MDA

NOTE

It is recommended to descend at 1000 ft/min or less. Descending at a higher rate or reaching MDA too far before the Visual Descent Point (VDP) could cause TAWS or GPWS alerts. If a TAWS or GPWS WARNING is issued, immediately follow the TAWS OR GPWS WARNING procedure in the EMERGENCY PROCEDURES Section of this AFMS.

CAUTION

The autopilot/flight director will not capture ALT if descending in GP mode.

7. Level airplane in ALT mode at MDA..... PRESS NAV button 200 ft above MDA
 If airplane is descending via GP, GP will extinguish and PIT mode will be active and airplane will capture MDA.
8. AFTER LEVELING AT MDA.....SET Missed Approach Altitude In Altitude Preselect

VOR APPROACH

1. Load the approach into the Active Flight Plan..... VERIFY the G1000 tunes the proper VOR frequency
2. Approach MinimumsSET ON TMR/REF page (if not already set)

If Flying Vectors-To-Final:

3. Airplane on Vectors-To-Final
 - a. Mode Control PanelPRESS HDG to fly ATC radar vectors
 - b. PROC button on PFDs or GCUSELECT 'ACTIVATE VECTORS-TO-FINAL'

NOTE

SUSP may annunciate on the HSI when Vectors-To-Final is selected. The flight plan will automatically un-suspend when the airplane intercepts and turns inbound on the final approach course. When automatic flight plan waypoint sequencing resumes, SUSP will extinguish.

- c. HSI CDIPRESS until VOR navigation source
 To be used for the approach displays
- d. Course Pointer Set to inbound course (if not already set)
- e. Mode Control PanelPRESS APR, verify VAPP armed

If Flying Full Approach Including Transition:

3. Airplane cleared to an initial approach fix:
 - a. ACTIVATE THE APPROACH from the PROC page,
Or
ACTIVATE a DIRECT TO (→) the IAF
 - b. HSI CDI SELECT GPS
 - c. Mode Control Panel PRESS NAV (GPS mode)
 - d. Pathways..... AS DESIRED
 - e. When Established Inbound to the FAF PRESS CDI softkey
until VOR navigation source to be used for the approach displays
(Autopilot / Flight Director Mode will automatically change to ROL)
 - f. Course Pointer Set to inbound course (if not already set)
 - g. Mode Control Panel PRESS APR, verify VAPP active or armed
4. Established Inbound on Final Approach Course:
 - a. VERIFYCourse Pointer is set to the inbound course
 - b. VERIFYVOR is annunciated on the HSI

NOTE

If the Course Deviation Indicator (CDI) is greater than one dot from center, the autopilot will arm the VAPP mode and indicate VAPP in white on the PFD. The pilot must ensure that the current heading will result in a capture of the selected course. If the CDI is one dot or less from center, the autopilot will enter the capture mode when the APR button is pressed and annunciate VAPP in green on the PFD.

5. Airspeed.....MAINTAIN 120 KIAS OR GREATER (Recommended)
6. At the FAF.....Use desired vertical mode to fly the approach's vertical profile
Use Altitude Preselect to level off at intermediate altitudes and at the MDA

NOTE

It is recommended to descend at 1000 ft/min or less. Descending at a higher rate or reaching MDA too far before the Visual Descent Point (VDP) could cause TAWS or GPWS alerts. If a TAWS or GPWS WARNING is issued, immediately follow the TAWS OR GPWS WARNING procedure in the EMERGENCY PROCEDURES Section of this AFMS.

7. AFTER LEVELING AT MDA.....SET Missed Approach Altitude In Altitude Preselect

BACK COURSE (BC)

- 1. Load the approach into the Active Flight Plan..... VERIFY the G1000 tunes the proper LOC frequency
- 2. Approach Minimums.....SET ON TMR/REF page (if not already set)

If Flying Vectors-To-Final:

- 3. Airplane on Vectors-To-Final
 - a. Mode Control Panel PRESS HDG to fly radar vectors
 - b. PROC button on PFDs or MFD.....SELECT 'ACTIVATE VECTORS-TO-FINAL'

NOTE

SUSP may annunciate on the HSI when Vectors-To-Final is selected. The flight plan will automatically un-suspend when the airplane intercepts and turns inbound on the final approach course. When automatic flight plan waypoint sequencing resumes, SUSP will extinguish.

- c. HSI CDI PRESS until LOC Navigation Source to be used for the Approach Displays
- d. VERIFYCourse Pointer is Set to the Front Course
- e. Mode Control PanelPRESS BC
Verify BC mode is armed

IF Flying Full Approach Including Transition:

- 3. Airplane cleared to an initial approach fix:
 - a. ACTIVATE THE APPROACH from the PROC page,
Or
ACTIVATE a DIRECT TO (➔) the IAF
 - b. HSI CDI SELECT GPS
 - c. Mode Control Panel PRESS NAV (GPS Mode)
 - d. Pathways..... AS DESIRED
 - e. When Established Inbound to the FAF PRESS CDI softkey until LOC navigation source to be used for the approach displays (Autopilot / Flight Director Mode will automatically change to ROL)
 - f. VERIFY Course Pointer is set to the Front Course
 - g. Mode Control PanelPRESS BC
Verify BC mode is armed or active
- 4. Established inbound on Final Approach Course:
 - a. VERIFY Course Pointer is set to the front course
 - b. VERIFY LOC is annunciated on the HSI

NOTE

If the Course Deviation Indicator (CDI) is greater than one dot from center, the autopilot will arm the BC mode and indicate BC in white on the PFD. The pilot must ensure that the current heading will result in a capture of the selected course. If the CDI is one dot or less from center, the autopilot will enter the capture mode when the APR button is pressed and annunciate BC in green on the PFD.

- 5. Airspeed.....MAINTAIN 120 KIAS OR GREATER (Recommended)
- 6. At the FAF.....Use desired vertical mode to fly the approach’s vertical profile
Use Altitude Preselect to level off at intermediate altitudes and at the MDA

NOTE

It is recommended to descend at 1000 ft/min or less. Descending at a higher rate or reaching MDA too far before the Visual Descent Point (VDP) could cause TAWS or GPWS alerts. If a TAWS or GPWS WARNING is issued, immediately follow the TAWS OR GPWS WARNING procedure in the EMERGENCY PROCEDURES Section of this AFMS.

- 7. AFTER LEVELING AT MDA.....SET Missed Approach Altitude In Altitude Preselect

GO AROUND (GA)

- 1. Control Wheel..... GRASP FIRMLY
- 2. GO AROUND button (left power lever) PUSH – Verify GA // GA on PFD
in lateral and vertical mode fields
- 3. Rotate to Go Around attitude..... Follow Flight Director Command Bars
- 4. Balked Landing..... EXECUTE
- 5. Mode Control Panel..... PRESS NAV to Fly Published Missed Approach Procedure
PRESS HDG to Fly ATC Assigned Missed Approach Heading

NOTE

The pilot is responsible for initial missed approach guidance in accordance with published procedure. The G1000 may not provide correct guidance until the aircraft is established on a defined leg of the procedure.

- 6. Altitude Preselect.....VERIFY Set to appropriate altitude

At An Appropriate Safe Altitude:

- 7. Mode Control Panel.....AP to Engage Autopilot

NOTE

When the GA button is pressed, the Flight Director command bars will command 8° nose up and wings level, the HSI nav source automatically switches to GPS, the flight plan sequences to the first published missed approach leg, and automatic leg sequencing resumes. The autopilot will disconnect if the ESP option is not installed. If ESP is installed, the autopilot will not disconnect with a GA button press. The AFCS will fly the published missed approach procedure once the aircraft is established on a segment of the missed approach procedure, the autopilot is engaged, and NAV mode is selected.

The flight plan can only contain one approach procedure at a time. If the pilot attempts to load another instrument approach at this time, the airplane will depart from the missed approach procedure and turn directly towards the first waypoint in the new approach. Do not attempt to load or activate a new approach while flying the missed approach procedure until ready to fly the new approach.

Recommended Procedures Following a Missed Approach:

1. To repeat the instrument approach procedure currently loaded into the flight plan:
 - a. Activate Vectors-To-Final if being radar vectored by ATC,

Or

 - b. If flying the entire instrument approach procedure, activate a DIRECT TO the desired initial waypoint. Follow the appropriate procedure for the instrument approach being flown.

2. To proceed to an alternate airport (This procedure will allow the pilot to enter the route to the alternate before leaving the missed approach holding fix):
 - a. Highlight the first enroute waypoint in the flight plan
 - b. Begin entering waypoints in the desired route order. Do not attempt to load a new approach at this time.
 - c. CLR all waypoints after the last waypoint in the route to the alternate and the currently loaded instrument approach header.
 - d. When ready to proceed to the alternate, highlight the first enroute waypoint in the route to the alternate airport. ACTIVATE a DIRECT TO that waypoint.
 - e. When enroute to the alternate, a new instrument approach may be loaded into the flight plan.

AUTOPILOT COUPLED GO AROUND (GA) (ESP Equipped Airplanes Only)

1. Control Wheel..... GRASP FIRMLY
2. GO AROUND button (left power lever) PUSH – Verify GA // GA on PFD in lateral and vertical mode fields, **autopilot will not disengage.**
3. Autopilot..... VERIFY airplane pitches up following flight director command bars
4. Balked Landing..... EXECUTE
5. Mode Control Panel..... PRESS NAV to Fly Published Missed Approach Procedure
PRESS HDG to Fly ATC Assigned Missed Approach Heading

NOTE

The pilot is responsible for initial missed approach guidance in accordance with published procedure. The G1000 may not provide correct guidance until the airplane is established on a defined leg of the procedure.

6. Altitude Preselect..... VERIFY Set to appropriate altitude

NOTE

In ESP equipped airplanes, when the GA button is pressed the Flight Director command bars will command 8° nose up and wings level, the HSI nav source automatically switches to GPS, the flight plan sequences to the first published missed approach leg, and automatic leg sequencing resumes. The autopilot will remain engaged, and fly the published missed approach procedure once the airplane is established on a segment of the missed approach procedure and NAV mode is selected.

The flight plan can only contain one approach procedure at a time. If the pilot attempts to load another instrument approach at this time, the airplane will depart from the missed approach procedure and turn directly towards the first waypoint in the new approach. Do not attempt to load or activate a new approach while flying the missed approach procedure until ready to fly the new approach.

Recommended Procedures Following a Missed Approach:

1. To repeat the instrument approach procedure currently loaded into the flight plan:
 - a. Activate Vectors-To-Final if being radar vectored by ATC,

Or

 - b. If flying the entire instrument approach procedure, activate a DIRECT TO the desired initial waypoint. Follow the appropriate procedure for the instrument approach being flown.
2. To proceed to an alternate airport (This procedure will allow the pilot to enter the route to the alternate before leaving the missed approach holding fix):
 - a. Highlight the first enroute waypoint in the flight plan
 - b. Begin entering waypoints in the desired route order. Do not attempt to load a new approach at this time.
 - c. CLR all waypoints after the last waypoint in the route to the alternate and the currently loaded instrument approach header.
 - d. When ready to proceed to the alternate, highlight the first enroute waypoint in the route to the alternate airport. ACTIVATE a DIRECT TO that waypoint.
 - e. When enroute to the alternate, a new instrument approach may be loaded into the flight plan.

SYNTHETIC VISION

Use of Pathways

If Synthetic Terrain is displayed on the PFD, the Pathways may be used to assist the pilot's awareness of the programmed lateral and vertical navigation path. The following sections describe the basic use of the Pathways in various flight segments. For more detailed information, consult the G1000 Pilot's Guide.

Departure

Prior to departure, load and activate the desired flight plan into the G1000 FMS, set the initial altitude on the G1000 altitude selector and select GPS on the HSI display just as you would without the SVS system.

The programmed flight path will be displayed as a series of magenta boxes along the path at the flight plan altitude subject to the following conditions;

- If the first segment of the flight plan is a heading to altitude leg, the Pathway will not be displayed for that segment. The first Pathway segment displayed will be the first GPS course leg.
- The Pathway must be within the SVS field of view of 30 degrees left and 35 degrees right. If the programmed path is outside that field of view, the Pathways will not be visible on the display until the aircraft has turned toward the course.
- The Pathway will be displayed at either the altitude selected on the G1000 selector OR the altitude published for the procedure (e.g. SID) WHICHEVER IS HIGHER.

After departure, the primary aircraft control must be by reference to the primary aircraft instruments. The SVS and Pathway displays should be used to aid in awareness of the terrain and programmed flight path.

Prior to intercepting the programmed course, the Pathway will be displayed as a series of magenta "boxes" with pointers at each corner that point in the direction of the programmed course. The Pathway boxes will not be displayed on portions of the course line that would lead the pilot to intercept the course in the wrong direction.

As the aircraft approaches the center of the programmed course and altitude, the number of Pathway boxes will decrease to a minimum of four.

Enroute

When enroute, the Pathway will be displayed along the lateral path defined by the flight plan, at the altitude selected on the G1000 altitude selector.

Flight plan changes in altitude that require a climb will be indicated by the Pathway being displayed as a level path at the altitude entered for the current flight plan leg. Because the G1000 system does not have information available to it about aircraft performance, climb profiles are not displayed by the Pathway.

If the programmed flight plan includes one or more defined VNAV descent segments, the descent path(s) will be displayed by the Pathway as prompted by the G1000 FMS.

If the flight plan includes a significant change in course at a waypoint, the Pathway boxes toward the currently active waypoint will be magenta in color. The boxes defining the next flight plan segment may be visible, but will be displayed in a white color.

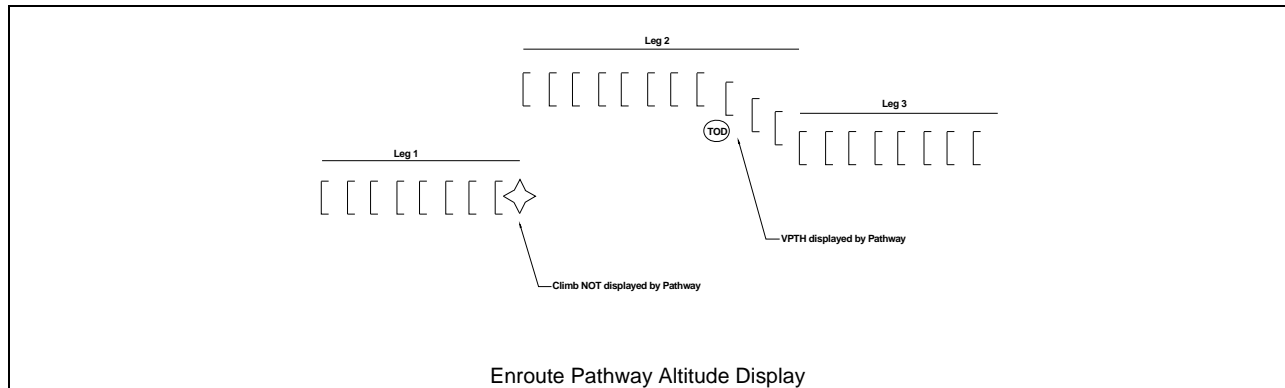

Approach

During an approach transition with the GPS CDI active, the Pathway will be displayed along the lateral path defined by the flight plan, at the altitude selected on the G1000 altitude selector. Pathway will be displayed at least up to the Final Approach Fix on all instrument approach procedures.

For ILS, LNAV/VNAV, LNAV+V and LPV approaches, the Pathway will display the lateral and vertical descent segments from the glideslope or glidepath intercept altitude, down to the Decision Altitude. For all other non-precision approaches, Pathway will not display beyond the Final Approach Fix until the missed approach segment become active.

In all cases, the pilot must still ensure that the aircraft complies with the requirements of the published instrument approach procedure.

Missed approach

When the missed approach is selected on the G1000 FMS, the Pathway to the Missed Approach Holding Point will be displayed just as described for the departure segment.

The pilot must assure that the aircraft path will, at all times, comply with the requirements of the published missed approach procedure.

If the initial missed approach leg is heading-to-altitude or a leg defined by other than a GPS course, the Pathway will not be displayed for that segment.

If the course to the Missed Approach Holding Point is out of the SVS field of view during the initial missed approach climb, the Pathway will not be visible on the PFD until the aircraft is turned toward the course.

The Pathway will be displayed at the published missed approach altitude OR the altitude set on the G1000 altitude selector WHICHEVER IS HIGHER. If the G1000 altitude selector is set to MDA on the final approach segment and not reset during the initial missed approach, the Pathway will still be displayed at the published missed approach altitude.

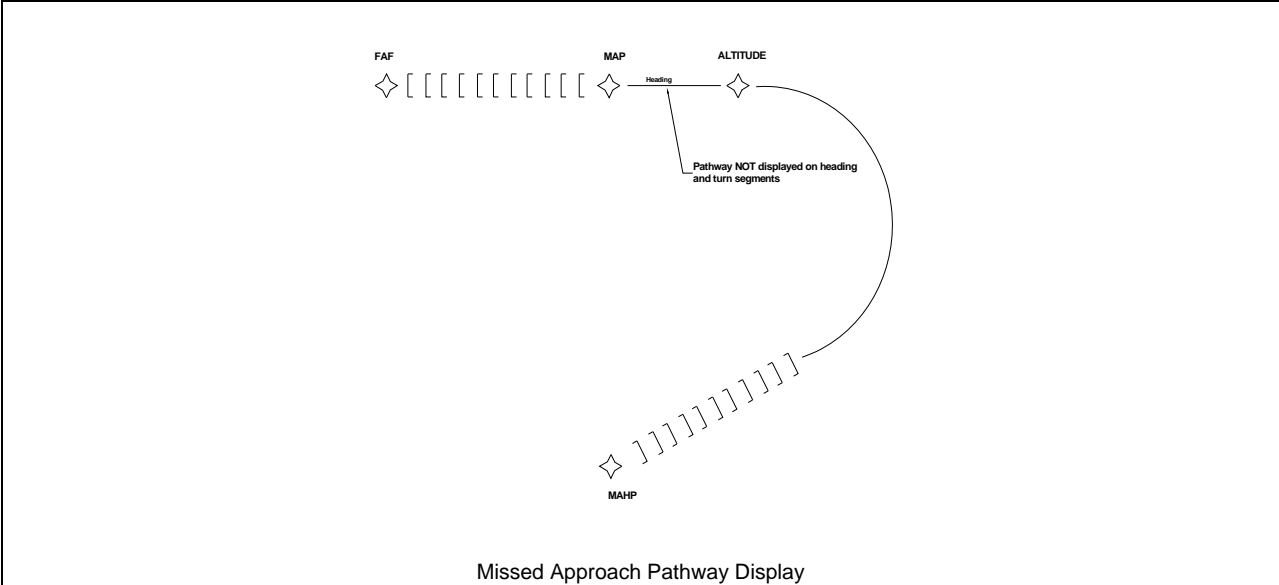

This page intentionally left blank.

Section 5 – Performance

ALTIMETER CORRECTION - NORMAL SYSTEM FLAPS UP

NOTE Above 18,000 ft, Corrected Altitude = Indicated Altitude

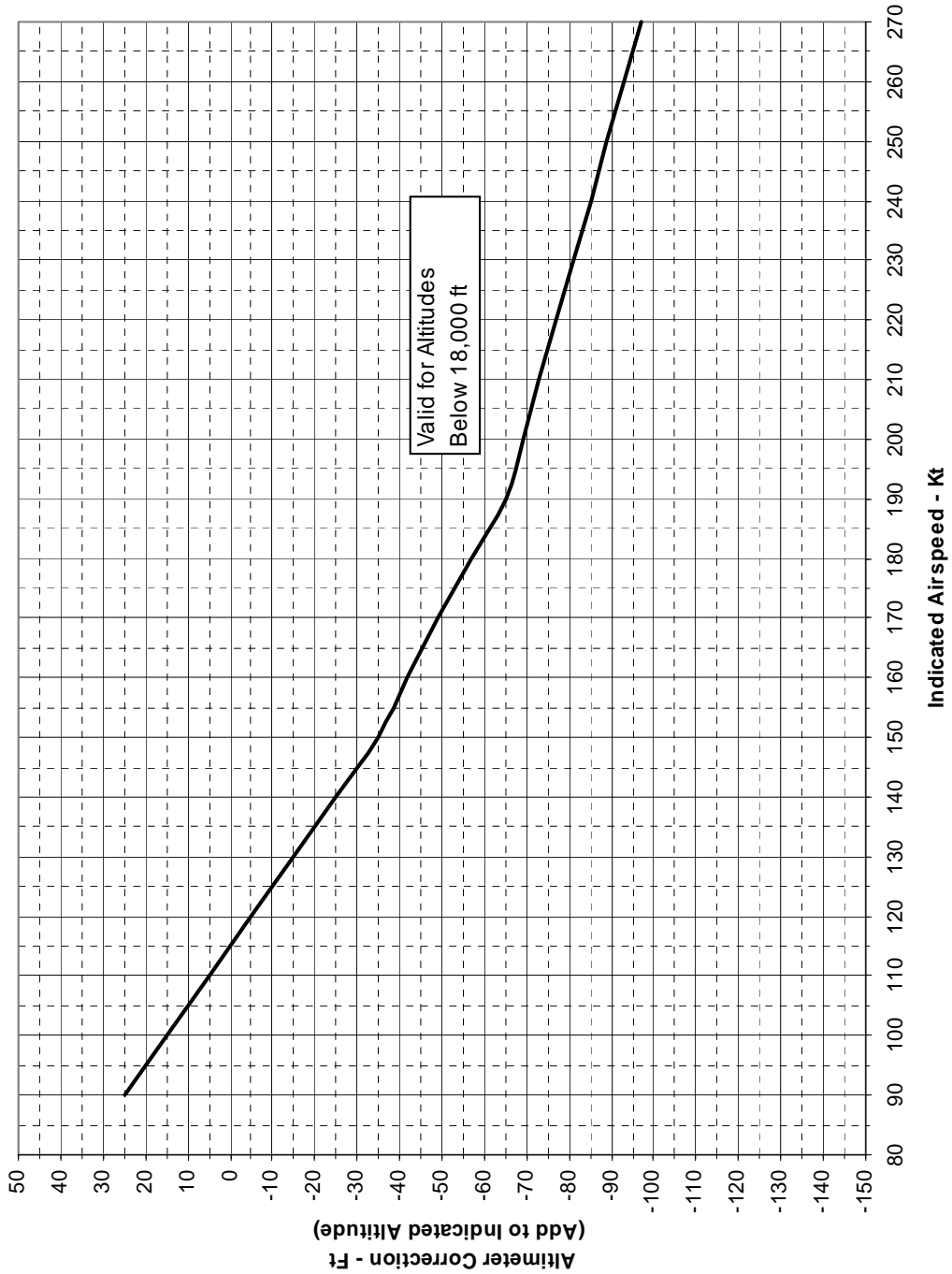

ALTIMETER CORRECTION - STANDBY ALTIMETER FLAPS UP

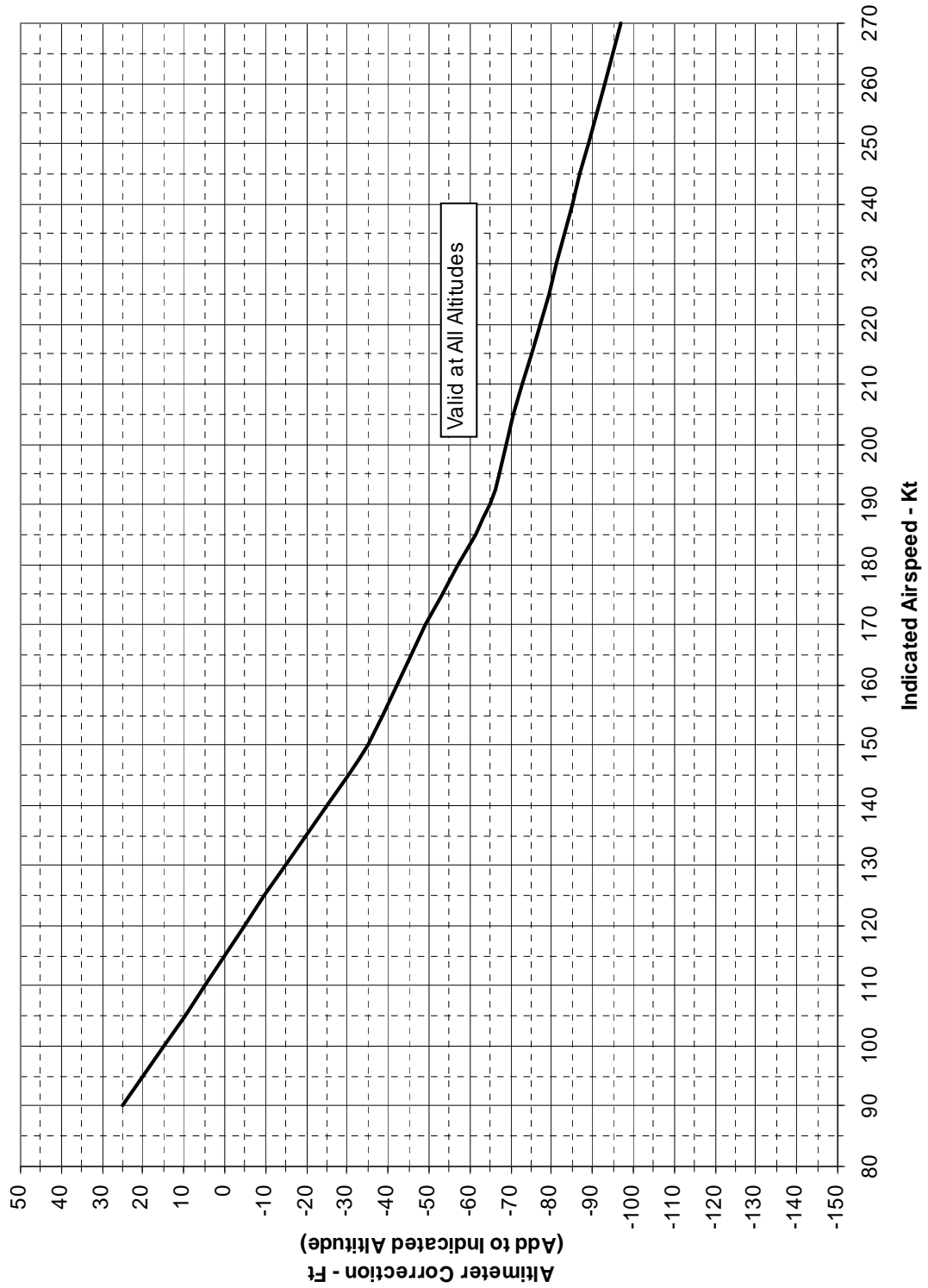

Section 6 - Weight and Balance

No Change. Refer to basic Aircraft Flight Manual or appropriate supplement.

This page intentionally left blank.

Section 7 - Systems Description

Table of Contents

| | |
|---|------------|
| GENERAL..... | 104 |
| G1000 INTEGRATED AVIONICS..... | 104 |
| SYSTEM OVERVIEW | 104 |
| INSTRUMENT PANEL..... | 104 |
| FLIGHT CONTROLS | 113 |
| AFCS, AUTOPILOT AND FLIGHT DIRECTOR | 113 |
| ELECTRIC ELEVATOR TRIM | 117 |
| ELECTRONIC STABILITY & PROTECTION (ESP) | 118 |
| FLIGHT INSTRUMENTS | 122 |
| G1000 FLIGHT INSTRUMENTS..... | 122 |
| STANDBY FLIGHT INSTRUMENTS | 122 |
| ENGINE INSTRUMENTATION..... | 123 |
| PROPELLER SYNCHROPHASER | 124 |
| ELECTRICAL SYSTEM..... | 124 |
| INVERTERS..... | 124 |
| POWER DISTRIBUTION | 124 |
| STANDBY BATTERY POWER SUPPLY | 128 |
| LIGHTING SYSTEMS..... | 129 |
| COCKPIT | 129 |
| PITOT AND STATIC SYSTEM | 129 |
| PITOT | 129 |
| STATIC..... | 130 |
| GROUND COMMUNICATIONS..... | 130 |
| SYNTHETIC VISION..... | 131 |
| TAWS AND GPWS | 135 |

GENERAL

This section supplements the Systems Description chapter in the aircraft's original Pilot's Operating Handbook and FAA Approved Airplane Flight Manual. This section will follow the format and layout of the chapter in the original manual. Only topics changed by the installation of the G1000 integrated avionics system will be addressed in this supplement.

The G1000 system is an integrated system that presents flight instrumentation, navigation, communication, weather avoidance, engine instrumentation, and supplemental flight information to the pilot for enhanced situational awareness through large-format displays. The G1000 also incorporates an automatic flight control system that includes autopilot and flight director functions, as well as an optional Electronic Stability & Protection (ESP) system. Refer to the GARMIN Pilot's Guide and Cockpit Reference Guide, P/N 190-01343-00 and 190-01344-00 Rev. A or later FAA accepted revision for detailed descriptions of the GARMIN G1000 system including its components, detailed descriptions of functions, and operating instructions.

G1000 INTEGRATED AVIONICS

SYSTEM OVERVIEW

The main components of the G1000 Integrated Avionics system consists of 14 Line Replaceable Units (LRU)s. Seven of those LRUs are mounted in the cockpit and interface the pilot to the G1000 system. There are two Primary Flight Displays (PFDs) that display primary flight information to the pilot, including attitude, airspeed, altitude, heading, vertical speed, navigation information, system information, and pilot situational awareness information. In the center of the cockpit, a 15 inch Multi-Function Display (MFD) displays engine gauges, flight plan data, various map displays, and access to aviation and weather information. Information access and data entry through the MFD is via the GCU 477 MFD controller mounted in the pedestal between the pilot and copilot seats.

Communications are interfaced through the PFDs and two audio panels mounted outside each PFD. Radio tuning controlled through both PFDs and the GCU 477 controller. Audio levels for the Com and Nav radios, ADF, intercom, and XM music are controlled by the two audio panels.

The G1000 incorporates a fully digital integrated autopilot and flight director. Pilot interface to the AFCS is through the GMC 710 Autopilot Mode controller mounted in the center of the cockpit just below the airplane's glareshield.

In addition to dual Primary Flight Displays, the system incorporates dual Air Data Computers (GDC), Dual AHRS (GRS), and Dual Integrated Avionics (GIA) units for system redundancy. Each GIA contains a VHF Com radio, a VHF Nav radio, Glide Slope receiver, Marker Beacon receiver, and a SBAS augmented GPS receiver.

Finally, the G1000 system includes weather radar and satellite downlinked weather information for weather avoidance and situational awareness.

INSTRUMENT PANEL

The G1000 Instrument Panel consists of two 10 inch LCD Primary Flight Displays, one 15 inch LCD Multi-Function Display, two audio panels, autopilot / flight director mode control panel, an MFD controller, and three 2 ¼ inch standby instruments. The ADF control head was relocated from the radio stack location on the instrument panel to the pedestal.

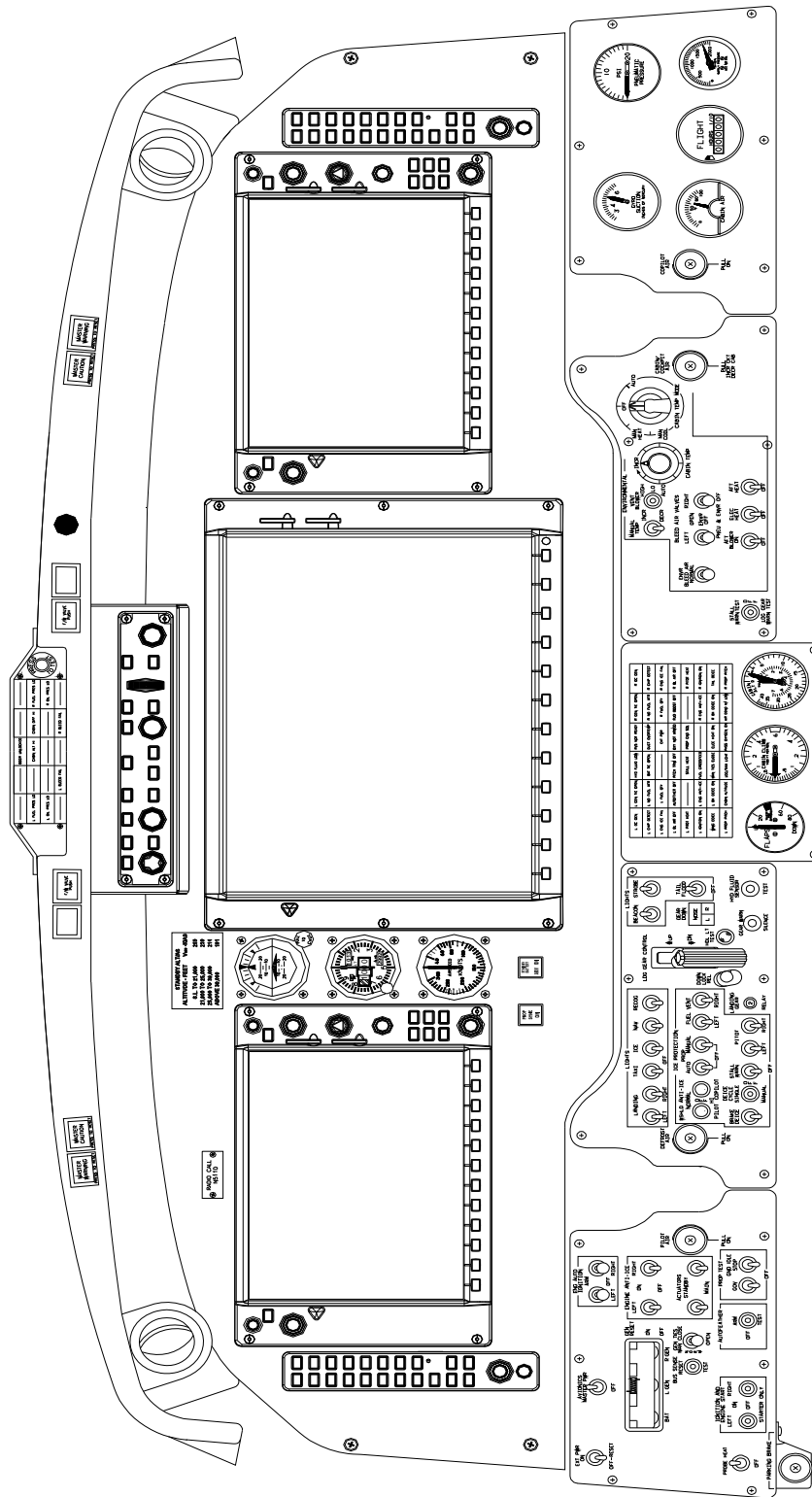

Figure 3, Instrument Panel

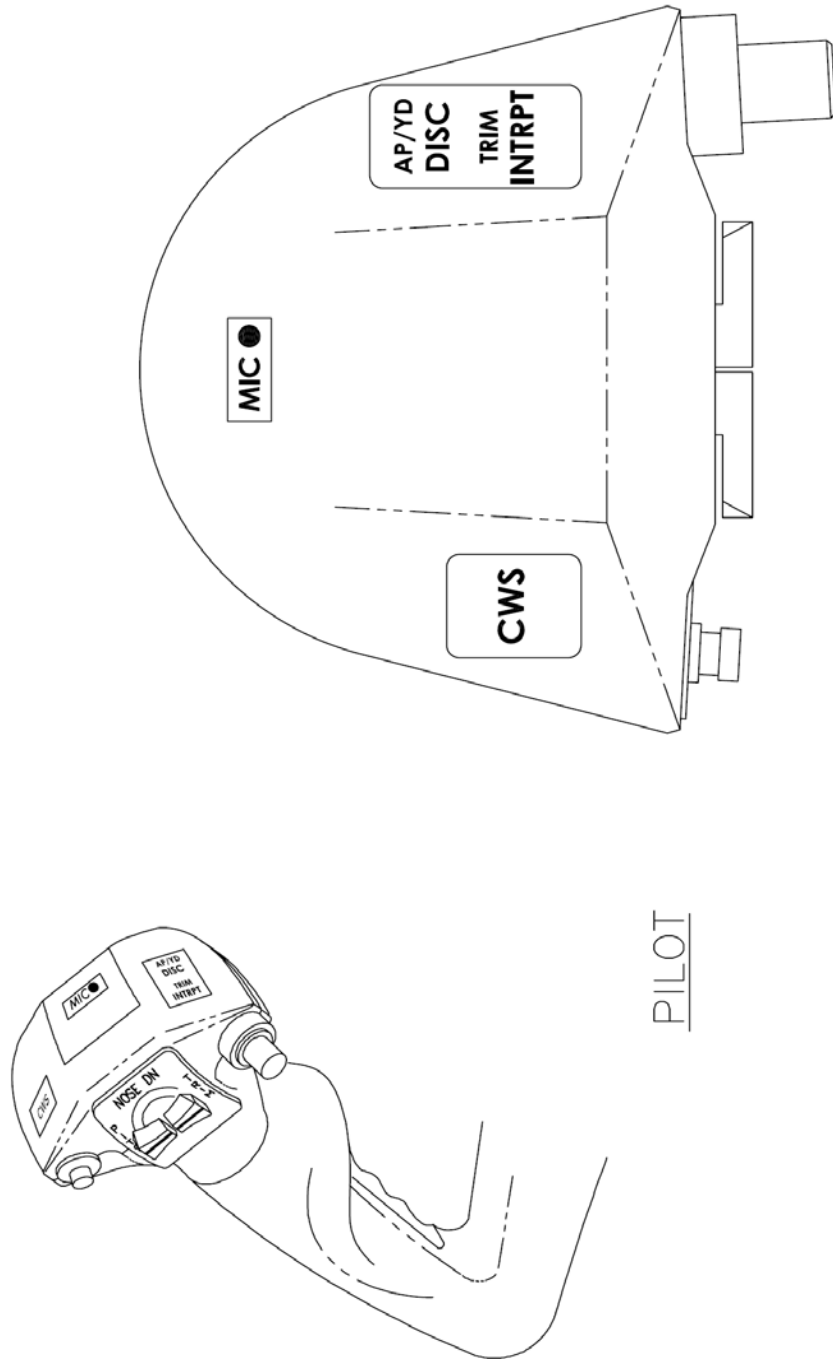
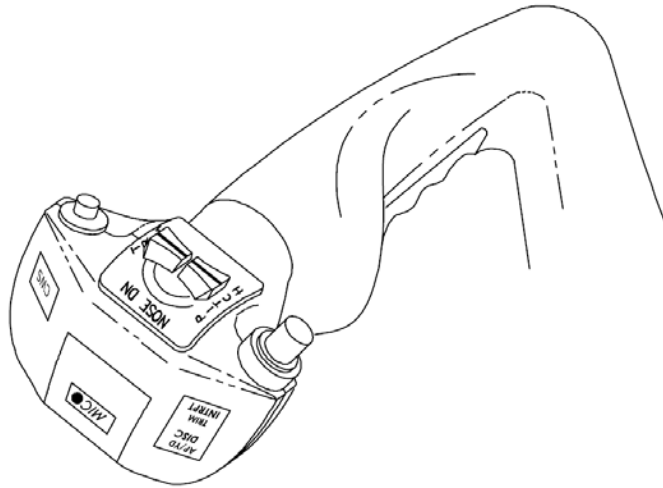

Figure 4, Pilot's Control Wheel



COPILOT

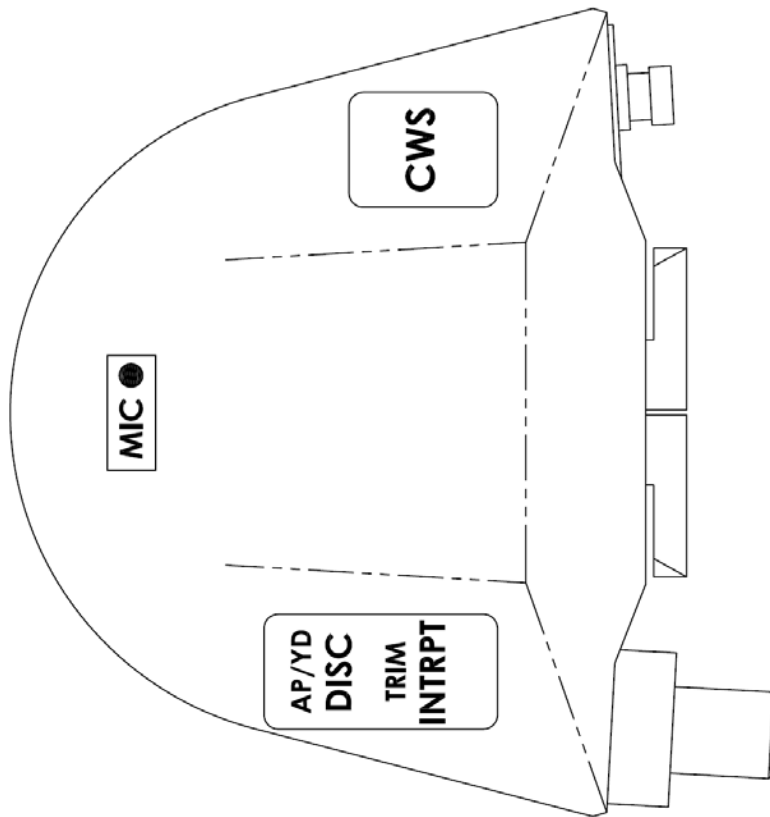
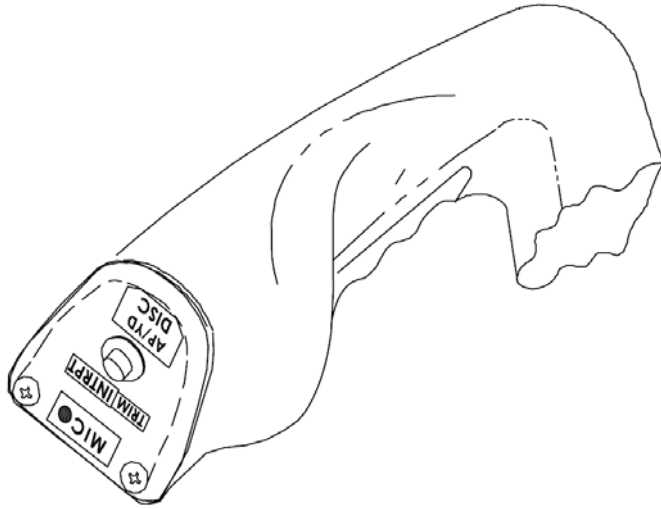

Figure 5, Copilot's Control Wheel With Trim Switches



COPILOT

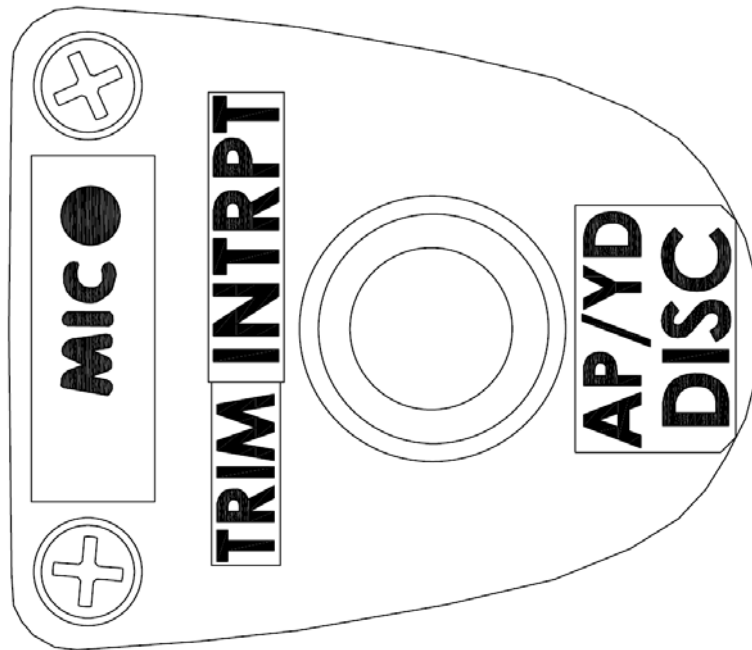

Figure 6, Copilot's Control Wheel Without Trim Switches

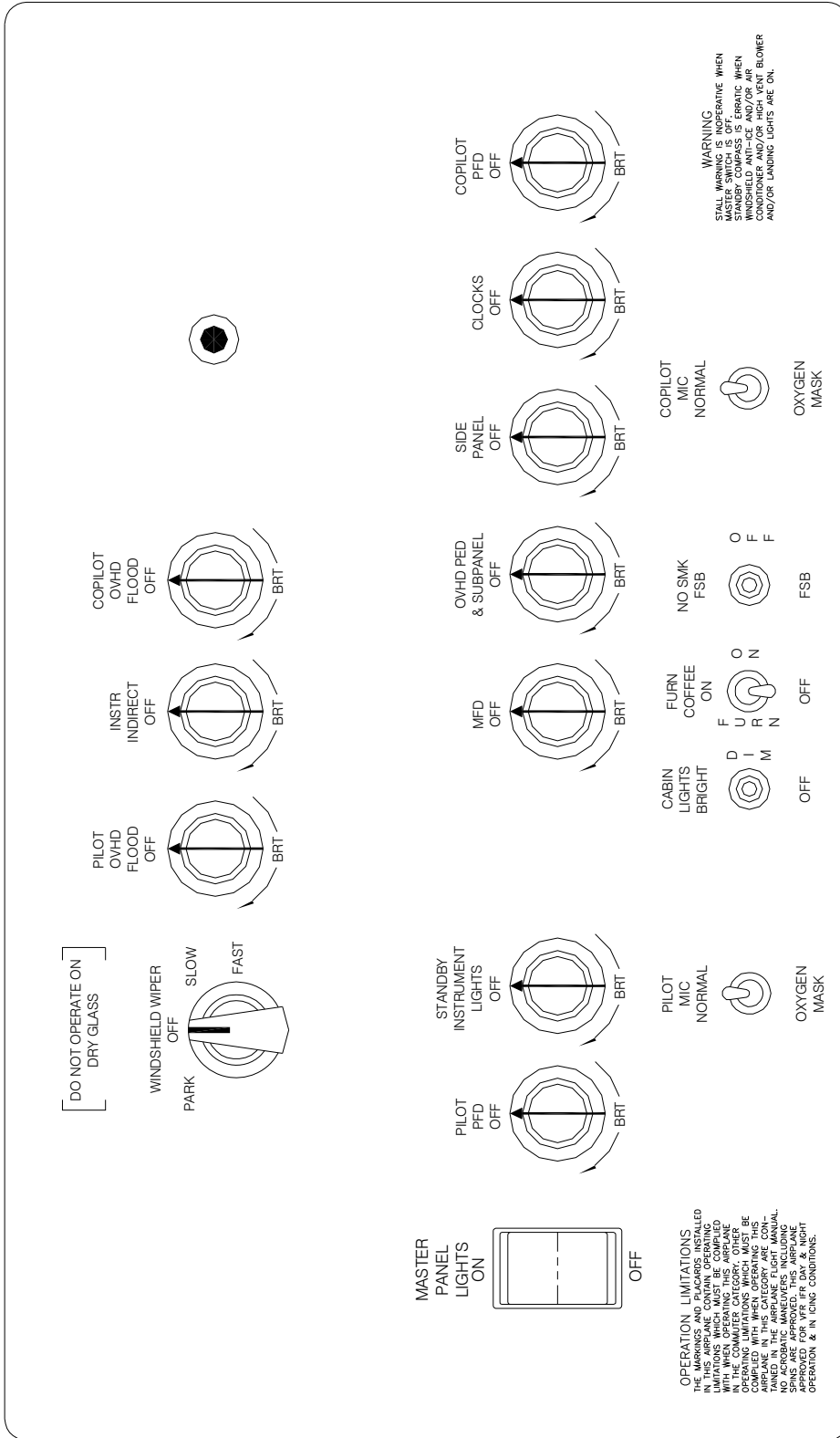

Figure 7, Overhead Panel

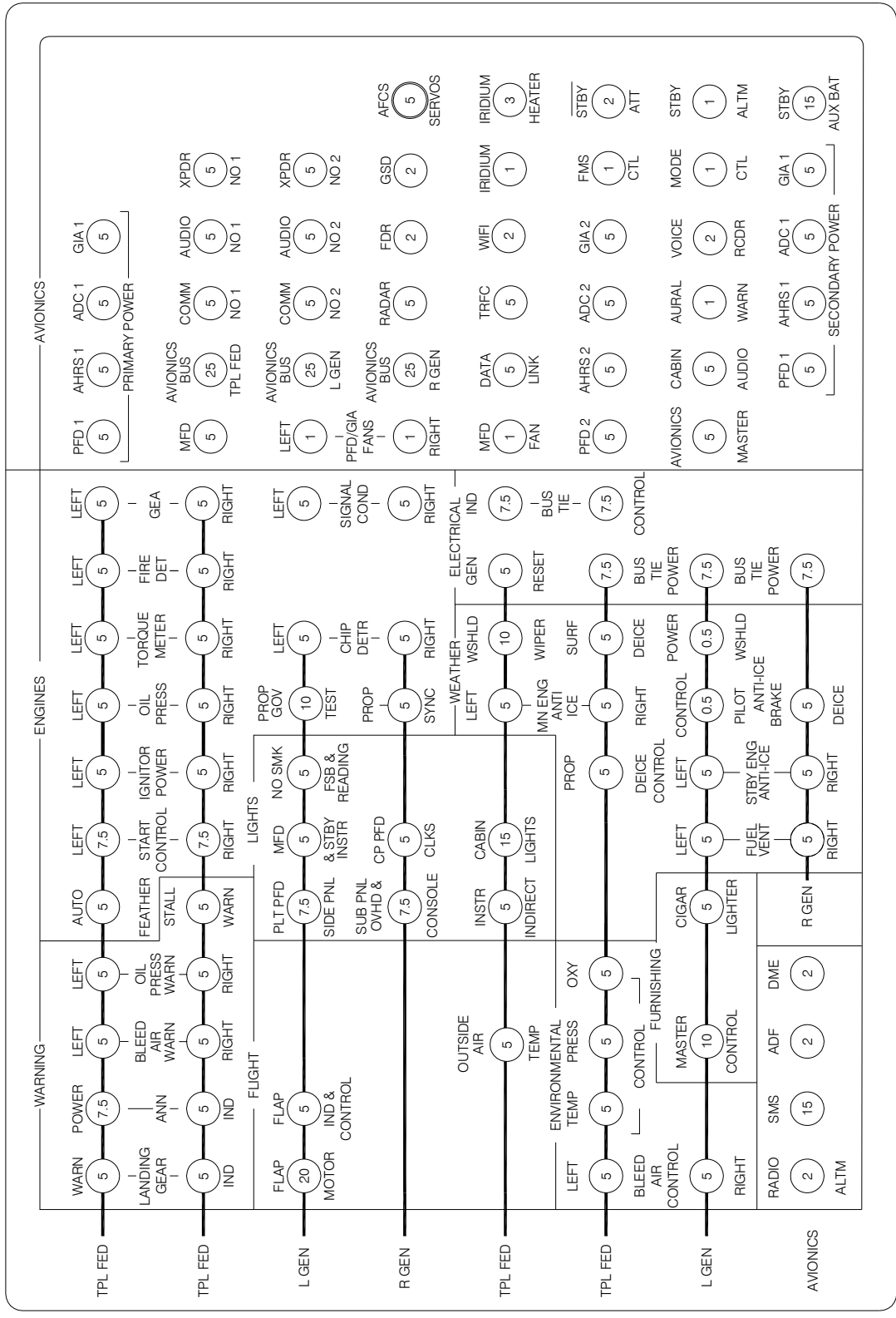

Figure 8, Right Side Circuit Breaker Panel

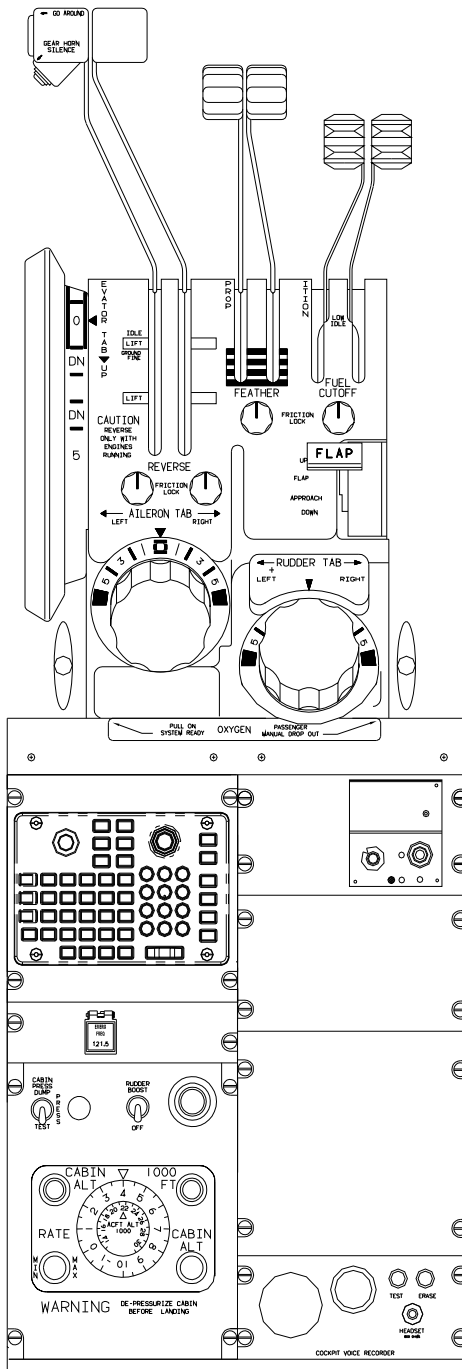

Figure 9, Pedestal Configuration

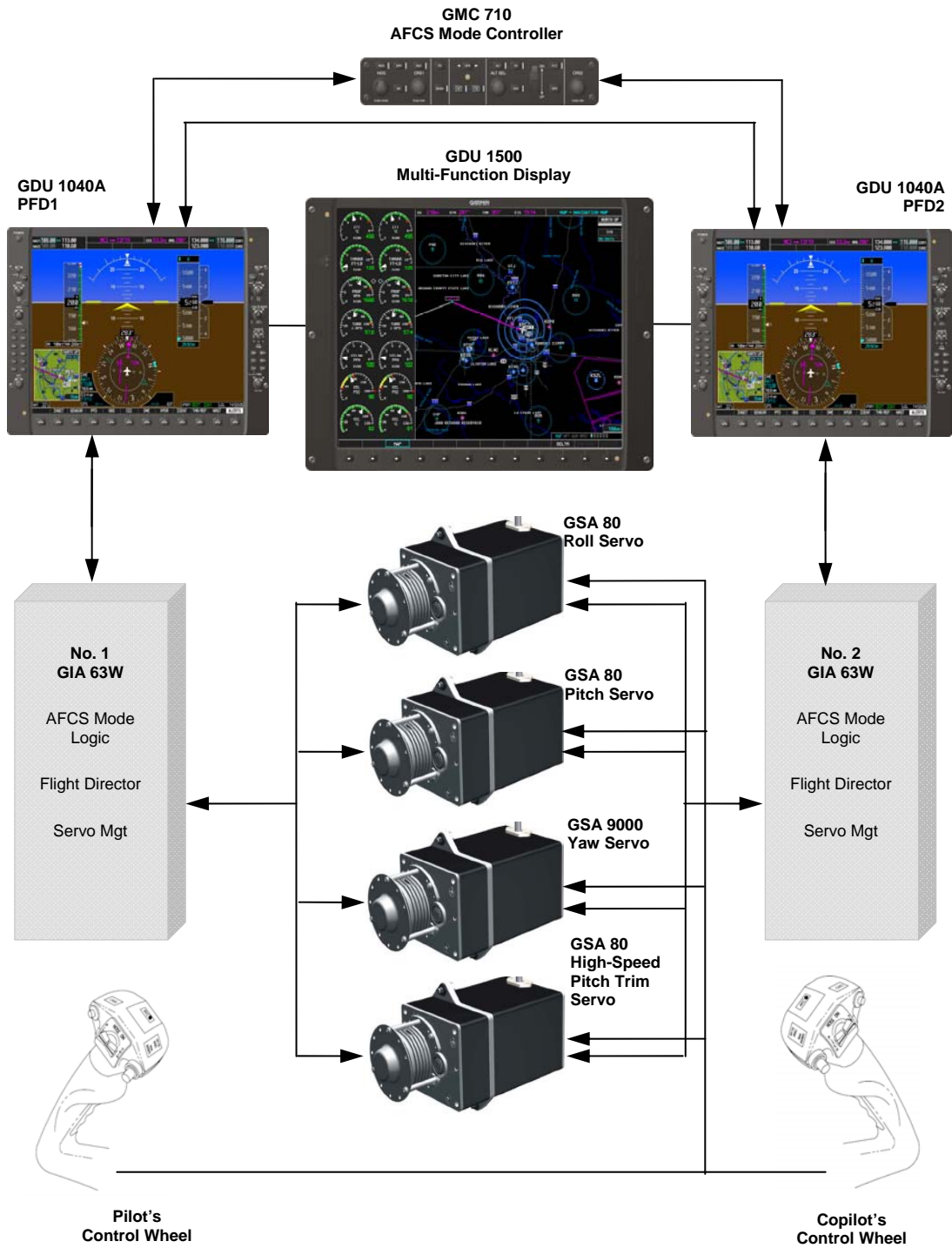

Figure 10, GFC 700 System Interface

FLIGHT CONTROLS

AFCS, AUTOPILOT, FLIGHT DIRECTOR AND RUDDER BOOST

The GFC 700 is a digital Automatic Flight Control System (AFCS), fully integrated within the G1000 System avionics architecture. The GFC 700 is a three-axis autopilot and flight director system which provides the pilot with the following features:

Autopilot (AP) — Autopilot operation occurs within the pitch, roll, and pitch trim servos. It also provides servo monitoring and automatic flight control in response to flight director steering commands, AHRS attitude and rate information, and airspeed.

Flight Director (FD) - Two flight directors, each operating independently within their respective GIA and referred to as pilot-side and copilot-side. Commands for the selected flight director are displayed on both PFDs.

The flight director provides:

- Command Bars showing pitch/roll guidance
- Vertical/lateral mode selection and processing
- Autopilot communication

Yaw Damper (YD) — The yaw servo is self-monitoring and provides Dutch Roll damping and turn coordination in response to yaw rate, roll angle, vertical acceleration, and airspeed.

Rudder Boost — The GFC 700 incorporates the rudder boost capabilities. The rudder boost is enabled by setting the pedestal mounted control switch, placarded RUDDER BOOST – OFF, to the RUDDER BOOST position. The system senses bleed air pressure from both engines. When the difference in these pressures exceeds a preset level, the yaw servo is activated and deflects the rudder to assist pilot effort in maintaining directional control. The servo contribution is proportional to the bleed air pressure differential. Trimming of the rudder must be accomplished by the pilot. The rudder boost system is disabled if the RUDDER BOOST switch is OFF, or when one of the bleed air switches is in the PNEU & ENVIR OFF position. Rudder boost is interrupted when the AP/YD DISC/TRIM INTRPT button is pressed.

An amber caution annunciator, [RUD BOOST OFF], is provided on the caution/advisory/status annunciator panel as illustrated below to indicate that the rudder boost system is unavailable due to the rudder boost control switch being in the OFF position, the AP/YD DISC/TRIM INTRPT has been pressed on either yoke, or if a fault in the rudder boost system has rendered it inoperative.

CAUTION /ADVISORY PANEL ILLUSTRATION

| | | | | | |
|--|--------------------|--|--|------------------|--|
| | | | | | |
| | | | | | |
| | | | | | |
| | **RUD BOOST OFF | | | RUD BOOST OFF | |
| | | | | | |
| | | | | | |
| | | | | | |

**FA-226 and after, or airplanes with Raytheon Aircraft Kit P/N 130-9600 installed.

Electric Pitch Trim — The pitch trim servo provides manual electric pitch trim capability when the autopilot is not engaged.

Pilot commands to the AFCS are entered through the GMC 710 Autopilot Mode Controller mounted in the center of the cockpit under the airplane's glareshield. The GMC 710 controller also controls the heading bug, navigation course selector on each PFD, and the altitude preselect.

Other components of the autopilot include four servos that also contain autopilot processor, control wheel-mounted elevator trim switches (copilot's side optional), control wheel-mounted autopilot/yaw damper disconnect and trim interrupt switch (AP/YD DISC/TRIM INTRPT), control wheel-mounted CWS (Control Wheel Steering) switch, and a Go-Around switch mounted in the left power lever knob.

The following conditions will cause the autopilot to disconnect:

- Electrical power failure, including pulling the AFCS SERVOS circuit breaker
- Electrical power failure to the GMC 710 Autopilot Mode Controller, including pulling the MODE CTL circuit breaker
- Internal autopilot system failure
- Malfunction of either AHRS (two fully functional AHRS are required for the autopilot to function)
- Failure of the on-side PFD
- Depressing the red A/P Y/D DISC/TRIM INTRPT button on the pilot's or copilot's (if installed) control wheel
- Actuating the left section of the manual electric trim split switch, pilot's and copilot's control wheel
- Pushing the AP button on the autopilot mode controller when the autopilot is engaged
- Pushing the GO AROUND button on the left power lever (non-ESP equipped airplanes)

NOTE

Pressing and holding the CWS (control wheel steering) switch on the left grip of the pilot's control wheel will disconnect the autopilot servos from the airplane flight controls as long as the CWS switch is depressed. Upon release of the CWS switch, the system will synchronize to the existing pitch and roll modes selected. Review the Cockpit Reference Guide for more information.

The following tables list the available AFCS vertical and lateral modes with their corresponding controls and annunciations. The mode reference is displayed next to the active mode annunciation for Altitude Hold, Vertical Speed, and Flight Level Change modes. The NOSE UP/DN Wheel can be used to change the vertical mode reference while operating under Pitch Hold, Vertical Speed, or Flight Level Change Mode. Increments of change and acceptable ranges of values for each of these references using the NOSE UP/DN Wheel are also listed in the table.

AFCS VERTICAL MODES

| Vertical Mode | Control | Annunciation | Reference Range | Reference Change Increment |
|--------------------------------|------------------|--------------|------------------------------|----------------------------|
| Pitch Hold | (default) | PIT | 25° Nose up 20° Nose Down | 0.5° |
| Level | *** | LVL | 0 fpm | |
| Selected Altitude Capture | * | ALTS | | |
| Altitude Hold | ALT Key | ALT nnnnn FT | | |
| Vertical Speed | VS Key | VS nnnn FPM | -4000 to +4000 fpm | 100 fpm |
| Flight Level Change, IAS Hold | FLC Key | FLC nnn KT | 100 to 263 kt | 1 kt |
| Flight Level Change, Mach Hold | | FLC M 0.nn | M 0.25 to 0.58 | M0.01 |
| Vertical Path Tracking (VNAV) | VNV Key | VPTH | | |
| VNV Target Altitude Capture | ** | ALTV | | |
| Glidepath | APR Key | GP | | |
| Glideslope | | GS | | |
| Takeoff (on ground) | GA Switch | TO | | |
| Go Around (in air) | | GA | | |

* ALTS arms automatically when PIT, VS, FLC, TO, or GA is active, and under VPTH when the Selected Altitude is to be captured instead of the VNV Target Altitude.

** ALTV arms automatically under VPTH when the VNV Target Altitude is to be captured instead of the Selected Altitude.

*** ESP equipped aircraft only. LVL mode is entered from an automatic engagement of the autopilot due to the aircraft remaining outside of the normal flight envelope for an extended amount of time.

AFCS LATERAL MODES

| Lateral Mode | Control | Annunciation | Maximum Roll Command Limit |
|--|------------------|--------------|---------------------------------|
| Roll Mode | (default) | ROL | 25° Left Bank 25° Right Bank |
| Level | ** | LVL | 0° Roll |
| Low Bank | BANK Key | * | 15° Left Bank 15° Right Bank |
| Heading Select | HDG Key | HDG | 25° Left Bank 25° Right Bank |
| Navigation, GPS Arm/Capture/Track | NAV Key | GPS | 30° Left Bank 30° Right Bank |
| Navigation, VOR Enroute Arm/Capture/Track | | VOR | 25° Left Bank 25° Right Bank |
| Navigation, LOC Arm/Capture/Track (No Glideslope) | | LOC | 25° Left Bank 25° Right Bank |
| Backcourse Arm/Capture/Track | BC Key | BC | 25° Left Bank 25° Right Bank |
| Approach, GPS Arm/Capture/Track (Glidepath Mode Automatically Armed, if available) | APR Key | GPS | 30° Left Bank 30° Right Bank |
| Approach, VOR Arm/Capture/Track | | VAPP | 25° Left Bank 25° Right Bank |
| Approach, ILS Arm/Capture/Track (Glideslope Mode Automatically Armed) | | LOC | 25° Left Bank 25° Right Bank |
| Takeoff (on ground) | GA Switch | TO | Wings Level |
| Go Around (in air) | | GA | Wings Level |

* No annunciation appears in the AFCS Status Box. The commandable bank angle range is indicated by a green band along the Roll Scale of the Attitude Indicator.

** ESP equipped aircraft only. LVL mode is entered from an automatic engagement of the autopilot due to the aircraft remaining outside of the normal flight envelope for an extended amount of time.

The CWS Button does not change lateral references for Heading Select, Navigation, Backcourse, or Approach modes. The autopilot guides the aircraft back to the Selected Heading/Course upon release of the CWS Button.

The autopilot may be engaged within the following ranges:

Pitch 50° nose up to 50° nose down

Roll ±75°

If the above pitch or roll limits are exceeded while the autopilot is engaged, the autopilot will disconnect. Engaging the autopilot outside of its command limits, but within its engagement limits, will cause the autopilot to return the aircraft within command limits. The autopilot is capable of commanding the aircraft in the following ranges:

Pitch 25° nose up to 20° nose down

Roll ±25°, or ±30° while using a GPS lateral mode

The Flight Director is not designed to perform unusual attitude recoveries from attitudes outside the following range:

Pitch 50° nose up to 50° nose down
Roll ±75°

If the above pitch or roll limits are exceeded with the flight director displayed on either PFD or the MFD, the flight director will be removed (de-cluttered) from the display until the aircraft is within display limits.

ELECTRIC ELEVATOR TRIM

Electric elevator trim is standard with the G1000 system installation. The electric elevator trim can be operated manually by the pilot using the pitch trim switches on the control wheel, or, automatically by the autopilot. Electric Elevator trim switches are optional on the copilot's control wheel. If pitch trim switches are installed on the copilot's control wheel, the pilot's pitch trim inputs override those made by the copilot

The ON/OFF toggle switch on the pedestal has been removed. Electric elevator trim will function if the AFCS SERVOS circuit breaker (right side circuit breaker panel) is set and the autopilot has satisfactorily completed a preflight test.

Pitch trim rocker switches on the pilot's control wheel manually control the electric elevator trim system. NOSE DN at the top of the rocker switch, when depressed causes the elevator pitch trim servo to move the trim tab in the upward direction resulting in the nose of the airplane pitching downward. The control column will move in the forward direction and the pitch trim wheel will move forward in the nose down direction. Depressing NOSE UP at the bottom of the rocker switch results in the opposite of the previous motions with the airplane nose pitching up.

Runaway or malfunctioning trim can be interrupted by pressing and holding the red A/P Y/D DISC TRIM INTRPT switch on either control wheel. Pulling the AFCS SERVOS circuit breaker on the right side circuit breaker panel will disable the electric elevator trim so it will not move when the TRIM INTRPT switch is released.

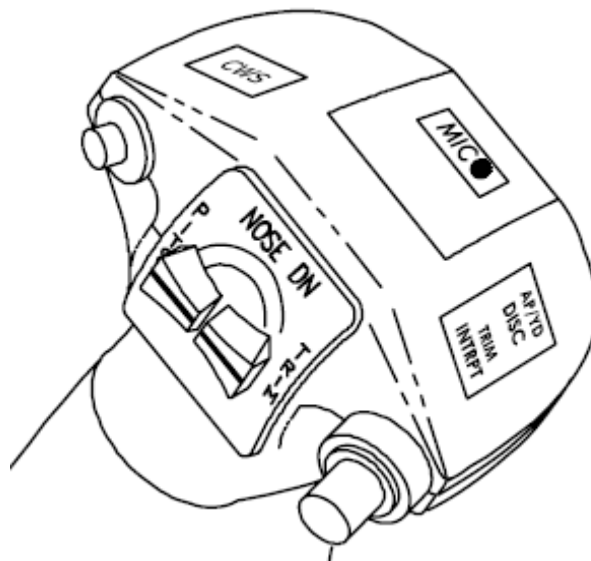

Figure 11, Electric Trim Switches, Pilot's Control Wheel

ELECTRONIC STABILITY & PROTECTION (ESP)

Electronic Stability and Protection (ESP) is an optional function on a GFC-700-equipped airplane that uses the autopilot servos to assist the pilot in maintaining the airplane in a safe flight condition within the aircraft's normal pitch, roll and airspeed envelopes. Additionally, ESP uses the aircraft's existing lift computer and stall warning system to protect against stalling the aircraft.

Electronic Stability and Protection is invoked when the pilot allows the airplane to enter one or more conditions beyond normal flight defined below:

- Pitch attitude beyond normal flight (+22°, -17°)
- Roll attitude beyond normal flight (45°)
- High airspeed beyond normal flight (Above 263 KIAS or .58M)

The conditions that are required for ESP to be available are:

- Pitch and Roll servos available
- Autopilot not engaged
- The Global Positioning System (GPS) altitude above ground (based on TAWS terrain data base) is more than 200 feet
- Aircraft is within the autopilot engagement envelope (+/-50° in pitch and +/-75° in roll)

Protection for excessive Pitch, Roll, and Airspeed is provided when the limit thresholds are first exceeded, which engages the appropriate servo in ESP mode at a nominal torque level to bring the airplane back within the normal flight envelope. If the airplane deviates further from the normal flight envelope, the servo torque will increase until the maximum torque level is reached in an attempt to return the aircraft into the normal flight envelope. Once the aircraft returns to within the normal flight envelope, ESP will deactivate the autopilot servos.

When the normal flight envelope thresholds have been exceeded for more than approximately 10 seconds, ESP Autolevel Mode is activated. Autolevel Mode engages the AFCS to bring the airplane back into straight and level flight based on 0° roll angle and 0 fpm vertical speed. An aural "ENGAGING AUTOPILOT" alert sounds and the Flight Director mode annunciation will indicate LVL for the pitch and roll modes.

Anytime an ESP mode is active, the pilot can interrupt ESP by using either the Control Wheel Steering (CWS) or Autopilot Disconnect (AP DISC) switch, or simply override ESP by overpowering the AFCS servos. The pilot may also disable ESP by accessing the Multi-Function Display (MFD) AUX – SYSTEM SETUP 2 page on the MFD and manually disabling ESP. Once the flight has ended and power is removed from the G1000 system, ESP will default to "Enabled" on the next power-up.

PFD display symbology implemented for ESP is illustrated in Figures 12 thru 14. All other indications on the GDU displayed in the examples are to provide position reference for the ESP system symbology. The values indicated are not representative of a condition required to activate ESP.

- When the GDU receives information from the GIA indicating that ESP is not armed, the GDU will not display ESP indications.
- When the GDU receives information from the GIA indicating that ESP is armed, the GDU will display the ESP roll limit indices.
- The engagement and disengagement attitude limits are displayed with double hash marks on the roll indicator depending on the aircraft attitude and whether or not ESP is active in roll. When ESP is inactive (roll attitude within nominal limits) only the engagement limit indications are displayed in order to reduce clutter on the roll indicator. See Figure 12 for an example of the ESP engagement limit indications.

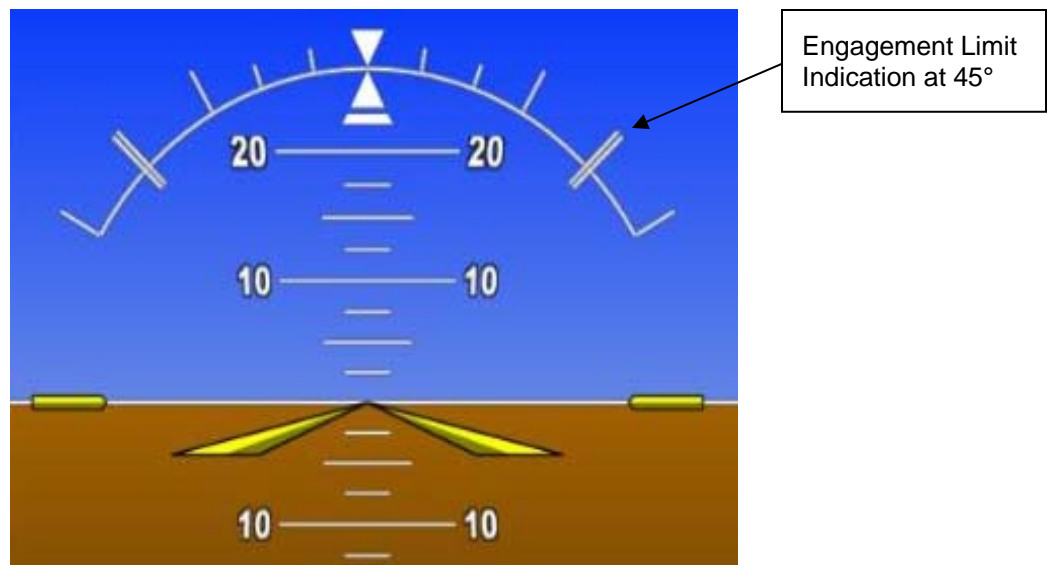

Figure 12 – Nominal Roll Attitude ESP Engagement Limit Indications

Once ESP becomes active in roll, the engagement limit indication that was crossed (either left or right) will move to the lower disengagement limit indication over a period of 1 second. The opposite roll limit remains at the engagement limit. Figure 13 shows the engagement limit indication just prior to ESP activation (left image) and just after ESP activation (right image 1 second after ESP activation).

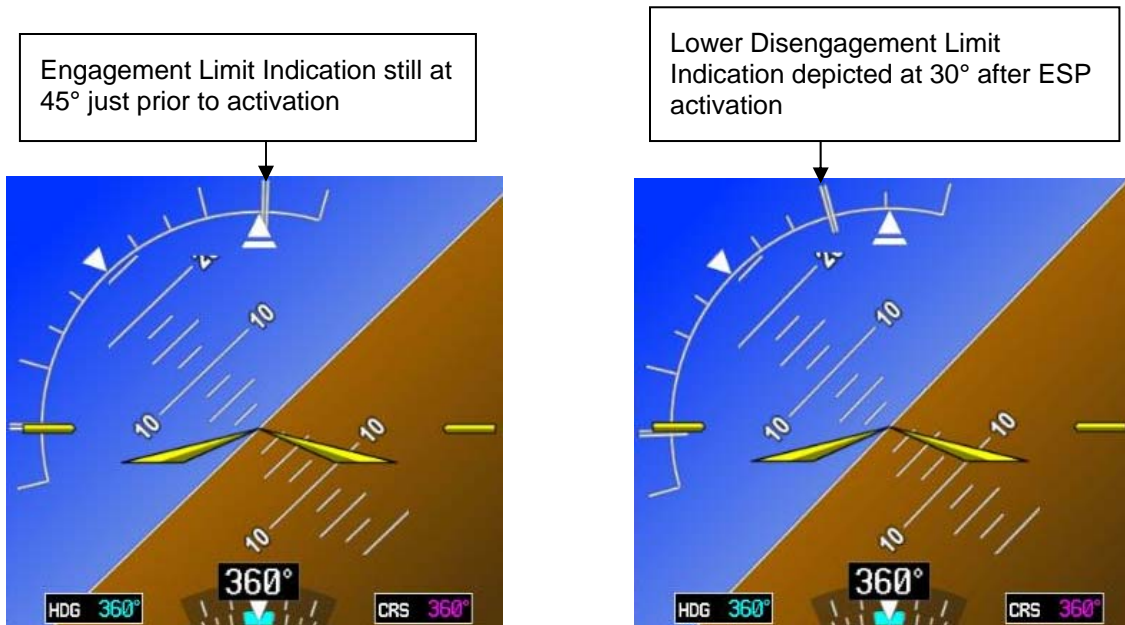

Figure 13 – Engagement Limit Indications Upon ESP Activation

If an attitude becomes extreme enough for the upper disengagement limit indication to be shown it will be drawn in a similar fashion to the engagement limit indication. See Figure 14 for an example of the ESP roll indication when ESP is active with an extreme roll attitude. In this case, the left roll limit is the engagement limit and the two right roll ESP limits are the lower and upper disengagement limit indications.

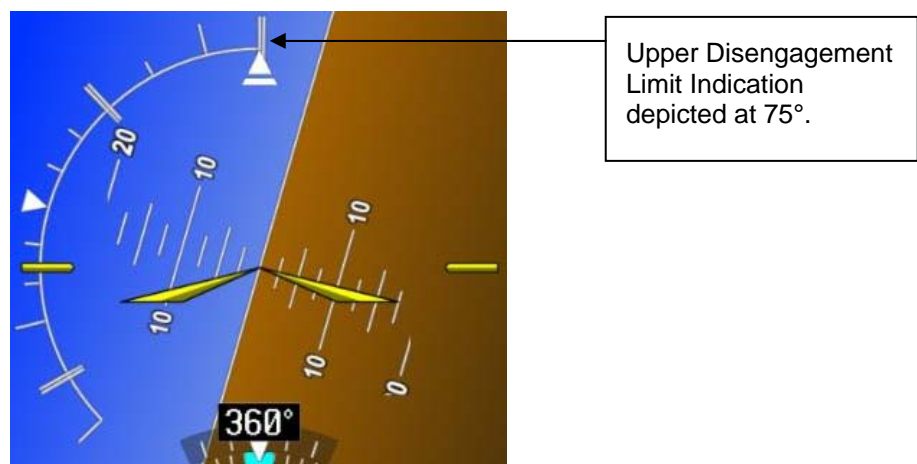

Figure 14 – Minimum and Maximum Roll Attitude ESP Disengagement Limit Indications

The ESP roll limit indications are not de-cluttered when the aircraft is in an extreme attitude. ESP roll limit indications are not shown when ESP is not configured for a given installation, ESP is not available as determined by the active GIA, or the autopilot is engaged.

Autopilot Underspeed Protection

For aircraft that have ESP installed, the AFCS is able to detect and protect against underspeed situations while the autopilot is engaged.

When the AFCS is engaged in a non-altitude critical mode (LVL, PIT, FLC, VS, VNV) and airspeed falls below the minimum threshold of 100 KIAS, the AFCS automatically enters minimum airspeed mode. A MINSPD annunciation appears above the airspeed tape, and the AFCS causes the airplane to pitch down to maintain 100 KIAS. An aural "AIRSPEED" alert will sound once when entering non-altitude critical Underspeed Protection.

If the AFCS is engaged in an altitude critical mode (ALT, GS, GP and GA) and the aural stall warning is played for more than 1 second, the AFCS will maintain a wings-level roll attitude and pitch the aircraft down at ~1kt/sec to maintain an airspeed that will cause the aural stall warning to stop playing, plus 2 KIAS. Also, an aural "AIRSPEED" alert will sound every 5 seconds.

All Underspeed Protection modes are exited automatically when there is enough aircraft performance to follow the originally selected flight director mode and reference.

Coupled Go-Around

ESP equipped aircraft are capable of flying fully coupled go-around maneuvers. Pressing the GA button on the left power lever does not disengage the autopilot. Instead, the AP will attempt to capture and track the flight director command bars. If insufficient aircraft performance is available to follow the commands, the AFCS will enter altitude-critical Underspeed Protection mode after approximately 10 seconds. GA mode is the only ESP-associated mode that can be engaged below 200' AGL GPS altitude.

FLIGHT INSTRUMENTS

G1000 FLIGHT INSTRUMENTS

Flight instruments are an integrated part of the G1000 system. For system descriptions, operating instructions, and abnormal failure indication refer to the Cockpit Reference and Pilot's Guides.

STANDBY FLIGHT INSTRUMENTS

There are three 2 ¼ inch standby instruments that are arranged vertically directly to the right of the pilot's Primary Flight Display:

- Standby attitude indicator
- Standby altimeter
- Standby airspeed indicator

The standby attitude indicator located at the top of the stack is normally powered by the Triple Fed Bus. In the event of total loss of aircraft electrical power, there is a standby battery that will power the standby attitude indicator for at least 30 minutes.

The second instrument in the stack is a standby altimeter. It is a mechanical instrument that requires no electrical power to display altitude. Electrical power is used for internal instrument lighting, and for an internal vibrator that is used to minimize indicator pointer sticking. The vibrator is normally powered from the Triple Fed Bus. In the event of total loss of normal aircraft electrical power, the vibrator and internal lighting are powered by the standby battery. The standby altimeter uses the copilot's static system for its source of static air pressure.

The bottom instrument is a mechanical airspeed indicator. It is a mechanical instrument that requires no electrical power to operate. Electrical power is used for internal lighting. In normal operation, power for standby instrument lighting comes from the Triple Fed Bus. In the event of a total loss of aircraft electrical power, the standby battery will power the instrument's internal lighting. The standby airspeed indicator uses the copilot's static system for its source of static air pressure, and the copilot's pitot system for its source of impact air pressure.

| STANDBY ALT/AS | |
|------------------|------------------------|
| ALTITUDE - FEET | V _{MO} - KIAS |
| S.L. TO 21,000 | 259 |
| 21,000 TO 25,000 | 239 |
| 25,000 TO 30,000 | 214 |
| ABOVE 30,000 | 191 |

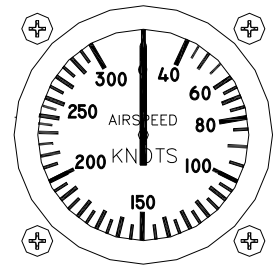
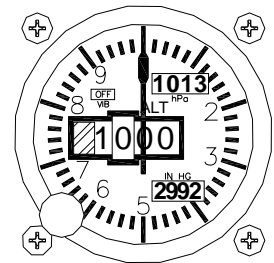
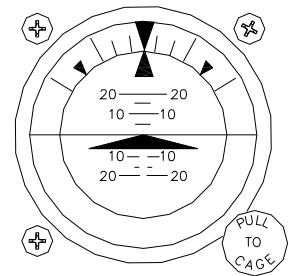

Figure 15, Standby Flight Instruments

ENGINE INSTRUMENTATION

Engine instruments, located in a window on the left side of the MFD, are grouped according to their function. The G1000 engine gauges are constructed and arranged to emulate the mechanical gauges they replaced. At the top, the ITT (Interstage Turbine Temperature) indicators and torquemeters are used to set take-off power. Climb and cruise power are established using the torquemeters and propeller tachometers while observing ITT limits. Gas generator (N_1) operation is monitored by the gas generator tachometers. The lower grouping consists of the fuel flow indicators and the oil pressure/temperature indicators.

The engine transducers send their signals to the GARMIN GEAs (Engine and Airframe LRU) which process the signals and allow the engine parameters to be displayed on the MFD. There are two GEAs; one for each engine. Operating on 28vdc power, both GEAs receive power from the Triple Fed Bus. The GEAs are protected by circuit breakers located on the left side circuit breaker panel labeled GEA.

The ITT indicator gives a reading of engine gas temperature between the compressor turbine and the power turbines. A digital indication combined with the pointer gives a resolution of 1°C .

The torquemeters give an indication in percent (%) torque being applied to the propeller. A digital indication combined with the pointer gives a resolution of 0.2%.

Propeller Autofeather annunciations are located adjacent the torquemeters, to the upper right of each indicator. When the autofeather system is armed, the green 'AFX' annunciations will be posted.

The propeller tachometer reads directly in revolutions per minute. A digital indication combined with the pointer gives a resolution of 10 rpm.

The N_1 or gas generator tachometer is in percent of rpm, based on a figure of 37,500 rpm at 100%. Maximum continuous gas generator speed is limited to 39,000 rpm or 104.0% N_1 . A digital indication combined with the pointer gives a resolution of 0.1% rpm.

The fuel flow indicators give an indication of fuel consumption in pounds of fuel per hour. A digital indication combined with the pointer gives a resolution of 1 lb/hr.

The oil pressure indicator displays oil pressure (in PSI). A digital indication combined with the pointer gives oil pressure a resolution of 1 psi.

The oil temperature indicator displays oil temperature (in Degrees Celsius). A digital indication combined with the pointer gives oil temperature a resolution of 1°C

A propeller synchroscope, located above and between the propeller tachometers, indicates propeller synchronization. When the propellers are operating at the same rpm, the display will show stationary diamond symbols. As one propeller begins to turn faster than the other propeller, the diamonds will begin to move towards the faster turning propeller and transition into an arrowhead pointing towards the faster turning propeller. The transition to a full arrowhead is complete when the propeller speed difference is equal to 50 rpm. This instrument aids the pilot in obtaining synchronization of the propellers.

PROPELLER SYNCHROPHASER

A push button ON/OFF switch is located on the instrument panel below the pilot's PFD that turns the propeller synchrophaser ON and OFF. To turn the propeller synchrophaser ON, push the PROP SYNC switch. A green ON annunciator will illuminate when the system is on. To turn the propeller synchrophaser OFF, push the PROP SYNC switch.



Refer to the Systems Description section in the airplane's original Pilot's Operating Handbook and FAA Approved Airplane Flight Manual for a description of the synchrophaser and its operation.

ELECTRICAL SYSTEM

INVERTERS

The two solid-state inverters are not needed with the G1000 system and have been removed.

POWER DISTRIBUTION

There are no changes to the electrical power generation, power feeders, control, or fault protection.

AVIONICS/ELECTRICAL EQUIPMENT BUS CONNECTION

| LEFT GENERATOR BUS (GEN No. 1) | CENTER BUS | RIGHT GENERATOR BUS (GEN No. 2) |
|-----------------------------------|-------------------------------------|------------------------------------|
| No. 2 Avionics Bus | AHRS 1 Secondary Power | No. 3 Avionics Bus |
| COM 2 | ADC 1 Secondary Power | Datalink |
| AUDIO 2 | Condenser Blower | Traffic |
| XPDR 2 | Electric Heat (Aft) | WIFI |
| RADAR | Electric Heat (Fwd) | IRIDIUM |
| DME | GIA 1 Secondary Power | IRIDIUM Heater |
| ADF | Ice Lights | Air Conditioner Clutch |
| Radio Altimeter | Landing Gear Motor | Blower, Aft Evaporator |
| WX-500 Stormscope (OPT) | Navigation Lights | Brake Deice (OPT) |
| Beacon Lights | PFD 1 Secondary Power | Bus Tie Power, R Gen |
| Bleed Air Control, R | Prop Deice Power (Manual), L & R | Bus Tie Control |
| Blower, Vent | Taxi Lights | Bus Tie Indicator |
| Bus Tie Power, L Gen | | Chip Detector, R |
| Chip Detector, L | | Copilot PFD & Clock Lights |
| Cigar Lighter | | Engine Anti-Ice, R Standby |
| Engine Anti-Ice, L Standby | | Firewall Shutoff Valve, R |
| Firewall Shutoff Valve, L | | Fuel Crossfeed |
| Flap Indicator & Control | | Fuel Pressure Warning, R |
| Flap Motor | | Fuel Qty, R |

**LEFT GENERATOR BUS
(GEN No. 1)****CENTER BUS****RIGHT GENERATOR BUS
(GEN No. 2)**Flight Inst (Pilot) & Side Panel
Lights

Fuel Pressure Warning, L

Fuel Qty, L

Fuel Qty Warning, L

Fuel Qty Warning & Transfer, Aux
L

Fuel Vent Heat, L

Furnishings Master Control

Landing Light, L

MFD Standby Lights

No Smoking, FSB & Reading
Lights

Prop Deice, Auto

PROP GOV TEST (FA-2 thru
FA-110)

Refreshment Bar, L

Signal Conditioner, L

Tail Flood Lights

Windshield Anti-Ice Control, Pilots

Windshield Anti-Ice Power, Pilots

Fuel Qty Warning, R

Fuel Qty Warning & Transfer, Aux R

Fuel Vent Heat, R

Landing Light, R

Pitot Heat, R

Prop Sync (OPT)

PROP GOV TEST (FA-111 & AFT)

Reading Lights

Recognition Lights

Refreshment Bar, R

Signal Conditioner, R

Stall Warning Heat

Strobe Lights

Sub Panel, Overhead, Console
Lights

Toilet

Window Defog

Windshield Anti-Ice, Copilot

TRIPLE FED BUS**HOT BATTERY BUS****STANDBY BATTERY**Avionics No. 1 Bus
XPDR 1

ADC 1 Primary Power

ADC 2

AFCS Servos

AHRS 1 Primary Power

AHRS 2

Annunciator Indicator

Annunciator Power

Audio 1

Aural Warning

Autofeather

Avionics Master

Bleed Air Control, L

Bleed Air Warning, L & R

Battery Relay

Battery Bus Tie

Voltmeter

Cabin Entry Lights

Door Lock Lights

Engine Fire Extinguisher,
L & R

Compass Light

Instrument Indirect Lights

Standby Altimeter Vibrator

Standby Attitude

Standby Battery Indicator

Standby Instrument Backlighting

TRIPLE FED BUS

Bus Tie Power, TPL FED
Cabin Audio
Cabin Lights
Cabin Pressurization Control
Cabin Temperature Control
COM 1
Eng Anti-Ice, L & R Main
Fan – PFD/GIA, L & R
Fire Detection L & R
Firewall Valve L & R (Alternate)
FMS Control
GEA, L & R
GIA 1 Primary Power
GIA 2
GSD
Ignitor Power L & R
Instrument Indirect Lights
Landing Gear Control
Landing Gear Indication
Landing Gear Relay
Landing Gear Warning
MFD
MFD Fan
Mode Control
Oil Pressure, L & R
Oil Pressure Warning, L & R
Outside Air Temperature (OAT)
Oxygen Control
PFD 1 Primary Power
PFD 2
Pitot Heat, L
Prop Deice Control, Manual
Signal Conditioner, L & R
Start Control, L & R
Stall Warning
Standby Pump L & R
Standby Attitude
Standby Altimeter Vibrator
Standby Auxiliary Battery

TRIPLE FED BUS

Surface Deice

Torquemeter, L & R

Voice Recorder

Windshield Wiper

STANDBY BATTERY POWER SUPPLY

The G1000 installation incorporates a 24 vdc, 5 Ah L-3 Avionics model PS-835 Standby Battery that provides electrical power for the standby attitude gyro, standby altimeter vibrator, and internal lighting for the three standby instruments and magnetic compass for a minimum of 30 minutes following a total loss of aircraft power including the aircraft's battery.

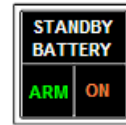

A push button switch located directly below the standby airspeed indicator controls the standby battery power system. The switch is a push ON (switch latches in), push OFF (switch pops out) type of switch.

The system has three modes: OFF, ON, and ARM.

OFF The system is OFF when the Standby Battery switch is not depressed. There are no internal switch annunciators illuminated in the switch when the system is OFF.

ON (Amber) Illuminates when the standby battery is powering the standby instruments. The Standby Battery switch must be latched 'IN' and the airplane has no source of normal electrical power for the standby battery to power the standby instruments. When the ON annunciator is illuminated, the standby battery will provide electrical power for the three standby instruments for at least 30 minutes.

ARM (Green) The system is armed for automatic operation when the Standby Battery switch is latched 'IN' and the airplane is being powered by a normal source of electrical power. Normal power sources include the airplane's battery, at least one generator, or external power.

During normal operations, the standby battery remains in a fully charged state by its own trickle charger, which is powered from the electrical system through the STBY AUX BAT circuit breaker located on the right side circuit breaker panel.

LIGHTING SYSTEMS

COCKPIT

An overhead light control panel, accessible to both pilots, incorporates a functional arrangement of all lighting systems. Each light group has its own rheostat switch placarded BRT – OFF. The MASTER PANEL LIGHTS – ON – OFF switch is the master switch for: PILOT PFD, STANDBY INSTRUMENT LIGHTS, MFD, OVERHEAD PED & SUBPANEL LIGHTS, SIDE PANEL, CLOCKS, and COPILOT PFD.

PILOT PFD – Controls the brightness of the pilot's PFD.

STANDBY INSTRUMENT LIGHTS - Controls the brightness of the internal lighting for the standby attitude indicator, standby altimeter, and standby airspeed indicator.

MFD – Controls the brightness of the Multi-Function Display (MFD).

OVERHEAD PED & SUBPANEL LIGHTS - Controls the brightness of the backlighting of the overhead light control panel and internal lighting of the overhead electrical gauges, throttle quadrant backlighting, internal lighting for pedestal-mounted gauges, and the MFD Controller panel backlighting, and the subpanel backlighting.

SIDE PANEL - Controls the brightness of the backlighting of the right side circuit breaker panel, the left side circuit breaker panel and the fuel gauge panel.

CLOCKS – Controls the brightness of the clocks mounted in the pilot's and copilot's control wheels.

COPILOT PFD – Controls the brightness of the copilot's PFD.

Separate rheostat switches individually control the instrument indirect lights in the glareshield and overhead map lights.

PITOT AND STATIC SYSTEM

PITOT

The pitot heads are the sources of impact air for the operation of the flight instruments.

A heated pitot mast is located on each side of the lower portion of the nose. Tubing from the left pitot mast is connected to the pilot's Air Data Computer (ADC1), and tubing from the right pitot mast is connected to the copilot's Air Data Computer (ADC2) and the standby airspeed indicator. The switch for the PITOT – LEFT – RIGHT – OFF is located in the ICE PROTECTION group on the pilot's right subpanel.

STATIC

The normal static system has two separate sources of static air. One source is connected to the pilot's Air Data Computer (ADC1), and the other is connected to the copilot's Air Data Computer (ADC2) and the standby instruments. Each of the normal static air lines opens to the atmosphere through two static air ports—one on each side of the aft fuselage, four ports total.

An alternate static air line is also provided for the pilot's Air Data Computer (ADC1). In the event of a failure of the pilot's normal static air source (e.g., if ice accumulations should obstruct the static air ports), the alternate source can be selected by lifting the spring-clip retainer off the PILOT'S EMERGENCY STATIC AIR SOURCE valve handle, located on the right side panel, and moving the handle aft to the ALTERNATE position. This will connect the alternate static air line to the pilot's Air Data Computer (ADC1). The alternate line is open to the unpressurized area just aft of the rear pressure bulkhead. When the alternate static air source is not needed, ensure that PILOT'S EMERGENCY STATIC AIR SOURCE valve handle is held in the forward (NORMAL) position by the spring-clip retainer.

WARNING

THE PILOT'S AIRSPEED AND ALTIMETER INDICATIONS CHANGE WHEN THE ALTERNATE STATIC AIR SOURCE IS IN USE. REFER TO THE AIRSPEED CALIBRATION – ALTERNATE SYSTEM, AND THE ALTIMETER CORRECTION – ALTERNATE SYSTEM GRAPHS IN SECTION 5, PERFORMANCE, OF THE AIRPLANE'S ORIGINAL PILOT'S OPERATION HANDBOOK AND FAA APPROVED AIRPLANE FLIGHT MANUAL FOR OPERATION WHEN THE ALTERNATE STATIC AIR SOURCE IS IN USE.

There are three drain petcocks for draining the static air lines located below the side panel on the right sidewall behind an access cover. These drain petcocks should be opened to release any trapped moisture at each inspection interval or after exposure to visible moisture on the ground, and must be closed after draining.

For RVSM compliant aircraft that operate in RVSM airspace, special care must be taken when inspecting the static ports and surrounding regions during preflight inspection. The static port openings should be smooth and round, and free of foreign material. The fuselage skin in the RVSM critical region, which is defined by markings in the vicinity of the static ports, should have no skin defects, physical damage, or large gaps and steps in the skin surface caused by improperly seated access panels or hatches.

GROUND COMMUNICATIONS

Ground communication is provided by the G1000 system by turning ON the airplane's battery. COM 1 and the pilot's audio panel will be powered. The pilot may use the airplane's speaker and hand microphone or a headset for communication.

The Terrain/Obstacle/Airport databases have an area of coverage as detailed below:

- The Terrain Database has an area of coverage from North 75° Latitude to South 60° Latitude in all longitudes.
- The Airport Terrain Database has an area of coverage that includes the United States, Canada, Mexico, Latin America, and South America.
- The Obstacle Database has an area of coverage that includes the United States.

NOTE

The area of coverage may be modified, as additional terrain data sources become available.

Obstacle and Terrain Alerts and Warnings

Obstacles and terrain displayed on the SVS system may be highlighted if an alert or warning is generated by the G1000 Terrain or TAWS system. If an obstacle alert is presented for an obstacle that is in the SVS field of view, the obstacle symbol on the PFD will turn yellow in color. If an obstacle warning is generated by the G1000 system, the obstacle symbol on the PFD will turn red.

If the G1000 Terrain or TAWS system generates a terrain alert or warning, the terrain feature displayed on the PFD will be colored yellow for an alert or red for a warning for as long as the alert remains valid.

Because the area monitored by the Terrain or TAWS system can be wider than the field of view that can be displayed by the SVS system, it is possible to receive an obstacle or terrain audible alert for an obstacle or terrain that is not shown on the SVS display. In those cases, the object generating the alert will be left or right of the aircraft. Refer to the other displays in the aircraft to determine the cause of the message.



Flight Path Marker

The SVS display includes a green circular barbed symbol called the Flight Path Marker (FPM) that represents the current path of the airplane relative to the terrain display. The FPM is always displayed when synthetic terrain is displayed and the aircraft ground speed exceeds 30 kt. The FPM indicates the current lateral and vertical path of the airplane as determined by the GPS sensor. If the FPM is above the horizon line, the airplane is climbing, and similarly if the FPM is below the horizon line, the airplane is descending. If the airplane is flying in a crosswind, the FPM will be offset from the center of the display. In that case, the center of the PFD airplane reference symbol indicates the airplane heading and the FPM indicates the direction that the airplane is actually moving, taking into account the crosswind.

The FPM indicates the current path of the airplane but does not predict the future path. If aircraft attitude, power setting, airspeed, crosswind, etc. are changed, the FPM will move to indicate the new path resulting from those changes.

If the FPM is below the terrain or obstacle displayed behind it on the PFD, the current aircraft path will not clear that terrain or obstacle. If the FPM is above that terrain or obstacle, the aircraft will clear the terrain or obstacle IF, AND ONLY IF, THE CURRENT AIRCRAFT CONFIGURATION IS MAINTAINED, AND THE AIRCRAFT PERFORMANCE WILL PERMIT YOU TO MAINTAIN THE CURRENT VERTICAL (CLIMB) GRADIENT UNTIL PAST THE TERRAIN OR OBSTACLE.



Pathway

If PATHWAY is enabled on the SVS menu of the PFD and a defined navigation path has been entered on the G1000, the SVS system will display a pathway, sometimes called a “highway in the sky” or HITS. The pathway is a perspective representation of the programmed flight path. When the aircraft is well off course, the pathway will be displayed as a number boxes floating in the sky along the programmed lateral and vertical path. As the aircraft intercepts the programmed flight path, the number of boxes displayed will be reduced to a maximum of four to avoid cluttering the PFD display. The pathway is only displayed for navigation paths that are fully defined by the sensor in use. Because a fully defined lateral and vertical path through space is not defined by them, a Pathway is not displayed for heading legs, VOR, LOC, BC or ADF segments. When the Pathway is displayed, the color of the boxes indicates the sensor generating the path. If the GPS sensor is in use, the boxes will be magenta colored. If the LOC sensor is defining the path in use, the boxes will be green.

The Pathway boxes are +/- 100 ft in vertical dimension and approximately +/-380 ft horizontally from the center of the box. The Pathway presentation is intended only to aid the pilot in awareness of the programmed flight path location relative to the airplane’s current position. The pathway is not intended for use as a primary reference in tracking the navigation path.

If a GPS based descent profile has been programmed either on the G1000 flight plan page or as part of an approach or STAR, the descent will be displayed by the Pathway. Climb paths are never displayed by the Pathway. If a profile requires a climb, the Pathway will be displayed as a level segment at the higher of the altitude defined by the programmed path or the G1000 altitude selector.



Traffic

If traffic that is within the SVS field of view is detected by the G1000 system, a symbol will be displayed on the PFD indicating the direction and relative altitude of the traffic. The traffic will be displayed as a white diamond unless it generates a traffic alert. Traffic that causes an alert will be displayed as a solid yellow circle accompanied by a yellow TRAFFIC annunciator to the right of top of the airspeed display tape.



Horizon line

The SVS display includes an always visible white horizon line that represents the true horizon. Terrain will be presented behind the horizon line, and terrain shown above the horizon line is above the current aircraft altitude. Terrain that is shown below the horizon line is below the aircraft altitude.



Horizon Heading

A heading scale may be displayed on the PFD horizon line, if selected by the pilot. The heading marks are spaced in even 30 degree increments and are presented just above the horizon line with tic marks that intersect the horizon line. The horizon heading will correspond to that presented by the HSI.

Because the horizon heading is only displayed in 30 degree increments, it should only be used for general heading awareness and not be used to establish the aircraft heading.



Airport Signs and runway highlight

If APTSIGNS is selected, a “sign post” along with a representation of the runways will be plotted on the SVS display for nearby airports that are contained in the G1000 airport database. The signpost will become visible when you are within approximately 15nm of the airport. The text identifier for the airport will be displayed inside the airport sign when the aircraft reaches approximately 8 nm from the airport. Once the aircraft reaches approximately 4.5 nm from the airport, the airport sign will be removed but the runways presentation will remain. If an approach to a specific runway has been loaded and activated, that runway will be highlighted on the SVS display.

When on an approach, the highlight for the approach runway will be considerably larger than “normal” to assist in visually acquiring the runway. The oversized highlight will automatically shrink around the runway depiction so that the runway is proportionally displayed when the aircraft is within approximately ½ nm of the threshold. Runway highlighting is displayed even if APTSIGNS are turned off.

TAWS AND GPWS

Refer to the GARMIN Pilot's Guide and Cockpit Reference Guide, P/N 190-01343-001 and 190-01344-00 Rev. A or later FAA accepted revision for complete detailed descriptions of the GARMIN G1000 TAWS and GPWS system functions and operating instructions.



Most of the G1000 Class A TAWS and GPWS functions depend upon either GPS or radar (radio) altitude to function properly. The Altitude Voice Callout (VCO) GPWS function is one of the few that may use both altitudes for normal operation. Because of the unique functional nature of the VCO function, its description is contained in this section.

VCO Description

The advisory aural Voice Callouts (VCO) are part of the TAWS GPWS functionality. In Class A TAWS configurations, aural altitude callouts "Five Hundred," "Four Hundred," "Three Hundred," "Two Hundred," and "One Hundred" are generated based on inputs from the radar altimeter and GPS altitude. When the aircraft is more than 5 NM from an airport, the VCO messages are triggered solely on radar altitude and will not function if radar altitude is unavailable.

Inside of 5 NM to an airport, the callouts are based on the aircraft's GPS altitude above the runway threshold as obtained from the G1000 aviation database. Loss of GPS altitude will cause TAWS to become unavailable. If TAWS is not available, and radar altitude is available, VCO messages will be derived strictly from radar altitude. If TAWS and radar altitude are both unavailable, VCO is inoperative.

In Class B TAWS configurations, VCO issues the "Five Hundred" aural message only. The messages are based only on GPS altitude, even if the aircraft has an operable radar altimeter. VCO messages are not available when the system status annunciations shown below are posted.

| System Status Type | Visual Annunciation | Aural Annunciation |
|------------------------------|---|-----------------------|
| TAWS System Test in Progress |  | None |
| TAWS System Failure |  | "TAWS System Failure" |
| TAWS Not Available |  | "TAWS Not Available" |

VCO callouts are inactive at the initialization of the TAWS-A or TAWS-B system. When the aircraft's height above terrain exceeds 675 feet, the function becomes enabled and is provided during all flight phases. Alerts are issued, one time only, when the height above terrain becomes less than 500 feet down to 100 feet (TAWS-A), at which time the VCO is disabled until the aircraft climbs at least 175 above the altitude associated with the last VCO callout that was issued. VCO alerts cannot be inhibited in any TAWS configuration.

This page intentionally left blank.

Section 8 – Handling, Service, and Maintenance

Refer to the G1000/GFC 700 System Maintenance Manual (contains Instructions for Continued Airworthiness) P/N 190-00716-01 Rev. 1 or later FAA approved revision for maintenance requirements for the G1000 system and components.