



GasSecure GS01 and GS01-EA  
Wireless Infrared Hydrocarbon  
Gas Detector  
**User Manual**

(For firmware version  $\geq$  3.3)

**Document ID: 112464**  
Release: 9  
Version: 145  
Doc. Status: APPROVED  
Last modified: 26.04.2017

**Contact info**  
GasSecure AS  
Hoffsveien 70 C  
N-0377 Oslo  
Norway  
[www.gassecure.com](http://www.gassecure.com)  
[post@gassecure.com](mailto:post@gassecure.com)

### Note

Those who have or will have the responsibility for the operation or maintenance of this product must carefully read this manual. The product may not perform as designed if it is not used and maintained in accordance with the manufacturer's instructions.



Please read the complete manual and particularly note the paragraphs having an exclamation mark in the margin.

This manual covers installation, operation and maintenance of the GS01 wireless hydrocarbon detector and its battery pack.

The product warranty issued by GasSecure is voided if the product is not used and maintained as described in this manual.

Please read also the safety instructions in Section 6.

© GasSecure AS, all rights reserved.

## PRODUCT DATA

Manufacturer	GasSecure AS
Country of origin	Norway
Models	GS01, GS01-EA
Gases	Hydrocarbons
Range Methane configuration	0 – 100% LEL
Range Propane configuration	0 – 80% LEL
Environmental conditions	
Operating temperature	-30°C to +55°C
Humidity	0 to 90 RH <sup>1</sup> non-condensing
Pressure influence, 700 – 1300 hPa <sup>2</sup>	≤ 0.15% of reading per hPa (at 50% LEL)
Protection classification	IP 66 and IP 67 <sup>3</sup>
Storage temperature	-40°C to +65°C
Storage pressure	700 to 1300 hPa
Electrical	
RF output power GS01	≤ 12 dBm EIRP
RF output power GS01-EA	≤ 16 dBm EIRP
Battery type	Lithium-Thionyl Chloride
Battery cells	Tadiran SL-2780/S or TL-5930/S
Average power	5 mW
Explosion Protection	II 2G Ex ib IIC T4 Gb -30°C to +55°C
Intrinsic safety temperature	-40°C to +65°C
Gas performance temperature	-30°C to +55°C

<sup>1</sup> The manufacturer verified conditions are 0-100% RH and condensing.

<sup>2</sup> Applies only for Methane configuration and outside the pressure range 850 – 1150 hPa: The process value (PV) must be replaced with the adjusted process value PV<sub>adj</sub>. PV<sub>adj</sub> is calculated by the controller with the measured atmospheric pressure as input according to formula  $PV_{adj} = \left(\frac{p}{p_0}\right)^{-1.5} PV$ , where p is the measured pressure and p<sub>0</sub> is the standard atmospheric pressure (101 kPa). Pressure p must be measured with +/-10 kPa accuracy.

<sup>3</sup> IP ratings do not imply that the equipment will detect gas during exposure to those conditions.

## TABLE OF CONTENTS

<b>1. PRODUCT DESCRIPTION .....</b>	<b>5</b>
1.1 GENERAL .....	5
1.2 MEASURING PRINCIPLE .....	5
1.3 INSTRUMENT DESCRIPTION.....	6
1.4 BATTERY .....	6
1.5 OUTLINE DIMENSIONS .....	6
<b>2. INSTALLATION.....</b>	<b>9</b>
2.1 TOOLS .....	9
2.2 MOUNTING .....	9
2.3 GROUNDING .....	10
2.4 SUN SHADE / WEATHER PROTECTION .....	10
2.5 EXTERNAL ANTENNA (APPLIES ONLY FOR GS01-EA) .....	10
<b>3. COMMISSIONING.....</b>	<b>12</b>
3.1 COMMUNICATION .....	12
3.2 ISA100 WIRELESS™ STANDARD.....	12
3.3 ISA100 OBJECTS.....	12
3.4 GS01 DATA FORMAT DETAILS.....	14
3.5 MODIFICATION OF LEL.....	14
3.6 COMMUNICATION MONITORING .....	15
3.7 GS01 DETECTOR PROVISIONING .....	15
3.8 MODIFICATIONS TO AN EXISTING NETWORK .....	18
3.9 VISUAL AND FUNCTIONAL CHECK .....	19
<b>4. OPERATION.....</b>	<b>20</b>
4.1 NORMAL OPERATION.....	20
4.2 PROOF TEST (VALIDATION).....	20
<b>5. MAINTENANCE .....</b>	<b>22</b>
5.1 ROUTINE MAINTENANCE .....	22
5.2 SPARE PARTS AND ACCESSORIES.....	22
5.3 CLEANING .....	23
5.4 BATTERY PACK.....	23
5.5 STORAGE .....	26
5.6 TROUBLESHOOTING .....	26
5.7 CONTACT GASSECURE FOR SUPPORT .....	27
<b>6. SAFETY INSTRUCTIONS.....</b>	<b>29</b>
<b>7. CERTIFICATIONS AND STANDARDS.....</b>	<b>30</b>
7.1 STANDARDS .....	30
7.2 REGULATORY COMPLIANCE OF RADIO FOR GS01 .....	31
7.3 MARKING .....	31
<b>8. TECHNICAL DATA .....</b>	<b>35</b>
8.1 PERFORMANCE CHARACTERISTICS.....	35
8.2 CROSS SENSITIVITIES .....	36
<b>9. REFERENCES .....</b>	<b>38</b>
<b>10. APPENDIX .....</b>	<b>39</b>

## FIGURES

FIGURE 1-1: GS01 DETECTOR LAYOUT.....	6
FIGURE 1-2: GS01 DETECTOR WITH DIMENSIONS IN [MM].....	7
FIGURE 1-3: GS01-EA DETECTOR WITH DIMENSIONS IN [MM].....	8
FIGURE 1-4: GS01 MEASURING CELL DETAILS.....	8
FIGURE 2-1: CORRECT POSITION OF THE WEATHER CAP AND LOCATION OF EARTH POINT.....	10
FIGURE 2-2: GS01-EA LAYOUT WITH ANTENNA CONNECTIONS.....	11
FIGURE 3-1: GS01 CONFIGURATOR.....	17
FIGURE 5-1: BATTERY PACK WARNING LABEL.....	24
FIGURE 5-2: BATTERY PACK BOTTOM VIEW.....	25
FIGURE 5-3: BATTERY PACK TOP AND BOTTOM.....	25
FIGURE 7-1: GS01 PRODUCT IDENTIFICATION PLATE.....	31
FIGURE 7-2: GS01-EA PRODUCT IDENTIFICATION PLATE.....	32
FIGURE 7-3: GS01 PRODUCT IDENTIFICATION PLATE – FM APPROVED.....	32
FIGURE 7-4: GS01-EA PRODUCT IDENTIFICATION PLATE – FM APPROVED.....	32
FIGURE 7-5: FCC COMPLIANCE LABEL.....	33
FIGURE 7-6: BATTERY PACK IDENTIFICATION LABEL (FM APPROVED VERSION TO THE RIGHT).....	34
FIGURE 7-7: ANTENNA IDENTIFICATION LABEL (FM APPROVED VERSION TO THE RIGHT).....	34
FIGURE 10-1: EU DECLARATION OF CONFORMITY FOR GS01 AND GS01-EA.....	42

## TABLES

TABLE 2-1: PROPERTIES OF STANDARD ANTENNA CABLE FOR THE GS01-EA.....	11
TABLE 3-1: ISA100 OBJECTS.....	13
TABLE 3-2: LEL VALUES IN [% VOL] ACCORDING TO IEC AND NIOSH.....	14
TABLE 3-3: PV GAS MEASUREMENT DATA INTEGRITY.....	15
TABLE 4-1: RECOMMENDED GAS CONCENTRATIONS FOR VALIDATION.....	21
TABLE 5-1: IMPORTANT SPARE PARTS AND ACCESSORIES FOR THE GS01.....	22
TABLE 5-2: STATUS MESSAGES RETRIEVED FROM THE DIAG_STATUS ATTRIBUTE.....	27
TABLE 7-1: LIST OF APPLICABLE STANDARDS FOR THE GS01.....	30
TABLE 8-1: PERFORMANCE CHARACTERISTICS FOR THE GS01.....	35
TABLE 8-2: LEL VALUES IN [% VOL] ACCORDING TO IEC60079-20.....	36
TABLE 8-3: CROSS SENSITIVITIES FOR A GS01 METHANE DETECTOR.....	36
TABLE 8-4: CROSS SENSITIVITIES FOR A GS01 PROPANE DETECTOR.....	36
TABLE 8-5: LEL VALUES IN [% VOL] ACCORDING TO NIOSH.....	36
TABLE 8-6: CROSS SENSITIVITIES FOR A GS01 METHANE DETECTOR.....	37
TABLE 8-7: CROSS SENSITIVITIES FOR A GS01 PROPANE DETECTOR.....	37
TABLE 10-1: PV_STATUS BYTE DESCRIPTION ACCORDING TO ISA100 WIRELESS™ STANDARD.....	39
TABLE 10-2: CONTENT OF THE DIAG_STATUS ATTRIBUTE.....	39

## 1. PRODUCT DESCRIPTION

### 1.1 General

The GS01 is a wireless, battery powered point detector that monitors the concentration of hydrocarbon gases.

It uses a combination of two sensors:

1. An ultrasonic speed-of-sound sensor that continuously monitors changes in the ambient air composition.
2. An optical (infrared) absorption sensor that is used for accurate measurements of the hydrocarbon gas concentration.

The infrared sensor uses more power than the ultrasonic and is therefore kept in watch mode if the ultrasonic sensor does not detect any changes in the air composition. The infrared sensor applies optical MEMS (micro electromechanical system) technology to enable intermittent operation with fast start-up and measurement, and thus very low average battery consumption.

The measured gas concentration is transmitted wireless using the ISA100 Wireless™ standard. This manual does not cover the wireless router or gateway and the connected control system (please refer to the list of references in Section 9 providing examples of relevant documentation).

The detector is intrinsically safe, with equipment protection level Gb (Ex ib) (see Section 7) intended for use in zone 1 and 2 areas.

Two models are available of this gas detector:

- GS01 with fixed antenna
- GS01-EA with extended antenna

All information in this manual for the GS01 also applies for the GS01-EA unless explicitly otherwise noted.

### 1.2 Measuring principle

The GS01 detector utilises infrared absorption spectroscopy. The fundament is the Beer-Lambert Law, which relates the absorption of light to the properties of the material through which the light is travelling.

The internal radiation source emits infrared radiation through a lens and a sapphire window into the measuring cell (cf. Figure 1-1 and Figure 1-4). A mirror at the opposite end of this cell returns the beam back through the sapphire window into the internal volume of the detector and onto a filter that disperses, focuses, and modulates the incident light. This filter is a patented silicon MEMS component proprietary to GasSecure.

By applying a control voltage to the MEMS chip it is switched between the so-called gas state and the reference state. In the gas state a wavelength where hydrocarbons do absorb light is focused onto the detector, whereas two

wavelengths where hydrocarbons do not absorb are focused onto the detector in the reference state. The GS01 detector uses the same light source, light path and photodetector for both measurements.

This single beam, triple wavelength detection is unique to the GS01 from GasSecure.

### 1.3 Instrument description

The GS01 consists of the main housing (316L stainless steel) with mounting bracket, the measuring cell, an antenna (note that the GS01-EA features an antenna connector instead), and the battery compartment (cf. Figure 1-1). Attached to the main housing are the following detachable parts:

- Weather cap (Polyamide 6)
- Battery cap (Polyamide 6)
- Battery package (Polyamide 6)

Except for these detachable parts, the user shall not disassemble the sensor any further. When the weather cap is removed, the infrared measuring cell with the sapphire window on the main housing and the mirror at the outer end, is open and accessible for cleaning. The ultrasonic sensor is protected by a perforated steel sheet, which shall not be removed.

### 1.4 Battery

The GS01 may only be used with the GasSecure battery pack (Part number 10055). The battery pack is designed for two Lithium-Thionyl Chloride size D cells in series, and has a nominal output voltage of 7.2V. The battery pack has an internal charge counter. The battery pack is intrinsically safe (see Section 7).

### 1.5 Outline dimensions

Figure 1-1 shows the sensor buildup with an exploded drawing. Figure 1-2 and Figure 1-3 depict the GS01 and GS01-EA dimensions, respectively.

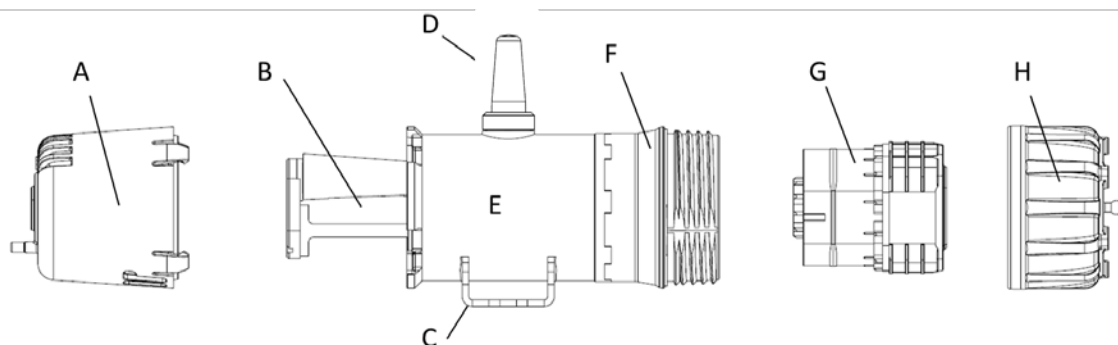

Figure 1-1: GS01 detector layout

with A) Weather cap, B) Measuring cell, C) Mounting bracket, D) Antenna, E) Stainless steel housing, F) Battery compartment, G) Battery pack, H) Battery cap

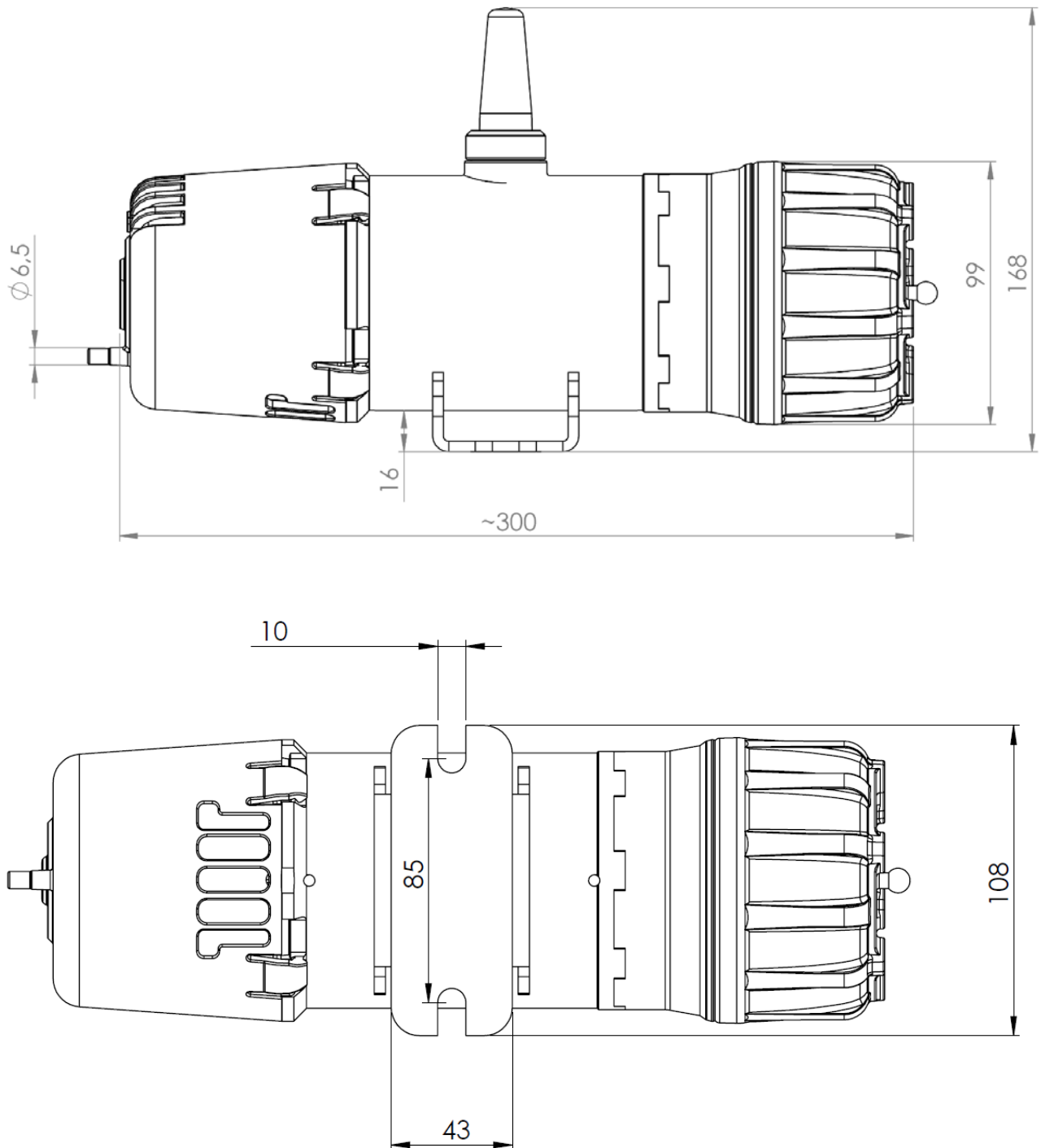

Figure 1-2: GS01 detector with dimensions in [mm]



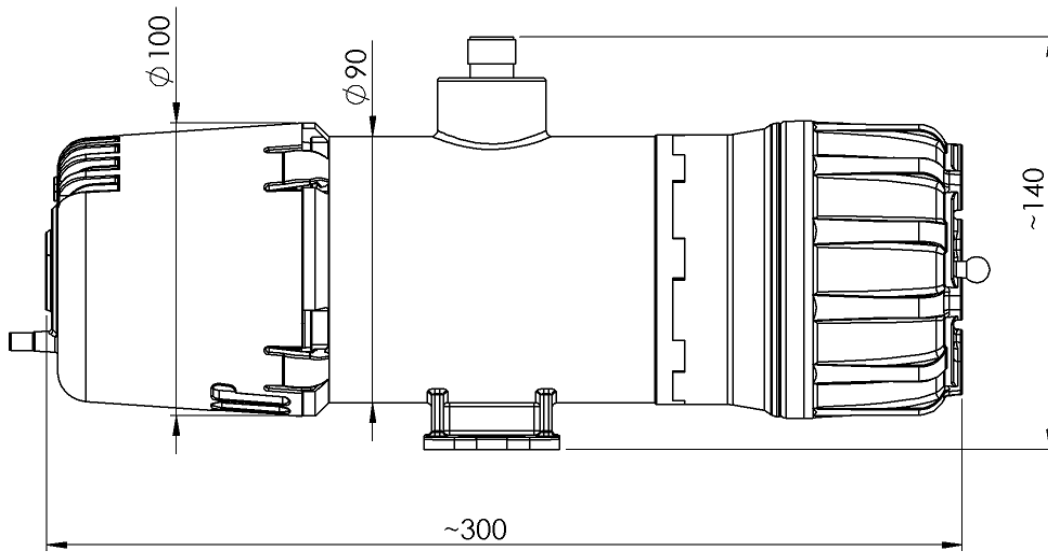

Figure 1-3: GS01-EA detector with dimensions in [mm]

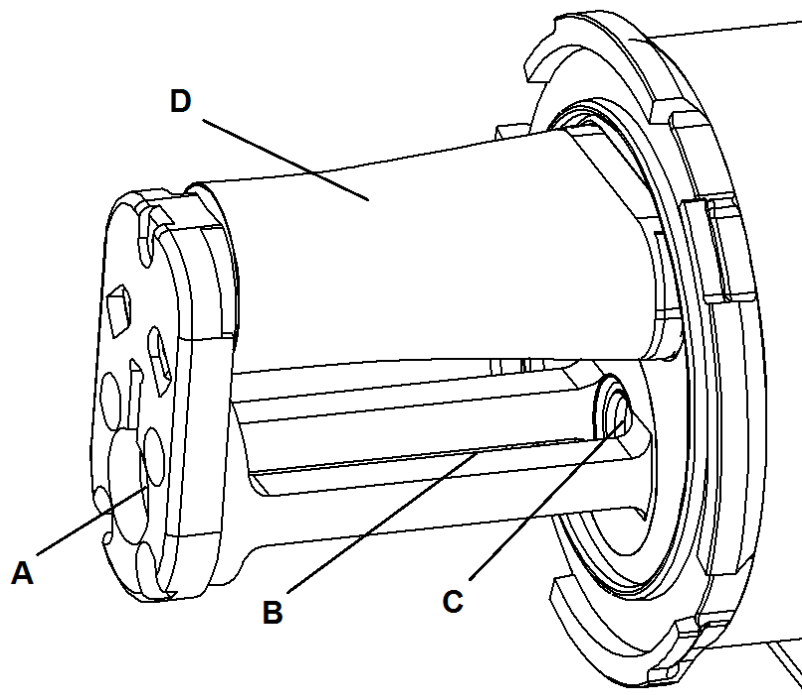

Figure 1-4: GS01 measuring cell details  
showing A) External mirror, B) Infrared beam path, C) Sapphire window, D)  
Ultrasonic sensor with protective sheet

## 2. INSTALLATION



Note: The GS01 gas detector certification must comply with the legal requirements following the area classification at the installation point.

The detector shall be installed where it is most likely to detect gas in the event of a leakage.

For battery pack installation see Section 5.4.

In areas with significant exposure to direct sunlight and the risk of temperatures beyond the operating temperature range, a sunshade should be considered (see list of spare parts in Table 5-1).

### 2.1 Tools

The following tools are needed to install the instrument:

- Open-end spanner for M8 bolts (alternatively 5/16" bolts)
- Face spanner with two pins in size 75x6 (distance x pin diameter) as optional tool to remove the battery cap
- Torx screwdriver T10 for battery cell replacement (cf. Section 5.4.2)

### 2.2 Mounting

The detector is mounted with its long axis horizontally. For the standard GS01 make sure, to the extent possible, that the antenna is vertical (pointing up or down) and that local radio shadowing is kept at a minimum. The GS01-EA may be mounted in any horizontal orientation.

Two M8 bolts (alternatively 5/16" bolts) with washers under the head are used to attach the bracket. The bolts should be spaced from 85 to 95 mm to easily fit the slots when mounting the detector.



The weather cap must be mounted with the arrow on the cap pointing upwards, regardless if the antenna is pointing up or down (cf. Figure 2-1). If possible, mount the GS01 with the weather cap oriented away from the prevailing wind direction.

Do not use the GS01 detector in ventilation ducts or pipes.

Do not mount the detector directly above hot or cold surfaces. If the detector is mounted inside metallic structures or enclosures the GS01 detector with extended antenna (GS01-EA) should be considered.

## 2.3 Grounding



The detector housing must be connected to ground for operation in hazardous areas. This to avoid possible static charge build-up, which may arise from electrically isolated metal parts. Ground the detector either by mounting it on a grounded metallic structure or by connecting a grounded wire to the screw holes in the mounting bracket (cf. Figure 2-1). The resistance to ground must be less than 1 GOhm.

## 2.4 Sun shade / weather protection

The sunshade is available as optional accessory and recommended for locations with high ambient temperature and / or direct sunlight exposure. It may also be used as weather protection for instance in locations with frequent heavy precipitation. The shade is fixed to the gas detector bracket with the same M8 (or 5/16") bolts, which are used for detector mounting. Make sure that the sunshade is mounted the correct way so that the detector identification plate remains visible.

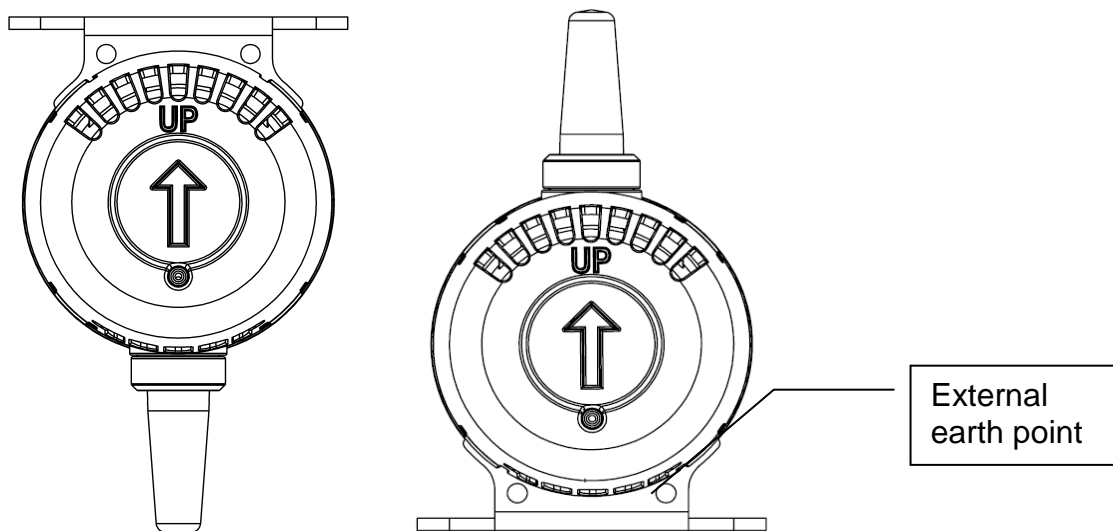

Figure 2-1: Correct position of the weather cap and location of earth point.

The arrow must always point up regardless of the detector orientation.

## 2.5 External antenna (applies only for GS01-EA)



The external antenna is connected to the detector with the antenna cable as shown in Figure 2-2. The properties of the antenna cable supplied by GasSecure are shown in Table 2-1. The GS01-EA detector is certified with the coaxial cable and the omni-directional antenna in Table 5-1. Note that the approved cable length range is 0-30 m. Do not connect any other antennas than those listed in Table 5-1.

The external antenna is delivered with a bracket (refer to Reference [10] for bracket dimensions) and metal bands for easy fitting to a pole (25 – 101 mm) or

similar. Make sure, to the extent possible, that the antenna is mounted vertical (pointing up or down) and that local radio shadowing is kept at a minimum. Please read also the safety instructions in Section 6.

Table 2-1: Properties of standard antenna cable for the GS01-EA

Loss/m at 2.5 GHz [dB]	Diameter [mm]	Bend radius [mm]	Weight per m [g]
0.21	10.3	100	115

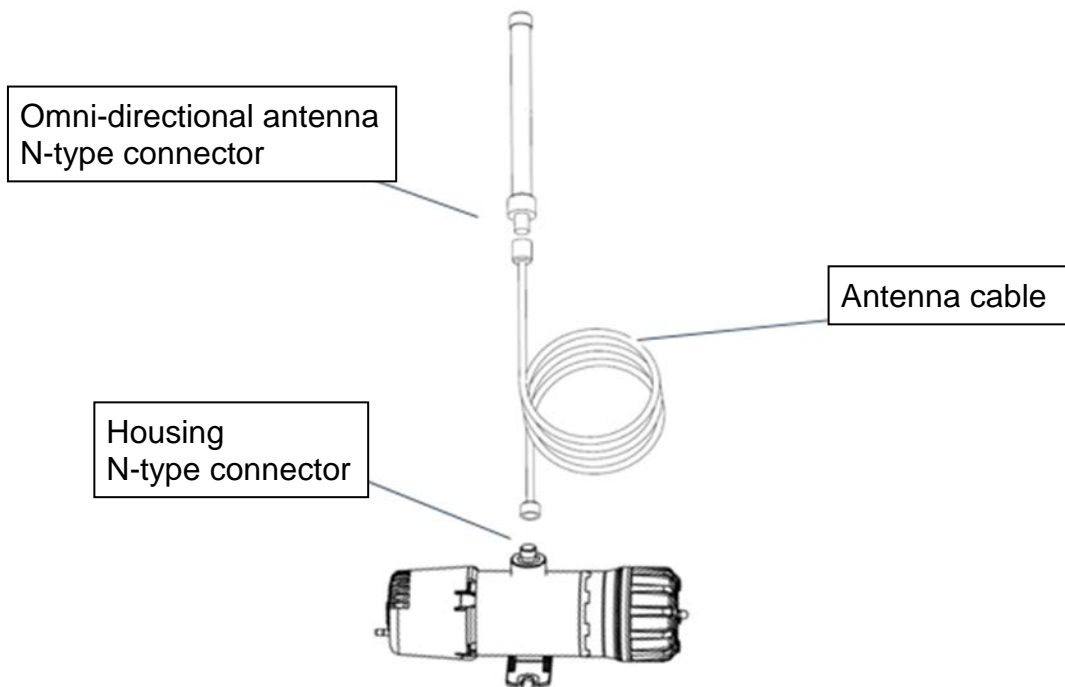

Figure 2-2: GS01-EA layout with antenna connections

### 3. COMMISSIONING

The GS01 detector(s) is (are) set up in a wireless sensor network with a gateway and router. The exact commissioning procedure depends on the selected type of gateway. Therefore, this manual must be used together with the relevant documentation written for the respective gateway. Some references for such documentation are provided in Section 9.



On completion of commissioning, the proof test, as described in Section 4.2, should be executed to validate the correct mapping of the detector output data.

#### 3.1 Communication

The GS01 detector complies with the ISA100 Wireless™ standard for wireless communication.

Each GS01 detector must be paired with a single gateway, before it can communicate with the network. The gateway is the interface between the wireless and plant networks. It marks the transition between communications compliant to the standard and other communications, and acts as a translator between ISA100 Wireless™ and other protocols (Modbus, PROFINET, etc.).

The pairing process, where the device obtains the appropriate security credentials and network-specific information, is referred to as provisioning and is explained in Section 3.7.

#### 3.2 ISA100 Wireless™ standard

ISA100 Wireless™ is a wireless networking technology standard developed by the International Society of Automation (ISA).

This ISA standard is intended to provide reliable and secure wireless operation for safety, control, and monitoring applications. This standard defines the protocol suite, system management, gateway, and security specifications for low-data-rate wireless connectivity with fixed, portable, and moving field devices supporting very limited power consumption requirements. The application focus is to address the performance needs for periodic monitoring and process control where latencies on the order of 100 ms can be tolerated with optional behaviour for shorter latency.

#### 3.3 ISA100 objects

ISA100.11a defines a communication protocol, with an application layer that includes a simple but extensible set of input and output objects.

The GS01 detector publishes the measured values and diagnostic information as ISA100 objects with attributes. It is distinguished between standard attributes and GS01 device specific attributes.

##### 3.3.1 Standard objects

The GS01 publishes ISA100 standard objects with attributes for process value and diagnostic status as outlined in Table 3-1 below. The gas measurement value

is sent as User Application - Analog Input Object with the attribute “Process Value” (PV). Note that the user may choose which gas configuration to read out by selecting the corresponding PV object (Methane or Propane) for publication. The device health information is compiled and sent as User Application Management Object with the attribute “Diagnostic Status” (DIAG\_STATUS).

The concentrator of the gas detector is per default set up to publish the gas measurement and the diagnostic status. The concentrator can be configured differently in the gateway interface.

For short detector response time (<5 sec as per GS01 datasheet), the gateway must be set up with a 2 sec sampling interval (also referred to as publication period). In the absence of hydrocarbon gas, the detector will not publish on all available time slots, but per default only publish on every 6<sup>th</sup> time in order to save battery power. In the presence of hydrocarbon gas of sufficient concentration (defined by the internal low alarm limit see Table 8-1), all time slots will be used.

*Table 3-1: ISA100 objects*

Descriptive name	Access-ibility	Octet no.	Content	Modbus input registers	Data type
PV (Methane or Propane)	READ	1	PV_Status	Register N	32 bit (4 octets) float, according to IEEE 754_Float32
		2	PV_Value (1/4)	Register N+1	
		3	PV_Value (2/4)		
		4	PV_Value (3/4)	Register N+2	
		5	PV_Value (4/4)		
DIAG_STATUS	READ	1	Diag_Status (1/4)	Register M	UINT 16 bit
		2	Diag_Status (2/4)		
		3	Diag_Status (3/4)	Register M+1	
		4	Diag_Status (4/4)		

The content of the PV\_Status byte (PV = process value) is explained in Table 10-1 in the Appendix.

The full mapping of the content of the DIAG\_STATUS attribute is explained in Table 10-2 in the Appendix.



Note that a controller is required to display the diagnostic information including fault or alarm conditions.

Recommendations for which status and diagnostic information to integrate in the control and maintenance loop are also provided in the Appendix.

### 3.3.2 GS01 specific objects for safe communication

In addition to the standard objects, the GS01 can be configured to publish and subscribe to the custom data object “SafeData”. This object is used for safe

communication. The GS01 uses the PROFIsafe profile over PROFINET as tool for safe communication. In this setup the GS01 acts as F-Slave, a passive communication peer able to perform PROFIsafe. Its counterpart is the F-Host, a data processing unit able to perform PROFIsafe and to trigger the F-Slave for data exchange. The F-Host must be compliant with the PROFIsafe requirements so that end-to-end communication through a black channel, defined by the IEC 61508 standard, can be established.

Please refer to the GS01 safety manual [RD 9] for further information on how to set up safe communication with PROFIsafe. For applications without PROFIsafe the “SafeData” object shall be disregarded.

### 3.4 GS01 data format details

The GS01 data objects can be mapped into 16 bit Modbus input registers. The “PV” object (cf. Section 3.3.1) normally populates three registers; the PV\_Status byte populates the last 8 bits of the first register and the 32 bit float number populates the following two registers.

The “UAPMO.DIAG\_STATUS” object (cf. Section 3.3.1) is normally mapped into two 16 bit registers. Some gateways will also add a status byte into the preceding register. This status byte may be ignored, because its information is already contained in the PV\_status byte.

The procedure for Modbus register mapping depends on the specific gateway, please consult the respective gateway manual on how to achieve this mapping. GasSecure can assist with advice if needed.

### 3.5 Modification of LEL

Regionally different conversion factors may apply for the display of measured concentrations in percent of the lower explosion limit (LEL). The GasSecure GS01 gas detector allows you to select one of two LEL categories, which basically correspond with common explosion limits in the USA (NIOSH Pocket Guide to Chemical Hazards<sup>4</sup>) and Europe IEC 60079-20), cf. Table 3-2. The factory default setting is LEL according to IEC. The LEL category may be changed with the GS01 Configurator tool as part of device provisioning as explained in Section 3.7. Note that this feature is supported for GS01 firmware version  $\geq 3.3$ .

*Table 3-2: LEL values in [% vol] according to IEC and NIOSH*

LEL values [% vol] for	IEC (factory default)	NIOSH
Methane	4.4	5.0
Propane	1.7	2.1

<sup>4</sup> See <http://www.cdc.gov/niosh/npg/>

### 3.6 Communication monitoring

The PV\_Status byte (see Table 3-1) can be used for monitoring the communication status and the data integrity. See Table 10-1 in the Appendix for all details. With no error present (e.g. beam block or critical low power) and the detector communicating with the gateway, the status byte will be decimal value 64 or higher; please refer to Table 3-3 below for the three main classes of data integrity.

The status byte is updated by the gateway if the communication with the detector is lost. The time from reception of the last packet and until the status byte is updated to flag “lost communication” is defined via the stale limit parameter. Please consult the gateway manual for information about setting this stale limit.



GasSecure’s recommendation is a sampling interval of 2 sec (see Section 3.3.1) together with a stale limit of 30 times, so that “lost communication” is flagged after maximum 60 sec. Under no circumstances the stale limit must be set to less than 6, because this would disable communication between detector and gateway.

Note that the timeout, as defined by the stale limit, can be checked by removing the battery and monitoring the time until the PV\_Status byte is updated.

*Table 3-3: PV Gas measurement data integrity*

Data integrity	Octet decimal number	Explanation and actions
Bad	< 64	No communication or hardware failure. Check communication. Contact GasSecure if this failure persists.
Uncertain	64 to 127	The integrity of the data is uncertain. As example, the sensor range or temperature range may be exceeded.
Good	= 128	Normal operation. The detector is providing reliable gas measurements.

### 3.7 GS01 detector provisioning

All GS01 detectors have to be provisioned so that they will join the correct network. Provisioning the GS01 requires the following:

- The GS01 serial adapter together with the GS01 Configurator software (both accessories from GasSecure)
- FTDI virtual comport driver for the GS01 serial adapter
- The network (or subnet) ID of the gateway or backbone router
- For Yokogawa gateway only: A Capability File (CF) for the GS01 device.



Software tools, drivers, and files (e.g. CF) are available for download at <http://tools.gassecure.com>.

This procedure can be carried out with an unprovisioned GS01 or with a GS01 that earlier has been provisioned to another gateway.

### 3.7.1 Yokogawa gateways

- a) Connect the GS01 to a PC with the GS01 Configurator installed using the GS01 serial adapter.
- b) Run the GS01 Configurator and select the correct COM port. Keep the default mode "Provision one GS01 device". Press the "Connect" button and verify that the device information is displayed, cf. Figure 3-1. Press the "Read version info" button if the device information does not show automatically. Press the "Read" button so that the current provisioning status of the device is displayed.
- c) Enter the device tag and the required network ID in decimal format, cf. Figure 3-1.
- d) For the join key there are two options.
  - i. Specific (user-defined) join key: Type a 32-bit hexadecimal number in the "join key" field.
  - ii. Generate a random join key: Press the "Generate random join key" button.
- e) Check and set the LEL category to either IEC or NIOSH as defined in Table 3-2.
- f) Check the destination folder for the ypif file and change it by pressing the "..." button if necessary. Press the "Generate ypif file" button. This file must be uploaded to the gateway (explained in reference [RD 4]) to enable communication. Press the "Apply" button (do not make any changes to the provisioning input data between pressing the two buttons!).
- g) Close and exit the GS01 Configurator and disconnect the GS01 detector from the PC.
- h) Power up the GS01 by inserting the battery pack.
- i) The GS01 device should join the network within 5-20 minutes, if it is within radio distance to the gateway and the gateway is set up properly (refer to reference [RD 4]). If the gateway is out of radio range, the GS01 device will try to connect for a period of 60 min and then enter a power-saving mode. In this mode it will try to connect for a 5 min period once per hour.

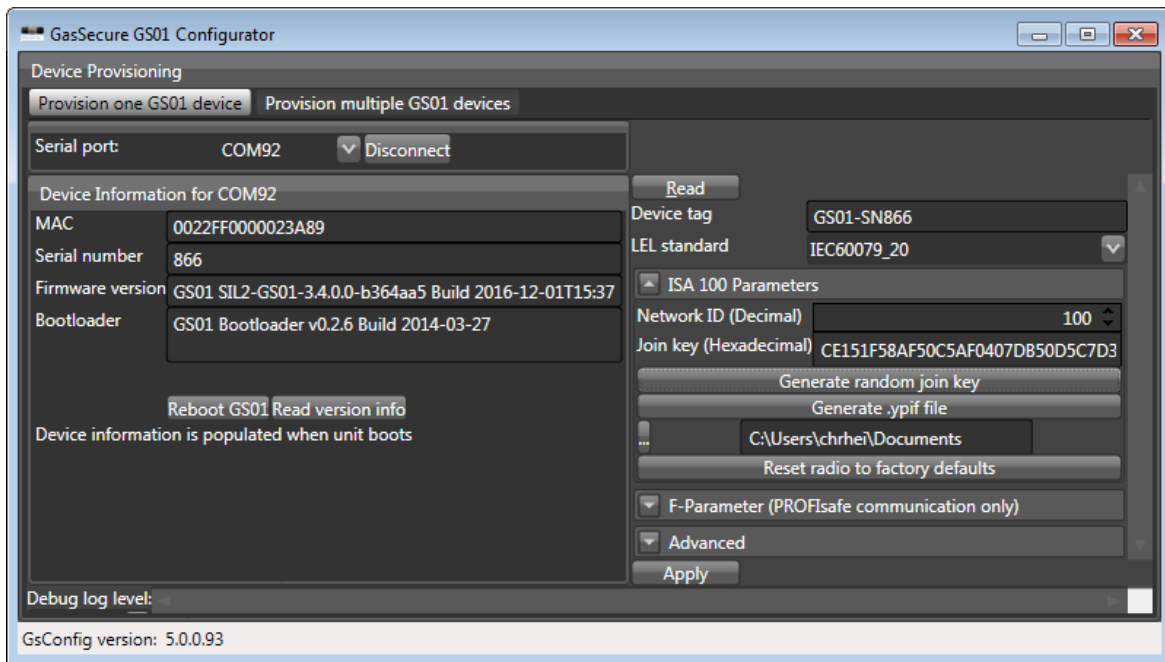

Figure 3-1: GS01 Configurator

### 3.7.2 Nivis gateway VR800/900

- a) Connect the GS01 to a PC with the GS01 Configurator tool installed using the GS01 serial adapter.
- b) Run the GS01 Configurator and select the correct COM port. Keep the default mode “Provision one GS01 device”. Press the “Connect” button and verify that the device information is displayed, cf. Figure 3-1. Press the “Read version info” button if the device information does not show automatically. Press the “Read” button so that the current provisioning status of the device is displayed as well.
- c) Enter the device tag and the required network ID in decimal format, cf. Figure 3-1.
- d) For the join key there are two options.
  - i. Specific (user-defined) join key: Type a 32-bit hexadecimal number in the “join key” field.
  - ii. Generate a random join key: Select “randomize join key”. Press the “Generate random join key” button.

Note down the join key. It is needed for configuring the Nivis gateway.

- e) Check and set the LEL category to either IEC or NIOSH as defined in Table 3-2.
- f) Press the “Apply” button.
- g) Close and exit the GS01 Configurator and disconnect the GS01 detector from the PC.

- h) Power up the GS01 by inserting the battery pack.
- i) The GS01 device should join the network within 5-20 minutes, if it is within radio distance to the gateway and the gateway is set up properly. If the gateway is out of radio range, the GS01 device will try to connect for a period of 60 min and then enter a power-saving mode. In this mode it will try to connect for a 5 min period once per hour.

### 3.7.3 Over the air (OTA) provisioning

- a) Connect the GS01 to a PC with the GS01 Configurator installed using the GS01 serial adapter.
- b) Run the GS01 Configurator and select the correct COM port. Keep the default mode "Provision one GS01 device". Press the "Connect" button and verify that the device information is displayed, cf. Figure 3-1. Press the "Read version info" button if the device information does not show automatically. Press the "Read" button so that the current provisioning status of the device is displayed.
- c) Press the "Reset radio to factory defaults" button.
- d) Close and exit the GS01 Configurator and disconnect the GS01 detector from the PC.
- e) Power up the GS01 by inserting the battery pack.
- f) The GS01 can now be provisioned over the air (OTA) using either special field tools or the field wireless access points. Refer to references [RD3], [RD6] or [RD 8] for possible solutions from different vendors.

## 3.8 Modifications to an existing network

1. Add a detector  
Provision the GS01 as described in Section 3.7.  
Mount the GS01 with battery.  
Re-configure the gateway to accommodate the additional detector(s) (cf. Section 9 for gateway relevant documentation).
2. Replace a detector  
Power down the GS01 in question by removing its battery.  
Provision the replacement GS01 by following all steps in Section 3.7.  
Mount the replacement GS01 with battery.  
Re-configure the gateway to accommodate the replacement detector(s) (cf. Section 9 for gateway relevant documentation).
3. Remove a detector  
Power down the GS01 in question by removing its battery pack.  
Optional: Re-configure the gateway in order to remove the detector from the list of publishers (cf. Section 9 for gateway relevant documentation).

### **3.9 Visual and functional check**

The following activities are recommended before putting into operation the GS01 detector:

- The axis of the detector shall be horizontal.
- Verify the correct orientation of the weather cap (cf. Figure 2-1).
- Check that all bolts and screws are securely tightened.
- Carry out a validation as described in Section 4.2.
- It is moreover recommended to read the procedures described in IEC 60079-29-2 for reference.

## 4. OPERATION



The GS01 has no user adjustable parts. Do not open the instrument. Opening the GS01 detector voids the warranty issued by the manufacturer.

### 4.1 Normal operation

After provisioning the GS01 detector with an ISA100 Wireless™ gateway, it will perform the following tasks:

- Measure gas concentration
- Publish gas concentration to the gateway
- Publish other diagnostic information to the gateway

### 4.2 Proof test (Validation)

Referring to Section 3.5, note that the GS01 is set to detect gas on a % LEL scale either according to IEC60079-20 or to NIOSH.

Although no re-calibration of the GS01 is necessary, it is recommended to check the response of the detector at least every second year by applying pressurized test gas.

The weather cap is designed for validation, as it includes a 6 mm diameter tube fitting for efficiently filling the GS01 measuring cell with a test gas mixture. Note however that the test gas will leak out during testing and leakage will depend on the wind speed. Therefore, the measured gas concentration is normally lower than stated on the test gas cylinder. It is not recommended to carry out validation in stronger wind, or alternatively the weather cap has to be covered on the outside for example by applying tape to the openings.

The function of the detector is positively validated as long as it responds to the test gas.

Please refer to Table 4-1 for the recommended gas mixtures and expected instrument readings. Apply the test gas through a 6 mm tube from a gas cylinder with pressure regulator. It is recommended to adjust the flow to at least 5 L/min.

*Table 4-1: Recommended gas concentrations for validation*

<b>Detector version and LEL category</b>	<b>Recommended test gas</b>	<b>Expected reading</b>
Methane, IEC	Methane 2.2 % vol in synthetic air	50 % LEL
	Or alt. 2.5 % vol in synth. air	57 % LEL
Propane, IEC	Propane 0.42 % vol in synthetic air	25 % LEL
	Or alt 1.0 % vol in synth. air	59 % LEL
Methane, NIOSH	Methane 2.5 % vol in synthetic air	50 % LEL
Propane, NIOSH	Propane 0.42 % vol in synthetic air	20 % LEL
	Or alt 1.0 % vol in synth. air	48 % LEL

## 5. MAINTENANCE

The GS01 detector is designed for minimum maintenance.



The instrument does not have user adjustable parts. Do not attempt to open or disassemble the instrument. This can compromise safety and performance. Opening the GS01 voids the warranty issued by the manufacturer. All repairs have to be done by the manufacturer or by an authorised dealer.

### 5.1 Routine maintenance

For best performance it is recommended to routinely carry out the following steps:

- Clean the window and mirror when necessary (see Section 5.3 below). The optical transmission of the infrared sensor maybe monitored with the DIAG\_STATUS attribute explained in Table 5-2 and Table 10-2.
- Check the weather cap regularly to make sure it is not clogged (see Section 5.3 below).
- Check battery status regularly. Replace low batteries in due time (see Section 5.4 below). The battery status maybe monitored with the DIAG\_STATUS attribute explained in Table 5-2 and Table 10-2.
- Check the detector response at least every second year (see Section 4.2).

### 5.2 Spare parts and accessories

*Table 5-1: Important spare parts and accessories for the GS01*

Description	GasSecure p/n	Dräger p/n
Battery pack	10055	AL20712
O-ring for battery compartment	30410	--
Weather cap	10078	AL20709
Battery cap	10022	AL20708
Sunshade	10123	AL20711
GS01 serial adapter	10156	AL20710
6 dBi antenna (only for GS01-EA)	10204	AL20718
Standard antenna cable for GS01-EA, 5m	10200-5	AL20719

### 5.3 Cleaning

In the event of low or blocked optical transmission of the IR sensor, the optical window and external mirror (see Figure 1-4 for their exact location) should be cleaned.

Please proceed as follows:

- Remove battery to avoid unwanted alarms while cleaning.
- Use soft tissue or a cotton swab and a lens cleaning fluid based on pure water and isopropyl alcohol (IPA) and/or other alcohols.
- Flush or wipe with pure water afterwards, and dry off with a soft dry tissue.
- Reinstall the battery.
- Note that gas alarms are likely to occur during and shortly after cleaning due to the detector's sensitivity to alcohol. This is avoided by removing the battery while cleaning.
- Other cleaning agents are not recommended, but if lens cleaning fluid or IPA is not available, a diluted dishwasher detergent may be used if followed by a thorough flushing with pure water. Dry off any remaining water droplets.

The inside of the ultrasonic sensor does not need cleaning. If the perforated sheet is clogged with dirt, clean compressed air may be used for removal.

If the detector is installed in an area where the weather cap may become clogged (for instance by insects, leaves, ice or snow), it is recommended that this cap is inspected regularly to make sure that air flows freely through the openings.

### 5.4 Battery pack

Note that the GS01 may only be operated with the GasSecure battery pack (p/n 10055).

#### 5.4.1 Battery pack replacement

The battery pack is installed or replaced simply by twisting off the battery cap, pulling out the old pack, pushing the new one in place, and putting back the cap. Make sure that the O-ring fits and tightens on the entire circumference of the battery compartment. The battery pack will only fit one way, so that correct polarity is ensured. After inserting the battery pack, it may take up to 15 minutes before the detector is transmitting data, depending on how the network is set up.

#### 5.4.2 Battery cell replacement

The battery cells in the battery pack can be replaced. Assemble the battery pack as described below.



Caution!  
Only use battery packs that



- are designed for battery cell replacement. They will contain the label depicted in Figure 5-1. Battery packs without this label may not be opened.
- are clean and free of contamination.
- are visually intact (particularly no damage around the screw holes).
- have no visible corrosion on the terminal contacts.

Use only the following approved battery cells in the battery pack:

- Tadiran model no. SL-2780/S
- Tadiran model no. TL-5930/S

Battery cell replacement and opening the battery pack must take place in a safe area, where a potential explosive atmosphere is not present.

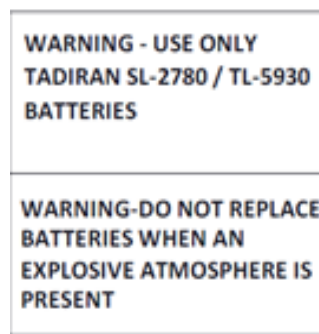

*Figure 5-1: Battery pack warning label*

Replacement:

- Loosen the two battery pack mounting screws (Torx T10), see Figure 5-2. Note that the spring force is high, have therefore a firm grip around the pack while unscrewing.
- Remove both used cells and dispose according to the battery cell safety datasheet (see Section 5.4.3 for more information). Do not disassemble the battery pack any further.
- Verify that new cells are of the correct type (see above). Be sure to replace both battery cells at the same time and only use fresh (previously unused) cells.
- Place both battery cells in the battery pack, leaf contact facing the positive (+) terminal and spring contact facing the negative (-) terminal, cf. Figure 5-3.
- Assemble lid and bottom of the pack by tightening the two screws (Torx T10) with a torque of approximately 0.7 Nm. Have a firm grip around the pack until the screws are tight.
- Press the button on the pack, see Figure 5-2 (the button is located behind a hole in the pack and accessible with the tip of a pen). This will indicate to the gas detector that fresh batteries are in place and re-set the charge counter. Note that only gas detectors with firmware 3.0 or later will recognize this button operation. Please contact GasSecure should the detector in question contain an older firmware version or should you be uncertain about the firmware of this detector.

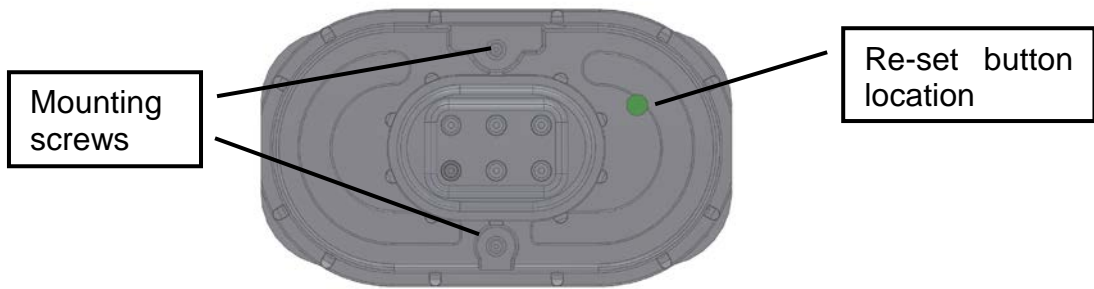

Figure 5-2: Battery pack bottom view

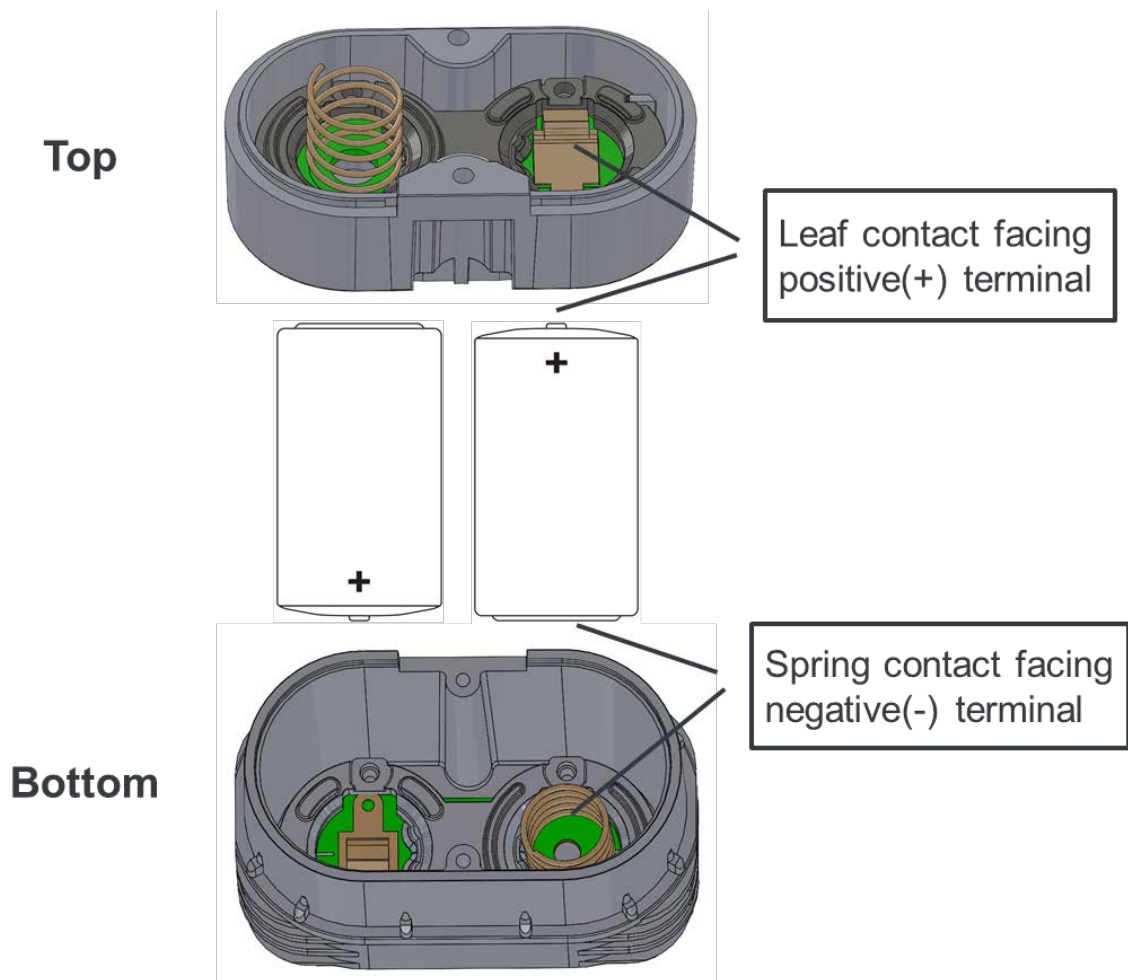

Figure 5-3: Battery pack top and bottom with leaf and spring contacts facing the battery positive (+) and negative (-) terminal, respectively.

### 5.4.3 Handling battery packs and cells

The battery pack comprises two primary lithium thionyl chloride battery cells. Under normal conditions, the battery materials are self-contained and are not reactive as long as the battery cell and pack integrity are maintained. Care should be taken to prevent thermal, electrical or mechanical damage. Protect the electrode of the battery cells to avoid short circuits. Shorted battery cells may leak fluid and produce excessive heat. Batteries should be stored in a clean and dry area. For maximum battery life, storage temperature should not exceed 25°C.



Warning. Fire, explosion, and severe burn hazard!

- Never recharge a battery pack or cell.
- Do not disassemble the battery cells.
- Do not incinerate, heat above 100°C, or expose battery packs and cells to water.

Please consult the battery cell material safety datasheet for further information.



When carried in potentially hazardous areas, the battery pack shall be kept inside an antistatic bag to avoid static charge build-up on the battery pack surface.

#### Transport

Batteries used for the GS01 detector contain lithium. Transport of primary lithium batteries is regulated by the U.S. Department of Transportation, the International Air Transport Association (IATA), the International Civil Aviation Organization (ICAO), and the European Ground Transportation of Dangerous Goods (ARD). It is the responsibility of the shipper to ensure compliance with these or any other local requirements. Consult current regulations and requirements before shipping.

#### Disposal

The battery pack is considered as hazardous waste. Please dispose of it according to laws and regulations for such waste. In the European Union directive 2006/66/EC must be respected.

### 5.5 Storage

The battery pack shall be disconnected when the detector is stored away or not in service for longer periods. The same applies when the gateway is unavailable (powered down or out of radio range). This is to avoid that the batteries are depleted. The GS01 power consumption can increase to approximately 3 times the normal average consumption when the gateway is not accessible to the device for the above-mentioned reasons.

### 5.6 Troubleshooting

Essential instrument status information is provided through the standard ISA100 Wireless object "DIAG\_STATUS" (cf. Section 3.3.1). Please refer to the Appendix for a recommended implementation of the GS01 status and diagnostic

information. The “Diag\_Status” attribute provides the information as outlined in Table 5-2.

If multiple warnings or errors occur, always clear battery warning or error first by replacing the battery pack (cf. Section 5.4.1).

For failures (mode F) not explained in Table 5-2, please clean window and mirror (cf. Section 5.3). If the failure persists, contact GasSecure.

*Table 5-2: Status messages retrieved from the Diag\_Status attribute*

<b>Instrument mode</b> (cf. Table 10-2)	<b>DIAG_STATUS bit set</b> (cf. Table 10-2)	<b>Explanation and actions</b>
M	19	Low battery. The battery must be replaced.
F and M	20	Empty battery. Replace battery immediately (see Section 5.4).
M	7	Attenuated optical beam (low optical transmission). The instrument detects low light transmission and infrared signal strength most probably due to dirty optics. Clean the window and mirror if necessary (cf. Section 5.3). The status message will clear within 10 minutes.
F and M	8	Beam block (optical beam fault). The signal is so weak that the gas concentration cannot be calculated with sufficient accuracy, or the beam intensity is changing rapidly. Check for dirty optics and clean the window and mirror (cf. Section 5.3) if necessary.
O	22	The system temperature is outside the specified operating range. For repeated high temperature warnings the use of a sunshade should be considered.
F, O, and M	22 and 8	Process value under-range. Clean the window and mirror (cf. Section 5.3). If the error persists, contact GasSecure.

## 5.7 Contact GasSecure for support

You will find our contact information and an updated list of our representatives on our homepage

**[www.gassecur.com](http://www.gassecur.com)**

When contacting the factory for support, the following information should be provided:

- The instrument serial number
- Description of the problem
- The type of gateway used for wireless communication



## 6. SAFETY INSTRUCTIONS

The GS01 detector from GasSecure is certified for and intended for use in potentially hazardous areas. Install and use the GS01 detector in accordance with the appropriate local or national regulations.

Test gases (for validation) may be toxic and/or combustible. Refer to the Material Safety Sheets for appropriate warnings.

The gas detector shall be installed and operated by trained and qualified personnel.

Warning – the GS01-EA antenna is a potential electrostatic charging hazard. The GS01-EA external antenna surface is highly resistive. Avoid electrostatic charge build-up. If necessary, only clean the unit with a damp cloth. Do not rub the antenna with non-conductive materials.

Remember to secure the GS01 detector when working at heights.

Do not open the instrument. All warranties void if opened. There are no user serviceable parts or settings inside. The manufacturer or its authorised dealers shall do any repair.

In order to maintain an FM Approved system, the apparatus to which this instrument is connected, must also be Approved by FM Approvals.

The GS01 and GS01-EA gas detectors comply with EN 60079-29-1 when connected to a control unit that also has been evaluated to EN 60079-29-1.

## 7. CERTIFICATIONS AND STANDARDS

### 7.1 Standards

The GS01 has been certified according to the ATEX Directive 2014/34/EU and is compliant with Radio Equipment Directive (RED) 2014/53/EU and the standards listed below. See also EU Declaration of Conformity in the Appendix.

*Table 7-1: List of applicable standards for the GS01*

Standard	Issue date	Title
EN 60079-0	2012	Electrical apparatus for potentially explosive atmospheres. General requirements.
EN 60079-11	2012	Electrical apparatus for potentially explosive atmospheres. Intrinsic safety "i".
IEC 60079-0	2011	Explosive atmospheres – Part 0: Equipment. General requirements.
IEC 60079-11	2011	Equipment protection by intrinsic safety "i".
EN 60079-29-1	2007	Gas detectors – Performance requirements of detectors for flammable gases.
EN 60945	2002	Maritime navigation and radio-communication equipment and systems. General requirements. Methods of testing and required test results.
EN 50270	2006	Electromagnetic compatibility. Electrical apparatus for the detection and measurement of combustible gases, toxic gases or oxygen.
EN 61000-6-3: 2007 +A1 (2011)	2011	Electromagnetic compatibility (EMC) - Part 6-3: Generic standards. Emission standard for residential, commercial and light-industrial environments.
ETSI/EN 300 328 V2.1.1	2016-11	Electromagnetic compatibility and Radio spectrum Matters (ERM).
IEC 61508 Ed. 2.0	2010-04	Functional safety of electrical, electronic, programmable electronic safety-related systems
CFR title 47 Part 15C		Code of federal regulations, telecommunications, radio frequency devices, intentional radiators

## 7.2 Regulatory compliance of radio for GS01

### 7.2.1 Radio equipment directive (RED)

The GS01 and GS01-EA wireless gas detector complies with the essential requirements and provisions of RE Directive 2014/53/EU.

### 7.2.2 FCC compliance

The GS01 and GS01-EA device complies with Part 15 of the FCC Rules. Operation is subject to the following two conditions: (1) this device may not cause harmful interference, and (2) this device must accept any interference received, including interference that may cause undesired operation.

Changes or modifications to the equipment not expressly approved by the party responsible for compliance could void the user's authority to operate the equipment.

This equipment has been tested and found to comply with the limits for a Class A digital device, pursuant to Part 15 of the FCC Rules. These limits are designed to provide reasonable protection against harmful interference when the equipment is operated in a commercial environment. This equipment generates, uses, and can radiate radio frequency energy and, if not installed and used in accordance with the instruction manual, may cause harmful interference to radio communications. Operation of this equipment in a residential area is likely to cause harmful interference in which case the user will be required to correct the interference at his own expense.

## 7.3 Marking

The GS01 and GS01-EA detectors are marked with product identification plates as shown in Figure 7-1 through Figure 7-4. The detectors are in addition marked with a label for FCC compliance (cf. Figure 7-5). The marking is explained in detail under the figures.

The antenna delivered with the GS01-EA is also marked with an identification label, cf. Figure 7-7:

<b>GasSecure, Oslo, Norway GS01</b>		
<b>CE</b>	2460	<b>Ex</b> II 2G Ex ib IIC T4 Gb
Type: GS01		-40°C < T <sub>a</sub> < +65°C
Part No: 10030		DNV 12 ATEX 10027X
Year: 20YY		IECEX DNV 12.0013X
Serial No: xx		IP 66/67
		U=7,2 V I=100mA
USE ONLY GASSECURE BATTERY PACK PART NO. 10055		

Figure 7-1: GS01 product identification plate



<b>GasSecure, Oslo, Norway GS01</b>		<b>Antenna connector:</b> $C_0 = 100 \text{ nF}$ $L_0 = 7 \text{ } \mu\text{H}$ $P_{0,DC} = 1,1 \text{ W}$ $I_0 = 1,23 \text{ A}$ $P_{0,RF} = 16 \text{ mW}$ $U_0 = 5,4\text{V}$
<b>CE</b> 2460	 II 2G   Ex ib IIC T4 Gb	
Type: GS01_EA Part No: 10190 Year: 20YY Serial No: xx	$-40^\circ\text{C} < T_a < +65^\circ\text{C}$ DNV 12 ATEX 10027X IECEx DNV 12.0013X IP 66/67 U=7,2 V I=100mA	
USE ONLY GASSECURE BATTERY PACK PART NO. 10055		

Figure 7-2: GS01-EA product identification plate



GasSecure Oslo, Norway	Type : GS01 Part no : 10030	Year: 20YY S/N : xx
<b>CE</b> 2460	 II 2G   Ex ib IIC T4 Gb  Class I, Zone 1 APPROVED Class I, Division 2	AEx ib IIC T4 Gb $-30^\circ\text{C} \leq T_a \leq +55^\circ\text{C}$ Groups A, B, C, D
ATEX : FM16ATEX0028X IEC : IECEx FMG 16.0021X	FM : FM16US0035X Power : U=7.2V, I=100mA	
ANSI/ISA 60079-29-1 IP: 66/67	IEC 60079-29-1 Gas Types: Methane / Propane	EN 60079-29-1
USE ONLY GASSECURE BATTERY PACK PART NO. 10055 CAUTION — READ AND UNDERSTAND INSTRUCTION MANUAL BEFORE OPERATING OR SERVICING.		

Figure 7-3: GS01 product identification plate – FM approved



GasSecure Oslo, Norway	Type : GS01-EA Part no : 10190	Year: 20YY S/N : xx
<b>CE</b> 2460	 II 2G   Ex ib IIC T4 Gb  Class I, Zone 1 APPROVED Class I, Division 2	AEx ib IIC T4 Gb $-30^\circ\text{C} \leq T_a \leq +55^\circ\text{C}$ Groups A, B, C, D
ATEX : FM16ATEX0028X IEC : IECEx FMG 16.0021X FM : FM16US0035X	Power : U=7.2V, I=100mA N coax : $C_0=100\text{nF}$ , $L_0=7\mu\text{H}$ , $U_0=5.4\text{V}$ $I_0=0.5\text{A}$ , $P_{0,DC}=730\text{mW}$ , $P_{0,RF}=16\text{mW}$	
ANSI/ISA 60079-29-1 IP: 66/67	IEC 60079-29-1 Gas Types: Methane / Propane	EN 60079-29-1
USE ONLY GASSECURE BATTERY PACK PART NO. 10055 CAUTION — READ AND UNDERSTAND INSTRUCTION MANUAL BEFORE OPERATING OR SERVICING.		

Figure 7-4: GS01-EA product identification plate – FM approved

The instrument marking string II 2G Ex ib IIC T4 Gb means the following:

Equipment group II

Electrical apparatus for places with an explosive gas atmosphere other than mines susceptible to firedamp.

Category 2

Equipment designed to be capable of functioning in conformity with the operating parameters established by the manufacturer and of ensuring a high level of protection. Equipment in this category is intended for use in areas in which explosive atmospheres caused by vapours, gases, mists, or air/dust mixtures are likely to occur. The means of protection relating to equipment in this category ensure the requisite level of protection even on the event of frequently occurring disturbances or equipment faults, which normally have to be taken into account.

G

The instrument is approved for use in gas, vapour, and mist atmospheres.

Ex ib

The method of protection is "intrinsic safety".

Gas group IIC

**Not** restricted to certain gases.

IP66/67

Ingress protection level (as defined in EN 60529).

Temperature class T4

The maximum surface temperature of components will not exceed 135 °C.

Gb

Equipment protection level "Gb": Equipment for explosive gas atmospheres, having a "high" level of protection, which is not a source of ignition in normal operation or during expected malfunctions.

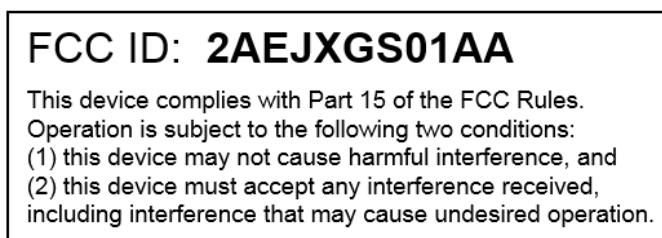

*Figure 7-5: FCC compliance label*

The GasSecure battery pack is marked with an identification label as shown in Figure 7-6 below.

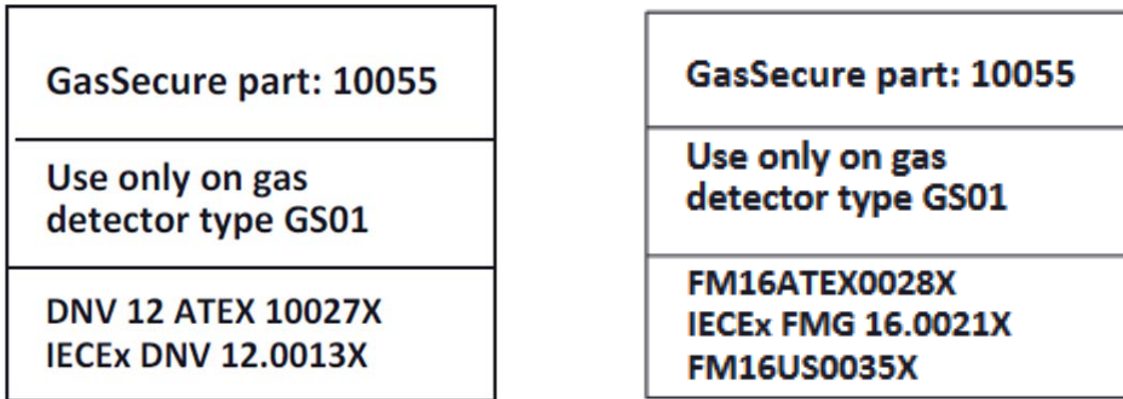

Figure 7-6: Battery pack identification label (FM approved version to the right)

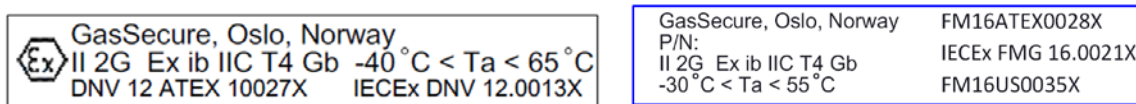

Figure 7-7: Antenna identification label (FM approved version to the right)

## 8. TECHNICAL DATA

### 8.1 Performance Characteristics

Table 8-1: Performance characteristics for the GS01

Detector Version		GS01-01A	GS01-02A
Calibration Gas		Methane	Propane
Measuring Range <sup>5</sup>		0 – 100% LEL	0-80% LEL
Internal Low Alarm Limit <sup>6</sup>		10% LEL	
Initialization time		60 s	
Response time	Default	5 s > 10% LEL	5 s > 10% LEL
	Maximum for low concentrations <sup>7</sup>	60 s < 10%LEL	60 s < 10%LEL
Accuracy <sup>8</sup>		± 3% LEL or ± 10% of reading, whichever is greater	± 2% LEL or ± 10% of reading whichever is greater. ± 20% of reading > 80% LEL.
Dead band		± 4% LEL	± 3% LEL
Battery life time <sup>9</sup>		Up to 2 years	

#### 8.1.1 Response time for other hydrocarbon gases and mixtures

Table 8-1 states response times for different concentrations of methane and propane in air. In order to achieve the default response time of 5 seconds, the speed of sound in the gas or gas mixture must be sufficiently different from this speed in air to be detected by the ultrasonic sensor (please refer to Section 1.1 for a brief introduction to the GS01 dual sensor concept). For methane and propane this occurs for concentrations above 10% LEL.

Note that, with hydrocarbon gas mixtures of light (e.g. methane) and heavy (e.g. propane) gas, the ultrasonic sensor must respond to a mixture of gases, with a speed of sound that could be close to that in air. Therefore, larger concentrations are required for mixtures of methane and propane to consistently achieve the 5 second response time. For other hydrocarbons, there will be differing concentration limits that will be required to achieve the 5 second response. Please contact GasSecure for advice of the concentration limits for other gases or gas mixtures. Note that the response time for low concentrations of hydrocarbon gas is never more than 60 seconds.

<sup>5</sup> LEL limits, please refer to Table 3-2

<sup>6</sup> Refer to Section 3.3.1 for further explanation

<sup>7</sup> Due to the limited sensitivity of the ultrasonic sensor

<sup>8</sup> Refers to operating temperature range.

<sup>9</sup> Assuming I/O device role and non-condensing environment.

## 8.2 Cross sensitivities

The GS01 is sensitive to many hydrocarbon gases, and does not distinguish one from another. In the tables below cross sensitivities to important hydrocarbon gases are presented. Please note that these are modelled estimates and shall be used as an indication only. Please contact GasSecure for cross sensitivity estimates for other gases than those listed below.

The tables are read as follows: The instrument reading is looked up in the first column. The estimated actual concentration is found in the same row in the column for the gas to be measured.

Example from Table 8-3: If a methane detector is exposed to ethanol and a value of 40 %LEL is read, the actual concentration of ethanol is approximately 15 %LEL.

### 8.2.1 GS01 detector with LEL according to IEC

All values are in % LEL. LEL values as provided in Table 8-2.

Table 8-2: LEL values in [% vol] according to IEC60079-20.

Methane	Propane	Methanol	Ethanol	Ethylene	N-butane	Hexane	Styrene	Benzene
4.4	1.7	6.0	3.1	2.3	1.4	1.0	1.0	1.2

Table 8-3: Cross sensitivities for a GS01 Methane detector.

Reading	Propane	Methanol	Ethanol	Ethylene	N-butane	Hexane	Styrene	Benzene
10	5	4	6	34	6	7	16	28
20	9	7	10	54	10	11	25	46
30	11	8	12	69	12	14	32	59
40	14	10	15	81	15	17	38	71
50	15	11	17	91	17	19	43	81
75	19	14	21	113	21	24	53	103
100	23	16	24	131	25	28	61	122

Table 8-4: Cross sensitivities for a GS01 Propane detector.

Reading	Methane	Methanol	Ethanol	Ethylene	N-butane	Hexane	Styrene	Benzene
10	24	7	11	61	11	12	28	52
20	79	14	21	116	22	25	54	106
30	159	21	31	167	33	38	77	164
40	200	27	40	>200	44	52	98	>200
50	>200	32	49	>200	55	67	117	>200
75	>200	43	69	>200	83	111	155	>200
100	>200	52	86	>200	113	167	184	>200

### 8.2.2 GS01 detector with LEL according to NIOSH

All values are in % LEL. LEL values as provided in Table 8-5.

Table 8-5: LEL values in [% vol] according to NIOSH.

Methane	Propane	Methanol	Ethanol	Ethylene	N-butane	Hexane	Styrene	Benzene
5.0	2.1	6.0	3.3	2.7	1.6	1.1	0.9	1.2

*Table 8-6: Cross sensitivities for a GS01 Methane detector.*

Reading	Propane	Methanol	Ethanol	Ethylene	N-butane	Hexane	Styrene	Benzene
10	5	5	6	31	6	7	19	31
20	8	7	10	50	9	11	30	50
30	10	9	13	63	12	14	38	64
40	12	11	15	74	14	16	45	76
50	13	12	17	83	16	19	51	87
75	17	15	21	103	20	23	62	111
100	20	17	24	119	23	28	72	132

*Table 8-7: Cross sensitivities for a GS01 Propane detector.*

Reading	Methane	Methanol	Ethanol	Ethylene	N-butane	Hexane	Styrene	Benzene
10	30	9	13	63	12	14	39	64
20	101	17	24	120	23	28	73	133
30	197	25	35	170	35	43	102	>200
40	>200	32	46	>200	47	60	128	>200
50	>200	38	55	>200	60	78	151	>200
75	>200	50	77	>200	91	135	196	>200
100	>200	60	95	>200	123	>200	>200	>200

## 9. REFERENCES

- [RD 1] Nivis ISA100.11a R2.7 Monitoring Control System User Guide Version: 1.2, Date: March 30, 2012
- [RD 2] Nivis VersaRouter 900 Hardware User Guide (VR800 Internal Hardware Rev. C) Version 1.4, Date: Mar. 18, 2010
- [RD 3] Yokogawa YFGW410 Field Wireless Management Station user's manual, IM 01W02D01-01EN
- [RD 4] Yokogawa YFGW410 Field Wireless Management Station Startup Guide, TI 01W01A56-01EN
- [RD 5] Yokogawa YFGW510 Field Wireless Access Point user's manual, IM 01W02E01-01EN
- [RD 6] Honeywell Wireless Device Manager User's Guide, Release 220, OWDOC-X254-en-220A, October 2013
- [RD 7] Honeywell Field Device Access Point User's Guide, Release 220, OWDOC-X256-en-220A, October 2013
- [RD 8] Nivis ISA100.11a Field Tool User Manual, Version 2.1, Date: October 17, 2013
- [RD 9] GasSecure GS01 wireless infrared hydrocarbon gas detector, Safety Manual, document ID 21440
- [RD 10] HUBER+SUHNER data sheet for Sencity OMNI-M Antenna: 1324.170114

10. APPENDIX

Table 10-1: PV\_Status byte description according to ISA100 Wireless™ standard

Bit 7 (MSB)	Bit 6	Bit 5	Bit 4	Bit 3	Bit 2	Bit 1	Bit 0 (LSB)
<b>Quality</b>		<b>&lt;reserved&gt;</b>	<b>Quality dependent substatus</b>			<b>Limit condition</b>	
0 = Bad (value should not be used)		This bit shall always be set to zero	0 = non-specific 1 = configuration error 2 = not connected 3 = device failure 4 = sensor failure 5 = no communication with LUV 6 = no communication no LUV 7 = out of service (value is not being computed) All other values are reserved			0 = Not limited 1 = Low limit 2 = High limit 3 = Constant (both high and low limited)	
1 = Uncertain (value of less than normal quality)			0 = non-specific 1 = last usable value 2 = substituted or manual entry 3 = initial value 4 = sensor conversion inaccurate 5 = range limits exceeded 6 = sub normal All other values are reserved				
2 = Good (quality of value is good, but an alarm condition may exist)			0 = no special conditions exist. All other values are reserved				
3 = Reserved			All values are reserved. Within this standard, this shall always be set to zero				

Table 10-2: Content of the DIAG\_STATUS attribute

(Next page)

Note also

F: Failure

C: Function check

O: Out of specification

M: Maintenance required

According to the NAMUR NE107 categorization.

GasSecure specific acronyms as used in GasSecure software tools are added in a separate column.



	Bit	DIAG_STATUS	Not supported if bit = 0	NAMUR NE107	GasSecure acronym
Standard settings	31	F: Failure Status			F
	30	C: Function check			C
	29	O: Out of specification status			O
	28	M: Maintenance required status			M
	27	Faults in electronics		F	FIE
	26	Faults in sensor or actuator element		F	FSA
	25	Installation, calibration problem		C	ICP
	24	Out of service		C	OOS
	23	Outside sensor limits	0	O	
	22	Environmental conditions, out of device spec.		O	ENC
	21	Fault Prediction: Maintenance required		M	FAP
	20	Power is critical low: maintenance short term		F M	POC
	19	Power is low: maintenance long term		M	POL
	18	Software update incomplete	0	C	
	17	Simulation is active		C	SIA
Reserved for Baseline Device Profile	16	Faults due to process influence	0	C	
	15	Faults due to non-compliance with operation conditions	0	F	
	14	Other faults		F	OTF
	13		0		
	12		0		
Vendor specific area	11		0		
	10		0		
	09		0		
	08	Optical beam fault		F M	OBF
	07	Attenuated optical beam		M	AOB
	06		0		
	05		0		
	04		0		
03		0			
02		0			
01		0			
00	Detail information available	0			

### **Recommended implementation of status and diagnostic information**

The PV\_Status byte and the gas concentration (both published in the Analog Input Object) are forwarded to the controller. The gas concentration is output as long as the status byte reads “Good” (decimal value 128) or “Uncertain” (decimal value 64 to 127). When the status byte reads “Bad” (decimal value < 64) the detector will output NaN 0x7fc00000 (not a number) per float definition in IEEE754.

The diagnostic information as published in the User Application Management Object is forwarded to the maintenance system.

Recommended is to read out the following bits of the DIAG\_STATUS attribute:

- Failure status F (bit 31)
- Maintenance required status M (bit 28).
- Environmental conditions (bit 22)
- Power is critical low (bit 20)
- Power is low (bit 19)
- Optical beam fault (bit 08)
- Attenuated optical beam (bit 07)

Refer to Table 5-2 in the troubleshooting section for description of which actions need to be taken for the different bit settings.

<p>GAS SECURE</p>		<b>Signed Document</b>	
		Document no:	1712
		Version:	6
		Date:	29/03/2017
		Pages:	1
Document name:	Declaration-Conformity GS01 2017		
Written by:	Pål Nordbryhn	Classification:	Public

## EU DECLARATION OF CONFORMITY

<b>Company:</b>	GasSecure AS
<b>Address:</b>	Hoffsveien 70C 0377 Oslo, Norway
<b>Product:</b>	GS01, Wireless hydrocarbon gas detector
<b>Part numbers:</b>	10030 (GS01 gas detector) 10190 (GS01_EA gas detector with external antenna) 10055 (battery pack)
<b>Production year:</b>	2016/2017
<b>Directives:</b>	ATEX Directive 2014/34/EU Radio Equipment Directive 2014/53/EU
<b>Product marking:</b>	 II 2G Ex ib IIC T4 Gb
<b>EC-type Examination Certificate Number:</b>	DNV 12 ATEX 10027X
<b>Notified Body</b>	DNV Nemko Presafe AS (Notified Body number 2460) Veritasveien 3 1363 Høvik, Norway
<b>Based on standards:</b>	EN 60079-0: 2012 EN 60079-11: 2012 IEC 60079-29-1: 2007 EN 60945: 2002 EN 50270: 2006 EN 61000-6-3: 2007 +A1 (2011) ETSI/EN 300328 V2.1.1 (2016-11) EN 301 489-17:V2.2.1

-----

**Declaration:**

I, the undersigned, hereby declare under my sole responsibility that the equipment specified above conforms to the above mentioned Directives and Standards.

Signature: 	Place: Oslo	Date: 29. Mar. 2017
Name: Knut Sandven	Title: CEO	

Figure 10-1: EU Declaration of conformity for GS01 and GS01-EA