



# Use and Care & Installation Guide

## Self-Cleaning Electric Range



Safety Instructions .....	3-5
Anti-Tip Device .....	3, 26, 28



Operating Instructions, Tips	
Aluminum Foil.....	4, 18,23
Automatic Timer and Clock .....	10
Canning Tips .....	9
Features .....	6,7
Oven.....	11-21
Baking .....	12-15
Broiling, Broiling Guide . . .	18,19
Control Settings . . . . .	11
Light; Bulb Replacement . . . . .	11,25
Roasting, Roasting Guide..	16, 17
Self-Cleaning Instructions .....	20,21
Thermostat Adjustment..	12
Surface Cooking.....	8,9
Control Settings .....	8
Cookware Tips . . . . .	8,9



Care and Cleaning .....	22-25
Calrod® Surface Units . . .	22
Door Removal . . . . .	25
Drip Pans .....	23
Oven Vent . . . . .	23
Storage Drawer.....	24



Problem Solver . . . . .	29,30
More questions?...call	
<b>GE Answer Center® 800.626.2000</b>	



Installation .....	26-28
Anti-Tip Device .....	3, 26,28
Flooring Under the Range .....	27
Leveling.....	28



Consumer Services .....	31
Appliance Registration....	2
Model and Serial Number Location.....	2
Warranty . . . . .	Back Cover

Models: *JBP22GR JBP26AR*  
*JBP22R JBP26GR*  
*JBP24GR JBP26WR*  
*JBP25GR JBP27GR*  
*JBP28GR*



## HELP US HELP YOU...

### Read this book carefully.

It is intended to help you operate and maintain your new range properly.

Keep it handy for answers to your questions.

If you don't understand something or need more help, write (include your phone number):

Consumer Affairs  
GE Appliances  
Appliance Park  
Louisville, KY 40225

### Write down the model and serial numbers.

Depending on your range, you'll find the model and serial numbers on a label behind the range door or behind the storage drawer.

These numbers are also on the Consumer Product Ownership Registration Card that came with your range. Before sending in this card, please write these numbers here:

\_\_\_\_\_

Model Number

\_\_\_\_\_

Serial Number

**Use** these numbers in any correspondence or service calls concerning your range.

### If you received a damaged range...

Immediately contact the dealer (or builder) that sold you the range.

### Save time and money. Before you request service...

Check the Problem Solver in the back of this book. It lists causes of minor operating problems that you can correct yourself.

---

## IF YOU NEED SERVICE...

To obtain service, see the Consumer Services page in the back of this book.

We're proud of our service and want you to be pleased. If for some reason you are not happy with the service you receive, here are three steps to follow for further help.

**FIRST.** contact the people who serviced your appliance. Explain why you are not pleased. In most cases, this will solve the problem.

**NEXT,** if you are still not pleased, write all the details—including your phone number-to:

Manager, Consumer Relations  
GE Appliances  
Appliance Park  
Louisville, KY 40225

**FINALLY,** if your problem is still not resolved, write:

Major Appliance Consumer  
Action Panel  
20 North Wacker Drive  
Chicago, IL 60606

# IMPORTANT SAFETY INSTRUCTIONS

Read all instructions before using this appliance.



## IMPORTANT SAFETY NOTICE

The California Safe Drinking Water and Toxic Enforcement Act requires the Governor of California to publish a list of substances known to the state to cause cancer, birth defects or other reproductive harm, and requires businesses to warn customers of potential exposure to such substances. The fiberglass insulation in self-clean ovens gives off a very small amount of carbon monoxide during the cleaning cycle. Exposure can be minimized by venting with an open window or using a ventilation fan or hood.

When using electrical appliances, basic safety precautions should be followed, including the following:

- Use **this appliance** only for its intended **use** as described in this manual.
- Be **sure your** appliance is properly **installed** and grounded by a qualified technician in accordance with the provided installation instructions.
- **Don't attempt** to repair or replace any part of your range unless it is specifically recommended in this book. All other servicing should be referred to a qualified technician.
- **Before performing** any service, **DISCONNECT THE RANGE POWER SUPPLY AT THE HOUSEHOLD DISTRIBUTION PANEL BY REMOVING THE FUSE OR SWITCHING OFF THE CIRCUIT BREAKER.**

**WARNING—AU** ranges can tip, and injury could result. To prevent accidental tipping of the range, attach it to the wall and floor by installing the Anti-Tip device supplied. (See Installation Instructions.) To check if the device is installed and engaged properly, carefully tip the range forward until it engages the device.

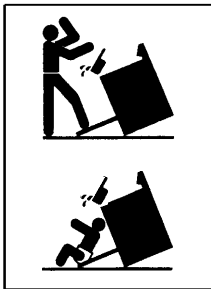

If you pull the range out from the wall for any reason, make sure the device engages the range when you push the range back.

- Do not leave children alone—children should not be left alone or unattended in an area where an appliance is in use. They should never be allowed to sit or stand on any part of the appliance.
- Don't allow anyone to climb, stand or hang on the door, drawer or cooktop. They could damage the range and even tip it over, causing severe personal injury.
- **CAUTION: ITEMS OF INTEREST TO CHILDREN SHOULD NOT BE STORED IN CABINETS ABOVE A RANGE OR ON THE BACKSPASH OF A RANGE—CHILDREN CLIMBING ON THE RANGE TO REACH ITEMS COULD BE SERIOUSLY INJURED.**
- Do not store flammable materials in an oven or near the cooktop.
- Never wear loose-fitting or hanging garments while using the appliance. Flammable material could be ignited if brought in contact with hot heating elements and may cause severe burns.
- Use only dry pot holders—moist or damp pot holders on hot surfaces may result in burns from steam. Do not let pot holders touch hot heating elements. Do not use a towel or other bulky cloth.
- For your safety, never use your appliance for warming or heating the room.
- **DO NOT STORE OR USE COMBUSTIBLE MATERIALS, GASOLINE OR OTHER FLAMMABLE VAPORS AND LIQUIDS IN THE VICINITY OF THIS OR ANY OTHER APPLIANCE.**

- Keep hood and grease filters clean to maintain good venting and to avoid grease fires.
- Do not let cooking grease or other flammable materials accumulate in or near the range.
- Do not use water on grease fires. Never pick up a flaming pan. Smother flaming pan on surface unit by covering pan completely with well-fitting lid, cookie sheet or flat tray, or if available, use dry chemical or foam-type extinguisher. Flaming grease outside a pan can be put out by covering with baking soda or, if available, a multi-purpose dry chemical or foam-type fire extinguisher.

(continued next page)



# IMPORTANT SAFETY INSTRUCTIONS

(continued)

- Do not touch heating elements or interior surface of oven. These surfaces may be hot enough to burn even though they are dark in color. During and after use, do not touch, or let clothing or other flammable materials contact surface units, areas nearby surface units or any interior area of the oven; allow sufficient time for cooling, first.

Potentially hot surfaces include the cooktop, areas facing the cooktop, oven vent opening, surfaces near the opening, crevices around the oven door and metal trim parts above the door. Remember: The inside surface of the oven may be hot when the door is opened.

- When cooking pork, follow the directions exactly and always cook the meat to an internal temperature of at least 170°F. This assures that, in the remote possibility that trichina may be present in the meat, it will be killed and the meat will be safe to eat.

---

## Oven

- Stand away from range when opening oven door. Hot air or steam which escapes can cause burns to hands, face and/or eyes.
- **Don't** heat unopened food containers in the oven. Pressure could build up and the container could burst, causing an injury.



- Keep oven vent unobstructed.
- Keep oven free from grease buildup.
- Place oven shelf in desired position while oven is cool. If shelves must be handled when hot, do not let pot holder contact heating units in the oven.
- Pulling out shelf to the shelf stop is a convenience in lifting heavy foods. It is also a precaution against burns from touching hot surfaces of the door or oven walls.
- When using cooking or roasting bags in oven, follow the manufacturer's directions.
- Do not use your oven to dry newspapers. If overheated, they can catch fire.
- Do not use oven for a storage area. Items stored in an oven can ignite.
- Do not leave paper products, cooking utensils, or food in the oven when not in use.

## Self-Cleaning Oven

- Do not clean door gasket. The door gasket is essential for a good seal. Care should be taken not to rub, damage or move the gasket.
- Do not use oven cleaners. No commercial oven cleaner or oven liner protective coating of any kind should be used in or around any part of the oven.
- Clean only parts listed in this Use and Care Book.
- Before self-cleaning the oven, remove broiler pan and other cookware.
- Be sure to wipe up excess spillage before starting the Self-Clean operation.

---

## Surface Cooking Units

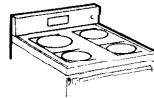

- **Use proper pan size**-This appliance is equipped with different size surface units. Select cookware having flat bottoms large enough to cover the surface unit heating element. The use of undersized cookware will expose a portion of the heating element to direct contact and may result in ignition of clothing. Proper relationship of cookware to burner will also improve efficiency.
- Never leave surface units unattended at high heat settings. Boilover causes smoking and greasy spillovers that may catch on fire.
- Be sure drip pans and vent are not covered and are in place. Their absence during cooking could damage range parts and wiring.
- **Don't** use aluminum foil to line drip pans or anywhere in the oven except as described in this book. Misuse could result in a shock, fire hazard or damage to the range.
- Only certain types of **glass, glass/ceramic, earthenware** or other glazed containers are suitable for cooktop service; others may break because of the sudden change in temperature. See section on Surface Cooking for suggestions.
- To minimize the possibility of burns, ignition of flammable materials, and spillage, the handle of a container should be turned toward the center of the range without extending over nearby surface units.



- Always turn surface unit to OFF before removing cookware.
- Keep an eye on foods being fried at HI or MEDIUM HIGH heat settings.
- To avoid the possibility of a burn or electric **shock**, always be certain that the controls for all surface units are at OFF position and all coils are cool before attempting to remove the unit.
- **Don't** immerse or soak removable surface units. **Don't** put them in a dishwasher. Do not self-clean the **surface** units in the oven.
- When flaming foods are under the hood, turn the fan off. The fan, if operating, may spread the flame.
- Foods for frying should be as dry as possible. Frost on frozen foods or moisture on fresh foods can cause hot fat to bubble up and over sides of pan.
- Use little fat for effective shallow or deep-fat frying. Filling the pan too full of fat can cause spillovers when food is added.
- If a combination of oils or fats will be used in frying, stir together before heating, or as fats melt slowly.
- Always heat fat slowly, and watch as it heats.
- Use deep fat thermometer whenever possible to prevent overheating fat beyond the smoking point.

**SAVE THESE INSTRUCTIONS**



# FEATURES OF YOUR RANGE

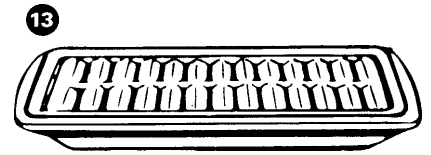
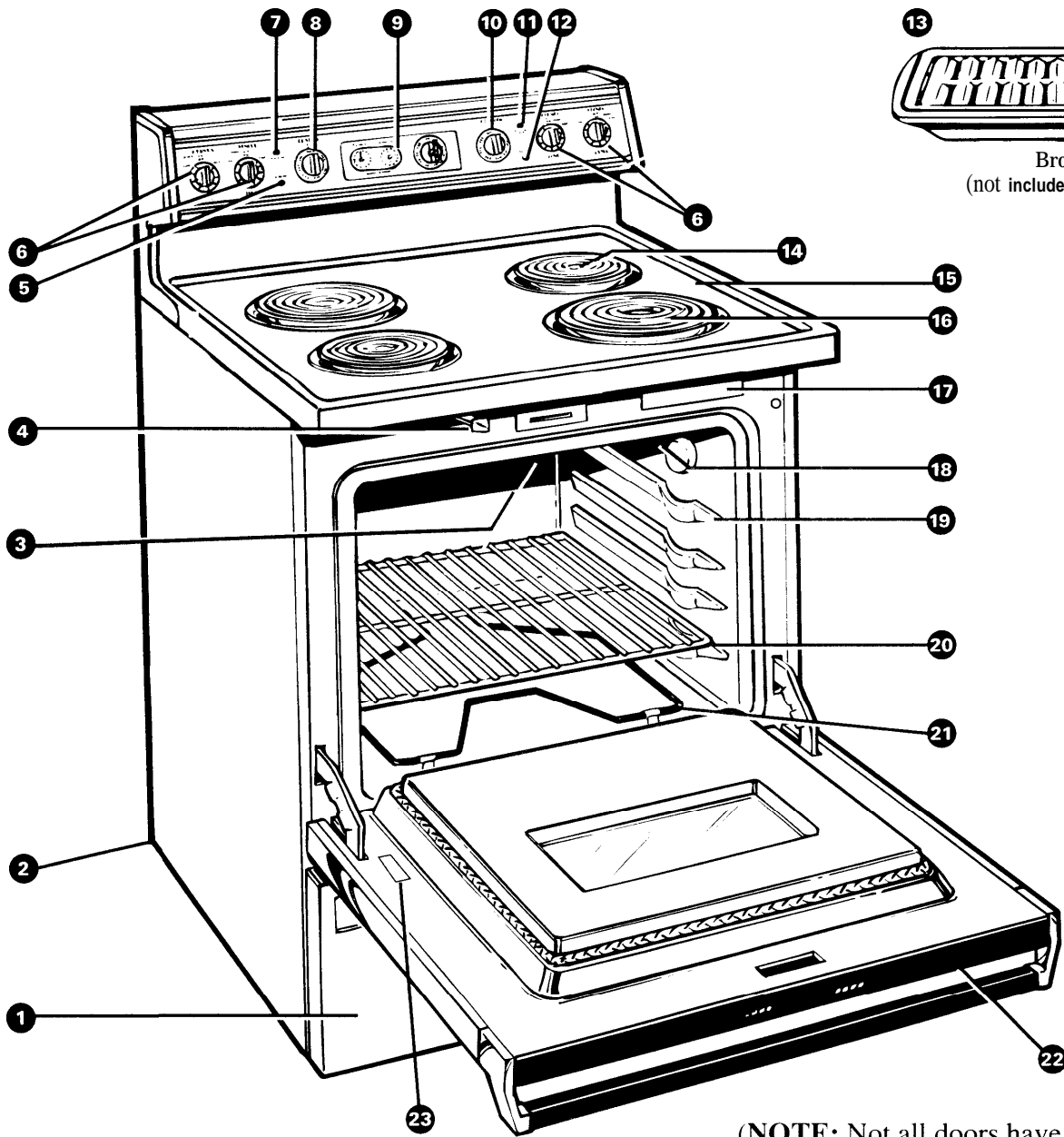

Broiler Pan  
(not included on all models)

(NOTE: Not all doors have windows.)

- JBP22GR    JBP22R
- JBP24GR    JBP25GR
- JBP26AR    JBP26GR
- JBP26WR    JBP27GR
- JBP28GR

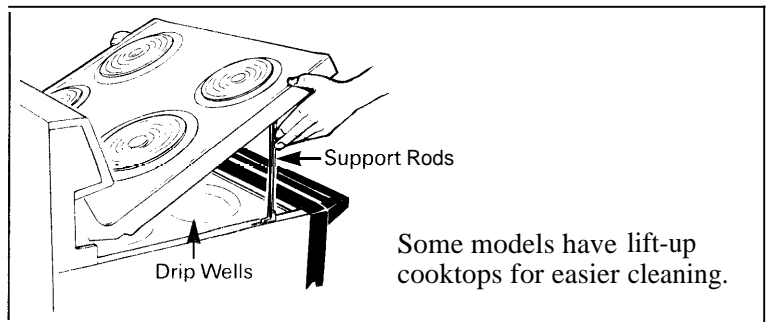



<b>Feature Index</b> (Not all models have all features. )	<b>Explained on page</b>
1 Storage Drawer (on some models)	<b>24</b>
2 Anti Tip Device (See Installation Instructions. )	<b>3,26,28</b>
3 <b>Broil</b> Unit	
4 Door Latch ( Use for Self-Clean only.)	20, 21
5 Oven Cycling <b>Light</b>	11
6 Surface Unit <b>Controls</b>	8
7 Oven "ON" Light	11
8 Oven Set control"	11, 12, 13
9 Automatic Oven Timer, Clock and Minute Timer	10
10 Oven Temp ("011 Control	11, 12, 13
11 Surface Unit "ON" Indicator Light	8
12 Oven Cleaning Light	20
13 Broiler Pan and Rack (on some models) (Do not clean in Self-Cleaning Oven.)	<b>16, 18, 19, 24</b>
14 Oven Vent (Located under the right rear surface unit. )	23
15 Lift-Up Cooktop (on some models)	<b>22</b>
<b>16</b> Calrod Surface Unit, Drip Pan\	22, 23
17 Model and Serial Number Location (behind the range door or behind the storage drawer)	2
18 Oven Interior Light (on some models) (Comes on automatically when door is opened.)	11
19 Oven Shelf Supports	11
20 Oven Shelf (Number may vary.)	11, 24
21 Bake Unit (May be lifted gently for wiping the oven floor.)	-
22 Oven Light Switch (for models with oven window)	11
23 Anti-Tip Label	



# SURFACE COOKING

At both OFF and HI the control “clicks” into position. You may hear slight “clicking” sounds during cooking, indicating the control is keeping the unit at the heat level or power level you set.

## How to Set the Controls

Push the knob in and turn in either direction to the heat setting you want.

Be sure you turn control to OFF when you finish cooking. The surface unit indicator light will glow when ANY heat on any surface unit is on.

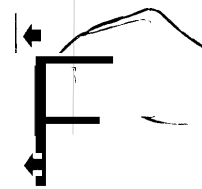

## Heat Setting Guide

**HI**—Used to begin cooking or to bring water to a boil. Reduce heat setting after water boils.

**MEDIUM HIGH**—(Setting halfway between HI and MED) Maintains a fast boil on large amounts of food.

**MED**—Saute and brown; keeps food at a medium boil or simmer.

**MEDIUM LOW**—(Setting halfway between MED and LO) Cook after starting at HI; cooks with little water in covered pan.

**LO**—Used for long slow cooking (simmering) to tenderize and develop flavors. Use this setting to melt butter and chocolate or to keep foods warm.

**NOTE:** Surface Indicator Light may glow between LO and OFF, but there is no power to the surface units.

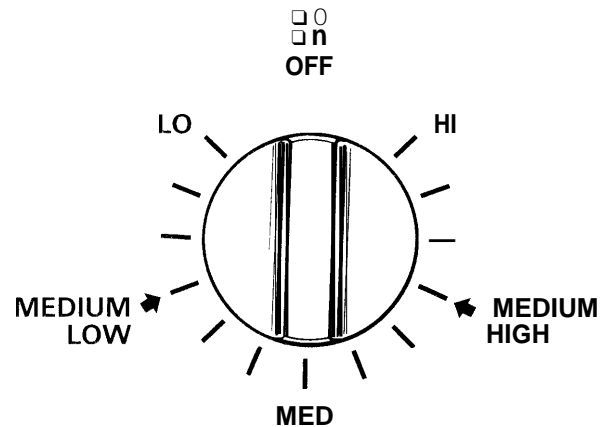

## COOKING TIPS

### Cookware

- Use medium-or heavy-weight cookware. Aluminum cookware conducts heat faster than other metals. Cast-iron and coated cast-iron cookware are slow to absorb heat, but generally cook evenly at low to medium heat settings. Steel pans may cook unevenly if not combined with other metals.
- For best cooking results pans should be flat on the bottom. Match the size of the saucepan to the size of the surface unit. The pan should not extend over the edge of the trim ring more than 1“.

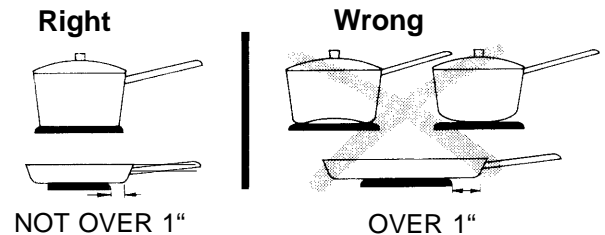





## Deep Fat Frying

- Do not overfill cookware with fat that may spill over when adding food. Frosty foods bubble vigorously. Watch food frying at high temperatures. Keep range and hood clean from grease.

## Wok Cooking

- We recommend that you use only a flat-bottomed wok. They are available at your local retail store.



- Use of these types of woks, without the support ring in place, is dangerous because the wok is unstable.
- With the ring in place, heat will be trapped inside the ring and may cause damage to the porcelain cooktop.

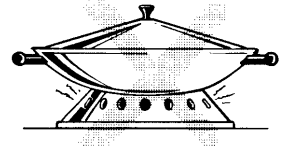

## HOME CANNING TIPS

### Canning should be done on surface units only.

Pots that extend beyond one inch of surface unit's drip pan are not recommended for most surface cooking. However, when canning with water-bath or pressure canner, larger-diameter pots may be used. This is because boiling water temperatures (even under pressure) are not harmful to cooktop surfaces surrounding the surface unit.

HOW-EVER, DO NOT USE LARGE DIAMETER CANNERS OR OTHER LARGE DIAMETER POTS FOR FRYING OR BOILING FOODS OTHER THAN WATER. Most syrup or sauce mixtures—and all types of frying—cook at temperatures much higher than boiling water. Such temperatures could eventually harm cooktop surfaces surrounding surface units.

### Observe the Following Points in Canning

1. Be sure the canner fits over the center of the surface unit. If your range or its location does not allow the canner to be centered on the surface unit, use smaller-diameter pots for good canning results.
2. For best results, use canners with flat bottoms. Canners with flanged or rippled bottoms (often found in enamelware) don't make good contact with the surface unit and take a long time to boil water.
3. When canning, use recipes and procedures from reputable sources. Reliable recipes and procedures are available from the manufacturer of your canner; manufacturers of glass jars for canning, such as Ball and Kerr; and the United States Department of Agriculture Extension Service.
4. Remember that canning is a process that generates large amounts of steam. To avoid burns from steam or heat, be careful when canning.



**Flat-bottomed canners are recommended.**

**NOTE:** If your house has low voltage, canning may take longer than expected, even though directions have been carefully followed.

The process time will be shortened by:

- (1) using a pressure canner, and
- (2) starting with **HOT** tap water for fastest heating of large quantities of water.

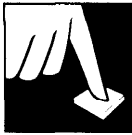

# AUTOMATIC TIMER AND CLOCK

The automatic timer and clock on your range are helpful devices that serve several purposes.

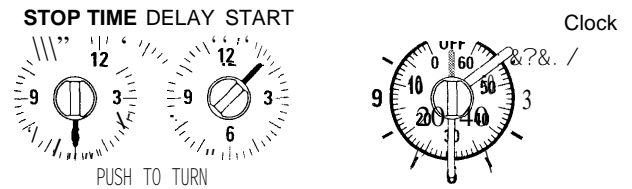

## To Set the Clock

To set the Clock, **push the knob in** and turn the clock hands to the correct time. (The Minute Timer pointer will move also. Let the knob out, then turn the Minute Timer pointer to OFF. )

## Minute Timer

The Minute Timer has been combined with the CLOCK. Use it to time all your precise cooking operations. You'll recognize the Minute Timer as the pointer which is different in color and shape than the clock hands.

## To Set the Minute Timer

To set the Minute Timer, turn the center knob, **without pushing in**, until pointer reaches number of minutes **you** wish to time. (Minutes are marked, up to 60, in the center ring on the clock.) At the end of the set time, a buzzer sounds to tell you time is up. Turn knob, **without pushing in**, until pointer reaches OFF and buzzer stops.

## Questions and Answers

**Q. Must the clock be set on correct time of day when I wish to use the Automatic Timer for baking?**

**A. Yes**, if you wish to set the DELAY START or STOP TIME dials (on some models) to turn on and off at set times during timed functions.

**Q. Can I use the Minute Timer during oven cooking?**

**A. The Minute Timer can be used during any cooking function.** The Automatic Timers (DELAY START and STOP TIME dials) are used with TIMED BAKED function only.

**Q. Should I change the clock while I'm Time Cooking in the oven?**

**A. The clock should not be changed during any program that uses the oven timer.** You must either stop those programs or wait until they are finished before changing time.

# USING YOUR OVEN

Do not lock the oven door with the door latch except when self-cleaning.



## Before Using Your Oven

1. Look at the controls. Be sure you understand how to set them properly. Read over the directions for the Automatic Oven Timer so you understand its use with the controls.
2. Check oven interior. Look at the shelves. Take a practice run at removing and replacing them properly to give sure, sturdy support.
3. Read over information and tips that follow.
4. Keep this book handy so you can refer to it, especially during the first weeks of using your new range.

## Oven Controls

Some models have one oven control knob—OVEN TEMP. Other models have two oven control knobs—OVEN TEMP and OVEN SET.

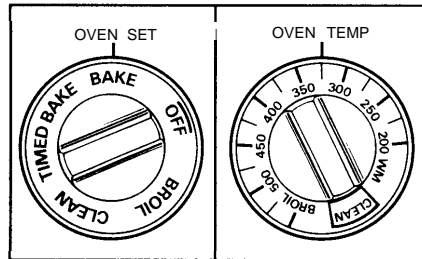

The OVEN SET knob has settings for BAKE, TIMED BAKE, BROIL and OFF.

OVEN TEMP control maintains the temperature you set, from WARM (150°F.) to BROIL (550°F.) and also at CLEAN (880°F.). On some models, the OVEN TEMP knob also turns the oven OFF.

**The Oven Cycling Light** glows until the oven reaches your selected temperature, then goes off and on with the oven unit(s) during cooking.

PREHEATING the oven, even to high temperature settings, is speedy. It rarely takes longer than 10 minutes. Preheat the oven only when necessary. Most foods will cook satisfactorily without preheating. If you find preheating is necessary, keep an eye on the indicator light and put food in the oven promptly after light goes out.

**The Oven On Light** will glow any time the OVEN SET knob is not in the OFF position.

## Oven Light (on some models)

The light comes on automatically when the door is opened. (On models with oven window, use switch to turn light on and off when door is closed.)

Switch is located on the front of the door.

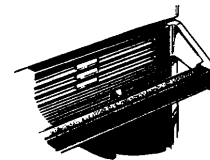

## Oven Interior Shelves

The shelves are designed with stop-locks, so that when placed correctly on the shelf supports, they will stop before coming completely out from the oven, and will not tilt when removing food from or placing food on them.

### TO REMOVE THE SHELVES

from the oven, pull the shelf toward you, tilt front end upward and pull the shelf out.

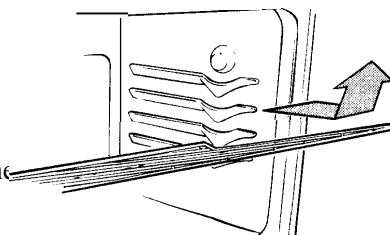

**TO REPLACE**, place the shelf on shelf support with stop-locks (curved extension under shelf) facing up and toward the rear of the oven. Tilt up front and push shelf toward the back of the oven until it goes past "stop" on the oven wall. Then lower the front of the shelf and push it all the way back.

The oven has four shelf supports identified in this illustration as A (bottom), B, C and D (top).

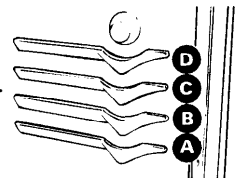

(continued next page)



# USING YOUR OVEN

(continued)

## Adjusting Oven Thermostat

Use the time given in your recipe when using the oven for the first time. Oven thermostats, in time, may “drift” from the factory setting and differences in timing between an old and a new oven of 5 to 10 minutes are not unusual. Your oven has been set correctly at the factory and is more likely to be accurate than the oven which it replaced. However, if you find that your foods consistently brown too little or too much, you may make a simple adjustment in the thermostat (Oven Temp) knob.

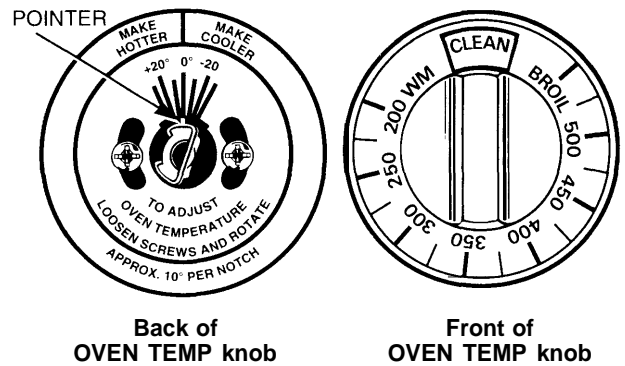

Back of  
OVEN TEMP knob

Front of  
OVEN TEMP knob

### To adjust the thermostat knob:

1. Pull the knob off the shaft, look at the back of the knob and note the current setting before making any adjustments.
2. Loosen both screws on the back of the knob.
3. If the oven temperature seems too hot, move the pointer toward the words MAKE COOLER. If the temperature seems too cool, move the pointer toward the words MAKE HOTTER. Each notch will change the oven temperature about 10 degrees Fahrenheit.
4. Tighten the screws.
5. Replace the knob, matching the flat area of the knob to the shaft.

## BAKING

### How to Set Your Range for Baking

1. To avoid possible burns, place the oven shelves in the correct position before you turn the oven on.
2. Close the oven door.
3. Turn the OVEN SET knob to BAKE and the OVEN TEMP knob to the temperature you desire.
4. Turn the OVEN SET knob to OFF when baking is finished.

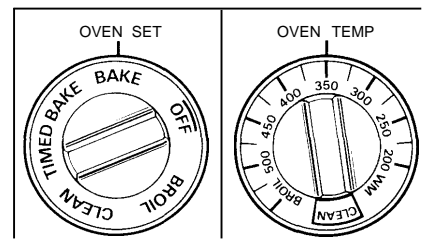

# TIMED BAKING

(on some models)



The automatic oven timer controls are designed to turn the oven on or off automatically at specific times that you set. (Use TIMED BAKE on the OVEN SET knob.)

## How to Set Immediate Start and Automatic Stop

**NOTE:** Before beginning, make sure the hands of the range clock show the correct time of day.

To start cooking immediately and turn off automatically, you must turn the OVEN SET knob to TIMED BAKE. Remember, foods continue cooking after controls are off because the oven retains heat for a long time, if the oven door is not opened.

1. To set Stop Time, push in

TIME dial and turn pointer to time-you want

oven to turn off; for example 6:00. The DELAY START dial should be at the same position as the time of day on clock.

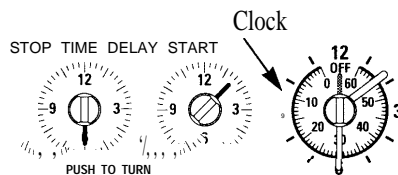

2. Turn OVEN SET knob to TIMED BAKE. Turn OVEN TEMP knob to oven temperature, for example 250°F. The oven will start immediately and will stop at the time you have set.

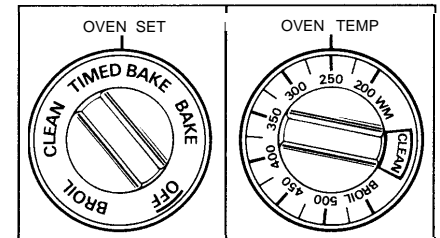

Foods that are highly perishable, such as milk, eggs, fish, stuffings, poultry and pork should not be allowed to sit out for more than one hour before or after cooking. Room temperature promotes the growth of harmful bacteria.

## How to Set Delay Start and Stop

Delay Start and Stop is setting the oven timer to turn the oven on and off automatically at a later time than the present time of day. You must use the TIMED BAKE setting.

1. To set start time, push in knob on DELAY START dial and turn

pointer to time you want oven to turn on, for example 3:30.

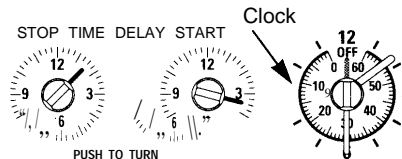

2. To set Stop Time, push in knob on TIME dial and turn pointer to

time-you want oven to turn off, for example 6:00. This means your recipe called for two and one-half hours of baking time.



Foods that are highly perishable, such as milk, eggs, fish, stuffings, poultry and pork should not be allowed to sit out for more than one hour before or after cooking. Room temperature promotes the growth of harmful bacteria.

**NOTE:**

- Be sure that oven light is off because heat from the bulb will speed harmful bacteria growth.
- The time on STOP TIME dial must be later than the time shown on range clock and DELAY START dial.

3. Turn OVEN SET knob to TIMED BAKE. Turn OVEN TEMP knob to 250°F. or recommended temperature.

Place food in oven, close the door and automatically the oven will be turned on and off at the times you have set. When cooking is completed, turn OVEN SET to OFF and remove food from oven.

OVEN INDICATOR LIGHT(S) at TIMED BAKE setting may work differently than they do at BAKE setting. Carefully recheck the steps given above. If all operations are done as explained, oven will operate as it should.

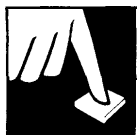

# BAKING

(continued)

For best baking results, follow these suggestions:

## Oven Shelves

Arrange the oven shelf or shelves in the desired locations while the oven is cool. The correct shelf position depends on the kind of food and the browning desired.

As a general rule, place most foods in the middle of the oven, on either the second or third shelf from the bottom. See the chart for suggested shelf positions.

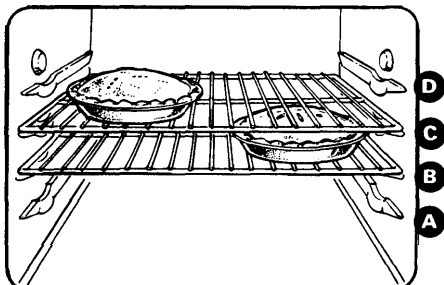

Type of Food	Shelf Position
Angel food cake	A
Biscuits or muffins	B or C
Cookies or cupcakes	B or C
Brownies	B or C
Layer cakes	B or C
Bundt or pound cakes	A or B
Pies or pie shells	B or C
Frozen pies	A (on cookie sheet)
Casseroles	B or C
Roasting	A or B

## Preheating

Preheat the oven if the recipe calls for it. Preheat means bringing the oven up to the specified temperature before putting in the food. To preheat, set the oven at the correct temperature—selecting a higher temperature does not shorten preheat time.

Preheating is necessary for good results when baking cakes, cookies, pastry and breads. For most casseroles and roasts, preheating is not necessary. For ovens without a preheat indicator light or tone, preheat 10 minutes. After the oven is preheated place the food in the oven as quickly as possible to prevent heat from escaping.

## Baking Pans

Use the proper baking pan. The type of finish on the pan determines the amount of browning that will occur.

- Dark, rough or dull pans absorb heat resulting in a browner, crisper crust. Use this type for pies.
- Shiny, bright and smooth pans reflect heat, resulting in a lighter, more delicate browning. Cakes and cookies require this type of pan.
- Glass baking dishes also absorb heat. When baking in glass baking dishes, lower the temperature by 25°F. and use the recommended cooking time in the recipe. This is not necessary when baking pies or casseroles.

## Pan Placement

For even cooking and proper browning, there must be enough room for air circulation in the oven. Baking results will be better if baking pans are centered as much as possible rather than being placed to the front or to the back of the oven.

Pans should not touch each other or the walls of the oven. Allow 1 to 1 ½ inch space between pans as well as from the back of the oven, the door and the sides. If you use two shelves, stagger the pans so one is not directly above the other.



## Baking Guides

When using prepared baking mixes, follow package recipe or instructions for best results.

### Cookies

When baking cookies, flat cookie sheets (without sides) produce better-looking cookies. Cookies baked in a jelly roll pan (short sides all around) may have darker edges and pale or light browning may occur.

Do not use a cookie sheet so large that it touches the walls or the door of the oven.

For best results, use only one cookie sheet in the oven at a time.

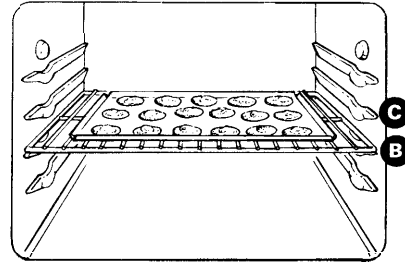

### Pies

For best results, bake pies in dark, rough or dull pans to produce a browner, crisper crust. Frozen pies in foil pans should be placed on an aluminum cookie sheet for baking since the shiny foil pan reflects heat away from the pie crust; the cookie sheet helps retain it.

### Cakes

When baking cakes, warped or bent pans will cause uneven baking results and poorly shaped products. A cake baked in a pan larger than the recipe recommends will usually be crisper, thinner and drier than it should be. If baked in a pan smaller than recommended, it may be undercooked and batter may overflow. Check the recipe to make sure the pan size used is the one recommended.

### Aluminum Foil

Never entirely cover a shelf with a large cookie sheet or aluminum foil. This will disturb the heat circulation and results in poor baking. A smaller sheet of foil may be used to catch a spillover by placing it on a lower shelf several inches below the food.

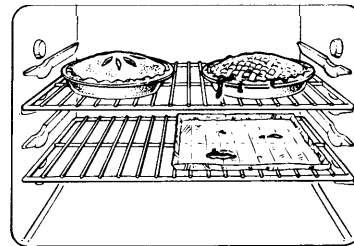

### Don't Peek

Set the timer for the estimated cooking time and do not open the door to look at your food. Most recipes provide minimum and maximum baking times such as "bake 30-40 minutes."

**DO NOT** open the door to check until the minimum time. Opening the oven door frequently during cooking allows heat to escape and makes baking times longer. Your baking results may also be affected.



# ROASTING

Roasting is cooking by dry heat. Tender meat or poultry can be roasted uncovered in your oven. Roasting temperatures, which should be low and steady, keep spattering to a minimum.

Roasting is really a baking procedure used for meats. Therefore, oven controls are set to BAKE or TIMED BAKE. (You may hear a slight clicking sound, indicating the oven is working properly. ) Roasting is easy; just follow these steps:

1. Place the shelf in A or B Position. No preheating is necessary.

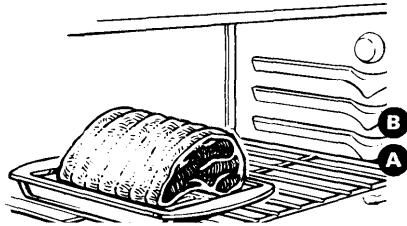

2. Check the weight of the meat. Place the meat fat-side-up, or poultry breast-side-up, on roasting rack in a shallow pan. The melting fat will baste the meat. Select a pan as close to the size of the meat as possible. (Broiler pan with rack is a good pan for this. ) Line broiler pan with aluminum foil when using pan for marinating, cooking with fruits, cooking heavily cured meats, or basting food during cooking. Avoid spilling these materials inside the oven or inside the oven door.
3. Turn OVEN SET (on some models) to BAKE and OVEN TEMP to 325°F. Small poultry may be cooked at 375°F. for best browning.

4. Most meats continue to cook slightly while standing, after being removed from the oven. Standing time recommended

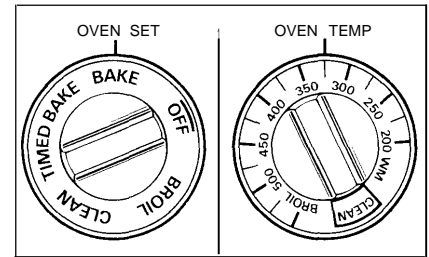

for roasts is 10 to 20 minutes. This allows roasts to firm up and makes them easier to carve. Internal temperature will rise about 5° to 10°F.; to compensate for temperature increase, if desired, remove roast from oven sooner (at 5° to 10°F. less than temperature in the guide).

## NOTE:

- You may wish to use TIMED BAKE, as described in the Baking section of this book, to turn oven on and off automatically.
- Remember that food will continue to cook in the hot oven and therefore should be removed when the desired internal temperature has been reached.

## Frozen Roasts

- Frozen roasts of beef, pork, lamb, etc., can be started without thawing, but allow 10 to 25 minutes per pound additional time (10 minutes per pound for roasts under 5 pounds, more time for larger roasts).
- Thaw most frozen poultry before roasting to ensure even doneness. Some commercial frozen poultry can be cooked successfully without thawing. Follow directions given on package label.





## Questions and Answers

**Q. Is it necessary to check for doneness with a meat thermometer?**

**A.** Checking the finished internal temperature at the completion of cooking time is recommended. Temperatures are shown in Roasting Guide. For roasts over 8 lbs., check with thermometer at half-hour intervals after half the time has passed.

**Q. Why is my roast crumbling when I try to carve it?**

**A.** Roasts are easier to slice if allowed to cool 10 to 20 minutes after removing from oven. Be sure to cut across the grain of the meat.

**Q. Do I need to preheat my oven each time I cook a roast or poultry?**

**A.** It is unnecessary to preheat your oven.

**Q. When buying a roast, are there any special tips that would help me cook it more evenly?**

**A. Yes.** Buy a roast as even in thickness as possible, or buy rolled roasts.

**Q. Can I seal the sides of my foil “tent” when roasting a turkey?**

**A.** Sealing the foil will steam the meat. Leaving it unsealed allows the air to circulate and brown the meat.

## ROASTING GUIDE

Type	Oven Temperature	Doneness	Approximate Roasting Time in Minutes per Pound		Internal Temperature °F.
<b>Meat</b> Tender cuts; rib, high quality sirloin tip, rump or top round†	<b>325°</b>	Rare: Medium: Well Done:	<b>3 to 5 lbs.</b> 24-30 30-35 35-45	<b>6 to 8 lbs.</b> 18-25 22-25 28-33	140°-150°* 150°- 160° 170°-1 85°
Lamb leg or bone-in shoulder†	<b>325°</b>	Rare: Medium: Well Done:	21-25 25-30 30-35	20-23 24-28 28-33	140°-150°* 150°- 160° 170°- 185°
Veal shoulder, leg or loin†	<b>325°</b>	Well Done:	35-45	30-40	1700- 180°
Pork loin, rib or shoulder†	<b>325°</b>	Well Done:	35-45	30-40	170°- 180°
Ham, precooked	<b>325°</b>	To Warm:	10 minutes per pound (any weight)		125°- 130°
<b>Poultry</b> Chicken or Duck Chicken pieces	<b>325°</b> <b>350°</b>	Well Done: Well Done:	<b>3 to 5 lbs.</b> 35-40 35-40	<b>Over 5 lbs.</b> 30-35	185°- 1 90° 185°- 190°
Turkey	<b>325°</b>	Well Done:	<b>10 to 15 lbs.</b> 20-25	<b>Over 15 lbs.</b> 15-20	<b>In thigh:</b> 185°- 190°

†For boneless rolled roasts over 6 inches thick, add 5 to 10 minutes per pound to times given above.

\*The U.S. Department of Agriculture says “Rare beef is popular, but you should know that cooking it to only 140°F. means some food poisoning organisms may survive.” (Source: Safe Food Book. Your Kitchen Guide. USDA Rev. June 1985. )



# BROILING

Broiling is cooking food by intense radiant heat from the upper unit in the oven. Most fish and tender cuts of meat can be broiled. Follow these steps to keep spattering and smoking to a minimum.

1. If meat has fat or gristle near edge, cut vertical slashes through both about 2" apart. If desired, fat may be trimmed, leaving layer about 1/8" thick.
2. Place meat on broiler rack in broiler pan. Always use rack so fat drips into broiler pan; otherwise juices may become hot enough to catch fire.
3. Position shelf on recommended shelf position as suggested in Broiling Guide. Most broiling is done on C position, but if your range is connected to 208 Volts, you may wish to use a higher position.
4. Leave door ajar a few inches. The door stays open by itself, yet the proper temperature is maintained in the oven.

5. Turn OVEN SET (on some models) and OVEN TEMP knob to BROIL. Preheating units is not necessary. (See notes in Broiling Guide. )

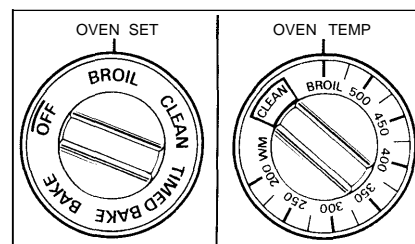

6. Turn food only once during broiling. Time foods for first side per Broiling Guide.

Turn food, then use times given for second side as a guide to preferred doneness. (Where two thicknesses and times are given together, use first times given for thinnest food. )

7. When finished broiling, turn OVEN SET or OVEN TEMP knob to OFF (depending on your model). Serve food immediately, leaving the broiler pan and rack outside oven to cool during meal for easiest cleaning.

## Use of Aluminum Foil

You can use aluminum foil to line your broiler pan and broiler rack. However, you must mold the foil tightly to the rack and cut slits in it just like the rack.

Without the slits, the foil will prevent fat and meat juices from draining to the broiler pan. The juices could become hot enough to catch on fire. If you do not cut the slits, you are frying, not broiling.

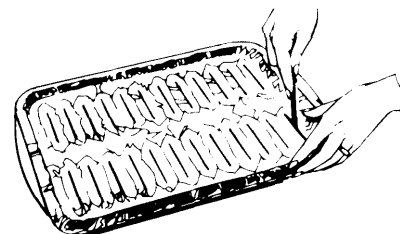

## Questions & Answers

**Q. When broiling, is it necessary to always use a rack in the pan?**

**A. Yes.** Using the rack suspends the meat over the pan. As the meat cooks, the juices fall into the pan, thus keeping meat drier. Juices are protected by the rack and stay cooler, thus preventing excessive spatter and smoking.

**Q. Should I salt the meat before broiling?**

**A. No.** Salt draws out the juices and allows them to evaporate. Always salt after cooking. Turn meat with tongs; piercing meat with a fork allows juices to escape. When broiling poultry or fish, brush each side often with butter.

**Q. Why are my meats not turning out as brown as they should?**

**A.** In some areas, the power (voltage) to the oven may be low. In these cases, preheat the broil unit for 10 minutes before placing broiler pan with food in oven. Check to see if you are using the recommended shelf position. Broil for longest period of time indicated in the Broiling Guide. Turn food only once during broiling.

**Q. Do I need to grease my broiler rack to prevent meat from sticking?**

**A. No.** The broiler rack is designed to reflect broiler heat, thus keeping the surface COOI enough to prevent meat from sticking to the surface. However, spraying the broiler rack lightly with a vegetable cooking spray before cooking will make cleanup easier.

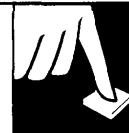

1. Always use broiler pan and rack that comes with your oven. It is designed to minimize smoking and spattering by trapping juices in the shielded lower part of the pan.
2. Oven door should be open to broil stop position.
3. For steaks and chops, slash fat evenly around outside edges of meat. To slash, cut crosswise through outer fat surface just to the edge of the meat. Use tongs to turn meat over to prevent piercing meat and losing juices.
4. If desired, marinate meats or chicken before broiling, or brush with barbecue sauce last 5 to 10 minutes only.
5. When arranging food on pan, do not let fatty edges hang over sides, which could soil oven with fat dripping.
6. Broiler does not need to be preheated. However, for very thin foods, or to increase browning, preheat if desired.
7. Frozen steaks can be broiled by positioning the oven shelf at next lowest shelf position and increasing cooking time given in this guide 1 ½ times per side.
8. If your range is connected to 208 Volts, rare steaks may be broiled by preheating the broiler and positioning the oven shelf one position higher.

## BROILING GUIDE

Food	Quantity and/or Thickness	Shelf Position	First Side Time, Minutes	Second Side Time, Minutes	Comments
Bacon	1/2 lb. (about 8 thin slices)	c	3½	3½	Arrange in single layer.
Ground Beef Well Done	1 lb. (4 patties) 1/2 to 3/4 inch thick	c	7	4-5	Space evenly. Up to 8 Patties take about same time.
Beef Steaks	1 inch thick (1 to 1½ lbs.)	<b>C</b>	7	7	Steaks less than 1 inch thick cook through before browning. Pan frying is recommended. Slash fat.
Medium Well Done		<b>C</b>	9	9	
Rare	1½ inch thick (2 to 2½ lbs.)	<b>C</b>	10	7-8	
Medium Well Done		<b>C</b>	15	14-16	
Well Done		<b>C</b>	25	20-25	
Chicken	<b>1 whole</b> (2 to 2½ lbs.), split lengthwise	A	35	10-15	Reduce time about 5 to 10 minutes per side for cut-up chicken. Brush each side with melted butter. Broil skin-side-down first.
Bakery Products	2 to 4 slices	c	1½-2	1/2	Space evenly. Place English muffins cut-side-up and brush with butter, if desired.
Bread (Toast) or Toaster Pastries	1 pkg. (2)	c	3-4		
English Muffins	2 (split)	c			
Lobster Tails	2-4 (6 to 8 oz. each)	B	13-16	Do not turn over.	Cut through back of shell. Spread open. Brush with melted butter before and after half of broiling time.
Fish	1-lb. fillets 1/4 to 1/2 inch thick	c	5	5	Handle and turn very carefully. Brush with lemon butter before and during cooking if desired. Preheat broiler to increase browning.
Ham Slices (precooked)	1 inch thick	B	8	8	Increase time 5 to 10 minutes per side for 1 ½ inch thick or home-cured ham.
Pork Chops Well Done	2 ( 1/2 inch thick) 2(1 inch thick) about 1 lb.	c B	10 13	10 13	Slash fat.
Lamb Chops Medium Well Done	2 (1 inch thick) about 10 to 12 oz.	<b>C</b> <b>C</b>	8 10	4-7 10	Slash fat.
Medium Well Done	2 (1½ inch thick) about 1 lb.	c B	10 17	4-6 12-14	
Well Done					
Wieners and similar precooked sausages, bratwurst	1 -lb. pkg. (10)	c	6	1-2	If desired, split sausages in half lengthwise; cut into 5 to 6 inch pieces.



# OPERATING THE SELF-CLEANING OVEN

Normal cleaning time: 3 hours

## Before a Clean Cycle

### Quick Reminder:

1. Prepare oven for cleaning.
2. Turn OVEN SET and OVEN TEMP knobs to CLEAN.
3. Slide the oven door latch to the right as far as it will go.
4. Set automatic oven timer.

1. Remove broiler pan, broiler rack and other cookware from the oven. (Oven shelves may be left in oven. **NOTE:** Shelves will discolor during the self-clean cycle.)

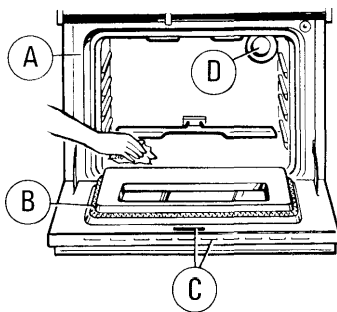

- A. Oven Front Frame
- B. oven Door Gasket
- C. Openings in Door
- D. Oven Light

2. Wipe up heavy soil on oven bottom. If you use soap, rinse thoroughly before self-cleaning to prevent staining.

3. Clean spatters or spills on oven front frame (A) and oven door outside gasket (B) with a dampened cloth. Polish with a dry cloth. Do not clean gasket (B). Do not allow water to run down through openings in top of door (C). Never use a commercial oven cleaner in or around self-cleaning oven.
- Clean top, sides and outside front of oven door with soap and water. Do not use abrasives or oven cleaners.
- Do not rub or clean the door gasket (B)—the fiberglass material of the gasket has an extremely low resistance to abrasion. An intact and well-fitting oven door gasket is essential for energy efficient oven operation and good baking results. If you notice the gasket becoming worn, frayed or damaged in any way, or if it has become displaced on the door, you should have it replaced.
4. Close oven door and make sure oven light (D) is off.

**Caution:** Chrome drip pans should never be cleaned in the self-cleaning oven.

## How to Set Oven for Cleaning

1. Turn OVEN SET and OVEN TEMP knobs to CLEAN. Controls will snap into position when the CLEAN location is reached.

2. Slide the latch handle to the right as far as it will go.

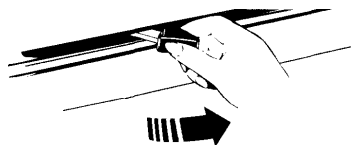

3. Set the automatic oven timer:

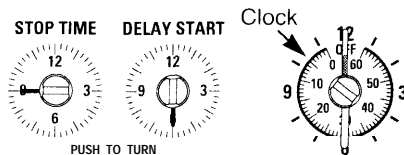

- Make sure **both** the clock and the DELAY START dial show the correct time of day. When the DELAY START knob is pushed in and turned, it will “pop” into place when the time shown on the clock is reached.

- Push in and turn STOP TIME knob. Set Stop Time for three hours later than present time of day—for example, if it is 6:00 now, set Stop Time for 9:00.
- The oven cycling light (below OVEN TEMP knob), the CLEANING light and the OVEN ON light will glow, indicating that the self-clean cycle has begun. When the oven reaches a certain temperature, the oven door will lock. The latch handle cannot be moved until oven cleaning is complete and the oven cools down. Oven door and window (on some models) get hot during self-clean cycle. **DO NOT TOUCH.**
- The oven will smoke the first time you use the self-clean cycle even though you have wiped up any excessive soil. This is normal and should stop in about 10 minutes. To help control the smoke, turn on the exhaust fan over the range when you use the self-clean cycle the first time.

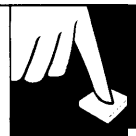

## After a Clean Cycle

After cleaning is complete, the door will stay locked until the oven cools down. This takes about 30 minutes.

1. When oven has cooled, slide the latch handle to the left as far as it will go and open the door. If the door will not open, move the latch handle back to the right, wait an additional 15 minutes and then try again. **Do not force the latch handle.**

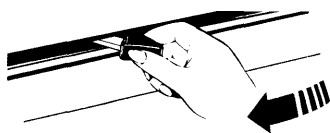

2. Turn OVEN SET knob to OFF. Turn OVEN TEMP knob to OFF (on some models).

**NOTE:** To start and stop cleaning at a time later than shown on clock, push in and turn DELAY START dial to time you wish cleaning to start. Then set STOP TIME dial for three hours later than the Start Time. Oven will automatically turn on and off at the set times.

## Questions and Answers

**Q. Why won't my oven clean immediately even though I set all the time and clean knobs correctly?**

- A. Check to be sure your DELAY START dial is set to the same time as the range clock. Also check to be sure latch handle is moved to the right.

**Q. If my oven clock is not working, can I still self-clean my oven?**

- A. **No.** Your Automatic Oven Timer uses the range clock to help start and stop the self-cleaning cycle.

**Q. Can I use commercial oven cleaners on any part of my self-cleaning oven?**

- A. **No** cleaners or coatings should be used around any part of this oven. If you do use them and do not wipe the oven absolutely clean afterward, the residue can scar the oven surface and damage metal parts the next time the oven is automatically cleaned.

**Q. Can I clean the Woven Gasket around the oven door?**

- A. **No**, this gasket is essential for a good oven seal, and care must be taken not to rub, damage or move this gasket.

**Q. After having just used the oven, I could not move the latch handle. Why?**

- A. After several continuous high-temperature bakings or broilings, the door cannot be latched. If this happens, let the oven cool by opening the oven door. After the oven has cooled, you will be able to latch the oven door for self-cleaning.

**Q. What should I do if excessive smoking occurs during cleaning?**

- A. This is caused by excessive soil, and you should switch the OVEN SET knob to OFF. Open windows to rid room of smoke. Allow the oven to cool for at least one hour before opening the door. Wipe up the excess soil and reset the clean cycle.

**Q. Is the "crackling" sound I hear during cleaning normal?**

- A. **Yes.** This is the metal heating and cooling during both the cooking and cleaning functions.

**Q. Should there be any odor during the cleaning?**

- A. **Yes.** there may be a slight odor during the first few cleanings. Failure to wipe out excessive soil might also cause an odor when cleaning.

**Q. What causes the hair-like lines on the enameled surface of my oven?**

- A. This is a normal condition resulting from heating and cooling during cleaning. They do not affect how your oven performs.

**Q. Why do I have ash left in my oven after cleaning?**

- A. **Some** types of soil will leave a deposit which is ash. It can be removed with a damp sponge or cloth.

**Q. My oven shelves do not slide easily. What is the matter?**

- A. After many cleanings, oven shelves may become so clean they do not slide easily. To make shelves slide more easily after each self-cleaning cycle, dampen fingers with a small amount of cooking oil and rub lightly over sides of shelf where they contact shelf supports.

**Q. My oven shelves have become gray after the self-clean cycle. Is this normal?**

- A. **Yes.** After the self-clean cycle, the shelves may lose some luster and change to a deep gray color.

**Q. Can I cook food on the cooktop while the oven is self-cleaning?**

- A. **Yes.** While the oven is self-cleaning, you can use the cooktop just as you normally do.

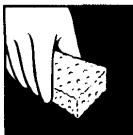

# CARE AND CLEANING

Proper care and cleaning are important so your range will give you efficient and satisfactory service. Follow these directions carefully in caring for your range to assure safe and proper maintenance.

## Cooktop Surface

To avoid damaging the porcelain enamel surface of the cooktop and to prevent it from becoming dull, clean up spills right away. Foods with a lot of acid (tomatoes, sauerkraut, fruit juices, etc.) or foods with a high sugar content could cause a dull spot if allowed to set. When the surface has cooled, wash and rinse. For other spills, such as fat smatterings, etc., wash with soap and water once the surface has cooled. Then rinse and polish with a dry cloth.

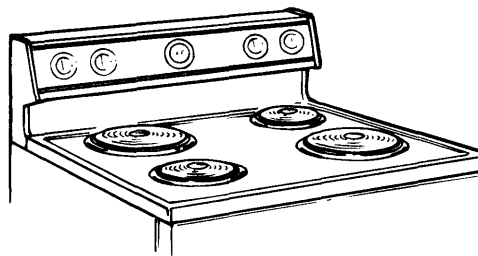

**Do not store flammable materials in an oven or near the cooktop.** Do not store or use combustible materials, gasoline or other flammable vapors and liquids in the vicinity of this or any other appliance.

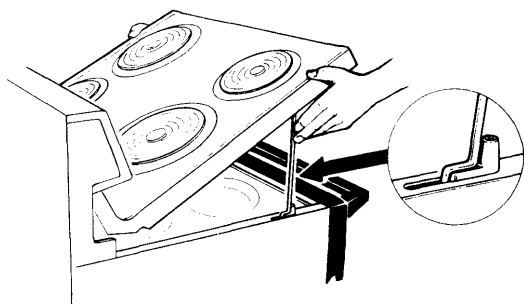

## Lift-Up Cooktop (on some models)

Some models have a cooktop that can be lifted up for easier cleaning. To make cleaning easier, the entire cooktop may be lifted up and supported in the up position. **Be sure all surface units are turned off before raising the cooktop.** There are two side supports that lock into position when the cooktop is lifted up. The Calrod™ units do not need to be removed before lifting. After cleaning under the cooktop with hot, mild soapy water and a clean cloth, lower the cooktop. Be careful not to pinch your fingers. To lower the cooktop, push the rods back and gently lower the cooktop until it rests in place.

## Calrod™ Surface Units

Spatters and spills burn away when the coils are heated. At the end of a meal, remove all pans from the Calrod™ unit and heat the soiled unit at HI. Let the soil burn off about one minute and switch the unit to OFF. Avoid getting cleaning materials on the coils. Wipe off any cleaning materials with a damp paper towel *before* heating the Calrod™ unit.

### CAUTION

- Do not immerse the surface units in liquids of any kind.
- Do not clean the surface units in a dishwasher.
- Do not bend the surface unit plug terminals.
- Do not attempt to clean, adjust or in any way repair the plug-in receptacle.

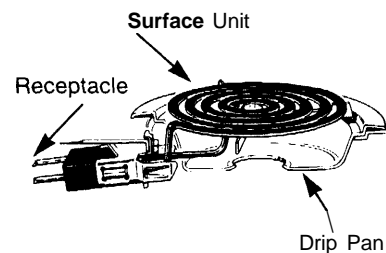

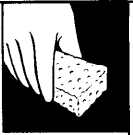

## Drip Pans

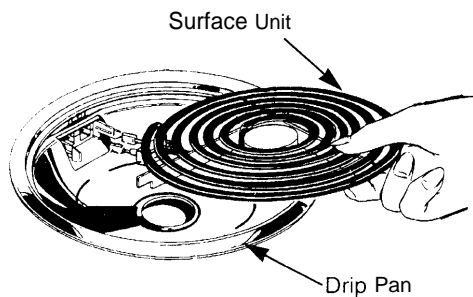

To remove the drip pans for cleaning, the surface units must be removed first. Lift the surface unit about one inch above the drip pan and pull it out. Make sure the surface units are completely cool *before* touching them. Clean the drip pans with soap and water, plastic scouring pad or in the dishwasher. **DO NOT CLEAN IN SELF-CLEANING OVEN;** pans will discolor. Wipe after each cooking so unnoticed spatter will not burn on the next time you cook.

**Do not lift the surface unit more than one inch. If you do, it may not lie flat on the drip pan when you plug it back in.**

**Repeated lifting of the surface unit more than one inch above the drip pan can permanently damage the receptacle.**

### To replace a surface unit:

- Replace the drip pan into the recess in the cooktop. Make sure opening in the pan lines up with the receptacle.
- Insert the terminals of the surface unit through the opening in the drip pan and into the receptacle.
- Guide the surface unit into place so it rests evenly.

Do not cover the drip pans with aluminum foil. Using aluminum foil so close to the receptacle could cause shock, fire or damage to the range.

## Cooktop Surface Lamp (on some models)

**When changing a cooktop lamp, do not touch the metal at the ends of the lamp.**

The cooktop light is easily replaced with a fluorescent tube of the same wattage. Before changing the lamp, pull the plug to the range or disconnect the power at the main fuse or circuit breaker panel.

### To remove:

- Lift the lamp cover by pulling the bottom edge toward you and then up.
- Place fingers on top near each end of the lamp.
- Roll the top of the lamp gently toward the front of the range and gently pull the lamp from the socket, making sure it does not hit the lamp cover.

### To replace:

- Place fingers on the top near each end of the lamp.
- Press the lamp into the slots until it snaps into place.
- Move lamp cover down and snap into place.

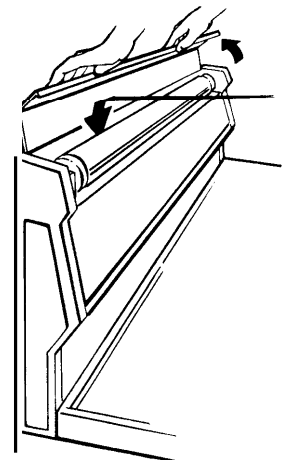

## Oven Vent

The oven is vented through an opening under the right rear surface unit. Never cover the opening with aluminum foil or any other material. This would prevent the oven vent from working properly.

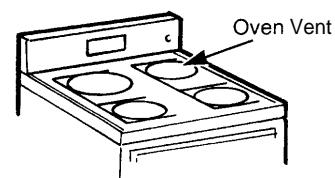

(continued next page)



# CARE AND CLEANING

(continued)

## Control Panel and Knobs

It's a good idea to wipe the control panel after each use of the oven. Clean with mild soap and water or vinegar and water, rinse with clean water and polish dry with a soft cloth.

Do not use abrasive cleansers, strong liquid cleaners, plastic scouring pads or oven cleaners on the control panel—they will damage the finish. A 50/50 solution of vinegar and hot water works well.

The control knobs may be removed for easier cleaning. To remove knob, pull it straight off the stem. If knob is difficult to remove, place a towel or dishcloth between the knob and control panel and pull gently. Wash the knobs in soap and water or a vinegar and hot water solution but do not soak.

To clean outside glass finish, use a glass cleaner. Do not allow the water or cleaner to run down inside openings in the glass while cleaning.

Metal parts can be cleaned with soap and water. Do not use steel wool, abrasives, ammonia, acids or commercial oven cleaners. Dry with a soft cloth.

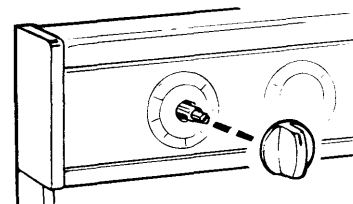

## Oven Shelves

Shelves can be cleaned by hand using soap and water or with an abrasive cleanser. After cleaning, rinse the shelves with clean water and dry. To remove heavy, burned-on soil, you may use scouring pads. After scrubbing, wash with soapy water, rinse and dry. Shelves may also be cleaned in self-cleaning oven, but will discolor and lose some luster. See the Self-Cleaning section.

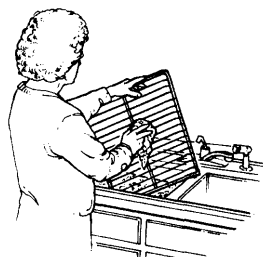

## Broiler Pan and Rack

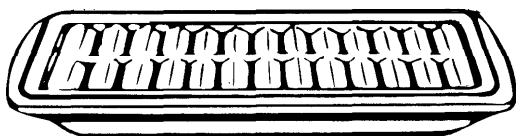

After broiling, remove the broiler pan and rack from the oven. Remove the rack from the pan. Carefully pour out the grease in the pan into a proper container.

If food has burned on, sprinkle the rack with detergent while hot and cover with wet paper towels or a dishcloth. That way, burned-on foods will soak loose while the meal is being served.

Wash; scour if necessary. Rinse and dry. The broiler pan and rack may also be cleaned in a dishwasher. Do not store a soiled broiler pan and rack anywhere in the range. Do not clean in self-cleaning oven.

## How to Remove the Storage Drawer or Kick Panel to Clean Under the Range

The area under the range can be reached easily for cleaning by removing the bottom drawer (on some models). To remove, pull the drawer out all the way, tilt up the front and remove it. To replace, insert glides at the back of the drawer beyond the stop on range glides. Lift the drawer if necessary to insert easily. Let the front of the drawer down, then push in to close.

To clean under models with a front kick panel, remove the panel by pulling it straight out at the bottom. To replace the panel, first hook the top tabs on and then the bottom tabs.

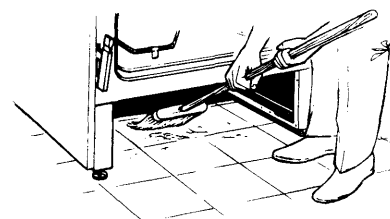





## Metal Parts

Do not use steel wool, abrasives, ammonia or commercial oven cleaners. To safely clean surfaces; wash, rinse and then dry with a soft cloth.



## Glass Surfaces

To clean the outside glass finish, use a glass cleaner. Rinse and polish with a dry cloth. Do not allow the water or cleaner to run down inside openings in the glass while cleaning.

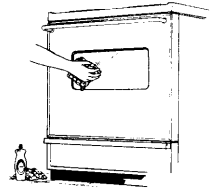

## Lift-Off Oven Door

The oven door is removable but it is heavy. You may need help removing and replacing the door.

**To remove the door,** open it a few inches to the special "stop" position that will hold the door open. Grasp firmly on each side and lift the door straight up and off the hinges.

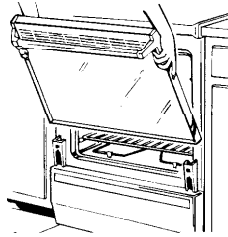

**NOTE:** Be careful not to place hands between the spring hinge and the oven frame as the spring hinge could snap back and pinch your fingers.

**To replace the door,** make sure the hinges are in the "out" position. Position the slots in the bottom of the door squarely over the hinges. Then lower the door slowly and evenly over both hinges at the same time.

### TO CLEAN THE DOOR:

( **DO** not immerse door in water.)

#### Inside of door:

- **Because** the area inside the gasket is cleaned during the self clean cycle, you do not need to clean this by hand. Any soap left on the liner causes additional stains when the oven is heated.
- The area outside the gasket can be cleaned with a scouring pad.

- Do not rub or clean the door gasket—the fiberglass material of the gasket has an extremely low resistance to abrasion. An intact and well-fitting oven door gasket is essential for energy-efficient oven operation and good baking results. If you notice the gasket becoming worn, frayed or damaged in any way or if it has become displaced on the door, you should have it replaced.

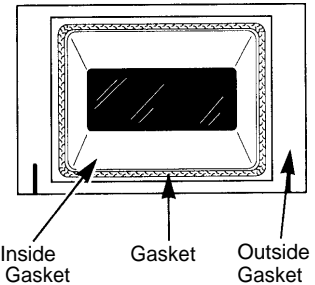

#### Outside of door:

- Use soap and water to thoroughly clean the top, sides and front of the oven door. Rinse well. You may also use a glass cleaner to clean the glass on the outside of the door.
- Spillage of marinades, fruit juices, tomato sauces and basting materials containing acids may cause discoloration and should be wiped up immediately. When surface is cool, clean and rinse.
- **Do not use oven cleaners, cleansing powders or harsh abrasives on the outside of the door.**

## Oven Lamp Replacement (on some models)

**CAUTION:** Before replacing your oven lamp bulb, disconnect the electric power for your range at the main fuse or circuit breaker panel or pull the plug.

Be sure to let the lamp cover and bulb cool completely before removing or replacing them. When in use, light bulbs can become warm enough to break if touched with a moist cloth or towel. When cleaning, avoid touching warm lamps with cleaning cloths if the lamp cover is removed.

The oven lamp (bulb) is covered with a removable glass cover which is held in place with a wire. Remove the oven door, if desired, to reach the cover easily.

#### To remove:

- Hold your hand under the cover so it doesn't fall when released.
- With fingers of the same hand, firmly push back the wire until it clears the cover. Lift off the cover.
- Do not touch hot bulb with a wet cloth.

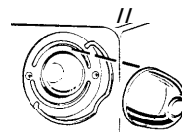

#### DO NOT REMOVE ANY SCREWS TO REMOVE COVER.

- Replace bulb with 40-watt home appliance bulb.

#### To replace cover:

- Place it into the groove of the lamp receptacle. Pull the wire forward to the center of cover until it snaps in place. When in place, the wire holds the cover firmly. Be certain the wire is in the depression in the center of the cover.
- Connect electric power to the range.



# INSTALLATION INSTRUCTIONS

## BEFORE YOU BEGIN

Read these instructions completely and carefully.

**IMPORTANT:** Save these instructions for the local electrical inspector's use.

**IMPORTANT:** OBSERVE ALL GOVERNING CODES AND ORDINANCES.

**NOTE TO INSTALLER:** Leave these instructions with the appliance after installation is completed.

**NOTE TO CONSUMER:** Keep this Use and Care Guide and Installation Instructions for future use.

**NOTE:** This appliance must be properly grounded.

## TOOLS YOU WILL NEED

Large blade screwdriver

Channel lock pliers or small ratchet wrench with 3/16" socket (for leveling range)

## ELECTRICAL REQUIREMENTS

**CAUTION, FOR PERSONAL SAFETY: DO NOT USE AN EXTENSION CORD WITH THIS APPLIANCE.**

**REMOVE HOUSE FUSE OR OPEN CIRCUIT BREAKER BEFORE BEGINNING INSTALLATION.**

This appliance must be supplied with the proper voltage and frequency, and connected to an individual, properly grounded branch circuit, protected by a circuit breaker or time delay fuse, as noted on the rating plate.

Wiring must conform to National Electric Codes.

If the electric service provided does not meet the above specifications, it is recommended that a licensed electrician install an approved outlet.

Because range terminals are not accessible after range is in position, flexible service conduit or cord must be used.

## STEP 1

### PREPARE THE OPENING

1/2" spacing is recommended from the range to adjacent vertical walls above cooktop surface.

Allow 30" minimum clearance between surface units and bottom of unprotected wood or metal top cabinet, and 15" minimum between countertop and adjacent cabinet bottom.

To eliminate the risk of burns or fire by reaching over heated surface units, cabinet storage space above the surface units should be avoided. If cabinet storage is to be provided, the risk can be reduced by installing a range hood that projects horizontally a min. of 5" beyond the bottom of the cabinets.

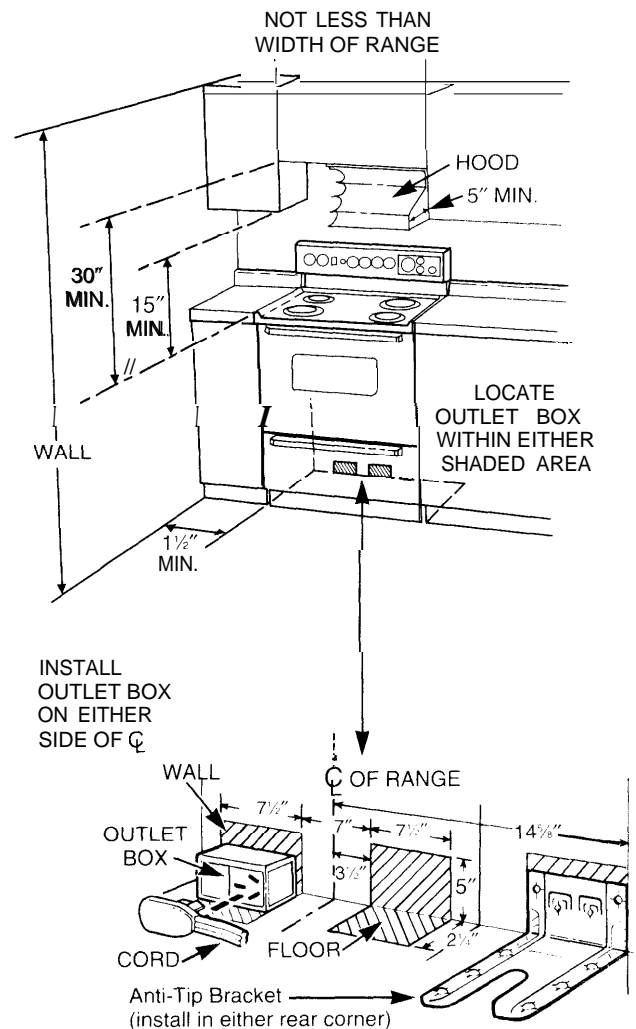



## PREPARE THE OPENING (continued)

### Flooring Under the Range

Your range, like many other household items, is heavy and can settle into soft floor coverings such as cushioned vinyl or carpeting. When moving the range on this type of flooring, use care, and follow these simple and inexpensive instructions.

The range should be installed on a 1/4 inch thick sheet of plywood (or similar material) as follows:

*When the floor covering ends at the front of the range*, the area that the range will rest on should be built up with plywood to the same level or higher than the floor covering. This will allow the range to be moved for cleaning or servicing.

## STEP 2

### PREPARE FOR ELECTRICAL CONNECTION

Use only a 3-conductor, or if required a 4-conductor range cord set as noted below. These cord sets are provided with ring type terminals.

The electrical rating of the cord must be 125/250 volts minimum, 40 amperes.

**NOTE:** Only a 4-conductor cord is to be used when the appliance is installed in a mobile home or where local codes do not permit grounding through the neutral.

## STEP 3

1. Locate connector block at the bottom rear of range and remove rear wiring cover.
2. Directly below the connector block is a hole with a knockout ring for accommodating conduit fittings. Brackets provided are used to support the flexible cord strain relief, which must be securely attached to the cord set.

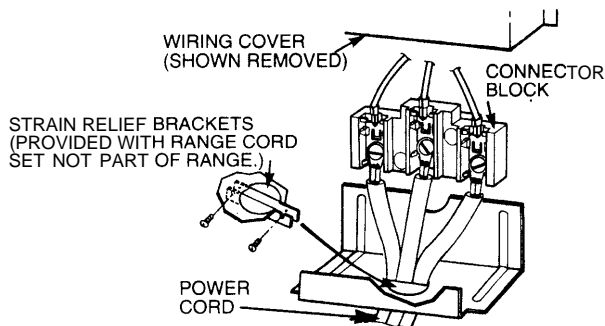

## STEP 4

### 3-WIRE SYSTEM

Power Cord Installation-Insert screws through power cord terminals so that the screws pass through connector block terminals and engage nuts. Tighten screws securely.

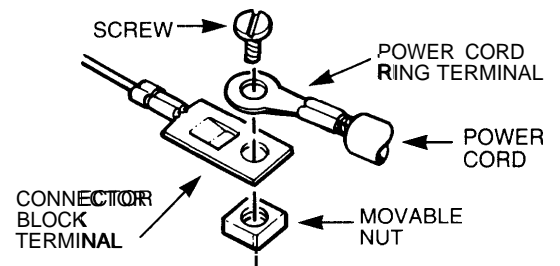

Cable Direct Installation-Clamp bare wires between the connector block terminals and movable nuts with screws tightened securely.

#### 1. Copper Wiring

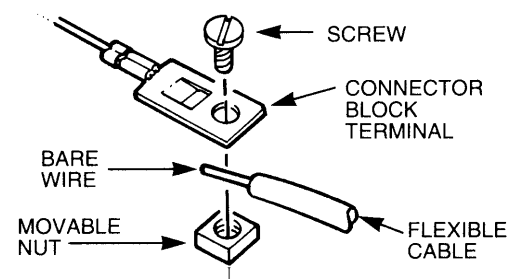

Connect the neutral or grounded wire of the supply circuit to the neutral terminal of the connector block, located in the center. The power leads must be connected to the outside (brass colored) terminals.

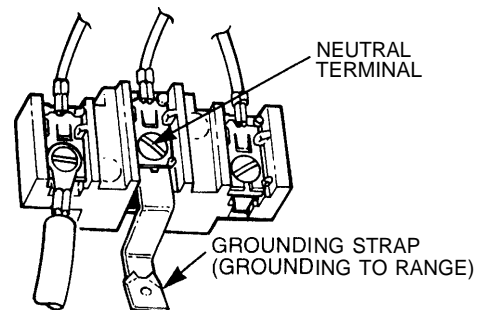

**WARNING: CONNECTOR BLOCK IS APPROVED FOR COPPER WIRE CONNECTION ONLY.**

(continued next page)



# INSTALLATION INSTRUCTIONS

(continued)

## STEP 4 (continued)

### 2. Aluminum Wiring

**A. Connect length of copper building wire to range terminal block.**

**B. Splice copper wires to aluminum wiring using special connectors designed and U.L. approved for joining copper to aluminum, and follow the connector manufacturer's recommended procedure closely.**

NOTE: Wire used, location and enclosure of splices, etc., must conform to good wiring practice and local codes.

## STEP 5

### 4-WIRE SYSTEM

### SPECIAL GROUNDING INSTRUCTIONS

#### WARNING:

Frame grounded to neutral of appliance through a link. If used in a MOBILE HOME or if LOCAL CODES do not permit grounding through the neutral:

1. Disconnect the link from neutral.
2. Use grounding terminal or lead to ground unit in accordance with local codes.
3. Connect neutral terminal or lead to branch circuit in usual manner.

(If the appliance is to be connected by means of a cord set, use 4-conductor cord for this purpose.)

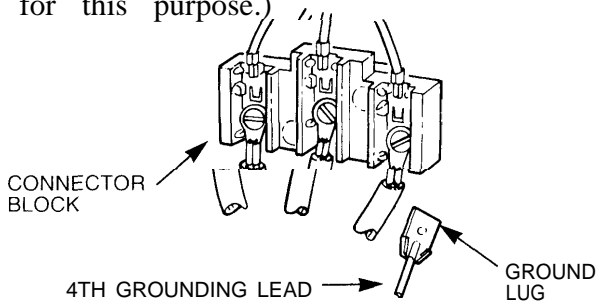

## STEP 6

### ANTI-TIP BRACKET INSTALLATION

AN ANTI-TIP bracket is supplied with instructions for installation in a variety of locations. The instructions include a template, a parts list and a list of tools necessary to complete the installation. Read the IMPORTANT SAFETY INSTRUCTIONS and the instructions that fit your situation before beginning installation.

## WARNING

1. Range must be secured by ANTI-TIP bracket supplied.
2. See instructions to install (supplied with bracket).
3. Unless properly installed, range could be tipped by stepping or sitting on door. Injury might result from spilled hot liquids or from range itself.

Typical installation of Anti-Tip bracket Attachment to Wall

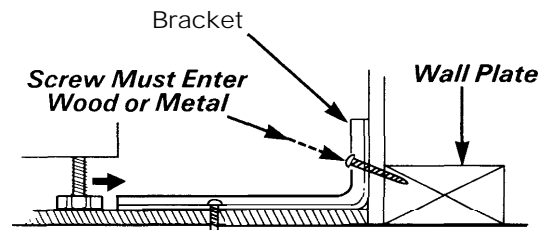

## STEP 7

### LEVELING THE RANGE

The range must be level. Leveling feet are located at each corner of the base of the range. Remove the storage drawer or kick panel (depending on your model) and using channel locks, rotate the leveling feet in and out as required to level the range. (For instructions on how to remove and replace the storage drawer or the kick panel, see the Cleaning Under the Range section in Care and Cleaning.) On some models, there are plastic covers which may be removed for easy adjustment (just squeeze and pull).

One of the rear leveling feet will engage the ANTI-TIP bracket (allow for some side to side adjustment). Allow a minimum clearance of 1/8" between the range and the leveling foot that is to be installed into the ANTI-TIP bracket.

Check the range for proper installation into the ANTI-TIP bracket (after the range has been properly installed) by grasping the edges of the REAR burner holes and carefully attempting to tilt the range forward.

## STEP 8

### FINAL CHECK

Be sure all switches are in the "off" position before leaving the range.

# QUESTIONS? USE THIS PROBLEM SOLVER



PROBLEM	POSSIBLE CAUSE
OVEN WILL NOT WORK	<ul style="list-style-type: none"> <li>• Plug on range is not completely inserted in the electrical outlet.</li> <li>• The circuit breaker in your house has been tripped, or a fuse has been blown.</li> <li>• Oven controls not properly set.</li> <li>• Door left in locked position after cleaning.</li> </ul>
OVEN LIGHT DOES NOT WORK	<ul style="list-style-type: none"> <li>• Light bulb is loose.</li> <li>• Bulb is defective. Replace.</li> <li>• Switch operating oven light is broken. Call for service.</li> </ul>
FOOD DOES NOT BROIL PROPERLY	<ul style="list-style-type: none"> <li>• OVEN SET knob not set at BROIL.</li> <li>• OVEN TEMP knob not set at BROIL.</li> <li>• Door not left ajar as recommended.</li> <li>• Improper shelf position being used. Check Broiling Guide.</li> <li>• Food is being cooked on hot pan.</li> <li>• Cookware is not suited for broiling.</li> <li>• Aluminum foil used on the broil pan rack has not been fitted properly and slit as recommended.</li> </ul>
FOOD DOES NOT ROAST OR BAKE PROPERLY	<ul style="list-style-type: none"> <li>• OVEN SET knob not set at BAKE.</li> <li>• OVEN TEMP knob not set at BAKE.</li> <li>• Shelf position is incorrect. Check Roasting or Baking Guides.</li> <li>• Oven shelf is not level.</li> <li>• Incorrect cookware or cookware of improper size is being used.</li> <li>• A foil tent was not used when needed to slow down browning during roasting.</li> </ul>
CALROD® SURFACE UNITS NOT FUNCTIONING PROPERLY	<ul style="list-style-type: none"> <li>• Surface units are not plugged in solidly.</li> <li>• Drip pans are not set securely in the cooktop.</li> <li>• Surface unit controls are not properly set.</li> </ul>

*(continued next page)*



## PROBLEM SOLVER

(continued)

PROBLEM	POSSIBLE CAUSE
OVEN WILL NOT SELF-CLEAN	<ul style="list-style-type: none"><li>• Automatic timer dials not set or <b>not</b> set properly. Clock must be set to time of day and the STOP TIME dial must be set and advanced beyond the time noted on oven clock.</li><li>• The STOP TIME dial was not advanced for long enough.</li><li>• Both OVEN SET and OVEN TEMP knobs must be set at CLEAN setting.</li><li>• During the self-cleaning function, a thick pile of spillover in the oven can leave a heavy layer of ash that can insulate the area from further heat.</li><li>• Latch handle not moved to the right.</li></ul>
OVEN DOOR WON'T LATCH	<ul style="list-style-type: none"><li>• Oven may be too hot from previous use. Open oven door to cool oven. When oven has cooled, latch handle can again be moved.</li><li>• OVEN SET knob must be at CLEAN or OFF before latch handle can be moved.</li></ul>
OVEN TEMPERATURE TOO HOT OR TOO COLD	<ul style="list-style-type: none"><li>• OVEN TEMP knob needs adjustment. See Thermostat Adjustment section.</li></ul>

If you need more help... call, toll free:  
GE Answer Center™  
800.626.2000  
consumer information service

# We'll Be There

With the purchase of your new GE appliance, receive the assurance that if you ever need information or assistance from GE, we'll be there. All you have to do is call-toll-free



## **In-Home Repair Service** **800-GE-CARES** **(800-432-2737)**

A GE Consumer Service professional will provide expert repair service, scheduled at a time that's convenient for you. Many GE Consumer Service company-operated locations offer you service today or tomorrow, or at your convenience (7:00 a.m. to 7:00 p.m. weekdays, 9:00 a.m. to 2:00 p.m. Saturdays). Our factory-trained technicians know your appliance inside and out—so most repairs can be handled in just one visit.



## **Service Contracts** **800-626-2224**

You can have the secure feeling that GE Consumer Service will still be there after your warranty expires. Purchase a GE contract while your warranty is still in effect and you'll receive a substantial discount. With a multiple-year contract, you're assured of future service at today's prices.

## **Parts and Accessories** **800-626-2002**

Individuals qualified to service their own appliances can have needed parts or accessories sent directly to their home. The GE parts system provides access to over 47,000 parts, and all GE Genuine Renewal Parts are fully warranted. VISA, MasterCard and Discover cards are accepted.

User maintenance instructions contained in this booklet cover procedures intended to be performed by any user. Other servicing generally should be referred to qualified service personnel. Caution must be exercised, since improper servicing may cause unsafe operation.



## **GE Answer Center®** **800.626.2000**

Whatever your question about any GE major appliance, GE Answer Center® information service is available to help. Your call—and your question—will be answered promptly and courteously. And you can call any time. GE Answer Center® service is open 24 hours a day, 7 days a week.

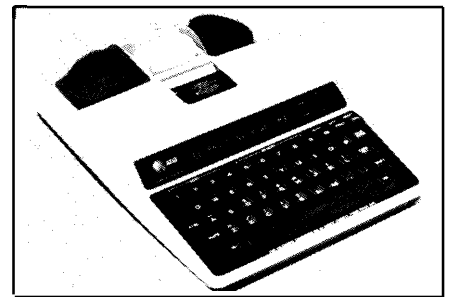

Telecommunication Device for the Deaf

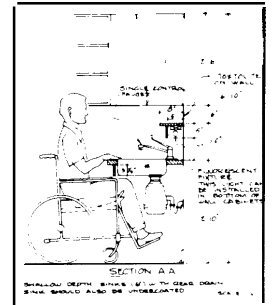
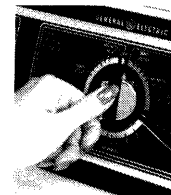

## **For Customers With Special Needs...** **800.626.2000**

Upon request, GE will provide Braille controls for a variety of GE appliances, and a brochure to assist in planning a barrier-free kitchen for persons with limited mobility. To obtain these items, free of charge, call 800.626.2000.

Consumers with impaired hearing or speech who have access to a TDD or a conventional teletypewriter may call 800-TDD-GEAC (800-833-4322) to request information or service.

# YOUR GE ELECTRIC RANGE WARRANTY

Save proof of original purchase date such as your sales slip or cancelled check to establish warranty period.

## WHAT IS COVERED

### FULL ONE-YEAR WARRANTY

For one year from date of original purchase, we will provide, free of charge, parts and service labor in your home to repair or replace **any part of the range** that fails because of a manufacturing defect.

This warranty is extended to the original purchaser and any succeeding owner for products purchased for ordinary home use in the 48 mainland states, Hawaii and Washington, D.C. In Alaska the warranty is the same except that it is LIMITED because you must pay to ship the product to the service shop or for the service technician's travel costs to your home.

All warranty service will be provided by our Factory Service Centers or by our authorized Customer Care servicers during normal working hours.

Should your appliance need service, during warranty period or beyond, call 800-GE-CARES (800-432-2737)

## WHAT IS NOT COVERED

- Service trips to your home to teach you how to use the product.

### Read your Use and Care material.

If you then have any questions about operating the product please contact your dealer or our Consumer Affairs office at the address below, or call, toll free:

GE Answer Center®  
800.626.2000  
consumer information service

- Improper installation.

If you have an installation problem, contact your dealer or installer. You are responsible for providing adequate electrical, gas, exhausting and other connecting facilities as described in the Installation Instructions provided with the product.

- Replacement of house fuses or resetting of circuit breakers.
- Failure of the product if it is used for other than its intended purpose or used commercially.
- Damage to product caused by accident, fire, floods or acts of God.

WARRANTOR IS *NOT* RESPONSIBLE FOR CONSEQUENTIAL DAMAGES.

Some states do not allow the exclusion or limitation of incidental or consequential damages, so the above limitation or exclusion may not apply to you. This warranty gives you specific legal rights, and you may also have other rights which vary from state to state. To know what your legal rights are in your state, consult your local or state consumer affairs office or your state's Attorney General.

**Warrantor: General Electric Company**

**If further help is needed concerning this warranty, write:  
Manager—Consumer Affairs, GE Appliances, Louisville, KY 40225**

*This book is printed on recycled paper.*

Part No. 164 D2588P135

pub No. 49-8335

6-92 CG

JBP22GR JBP25GR JBP26WR  
JBP22R JBP26AR JBP27C  
JBP24GR JBP26GR JBP28C