



Use and Care & Installation Guide

XL44™ Gas Range



Safety instructions2-5
 Anti-Tip Device2, 3,29, 39



Operating Instructions, Tips
 Aluminum Foil5, 16, 19
 Features6, 7
 Oven12-20
 Baking15, 16
 Broiling, Broiling Guide19,20
 Clock and Timer1, 1, 12
 Control Settings12, 15, 17, 19
 Light; Bulb Replacement14,24
 Preheating15, 18
 Roasting, Roasting Guide17, 18
 Shelves13-15
 Surface Cooking8-10
 Control Settings8
 Electric ignition8
 Standing Pilot Models8



Care and Cleaning2 I-27
 Air Adjustment Shutter27
 Continuous Clean26
 Broiler Drawer27
 Broiler Pan and Rack24
 Burner Assembly2, 1,22,23
 Door Removal25
 Lift-up Cooktop24
 Oven Bottom2, 3
 Oven Vents2, 5
 Storage Drawer27



Problem Solver45, 46
 Thermostat Adjustment-
Do It Yourself46
 More questions?...call
 GE Answer Center™80-626.2000



Preparation28-44
 Flame Size10,35-37,45,46
 Flooring Under the Range30
 Installation Instructions28-44
 Leveling39



Consumer Services47
 Appliance Registration2
 Important Phone Numbers47
 Model and Serial Number Location2
 WarrantyBack Cover

- Standard-Clean Models:**
JGBS02EN JGBS14GES
JGBS02PN JGBS15GER
JGBS04ER JGBS16GEP
JGBS04PR JGBS17GER
JGBS04GER JGBS18GES
JGBS04GPR JGBS19GEP
JGBS06ER JGSS05GER
JGBS06ES JGSS05GES
JGBS12GER
Contiguous-Clean Models:
JGBC15GER JGBC16GEP
JGBC17GER



HELP US HELP YOU...

Read this book carefully.

It is intended to help you operate and maintain your new range properly.

Keep it handy for answers to your questions.

If you don't understand something or need more help, write (include your phone number):

Consumer Affairs
GE Appliances
Appliance Park
Louisville, KY 40225

Write down the model and serial numbers.

Depending on your range, you'll find the model and serial numbers on a label on the front of the range, behind the kick panel, storage drawer or broiler drawer.

These numbers are also on the Consumer Product Ownership Registration Card that came with your range. Before sending in this card, please write these numbers here:

Model Number

Serial Number

Use these numbers in any correspondence or service calls concerning your range.

If you received a damaged range...

Immediately contact the dealer (or builder) that sold you the range.

Save time and money. Before you request service . . .

Check the Problem Solver in the back of this book. It lists causes of minor operating problems that you can correct yourself.

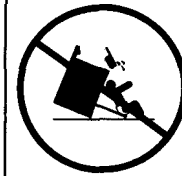

A WARNING

- ALL RANGES CAN TIP.
- INJURY TO PERSONS COULD RESULT.
- INSTALL THE ANTI-TIP DEVICE PACKED WITH THE RANGE.
- SEE THE INSTALLATION INSTRUCTIONS.

IF YOU NEED SERVICE...

To obtain service, see the Consumer Services page in the back of this book.

To obtain replacement parts, contact GE/Hotpoint Service Centers.

We're proud of our service and want you to be pleased. If for some reason you are not happy with the service you receive, here are three steps to follow for further help.

FIRST, contact the people who serviced your appliance. Explain why you are not pleased. In most cases, this will solve the problem. NEXT, if you are still not pleased, write all the details—including your phone number—to:

Manager, Consumer Relations
GE Appliances
Appliance Park
Louisville, KY 40225

FINALLY, if your problem is still not resolved, write:

Major Appliance Consumer
Action Panel
20 North Wacker Drive
Chicago, IL 60606

WARNING: If the **information** in this **manual** is not followed exactly, a fire or explosion may result **causing** property damage, **personal** injury or death.

—Do not store or use gasoline or other flammable vapors and liquids in the vicinity of this or any other appliance.

—WHAT TO DO IF YOU SMELL GAS

- Do not try to light any appliance.
- Do not touch any electrical switch; do not use any phone in your bolting.

• Immediately call your gas supplier from a neighbor's phone. Follow the gas supplier's instructions.

• If you cannot reach your gas supplier, call the fire department,

—Installation and service must be performed by a qualified installer, service agency or the gas supplier.

IMPORTANT SAFETY INSTRUCTIONS

Read all instructions before using this appliance.



IMPORTANT SAFETY NOTICE

- The California Safe Drinking Water and Toxic Enforcement Act requires the Governor of California to publish a list of substances known to the state to cause cancer, birth defects or other reproductive harm, and requires businesses to warn customers of potential exposure to such substances.
- Gas appliances can cause minor exposure to four of these substances, namely benzene, carbon monoxide, formaldehyde and soot, caused primarily by the incomplete combustion of natural gas or LP fuels. Properly adjusted burners, indicated by a bluish rather than a yellow flame, will minimize incomplete combustion. Exposure to these substances can be minimized by venting with an open window or using a ventilation fan or hood.
- Fluorescent **light bulbs** and safety valves on standing **pilot** ranges contain **mercury**. If your model has these features, they must be recycled according to local, state and federal codes.

When You Get Your Range

- Have the installer show you the location of the range gas cut-off valve and how to shut it off if necessary.
- Have your range installed and properly grounded by a **qualified installer**, in accordance with the Installation Instructions. Any adjustment and service should be performed only by qualified gas range installers or service technicians.
- **Plug** your range into a 120-volt grounded outlet only. Do not remove the round grounding prong from the plug. If in doubt about the grounding of the home electrical system, it is your personal responsibility and obligation to have an ungrounded outlet replaced with a properly grounded, three-prong outlet in accordance with the National Electrical Code. In Canada, the appliance must be electrically grounded in accordance with the Canadian Electrical Code. Do not use an extension cord with this appliance.
- Do **not** attempt to repair or replace any part of your range unless it is specifically recommended in this guide. All other servicing should be referred to a qualified technician.
- Be sure all packing materials are removed from the range before operating it to prevent fire or smoke damage should the packing material ignite.

- **Locate the range** out of kitchen **traffic** path and **out of drafty locations** to prevent **pilot outage** (on models with standing pilots) and **poor air circulation**.
- Be sure your range is correctly adjusted by a **qualified service technician or installer for the type of gas (natural or LP)** that is to be used. Your range can be converted for use with either type of gas. See the Installation Instructions, **WARNING: These adjustments** must be made by a qualified service technician in accordance with the manufacturer's instructions and all codes and requirements of the authority having jurisdiction. Failure to follow these instructions could result in serious injury or property damage. The qualified agency performing this work assumes responsibility for the conversion.
- After prolonged use of a range, **high floor temperatures may result and many floor coverings will not withstand this kind of use**. Never install the range over vinyl tile or linoleum that cannot withstand such type of use. Never install it directly over interior kitchen carpeting.

Using Your Range

- Do **not** leave **children alone or unattended** where a range is hot or in operation. They could be seriously burned.
- CAUTION: **ITEMS OF INTEREST TO CHILDREN SHOULD NOT BE STORED IN CABINETS ABOVE A RANGE OR ON THE BACKSPASH OF A RANGE—CHILDREN CLIMBING ON THE RANGE TO REACH ITEMS COULD BE SERIOUSLY INJURED.**

WARNING—All ranges can tip and injury could result, To prevent accidental



tipping of the range, **attach** an approved Anti-Tip device to the wall. (See Installation Instructions.) To check if the device is installed and engaged properly, carefully tip the range forward. The Anti-Tip device should engage and prevent the range from tipping over,

If you pull the range out from the wall for any reason, make sure the Anti-Tip device is engaged when you push the range back against the wall,

(continued next page)



IMPORTANT SAFETY INSTRUCTIONS

(continued)

- Do not allow anyone to **climb**, stand or hang on **the door, storage or broiler drawer (on some models) or range top**. They could damage the range and even tip it over, causing severe personal injury.

• Let the burner grates and other surfaces cool before touching them or leaving them where children **can** reach them.

- **Never** wear loose fitting or hanging garments while using the **appliance**. Be careful when reaching for items stored in cabinets over the cooktop. Flammable material could be ignited if brought in contact with flame or hot oven surfaces and may cause severe burns.

- For your safety, never use your appliance for warming or heating the room.

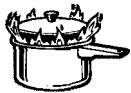

- Do not use water on grease fires. Never pick up a flaming pan. Turn off burner, then smother flaming pan by covering pan completely with well-fitting lid, cookie sheet or flat tray. Flaming grease outside a pan can be put out by covering with baking soda or, if available, a multi-purpose dry chemical or foam-type fire extinguisher.
- **Do not store** flammable materials in an oven, a range storage or broiler drawer or near a cooktop.
- Do not store **or** use combustible materials, gasoline or other flammable vapors and liquids in the vicinity of this or any other appliance.
- Do not let cooking grease or other flammable materials accumulate in or near the range.
- When cooking pork, follow the directions exactly and always cook the meat to an internal temperature of at least 170°F. This assures that, in the remote possibility that trichina may be present in the meat, it will be killed and the meat will be safe to eat.

Surface Cooking

- Always use the **LITE** position (on models with electric ignition) or the HI position (on models with standing pilots) when igniting top burners and make sure the burners have ignited.
- **Never leave surface burners unattended at high flame settings**. Boilover causes smoking and greasy spillovers that may catch on fire.

- Adjust top burner flame size so it does not extend beyond the edge of the cookware. Excessive flame is hazardous,



- Use only dry pot **holders**—moist or damp potholders on hot surfaces may result in burns from steam. Do not let pot holders come near open flames when lifting cookware. Do not use a towel or other bulky cloth in place of a pot holder.
- To minimize the possibility of burns, ignition of flammable materials, and spillage, turn cookware handles toward the side or back of the range without extending over adjacent burners.
- Always turn surface **burner** to OFF before removing cookware.
- Carefully watch foods being fried at a high flame setting.
- Never block the vents (air openings) of the range. They provide the air inlet and outlet that are necessary for the range to operate properly with correct combustion. Air openings are located at the rear of the cooktop, at the top and bottom of the oven door, and at the bottom of the range, under the kick panel, storage drawer or broiler drawer (depending on the model),
- Do not use a **wok on models with sealed burners if the wok has a round metal ring that is placed over the burner grate to support the wok**. This ring acts as a heat trap, which may damage the burner grate and burner head. Also, it may cause the burner to work improperly. This may cause a carbon monoxide level above that allowed by current standards, resulting in a health hazard.
- Foods for frying **should** be as dry as possible. Frost on frozen foods or moisture on fresh foods can cause hot fat to bubble up and over sides of pan.
- Use least possible **amount** of fat for effective **shallow** or deep-fat frying. Filling the pan too full of fat can cause **spillovers** when food is added.
- If a combination of oils or fats will be used in frying, stir together before heating or as fats melt slowly.
- **Always** heat fat slowly, and watch as it **heats**.
- Use a deep fat thermometer whenever possible to prevent overheating fat beyond the smoking point.



- **Use proper pan size**—Avoid pans that are unstable or easily tipped. Select cookware having flat bottoms large enough to properly contain food and avoid boilovers and spillovers and large enough to cover burner grate. This will both save cleaning time and prevent hazardous accumulations of food, since heavy spattering or spillovers left on range can ignite. Use pans with handles that can be easily grasped and remain cool.

- **When using glass cookware**, make sure it is designed for top-of-range cooking.

- Keep all plastics away from top burners.

- Do not leave plastic items on the cooktop—they may melt if left too close to the vent.



- Do not leave any items on the **cooktop**. The hot air from the vent may ignite flammable items and will increase pressure in closed containers, which may cause them to burst.

- To **avoid** the possibility of a burn, always be certain that the controls for all burners are at the OFF position and all grates are cool before attempting to remove them.

- When flaming foods are under the hood, turn the fan off. The fan, if operating, may spread the flames.

- If range is located near a window, do not hang long curtains that could blow over the top burners and create a fire hazard.

- **When a pilot goes out** (on a model with standing pilots), you will detect a faint odor of gas as your signal to relight the pilot. When relighting the pilot, make sure burner controls are in the OFF position, and follow instructions in the Surface Cooking section to relight.

- If you smell gas, and you have already made sure pilots are lit (on some models), turn off the gas to the range and call a qualified service technician. Never use an open flame to locate a leak.

Baking, Broiling and Roasting

- Do not use oven for a storage area. Items stored in the oven can ignite.
- Stand away from the range when opening the door of a hot oven. The hot air and steam that escapes can cause burns to hands, face and eyes.

- Keep the oven free from grease buildup.

- Place the oven shelves in desired position while oven is cool.

- Pulling out the shelf to the shelf-stop is a convenience in lifting heavy foods. It is **also** a precaution against burns from touching hot surfaces of the door or oven walls. The lowest position **“R”** is not designed to slide.

- Do not heat unopened food containers. Pressure could build up and the container **could** burst, causing an injury.

- Do not use aluminum foil anywhere in the oven except as described in this book. Misuse could result in a fire hazard or damage to the range.

- When using cooking or roasting bags in oven, follow the manufacturer’s directions.

- Use only glass cookware that is recommended for use in gas ovens,

- Always remove broiler pan from oven as soon as you finish broiling. Grease left in the pan can catch fire if oven is used without removing the grease from the broiler pan.

- When broiling, **if** meat is too close to the flame, the fat may ignite. Trim excess fat to prevent excessive flare-ups.

- Make sure broiler pan is in place correctly to reduce the possibility of grease fires.

- If you should have a grease fire in the broiler pan, turn off oven, and keep oven door closed to contain fire until it burns out.

Cleaning Your Range



- Clean only parts listed in this Use and Care Guide.

- Keep range clean and free of **accumulations** of grease or spillovers, which may ignite.

- Be careful when you clean the **cooktop** because the area over the **pilot** (on some models) will be hot.

- For continuous clean models, do **not** use oven cleaners on the oven inside or any of the continuous cleaning surfaces. Continuous cleaning surfaces can be identified by their rough surface finish.

SAVE THESE INSTRUCTIONS



FEATURES OF YOUR RANGE

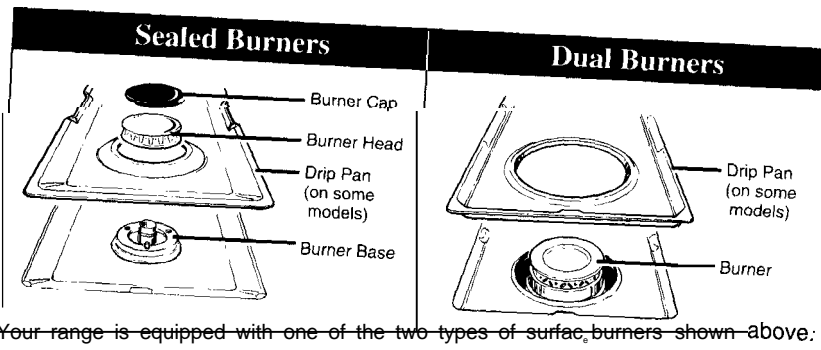
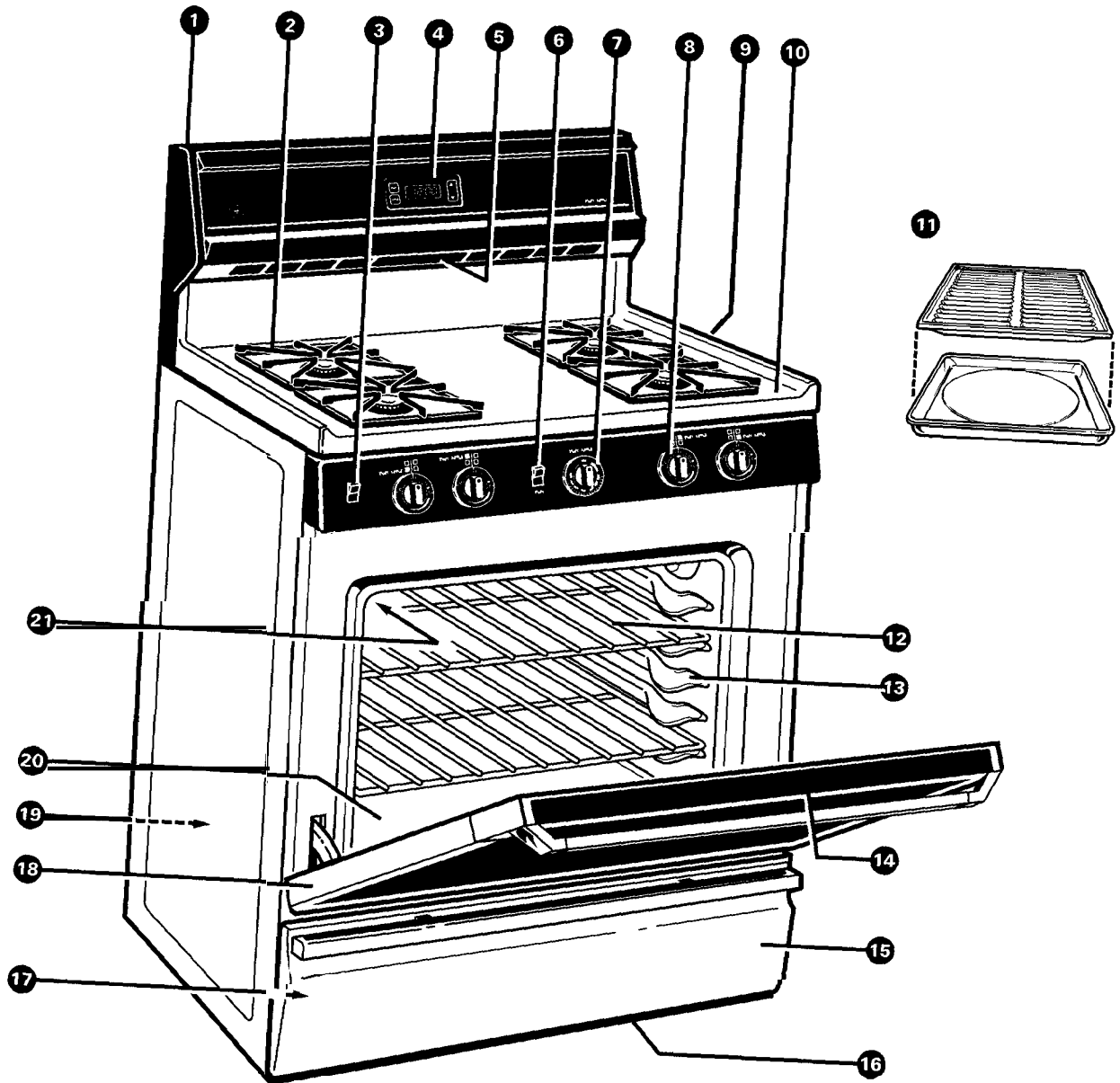

Your range is equipped with one of the two types of surface burners shown above.



Feature Index (Not all models have all features. Appearance of features varies.)	See page
1 Backguard (on some models)	—
2 Surface Burners, Grates and Drip Pans (on some models)	21,22,23
3 Oven Lamp On/Off Switch (on some models)	14
4 Clock and Timer (on some models)	11, 12
5 Oven Vent (located on cooktop on some models)	4,5, 13,25
6 Bake/Broil Switch (on some models)	12
7 Oven Control	12
8 Surface Burner Controls	8
9 Gas Shut Off Valve (on some models)	46
10 Cooktop/Liftup Cooktop (on some models)	23,24
11 Broiler Pan and Rack	19,24
12 Oven Shelves with stop-locks (Number of shelves varies)	13-15,24
13 Oven Shelf Supports (Shelf positions for cooking are suggested in the Baking, Roasting and Broiling sections.)	13, 14
14 Air Vent in Oven Door (Located at top of Oven Door)	4,25
15 Broiler Drawer or Storage Drawer (on some models)	27
16 Air Intake	4,27
17 Model and Serial Numbers (Located on front frame of range, behind either Broiler Drawer or Storage Drawer)	2,30
18 Removable Oven Door	25
19 Anti-Tip Device (Lower right rear corner on range back. See Installation Instructions.)	3,29,39
20 Oven Bottom	23
21 Oven Interior Light (on some models) On some models, comes on automatically when door is opened.	14,24

NOTE: All models have standard oven interiors, except for **JGBC15GER**, **JGBC16GEP**, and **JGBC17GER** which have continuous-cleaning oven interiors. See the Care and Cleaning section for instructions.



SURFACE COOKING

Electric Ignition Models

Your surface burners are lighted by electric ignition, eliminating the need for standing pilot lights with constantly burning flames.

In case of a power failure, you can light the surface burners on your range with a match. Hold a lighted match to the burner, then turn the knob to the **LITE** position. Use **extreme** caution when lighting burners this way.

Surface burners in use when an electrical power failure occurs will continue to operate normally.

The electrode of the spark igniter is exposed. When one burner is turned to **LITE**, all the burners spark. Do not attempt to disassemble or clean around any burner while another burner is on. An **electric** shock may result, which could cause you to knock over hot cookware.

Standing Pilot Models

The surface burners on these ranges have standing pilots that must be lit initially. To light them:

1. Be sure surface burner control knobs are in the **OFF** position.
2. Remove the grates and lift the cooktop up (see the Lift-Up Cooktop section).
3. Locate the two pilot ports and light each of them with a match.

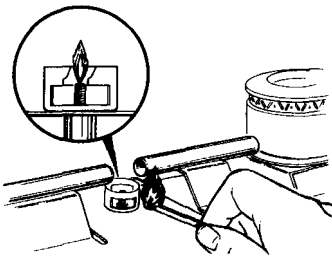

- NOTE:** If the pilot is too high or low, you can adjust it. See the Adjust the Surface Burner Pilots If Necessary section of the Installation Instructions.
4. Lower the **cooktop**. Your surface burners are now ready for use.
 5. Observe lighted burners. Compare the flames to pictures in the Problem Solver. If any flame is unsatisfactory, **call** for service.

Surface Burner Controls

Knobs that turn the surface burners on and off are marked as to which burners they control. The two knobs on the left control the left front and left rear burners. The two knobs on the right control the right front and right rear burners.

On ranges with sealed burners:

- The smaller burner (right rear position) will give the best simmer results.
- The right front burner is higher powered than the others and will bring liquids to a boil quicker (natural gas installations only).



Before Lighting a Burner

- If drip pans are supplied with your range, they should be used at all times.
- Make sure all grates on the range are in place before using any burner.

To Light a Surface Burner

Electric Ignition Models:

Push the control knob in and turn it to **LITE**. You will hear a little “clicking” noise—the sound of the electric spark igniting the burner.

After the burner ignites, turn the knob to adjust the flame size.

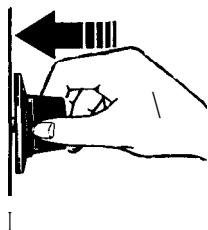

Standing Pilot Model:

Push control knob in and turn it to HI position. The burner should light within a few seconds.

After the burner ignites, turn the knob to adjust the flame size.

Flame will be almost horizontal and will lift slightly away from the burner when the burner **is** first turned on. A blowing or hissing sound may be heard for 30 to 60 seconds. This normal sound is due to improved injection of gas and air into the burner. Put a pan on the burner before lighting it, or adjust the flame to match pan size as soon as it lights, and the blowing or hissing sound will be much less noticeable.

After Lighting a Burner

- Check to be sure the burner you turned on is the one you want to use.
- Do not operate a burner for an extended period of time without cookware on the grate. The finish on the grate may chip without cookware to absorb the heat.
- Be sure the burners and grates are cool before you place your hand, a pot holder, cleaning cloths or other materials on them.

(continued next page)



SURFACE COOKING

(continued)

How to Select Flame Size

Watch the flame, not the knob, as you reduce heat.

The flame size on a gas burner should match the cookware you are using.

**FOR SAFE HANDLING OF COOKWARE
NEVER LET THE FLAME EXTEND
UP THE SIDES OF THE COOKWARE.**

Any flame larger than the bottom of the cookware is wasted and only serves to heat the handle.



Top-of-Range Cookware

Aluminum: Medium-weight cookware is recommended because it heats quickly and evenly. Most foods brown evenly in an aluminum skillet. Use saucepans with tight-fitting lids when cooking with minimum amounts of water.

Cast-Iron: If heated slowly, most skillets will give satisfactory results.

Enamelware: Under some conditions, the enamel of some cookware may melt. Follow cookware manufacturer's recommendations for cooking methods.

Glass: There are two types of glass cookware—those for oven use only and those for top-of-range cooking (saucepans, coffee and teapots). Glass conducts heat very slowly.

Heatproof Glass Ceramic: Can be used for either surface or oven cooking. It conducts heat very slowly and cools very slowly. Check cookware manufacturer's directions to be sure it can be used on gas ranges.

Stainless Steel: This metal alone has poor heating properties and is usually combined with copper, aluminum or other metals for improved heat distribution. Combination metal skillets usually work satisfactorily if they are used with medium heat as the manufacturer recommends.

Wok Cooking

(on models with sealed burners)

- We recommend that you use only a flat-bottomed wok. They are available at your local retail store.
- Do not use woks that have support rings. Use of these types of woks, with or without the ring in place, can be dangerous. Placing the ring over the burner grate may cause the burner to work improperly resulting in carbon monoxide levels above allowable current standards. This could be dangerous to your health. Do not try to use such woks without the ring. You could be seriously burned if the wok tipped over.

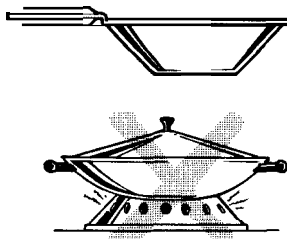

Use of Stove Top Grills

(on models with sealed burners)

Do not use stove top grills on your sealed gas burners. If you use the stove top grill on the sealed gas burner it will cause incomplete combustion and can result in exposure to carbon monoxide levels above allowable current standards. This can be hazardous to your health.

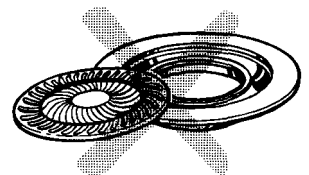

CLOCK AND TIMER



Follow the directions below if your range has the clock and timer shown at the right.

The electronic range clock and timer allow you to set the timer up to 9 hours and 45 minutes. You have the choice of having the timer show the time counting down or the time of day. In either case, the timer will signal at the end of the timer period to alert you that the time is up.



To Set the Clock

NOTE: When you first plug in the range or after a power failure, the entire **Clock/Timer** display will light up. After several seconds “12:00” will then flash on the display.

1. Press the **CLOCK** pad. “12:00” stops flashing and “SET TIME” flashes on the display.
2. Press and hold the **UP** or **DOWN** pad and the time of day will change 10 minutes at a time. To change the time by single minutes, give the pads short taps.

For example, to set the clock for 3:15, press and hold the **UP** pad until “3:10” appears, and then tap the **UP** pad until “3:15” is displayed.

3. Press the **CLOCK** pad and the clock will be set. If you do not press the **CLOCK** pad, the clock will automatically be set within one minute.

To Set the Timer

1. Press the **TIMER** pad. “:00” appears on the display and “SET TIMER” flashes.
2. Use the **UP** and **DOWN** pads to set the timer. Short taps on the **UP** or **DOWN** pad change the timer’s setting one minute at a time. Pressing and continuing to hold the **UP** pad increases the setting five minutes at a time until one hour (“1:00”) is displayed. After one hour is displayed, pressing and holding the **UP** pad increases the setting 15 minutes at a time. (Short taps on the **UP** and **DOWN** pads will always change the setting by 1-minute increments.) The timer can be set for a maximum of 9 hours and 45 minutes.
3. To start the timer, press the **TIMER** pad. If the **TIMER** pad is not pressed, the timer will automatically start after a few seconds.

As the timer counts down, a single beep will indicate when one minute is left. After this beep, the display will count down in seconds. When the timer reaches “:00,” you will hear three sets of three short beeps, and then a single beep every 10 seconds for 10 minutes or until you press any of the **Clock/Timer** pads.

To Change or Cancel the Timer Setting

When the timer is counting down, use the **UP** and **DOWN** pad to change the remaining time, or press the **TIMER** pad to cancel the timer function. The timer function cannot be **cancelled** until “SET TIMER” stops flashing and “TIMER” appears on the display.

To Display the Time of Day While the Timer Is Operating

Pressing the **CLOCK** pad while the timer is operating will not interfere with the timer’s operation; the display will change to show the time of day, but the timer will continue to count down and will still signal when time is up. Simply press the **TIMER** pad again to change the display back to show the timer function.

(continued next page)



CLOCK AND TIMER

(continued)

Clock

Follow these directions if your range has the clock and timer shown at the right. To set the clock, push in the knob and turn it to the right. Let the knob pop out when the clock hands reach the correct time. Continue turning the knob to OFF.

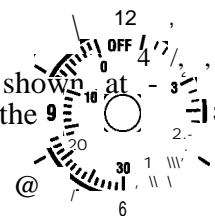

Timer

The Timer has been combined with the range clock. Use it to time all your precise cooking operations. You'll recognize the Timer as the pointer that is different in color than the clock hands.

Minutes are marked up to 30, and hours are marked up to 4 on the center of the clock.

To set the Timer, turn the knob to the left—without pushing in—until the pointer reaches the number of minutes or hours you want to time.

At the end of the set time, a buzzer sounds to tell you time is up. Turn the knob—without pushing in—until the pointer reaches OFF and the buzzer stops.

USING YOUR OVEN

Before Using Your Oven

Be sure you understand how to set the controls properly. Practice removing and replacing the shelves while the oven is cool. Read the information and tips on the following pages. Keep this book handy where you can refer to it, especially during the first weeks of using your new range.

Oven Control

Your oven is controlled either by a single OVEN CONTROL knob or by a **BAKE/BROIL** switch and an OVEN CONTROL knob.

It will normally take 30-90 seconds before the flame comes on. After the oven reaches the selected temperature, the oven burner cycles—off completely, then on with a full flame—to maintain the selected temperature.

If your range is equipped with a separate **BAKE/BROIL** switch:

Turn switch to **BAKE** for all normal oven operations—for example, for cooking roasts or casseroles. Only the bottom oven burner operates when the **BAKE** setting is selected.

Use the **BROIL** setting for broiling. Only the top oven burner operates when the **BROIL** setting is selected.

Electric Ignition Models

The oven burner and broil burner are lighted by electric ignition.

To light either burner, turn the OVEN CONTROL knob to the desired temperature. The burner should ignite within 30-90 seconds.

After the oven reaches the selected temperature, the oven burner cycles—off completely, then on with a full flame—to keep the oven temperature controlled,

Power Outage

CAUTION: DO NOT MAKE ANY ATTEMPT TO OPERATE THE ELECTRIC IGNITION OVEN DURING AN ELECTRICAL POWER FAILURE. The oven or broiler cannot be lit during a power failure. Gas will not flow unless the glow bar is hot.

If the oven is in use when a power failure occurs, the oven burner shuts off and cannot be **re-lit** until power is restored.



Standing Pilot Models

These ranges have standing pilots that must be lit initially.

To light the oven pilot:

1. Be sure the OVEN CONTROL knob is in the OFF position.
2. Open the broiler door and remove the broiler pan and rack. This will make it easier for you to reach inside the broiler compartment.

3. Find the oven pilot port at the back of the broiler compartment. The long tube, running from front to back, is the oven burner. The pilot port is at the back about one inch below the burner.
4. Using a long match or match holder, reach in and light the oven pilot.

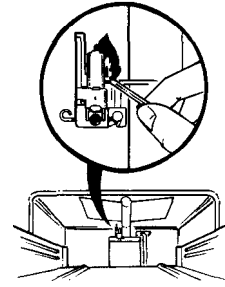

Oven Vents

The oven is vented through duct openings at the rear of the cooktop. See Features section. Do not block these openings when cooking in the oven—it is important that the flow of hot air from the oven and fresh air to the oven burners be uninterrupted.

- The vent openings and nearby surfaces may become hot. Do not touch them.
- Do not leave plastic items on the cooktop—they may melt if left too close to the vent.

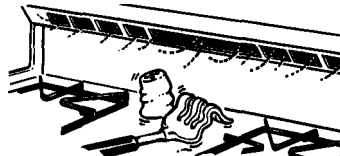

Vent appearance and location vary

- Handles of pots and pans on the cooktop may become hot if left too close to the vent.
- Metal items will become very hot if they are left on the cooktop and could cause burns.
- Do not leave any items on the cooktop. The hot air from the vent may ignite flammable items and will increase pressure in closed containers, which may cause them to burst.

Oven Shelves

The shelves are designed with stop-locks so when placed correctly on the shelf supports, they will stop before coming completely out of the oven and will not tilt when you are removing food from them or placing food on them.

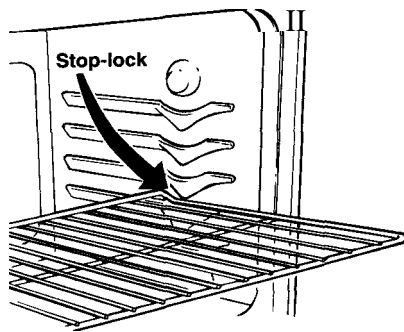

To remove a shelf from the oven, pull it toward you, tilt the front end upward and pull the shelf out.

To replace, place the shelf on the shelf support with the stop-locks

(curved extension of the shelf) facing up and toward the rear of the oven. Tilt up the front and push the shelf toward the back of the oven until it goes past "stop" on the oven wall. Then lower the front of the shelf and push it all the way back.

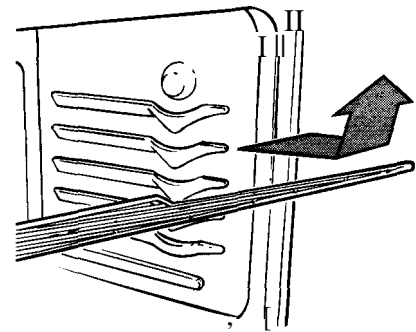

(continued next page)



USING YOUR OVEN

(continued)

Shelf Positions

The oven has 5 shelf supports for normal baking and roasting identified in this illustration as A (bottom), B, C, D and E (top). It also has a special low shelf position (R) for roasting extra large items, such as a large turkey—the shelf is not designed to slide out at this position. Shelf positions for cooking are suggested on the Baking and Roasting pages.

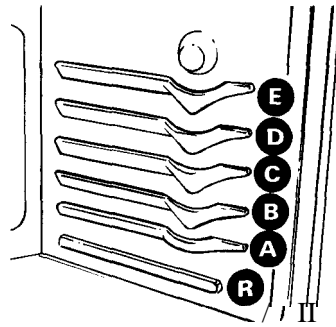

Oven Moisture

As your oven heats up, the temperature change of the air in the oven may cause water droplets to form on the door glass. These droplets are harmless and will evaporate as the oven continues to heat up.

Oven Light (on some models)

The oven light comes on automatically when the door is opened. Some models have a switch on the lower control panel that allows you to turn the light on or off when the door is closed.

Do It Yourself—Adjust the Oven Thermostat

If you don't think the oven is heating at the right temperature when you are baking or roasting, you can reset the thermostat yourself.

When cooking food for the first time in your new oven, use time given on recipes as a guide. Oven thermostats, over a period of years, may "drift" from the factory setting and the differences in timing between an old and a new oven of 5 to 10 minutes are not unusual. Your oven has been set correctly at the factory and is more likely to be accurate than the oven which it replaced.

We do not recommend the use of inexpensive thermometers, such as those found in the grocery store, to check the temperature setting of your new oven. These thermometers can vary by 20–40 degrees.

To decide how much to change the temperature, set the oven temperature 25°F. higher or lower than the temperature in your recipe, then bake. The results of this "test" should give you an idea of how much the temperature should be changed.

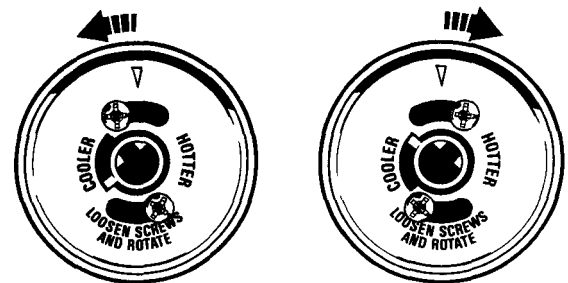

Pull the OVEN CONTROL knob off the range and look at the back side.

To make the adjustment, loosen (approximately 1 turn), but do not completely remove, the 2 screws on the back of the knob. With the back of the knob facing you, hold the outer edge of the knob with one hand and turn the front of the knob with the other hand.

To raise the oven temperature, move the top screw toward the right. You'll hear a click for each notch you move the knob. To lower the temperature, move the top screw toward the left. Each click will change the oven temperature approximately 10°F. (Range is plus or minus 60°F. from the arrow.)

We suggest that you make the adjustment 1 click from the original setting and check oven performance before making any additional adjustments.

After the adjustment is made, retighten the screws so they are snug, but be careful not to overtighten. Reinstall the knob on the range and check performance.

BAKING



How To Set Your Range For Baking

To avoid possible burns, place the shelves in the correct position before you turn the oven on.

1. Close the oven door. If your model has a separate BAKE/BROIL switch, turn it to BAKE. Turn the OVEN CONTROL knob to the desired temperature.

2. Check food for doneness at minimum time on recipe. Cook longer if necessary. When cooking is finished, turn the OVEN CONTROL knob to OFF and remove food.

For best baking results, follow these suggestions:

Oven Shelves

Arrange the oven shelf or shelves in the desired locations while the oven is cool. The correct shelf position depends on the kind of food and the browning desired.

As a general rule, place most foods in the middle of the oven, on either shelf position B or C. See the chart for suggested shelf positions.

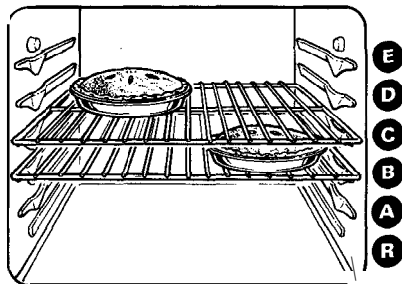

Type of Food	Shelf Position
Angel food cake	A
Biscuits or muffins	B or C
Cookies or cupcakes	B or C
Brownies	B or C
Layer cakes	B or C
Bundt or pound cakes	A or B
Pies or pie shells	B or C
Frozen pies	A (on cookie sheet)
Casseroles	B or C
Roasting	B or R

Preheating

Preheat the oven if the recipe calls for it. Preheat means bringing the oven up to the specified temperature before putting in the food. To preheat, set the oven at the correct temperature—selecting a higher temperature does not shorten preheat time.

Preheating is necessary for good results when baking cakes, cookies, pastry and breads. For most casseroles and roasts, preheating is not necessary. For ovens without a preheat indicator light or tone, preheat 10 minutes. After the oven is preheated place the food in the oven as quickly as possible to prevent heat from escaping.

Pan Placement

For even cooking and proper browning, there must be enough room for air circulation in the oven. Baking results will be better if baking pans are centered as much as possible rather than being placed to the front or to the back of the oven.

Pans should not touch each other or the walls of the oven. Allow 1 to 1 1/2 inch space between pans as well as from the back of the oven, the door and the sides. If you use two shelves, stagger the pans so one is not directly above the other.

(continued next page)



BAKING

(continued)

Baking Guides

When using prepared baking mixes, follow package recipe or instructions for best baking results.

Cookies

When baking cookies, flat cookie sheets (without sides) produce better-looking cookies. Cookies baked in a jelly roll pan (short sides all around) may have darker edges and pale or light browning may occur.

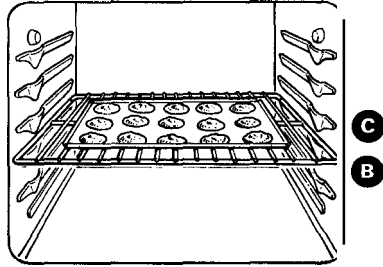

Do not use a cookie sheet so large that it touches the walls or the door of the oven. Never entirely cover a shelf with a large cookie sheet.

For best results, use only 1 cookie sheet in the oven at a time.

Aluminum Foil

Never entirely cover a shelf with aluminum foil. This will disturb the heat circulation and results in poor baking. A smaller sheet of foil may be used to catch a spillover by placing it on a lower shelf several inches below the food.

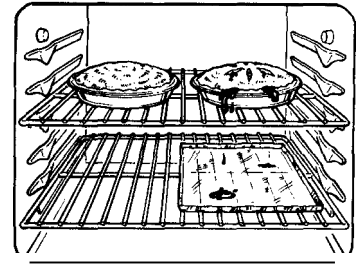

Pies

For best results, bake pies in dark, rough or dull pans to produce a browner, crisper crust. Frozen pies in foil pans should be placed on an aluminum cookie sheet for baking since the shiny foil pan reflects heat away from the pie crust; the cookie sheet helps retain it.

Cakes

When baking cakes, warped or bent pans will cause uneven baking results and poorly shaped products. A cake baked in a pan larger than the recipe recommends will usually be crisper, thinner and drier than it should be. If baked in a pan smaller than recommended, it may be undercooked and batter may overflow. Check the recipe to make sure the pan size used is the one recommended.

Baking Pans

Use the proper baking pan. The type of finish on the pan determines the amount of browning that will occur.

- Dark, rough or dull pans absorb heat resulting in a browner, crisper crust. Use this type for pies.
- Shiny, bright and smooth pans reflect heat, resulting in a lighter, more delicate browning. Cakes and cookies require this type of pan.
- Glass baking dishes also absorb heat. When baking in glass baking dishes, lower the temperature by 25°F. and use the recommended cooking time in the recipe. This is not necessary when baking pies or casseroles.

Don't Peek

Set the timer for the estimated cooking time and do not open the door to look at your food. Most recipes provide minimum and maximum baking times such as "bake 30-40 minutes."

DO NOT open the door to check until the minimum time. Opening the oven door frequently during cooking allows heat to escape and makes baking times longer. Your baking results may also be affected.

ROASTING



Roasting is cooking by dry heat. Tender meat or poultry can be roasted uncovered in your oven. Roasting temperatures, which should be low and steady, keep spattering to a minimum.

The oven has a special low shelf (R) position just above the oven bottom. Use it when extra cooking space is needed, for example, when roasting a large turkey. The shelf is not designed to slide out at this position.

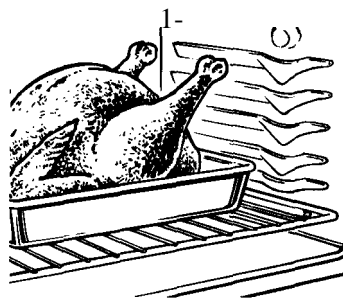

Roasting is really a baking procedure used for meats. Roasting is easy; just follow these steps:

1. Position oven shelf at (B) position for small size roast (3 to 5 lbs.) and at (R) position for larger roasts.

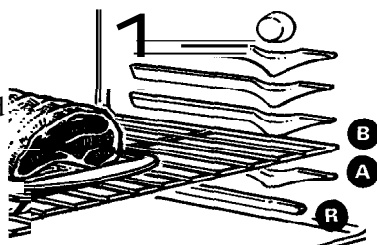

2. Check the weight of the meat. Place the meat fat-side-up or the poultry breast-side-up on the roasting rack in a shallow pan. The melting fat will baste the meat. Select a pan as close to the size of meat as possible. (Broiler pan with rack is a good pan for this.)

Line broiler pan with aluminum foil when using pan for marinating, cooking with fruits, cooking heavily cured meats, or basting food during cooking. Avoid spilling these materials inside the oven or inside the oven door.

3. If your model has a separate **BAKE/BROIL** switch, turn it to **BAKE**. Turn the **OVEN CONTROL** knob to desired temperature. Check the Roasting Guide for temperatures and approximate cooking times.
4. Most meats continue to cook slightly while standing after being removed from the oven. Recommended standing time for roasts is 10 to 20 minutes. This allows roasts to firm up and makes them easier to carve. Internal temperature will rise about 5° to 10°F. If you wish to compensate for temperature rise, remove the roast from the oven when its internal temperature is 5° to 10°F less than temperature shown in the Roasting Guide.

NOTE: Remember that food will continue to cook in the hot oven and therefore should be removed when the desired internal temperature has been reached.

Frozen Roasts

- Frozen roasts of beef, pork, lamb, etc., can be started without thawing, but allow 15 to 25 minutes per pound additional time (15 minutes per pound for roasts under 5 pounds, more time for larger roasts).
- Thaw most frozen poultry before roasting to ensure even doneness. Some commercial frozen poultry can be cooked successfully without thawing. Follow directions given on package label.

Dual Shelf Cooking

This allows more than one food to be cooked at the same time. For example: While roasting a 20-lb. turkey on shelf position R, a second shelf (if so equipped) may be added on position D so that scalloped potatoes can be cooked at the same time. Calculate the total cooking time to enable both dishes to complete cooking at the same time. Allow 15-20 minutes of additional cooking time for the potatoes.

(continued next page)



ROASTING

(continued)

Questions and Answers

- Q. Is it necessary to check for doneness with a meat thermometer?
- A. Checking the finished internal temperature at the completion of cooking time is recommended. Temperatures are shown in Roasting Guide. For roasts over 8 lbs., check with thermometer at half-hour intervals after half the time has passed.
- Q. Why is my roast crumbling when I try to carve it?
- A. Roasts are easier to slice if allowed to cool 10 to 20 minutes after removing them from the oven. Be sure to cut across the grain of the meat.
- Q. Do I need to preheat my oven each time I cook a roast or poultry?
- A. It is unnecessary to preheat your oven.
- Q. When buying a roast, are there any special tips that would help me cook it more evenly?
- A. Yes. Buy a roast as even in thickness as possible, or buy rolled roasts.
- Q. Can I seal the sides of my foil “tent” when roasting a turkey?
- A. Sealing the foil will steam the meat. Leaving it unsealed allows the air to circulate and brown the meat.

ROASTING GUIDE

Type	Oven Temperature	Doneness	Approximate Roasting Time in Minutes per Pound		Internal Temperature °F.
Meat Tender cuts; rib, high quality sirloir tip, rump or top round*	325°	Rare: Medium: Well Done:	3 to 5 lbs. 24-35 35-39 39-45	6 to 8 lbs. 18-25 25-31 31-33	140°-1500. 150°-1600 170°-1850
Lamb leg or bone-in shoulder*	325°	Rare: Medium: Well Done:	21-25 25-30 30-35	20-23 24-28 28-33	140°-150°. 150°-1600 170°-1850
Veal shoulder, leg or loin*	325°	Well Done:	35-45	30-40	170°-1800
Pork loin, rib or shoulder*	325°	Well Done:	35-45	30-40	170°-1800
Ham, precooked	325°	To Warm:	18-23 minutes per pound (any weight)		115°-1250
Poultry					
Chicken or Duck	325°	Well Done:	3 to 5 lbs. 35-40	Over 5 lbs. 30-35	185°-1900
Chicken pieces	350°	Well Done:	35-40		185°-1900
Turkey	325°	Well Done:	10 to 15 lbs. 16-22	Over 15 lbs 12-19	In thigh: 185°-1900

*For boneless rolled roasts over 6 inches thick, add 5 to 10 minutes per pound to times given above.

†The U.S. Department of Agriculture says “Rare beef is popular, but you should know that cooking it to only 140°F. means some food poisoning organisms may survive.” (Source: Safe Food Book, Your Kitchen Guide. USDA Rev. June 1985.)

BROILING



How to Broil

Broiling is cooking food by direct heat from above the food. Your range has either a broiler in the oven or a compartment below the oven for broiling. A specially designed broiler pan and rack allows dripping fat to drain away from the foods and be kept away from the high heat of the gas flame.

Both the oven and **broiler** compartment doors (on some models) should be closed during broiling.

Depending on whether your range is equipped with a separate broiler drawer or is equipped for in-oven broiling, you can change the distance of the food from the heat source by positioning the broiler pan and rack on one of the oven shelves or one of the three shelf positions in the broiler compartment-A (bottom of broiler compartment), B (middle) and C (top).

1. Preheating the broiler or oven is not necessary and can produce poor results.
2. If the meat has fat or gristle near the edge, cut vertical slashes through it about 2 inches apart, but don't cut into meat. We recommend that you trim fat to prevent excessive smoking, leaving a layer about 1/8 inch thick.

3. Arrange the food on the rack and position the broiler pan on the appropriate shelf in the oven or broiling compartment. Placing food closer to the flame increases exterior browning of food, but also increases spattering and the possibility of fats and meat juices igniting.
4. Close the oven or broiler door.
5. Turn the OVEN CONTROL knob and the BAKE/BROIL switch (on some models) to BROIL.
6. Turn most foods once during cooking (the exception is thin fillets of fish; oil one side, place that side down on broiler rack and cook without turning until done). Time foods for about one-half the total cooking time, turn food, then continue to cook to preferred doneness.
7. Turn the OVEN CONTROL knob to OFF. Remove the broiler pan from the oven and serve food immediately. Leave the pan outside the oven to cool.

Use of Aluminum Foil

You can use aluminum foil to line your broiler pan and broiler rack. However, you must mold the foil tightly to the rack and cut slits in it just like the rack.



Without the slits, the foil will prevent fat and meat juices from draining to the broiler pan. The juices could become hot enough to catch on fire. If you do not cut the slits, you are frying, not broiling.

Broiling Tips

1. Always use broiler pan and rack that comes with your oven. It is designed to minimize smoking and spattering by trapping juices in the shielded lower part of the pan.
2. For steaks and chops, slash fat evenly around outside edges of meat. To slash, cut crosswise through outer fat surface just to the edge of the meat. Use tongs to turn meat over to prevent piercing meat and losing juices.

Questions & Answers

Q. When broiling, is it necessary to always use a rack in the pan?

A. Yes. Using the rack suspends the meat over the pan. As the meat cooks, the juices fall into the pan, thus keeping meat drier. Juices are protected by the rack and stay cooler, thus preventing excessive spatter and smoking.

Q. Why are my meats not turning out as brown as they should?

A. Check to see if you are using the recommended shelf position. Broil for longest period of time indicated in the Broiling Guide, Turn food only once during broiling.

Q. **Should** I salt the meat before broiling?

A. No. Salt draws out the juices and allows them to evaporate. Always salt after cooking. Turn meat with tongs; piercing meat with a fork also allows juices to escape. When broiling poultry or fish, brush each side often with butter.

(continued next page)



BROILING GUIDE

Food	Quantity and/or Thickness	Models without Broiler Compartment			Models with Broiler Compartment			Comments
		Oven Shel Position	1st Side Minutes	2nd Side Minutes	Broiler Shel Position	1st Side Minute	2nd Side Minutes	
Bacon	1/2 lb. (about 8 thin slices)	C	3½	3	B	3½	3	Arrange in single layer.
Ground Beef	1 lb. (4 patties) 1/2 to 3/4 in. thick	C	10-11	4-5	A	10-11	4-5	Space evenly. Up to 9 patties take about same time.
Beef Steaks Rare Medium Well Done	1 in. thick (1 to 1½ lbs.)	B B B	9 12 13	7 5-6 8-9	B B A	9 12 13	7 5-6 8-9	Steaks less than 1 inch thick cook through before browning. Pan frying is recommended.
Rare Medium Well Done	1 in. thick (2 to 2½ lbs.)	B B B	10 12-15 25	6-7 9-12 16-18	B, C B A	10 12-15 25	6-7 10-12 16-18	Slash fat.
Chicken	1 whole (2 to 2½ lbs.), split lengthwise	B	30-35	25-30	A	30-35	25-30	Reduce times about 5 to 10 minutes per side for cut-up chicken. Brush each side with melted butter. Broil skin-side-down first.
Bakery Products Bread (Toast) or Toaster Pastries	2 to 4 slices 1 pkg. (2)	c	2-3	1/2-1	C	2-3	1/2-1	Space evenly. Place English muffins cut-side-up and brush with butter if desired.
English Muffins	2, split	c	3-5		C	3-5		
Loxster Tails	2 to 4 (6 to 8 oz. each)	C	13-16	Do not turn over.	A	13-16	Do not urn over.	Cut through back of shell and spread open. Brush with melted butter before broiling and after half of time.
Fish	1-lb. fillets 1/4 to 1/2 in. thick	B	5	5	B, C	5	5	Handle and turn very carefully. Brush with lemon butter before broiling and during broiling if desired. Preheat broiler to increase browning.
Ham Slices Precooked	1 in. thick	C	8	8	B	8	8	Increase 5 to 10 minutes per side for inch thick or home cured.
Pork Chops Well Done	2 (1/2 in. thick) 2(1 in. thick), about 1 lb.	B B	10 13	4-5 9-12	B B	10 13	4-5 9-12	Slash fat.
Lamb Chops Medium Well Done Medium Well Done	2(1 in.), 10 to 12 oz. 2 (1½ in.), about 1 lb.	B B B B	8 10 10 17	4-7 10 4-6 12-14	B B B B	8 10 10 17	4-7 10 4-6 12-14	Slash fat.
Wieners similar precooked sausages, bratwurs	1-lb. pkg. (10)	C	6	1-2	B, C	6	1-2	[f desired, split sausages n half lengthwise; cut nto 5- to 6-inch pieces.

CARE AND CLEANING

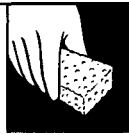

Proper care and cleaning are important so your range will give you efficient and satisfactory service. Follow these directions carefully in caring for it to help assure safe and proper maintenance.

BE SURE ELECTRICAL POWER IS DISCONNECTED BEFORE CLEANING ANY PART OF YOUR RANGE.

CAUTION: DO NOT OPERATE THE BURNER WITHOUT ALL BURNER PARTS AND DRIP PANS (IF SO EQUIPPED) IN PLACE.

Sealed Burner Assemblies (on some models)

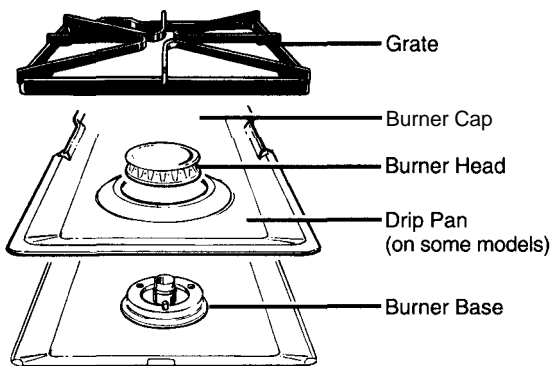

Turn all controls OFF before removing burner parts and drip pans (if so equipped).

The burner grates, caps, burner heads and drip pans (if so equipped) can be lifted off, making them easy to clean.

The electrode of the spark igniter is exposed. When one burner is turned to LITE, all the burners spark. Do not attempt to disassemble or clean around any burner while another burner is on. An electric shock may result, which could cause you to knock over hot cookware.

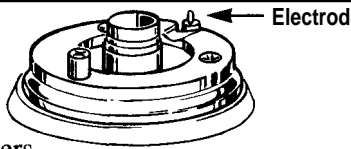

The holes in the surface burners of your range must be kept clean at all times for proper ignition and an even, unhampered flame.

You should clean the surface burners routinely, especially after bad **spillovers**, which could clog these holes. Wipe off surface burners. If heavy spillover occurs, remove the surface burners from range. Burners lift out for cleaning. Lift up the cooktop and then lift out the surface burners.

To remove burned-on food, soak the surface burner in a solution of mild liquid detergent and hot water. Soak the surface burner for 20 to 30 minutes. For more stubborn stains, use a cleanser like Soft Scrub® brand or Bon Ami® brand. Rinse well to remove any traces of the cleanser that might clog the surface burner openings. Do not use steel wool because it will clog the surface burner openings and scratch the surface burners. If the holes become clogged, clean them with a toothpick.

Before putting the surface burner back, shake out excess water and then dry it thoroughly by setting it in a warm oven for 30 minutes. Then place it back in the range, making sure it is properly seated and level.

Burner Caps (on sealed burners only)

Lift off when cool. Wash burner caps in hot, soapy water and rinse with clean water. If desired, soak up to 30 minutes and scour with a plastic scouring pad to remove burned-on food particles. Dry them in a warm oven or with a cloth—don't reassemble them wet.



Burner Base (on sealed burners only)

The burner base (the part of the burner fastened to the cooktop) may be cleaned with a soft brush and a mild cleanser. Clean all food residues from around spark electrode. Do not use steel wool; small bits of steel wool will short out the electrode. Rinse well.

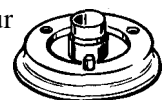

(continued next page)



CARE AND CLEANING

(continued)

Burner Heads (on sealed burners only)

The holes in the burners of your range, and the spark electrodes, must be kept clean at all times for proper ignition and an even, unhampered flame.



You **should** clean the burner heads routinely, especially after bad **spillovers**, which could clog these holes. Wipe off burner heads. If heavy **spillover** occurs, remove burner heads from range.

Remove the burner grate and burner cap. Then lift the burner head straight up.

To get rid of burned-on food, soak the burner head upside-down in a solution of mild liquid detergent and hot water. Soak the burner head for 20 to 30 minutes. If the food doesn't rinse off completely, scrub it with soap and water and a soft brush or plastic scouring pad.

For more stubborn stains, use a cleanser like Soft Scrub® brand or Bon Ami® brand. Rinse well to remove any traces of the cleanser that might clog the burner openings. Do not use steel wool because it will clog the burner openings and scratch the burners. If the holes become clogged, clean them with a toothpick. Before putting the burner **head** back, shake out excess water and dry it thoroughly by setting it in a warm oven for 30 minutes. Then place it back in the range, making sure the pin in the burner base goes in the hole in the burner head, and that the burner heads are properly seated and level.

CAUTION: DO NOT OPERATE THE BURNER WITHOUT ALL BURNER PARTS AND DRIP PANS (IF SO EQUIPPED) IN PLACE.

Dual Burners (on some models)

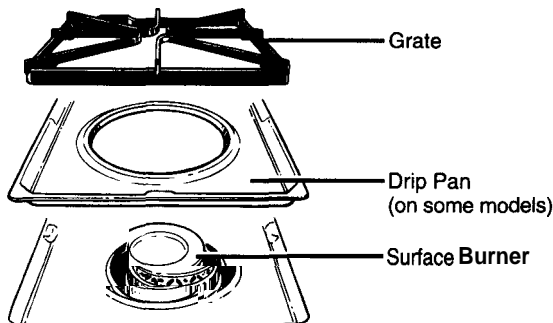

On models with dual burners, the **cooktop** lifts up for easy access.

Turn all controls OFF before removing burner parts and drip pans (if so equipped).

The burner grates and drip pans (if so equipped) can be lifted off, making them easy to clean.

The holes in the surface burners of your range must be kept clean at all times for proper ignition and an even, unhampered flame.

You should clean the surface burners routinely, especially after bad **spillovers**, which could clog these holes. Wipe off surface burners. If heavy **spillover** occurs, remove the surface burners from range. Burners lift out for cleaning. Lift up the **cooktop** and then lift out the surface burners.

To remove burned-on food, soak the surface burner in a solution of mild liquid detergent and hot water. Soak the surface burner for 20 to 30 minutes. For more stubborn stains, use a cleanser like Soft Scrub® brand or Bon Ami® brand. Rinse well to remove any traces of the cleanser that might clog the surface burner openings. Do not use steel wool because it will clog the surface burner openings and scratch the surface burners. If the holes become clogged, clean them with a toothpick.

Before putting the surface burner back, shake out excess water and then dry it thoroughly by setting it in a warm oven for 30 minutes. Then place it back in the range, making sure it is properly seated and level.

Drip Pans (on some models)

Remove the grates and lift out the drip pans. Drip pans can be cleaned in dishwasher or by hand.

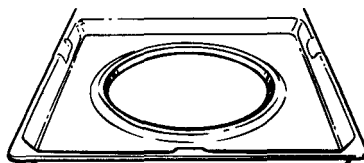

To get rid of burned-on food, place them in a covered container (or plastic bag) with 1/4 cup ammonia to loosen the soil. Then scrub with a soap-filled scouring pad if necessary.

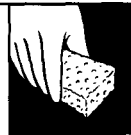

Burner Grates

Lift out when cool. Grates should be washed regularly and, of course, after **spillovers**.



Wash them in hot, soapy water and rinse with clean water. After cleaning, dry them thoroughly by putting them in a warm oven for a few minutes. Don't put the grates back on the range while they are wet. When replacing the grates, be sure they're positioned securely over the burners.

To prevent rusting on cast iron grates, apply a light coating of cooking oil on the bottom of the grates.

To get rid of burned-on food, place the grates in a covered container (or plastic bag) with 1/4 cup ammonia to loosen the soil. Then scrub with a soap-filled scouring pad if necessary.

Although they're durable, the grates will gradually lose their shine, regardless of the best care you can give them. This is due to their continual exposure to high temperatures.

Do not operate a burner for an extended period of time without cookware on the grate. The finish on the grate may chip without cookware to absorb the heat.

Cooktop Surface

To avoid damaging the porcelain enamel surface (on some models) of the **cooktop** and to prevent it from becoming dull, clean up spills right away. Food with a lot of acid (tomatoes, sauerkraut, fruit juices, etc.) or foods with high sugar content could cause a dull spot if allowed to set.

When the surface has cooled, wash and rinse. For other spills such as fat smatterings, etc., wash with soap and water once the surface has cooled. Then rinse and polish with a dry cloth. Be careful when you clean the cooktop because the area over the pilot will be hot (on models with standing pilots).

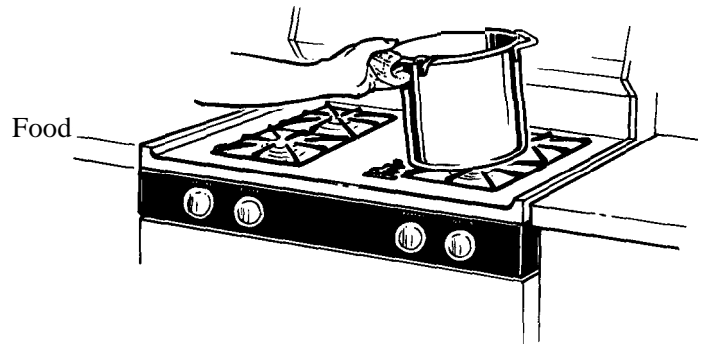

Do not store flammable materials in an oven or near the **cooktop**. Do not store or use combustible materials, gasoline or other flammable vapors and liquids in the vicinity of this or any other appliance.

Oven Bottom

The oven bottom has a porcelain enamel finish. To make cleaning easier, protect the oven bottom from excessive **spillovers** by placing a cookie sheet on the shelf below the shelf you are cooking on. You can use aluminum foil if you do not cover the whole shelf. This is particularly important when baking a fruit pie or other foods with a high acid content. Hot fruit fillings or other foods that are highly acidic (such as milk, tomatoes or sauerkraut, and sauces with vinegar or lemon juice) may cause pitting and damage to the porcelain enamel surface and should be wiped up immediately. Take care not to touch hot portion of oven.

If a **spillover** does occur on the oven bottom, allow the oven to cool first. You can then clean the oven bottom with soap and water, an abrasive cleanser or scouring pads.

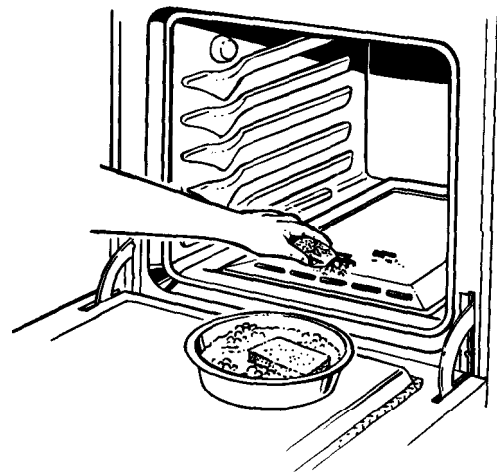

(continued next page)



CARE AND CLEANING

(continued)

Broiler Pan and Rack

After broiling, remove the broiler pan and rack from the oven. Remove the rack from the pan. Carefully pour out the grease in the pan into a proper container.

If food has burned on, sprinkle the rack with detergent while hot and cover with wet paper towels or a dishcloth. That way, burned-on foods will soak loose while the meal is being served.

Wash; scour if necessary. Rinse and dry. The broiler pan and rack may also be cleaned in a dishwasher. Do not store a soiled broiler pan and rack anywhere in the range.

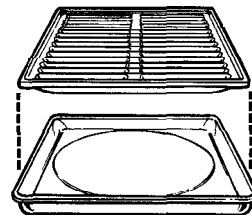

Oven Shelves

Shelves can be cleaned by hand using soap and water



or with an abrasive cleanser. After cleaning, rinse the shelves with clean water and dry. To remove heavy, burned-on soil, you may use scouring pads. After scrubbing, wash with soapy water, rinse and dry.

Oven Light Bulb (on some models)

The light bulb is located in the upper left corner (may vary) of

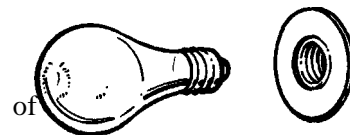

the oven. Before replacing the bulb, disconnect electrical power to range at the main fuse or circuit breaker panel or unplug the range from the electrical outlet. Let the bulb cool completely before removing it. Replace the bulb with a 40 watt appliance bulb only. Do not touch a hot bulb with a damp cloth as the bulb will break.

Control Panel and Knobs

It's a good idea to wipe the control panel after each use of the oven. Clean with mild soap and water or vinegar and water, rinse with clean water and polish dry with a soft cloth.

Do not use abrasive cleansers, strong liquid cleaners, plastic scouring pads or oven cleaners on the control panel—they will damage the finish. A 50/50 solution of vinegar and hot water works well.

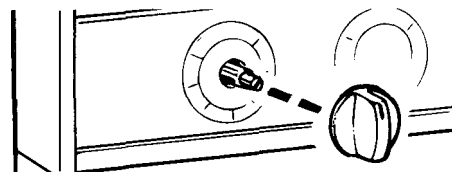

The control knobs may be removed for easier cleaning. To remove a knob, pull it straight off the stem. If the knob is difficult to remove, place a towel or dishcloth between the knob and control panel and pull gently. Wash the knobs in soap and water or a vinegar and hot water solution but do not soak.

Lift-Up Cooktop (on models with dual burners)

Clean the area under the cooktop often. Built-up soil, especially grease, may catch on fire.

To make cleaning easier, the cooktop may be lifted up.

To raise the cooktop:

1. Be sure the burners are turned off.
2. Remove the grates.
3. Grasp the 2 front burner wells and lift up.

Some models have dual support rods that will hold the cooktop up while you clean underneath it.

After cleaning under the cooktop with hot, soapy water and a clean cloth, lower the cooktop. Be careful not to pinch your fingers.

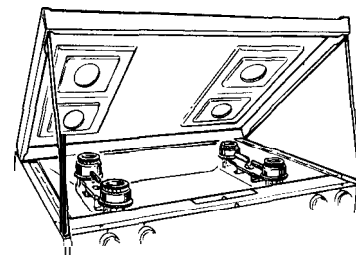

Lower the cooktop gently to avoid blowing out pilot flames (on models with standing pilots).

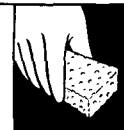

Oven Door

The oven door is removable but it is heavy. You may need help removing and replacing the door. Do not lift the door by the handle. This can cause the glass to break or damage to the door.

To remove the door, open it a few inches to the special stop position that will hold the door open, Grasp firmly on each side and lift the door straight up and off the hinges.

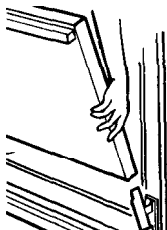

NOTE: Be careful not to place hands between the hinge and the oven door frame as the hinge could snap back and pinch fingers.

To replace the door, make sure the hinges are in the special stop position. Position the slots in the bottom of the door squarely over the hinges. Then lower the door slowly and evenly over both hinges at the same time. If hinges snap back against the oven frame, pull them back out.

TO CLEAN THE DOOR:
(Do not immerse the door in water.)

Inside of door:

- Allow to cool before cleaning. For light soil, wipe frequently with mild soap and water (especially after cooking meat). This will prolong the time between major cleaning. Rinse thoroughly.
- NOTE: **Soap** left on the oven door **causes additional stains** when the oven is reheated.

- For heavy soil, choose an oven cleaner (for Continuous Cleaning oven, before applying commercial oven cleaner, remove the oven door) and follow label instructions. Rinse well.

Outside of door:

- Use soap and water to thoroughly clean the top, sides and front of the oven door. Rinse well. You may also use a glass cleaner to clean the glass on the outside of the door.
- Spillage of marinades, fruit juices, tomato sauces and basting materials containing acids may cause discoloration and should be wiped up immediately. When surface is cool, clean and rinse.
- Do not use oven cleaners, cleansing powders or harsh abrasives on the outside of the door.

Porcelain Oven Interior (on all models except Continuous-Cleaning models)

With proper care, the porcelain enamel interior will retain its attractive finish for many years.

Soap and water will normally do the job. Heavy spattering or spillovers may require cleaning with a mild abrasive cleanser. Soapy, wet pads may also be used. Do not allow food spills with a high sugar or acid content (such as milk, tomatoes, sauerkraut, fruit juices or pie filling) to remain on the surface. They may cause dull spots even after cleaning.

Household ammonia may make the cleaning job easier. Place 1/2 cup ammonia in a shallow glass pan and leave in a cold oven overnight. The ammonia fumes will help loosen the burned-on grease and food.

When necessary, you may use a commercial oven cleaner. Follow the package directions.

Cautions about using spray-on oven cleaners:

- Be careful where the oven cleaner is sprayed.
- Do not spray oven cleaner on the electrical controls and switches (on some models) because it could cause a short circuit and result in sparking or fire.
- Do not allow a film from the cleaner to remain on the temperature sensing bulb—it could cause the oven to heat improperly. (The bulb is located at the rear of the oven.) Carefully wipe the bulb clean after each oven cleaning, being careful not to move the bulb as a change in its position could affect how the oven bakes.
- Do not spray any oven cleaner on the outside oven door, handles or any exterior surface of the oven, wood or painted surfaces. The cleaner can damage these surfaces.

Oven Air Vents

Never block the vents (air openings) of the range. They provide the air inlet and outlet that are necessary for the range to operate properly with correct combustion.

Air openings are located at the rear of the cooktop, at the top and bottom of the oven door, and at the bottom of the range, under the kick panel, storage drawer or broiler drawer (depending on the model).

(continued next page)



CARE AND CLEANING

(continued)

Special Care of Continuous-Cleaning Oven Interior (on some models)

The Continuous-Cleaning Oven cleans itself while cooking. The oven walls are finished with a *special coating* that cannot be cleaned in the usual manner with soap, detergents, steel wool pads, commercial oven cleaners, coarse abrasive pads or coarse brushes. Use of such cleansers and/or the use of oven sprays will cause permanent damage.

The special coating is a porous ceramic material, which is dark in color and feels slightly rough to the touch. If magnified, the surface would appear as peaks, valleys and sub-surface “tunnels.” This rough finish tends to prevent grease splatters from forming little beads or droplets that run down the side walls of a hard-surface oven liner, leaving unsightly streaks that require hand cleaning. Instead, when spatter hits the porous finish, it is dispersed and partially absorbed. This spreading action increases the exposure of oven soil to heated air and makes it somewhat less noticeable.

Soil may not **disappear** completely and at some time after extended usage, stains may appear that cannot be removed.

This special coating works best on small amounts of spatter. It does not work well with larger spills, especially sugars, egg or dairy mixtures. The oven bottom does not have the continuous cleaning oven coating and can be removed and cleaned with a commercial oven cleaner.

This special coating is not used on oven shelves, the oven bottom or on the inside of the oven door. Remove these to clean with a commercial oven cleaner to prevent damaging the Continuous-Cleaning Oven coating.

Make sure the oven bottom is in place before you turn the oven on for any reason.

Use care in removing and replacing the oven bottom and shelves and in placing and removing dishes and food to avoid scratching, rubbing or otherwise damaging the porous finish on the oven walls.

To Clean the Continuous-Cleaning Oven:

1. Let range parts cool before handling. We recommend rubber gloves be worn when cleaning.
2. Remove the shelves and cookware.
3. Soil visibility maybe reduced by operating the oven at 400°F. Close the door and turn the OVEN CONTROL knob to 400°F. Time for at least 4 hours. Repeated cycles may be necessary before improvement in appearance is apparent.

Remember: During the operation of the oven, the door and other range surfaces will get hot enough to cause burns. Do not touch. Let the range **cool** before replacing oven shelves.

4. If a spillover or heavy soiling occurs on the porous surface, as soon as the oven has cooled, remove as much of the soil as possible using a small amount of water and a stiff-bristle nylon brush. Use water sparingly and change it frequently, keeping it as clean as possible, and be sure to blot it up with paper towels, cloths or sponges. Do not rub or scrub with paper towels, cloths or sponges, since they will leave unsightly lint on the oven finish. If water leaves a white ring on the finish as it dries, apply water again and blot it with a clean sponge, starting at the edge of the ring and working toward the center.

Do not use soap, detergent, steel wool pads, commercial oven cleaner, silicone oven sprays, coarse pads or coarse brushes on the porous surface. These products will spot, clog and damage the porous surface and reduce its ability to work.

Do not scrape the **porous** surface with a knife or spatula— they could permanently damage the finish.

The oven bottom has a porcelain enamel finish. The oven bottom comes out for cleaning away from the Continuous-Cleaning Oven.

The inside of the oven door has a porcelain enamel finish. The oven door lifts off for cleaning away from the Continuous-Cleaning Oven. For instructions on how to clean the inside of the oven door refer to the Oven Door section.

Metal Parts

Do not use steel wool, abrasives, ammonia or commercial oven cleaners. To safely clean surfaces; wash, rinse and then dry with a soft cloth.

Glass Surfaces

To clean the outside glass finish, use a glass cleaner. Rinse and polish with a dry cloth. Do not allow the water or cleaner to run down inside openings in the top of the oven door while cleaning.

Painted Surfaces

Painted surfaces include the outside oven door, sides, control panel and drawer front. Clean these with soap and water or a vinegar and water solution. Do not use commercial oven cleaners, cleansing powders, steel wool or harsh abrasives on any painted surface.

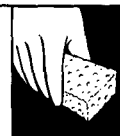

Removable Storage Drawer (on some models)

The storage drawer is a good place to store cookware and bakeware. Do not store plastics and flammable material in the drawer.

Do not overload the storage drawer. If the drawer is too heavy, it may slip off the track when opened.

The storage drawer may be removed for cleaning under the range. Clean the storage drawer with a damp cloth or sponge. Never use harsh abrasives or scouring pads.

To remove storage drawer:

1. Pull the drawer straight out until it stops.
2. Lift the drawer until it stops on the drawer clear stops on the range.
3. Again pull the drawer out until it hits the second set of stops.
4. Tilt the front of the drawer up and free of range.

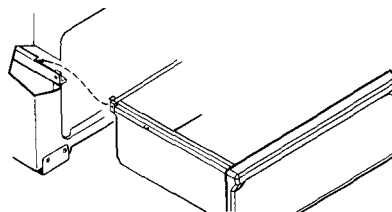

To replace storage drawer:

1. Set the stops on the back of the drawer over the stops in the range.
2. Slide the drawer evenly and straight back, so that the rails in the range are engaged.
3. Push the drawer back until second stops on drawer hit the stops in the range. Tilt the drawer up and over these.
4. Slide the drawer in the rest of the way.

Removable Broiler Drawer (on some models)

To remove:

1. When the broiler is cool, remove rack and pan.
2. Pull the broiler drawer out until it stops, then push it back in about 1 inch.
3. Grasp handle, lift and pull broiler drawer out. Clean the broiler drawer with hot soapy water.



To replace:

1. Hold the broiler drawer in the raised position as you slide it partway into the range. Then lower the drawer and push it completely closed.

Removable Kick Panel (on some models)

The kick panel may be removed for cleaning under the range.

To remove, lift up bottom of panel slightly to disengage the panel from the tabs at the base of the range. Pull the bottom of the panel forward until spring clips are released at top of panel.

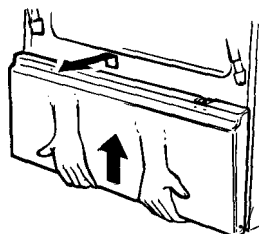

To replace, insert the 2 slots at bottom of panel onto the 2 tabs at base of the range and push the top of panel forward to engage spring clips.

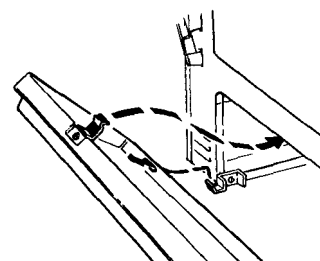

Air Adjustment Shutter(s) for Oven Burner(s)

The air adjustment shutter(s) for the oven burner(s) regulates the flow of air to the flames.

The location of the air adjustment shutter(s) depends on whether your oven has a single bottom burner or two separate burners—a top burner for broiling and a bottom burner for normal baking. See Installation Section of this book for instructions for location and proper adjustment of shutters.



INSTALLATION INSTRUCTIONS

FOR YOUR SAFETY

If you smell gas:

1. Open windows.
2. Don't touch electrical switches.
3. Extinguish any open flame.
4. Immediately call your gas supplier.

FOR YOUR SAFETY

Do not store or use combustible materials, gasoline or other flammable vapors and liquids in the vicinity of this or any other appliance.

BEFORE YOU BEGIN

Read these instructions completely and carefully.

IMPORTANT: Save these instructions for the local electrical inspector's use.

INSTALLER: Leave these instructions with the appliance tier installation is completed.

CONSUMER: Keep this Use and Care Guide and the Installation Instructions for future use.

This appliance must be properly grounded.

WARNING

Improper installation, adjustment, alteration, service or maintenance can cause injury or property damage. Refer to this manual. For assistance or additional information, consult a qualified installer, service agency, manufacturer (dealer) or the gas supplier.

CAUTION

Do not attempt to operate the oven of this range during a power failure.

IMPORTANT

Remove all packing material and literature from oven before connecting gas and electrical supply to range.

DIMENSIONS AND CLEARANCES

Provide adequate clearances between the range and adjacent combustible surfaces.

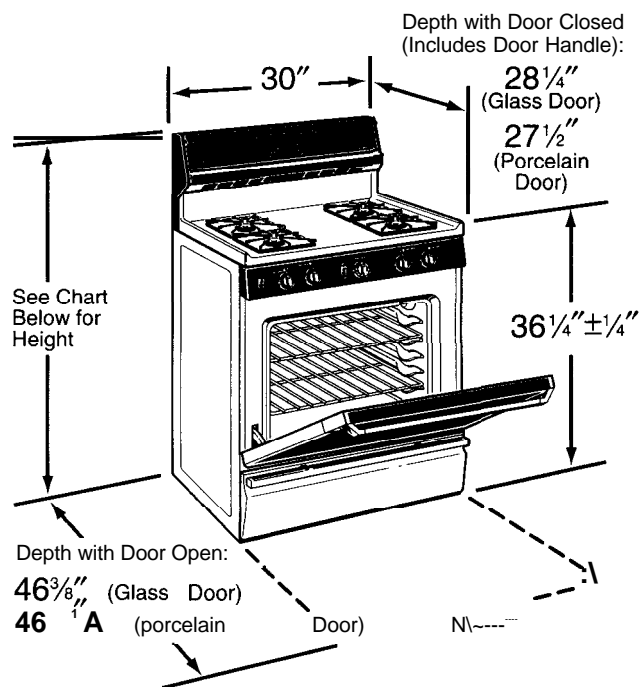

Range Height:

36"	JGSS05GER	JGSS05GES		
40"	JGBS02EN	JGBS02PN		
44"	JGBS04PR	JGBS04ER	JGBS04GER	JGBS04GPR
	JGBS06ER	JGBS06ES		
46 1/2"	JGBS12GER	JGBS15GER	JGBS16GEP	JGBS17GER
	JGBS14GES	JGBS18GES	JGBC16GEP	JGBC17GER
	JGBC15GER	JGBS19GEP		

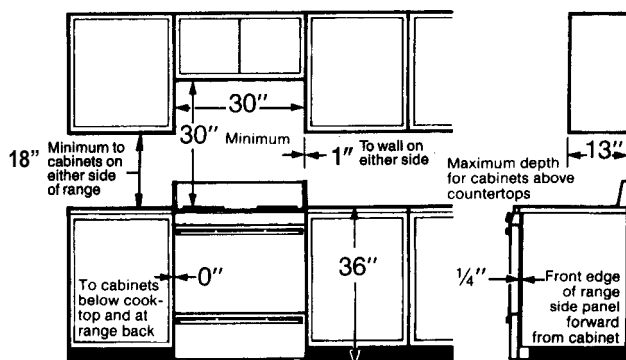



IMPORTANT SAFETY INSTRUCTIONS

Installation of this range must conform with local codes, or in the absence of local codes, with the National Fuel Gas Code, ANSI Z223.1, latest edition. In Canada, installation must conform with the current Natural Gas Installation Code, CAN/CGA-B149.1 or the current Propane Installation Code, CAN/CGA-B149.2, and with local codes where applicable.

This range has been design-certified by the American Gas Association according to ANSI Z21.1, latest edition and Canadian Gas Association according to CAN/CGA-1.1 latest edition. As with any appliance using gas and generating heat, there are certain safety precautions you should follow. You will find these precautions in the Important Safety Instructions in the front of this book. Read them carefully.

- Have your range installed by a qualified installer or service technician.

- Your range must be electrically grounded in accordance with local codes or, in the absence of local codes, in accordance with the National Electrical Code (ANSI/NFPA 70, latest edition). In Canada, electrical grounding must be in accordance with the current CSA C22.1 Canadian Electrical Code Part 1 and/or local codes. See Electrical Connections in this section.

- Before installing your range on linoleum or any other synthetic floor covering, make sure the floor covering can withstand 180°F. without shrinking, warping or discoloring. Do not install the range over carpeting unless a sheet of 1/4" thick plywood or similar insulator is placed between the range and carpeting.

- Make sure the wall coverings around the range can withstand heat generated by the range up to 200° F.

- Avoid placing cabinets above the range. To reduce the hazard caused by reaching over the open flames of operating burners, install a ventilation hood over the range that projects forward at least 5" beyond the front of the cabinets.

- The ventilating hood must be constructed of sheet metal not less than 0.0122" thick. Install above the cooktop with a clearance of not less than 1/4" between the hood and the underside of the combustible material or metal cabinet. The hood must be at least as wide as the appliance and centered over the appliance.

Clearance between the cooking surface and the ventilation hood surface **MUST NEVER BE**

LESS THAN 24 INCHES. If cabinets are placed above the range, allow a minimum clearance of 30" between the cooking surface and the bottom of unprotected cabinets.

- If a 30" clearance between cooking surface and overhead combustible material or metal cabinets cannot be maintained, protect the underside of the cabinets above the cooktop with not less than 1/4" insulating millboard covered with sheet metal not less than 0.0122" thick.

- Clearance between the cooking surface and protected cabinets **MUST NEVER BE LESS THAN 24 INCHES**. The vertical distance from the plane of the cooking surface to the bottom of adjacent overhead cabinets extending closer than 1" to the plane of the range sides must not be less than 18". (See Dimensions and Clearances illustration in this section.)

- Caution: Items of interest to children should not be stored in cabinets above a range or on the backsplash of a range—children climbing on the range to reach items could be seriously injured.



WARNING

All ranges can tip and injury could result. To prevent accidental tipping of the range, attach an approved Anti-Tip device to the wall. (See Installing the Anti-Tip Device in this section.) To check if the device is installed and engaged properly, carefully tip the range forward. The

Anti-Tip device should engage and prevent the range from tipping over.

If you pull the range out from the wall for any reason, make sure the Anti-Tip device is engaged when you push the range back against the wall.

- For your safety, never use your range for warming or heating the room. Your oven and range top are not designed to heat your kitchen. Top burners should not be operated without cookware on the grate. Such abuse could result in fire and damage to your range and will void your warranty.

- Do not store or use combustible materials, gasoline or other flammable vapors and liquids in the vicinity of this or any other appliance. Explosions or fires could result.

- Do not use oven for a storage area. Items stored in the oven can ignite.

- Do not let cooking grease or other flammable materials accumulate in or near the range.



INSTALLATION INSTRUCTIONS

(continued)

GENERAL

. See Dimensions and Clearances in this section for all rough-in and spacing dimensions. These dimensions must be met for safe use of your range. The location of the electrical outlet and pipe opening (see Gas Pipe and Electric Outlet Locations) may be adjusted to meet specific requirements.

. The range may be placed with 0" clearance (flush) at the back wall and sidewalls of the range.

LOCATION

Do not locate the range where it may be subject to strong drafts. Any openings in the floor or wall behind the range should be sealed. Make sure the openings around the base of the range that supply fresh air for combustion and ventilation are not obstructed by carpeting or woodwork.

PROTECT YOUR FLOOR

Your range, like many other household items, is heavy and can settle into soft floor coverings such as cushioned vinyl or carpeting. Use care when moving the range on this type of flooring. It is recommended that the following simple and inexpensive instructions be followed to protect your floor.

The range should be installed on a sheet of plywood (or similar material). *When* the floor covering *ends at the front of the range*, the area that the range will rest on should be built up with plywood to the same level or higher than the floor covering. This will allow the range to be moved for cleaning or servicing.

MODEL AND SERIAL NUMBER LOCATION

Depending on your range, you'll find the model and serial numbers on a label on the front frame of the range, behind the storage drawer, kick panel or broiler drawer.

TOOLS YOU WILL NEED

- Phillips and flat-blade screwdrivers
- Pencil and ruler
- Two pipe wrenches (one for backup)
 - . 1%" open-end or adjustable wrench
- Nut drivers or wrenches: 3/16" and 1/4"

ADDITIONAL MATERIALS YOU MAY NEED

- Gas line shut-off valve
- Pipe joint sealant or UL-approved pipe thread tape with Teflon* that resists action of natural and LP gases
- Flexible metal appliance connector (1/2" I. D.)
A 5-foot length is recommended for ease of installation but other lengths are acceptable. Never use an old connector when installing a new range.
- Flare union adapter for connection to gas supply line (3/4" or 1/2" NPT x 1/2" I. D.)
- Flare union adapter for connection to pressure regulator on range (1/2" NPT x 1/2" I. D.)

*Teflon: Registered trademark of DuPont

PREPARATION

- . Remove all tape and packaging. Lift up the cooktop (on models with dual burners) and remove any packing material under it. Make sure the dual burners are properly seated and level.
- Remove plastic film that covers some chrome parts (around oven door, side trim).
- Take the accessory pack out of the oven.
- Check to be sure that no range parts have come loose during shipping.



PROVIDE ADEQUATE GAS SUPPLY

Your range is designed to operate at a pressure of 4" of water column on natural gas or, if designed for LP gas (propane or butane), 10" of water column. Make sure you are supplying your range with the type of gas for which it is designed. This range is convertible for use on natural or propane gas, if you decide to use this range on a different type of gas, conversion adjustments must be made by a service technician or other qualified person before attempting to operate the range on that gas.

For proper operation, the pressure of natural gas supplied to the regulator must be between 4" and 13" of water column. For LP gas, the pressure supplied must be between 10" and 13" of water column. When checking for proper operation of the regulator, the inlet pressure must be at least 1" greater than the operating (manifold) pressure as given above. The pressure regulator located at the inlet of the range manifold must remain in the supply line regardless of whether natural or LP gas is being used. A flexible metal appliance connector used to connect the range to the gas supply line should have an I.D. of 1/2" and be 5 feet in length for ease of installation. In Canada, flexible connectors must be single wall metal connectors no longer than 6 feet in length.

CONNECT THE RANGE TO GAS

Shut off the main gas supply valve before disconnecting the old range and leave it off until new hook-up has been completed. Don't forget to relight the pilot on other gas appliances when you turn the gas back on.

Because hard piping restricts movement of the range, the use of an A. G.A.-certified flexible metal appliance connector is recommended unless local codes require a hard-piped connection. Never use an old connector when installing a new range. If the hard piping method is used, you must carefully align the pipe; the range cannot be moved after the connection is made.

To prevent gas leaks, put pipe joint compound on, or wrap pipe thread tape with Teflon* around, all male (external) pipe threads.

*Teflon: Registered trademark of DuPont

Gas Pipe and Electric Outlet Locations for Models Equipped with Sealed Burners

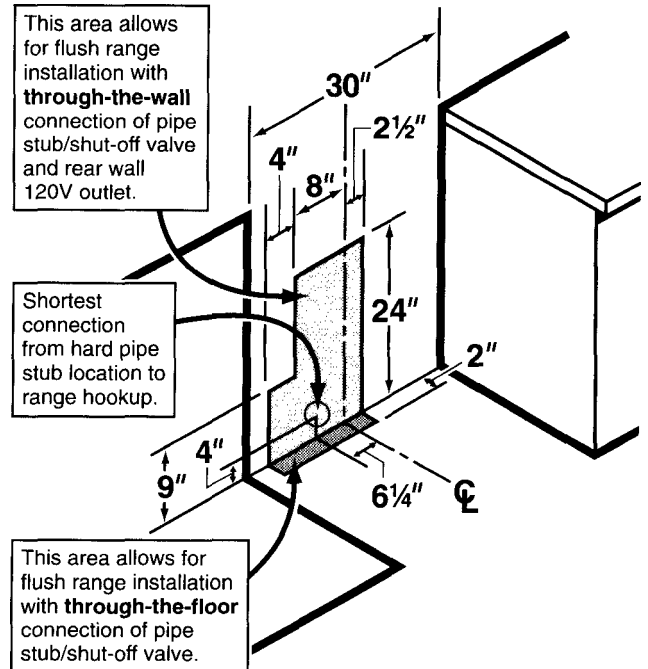

Gas Pipe and Electric Outlet Locations for Models Equipped with Dual Burners

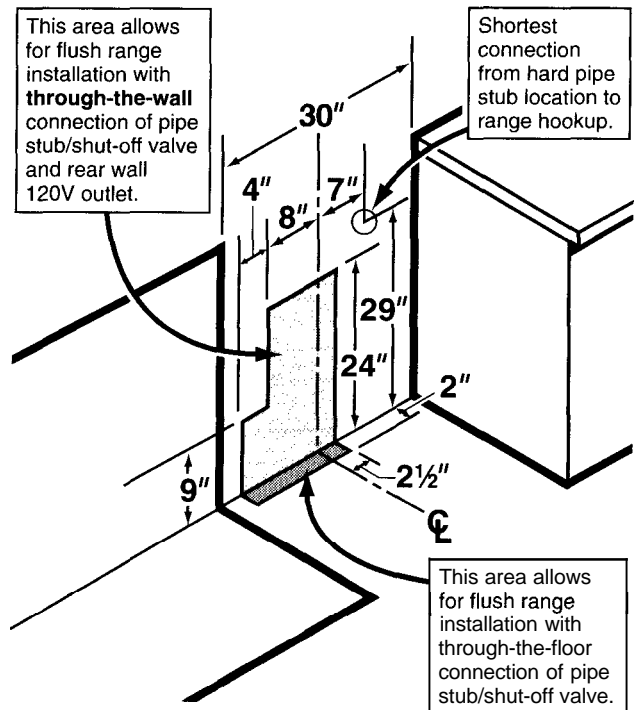

(continued next page)



INSTALLATION INSTRUCTIONS

(continued)

CONNECT THE RANGE TO GAS (continued)

Flexible Connector Hookup for Models Equipped with Sealed Burners

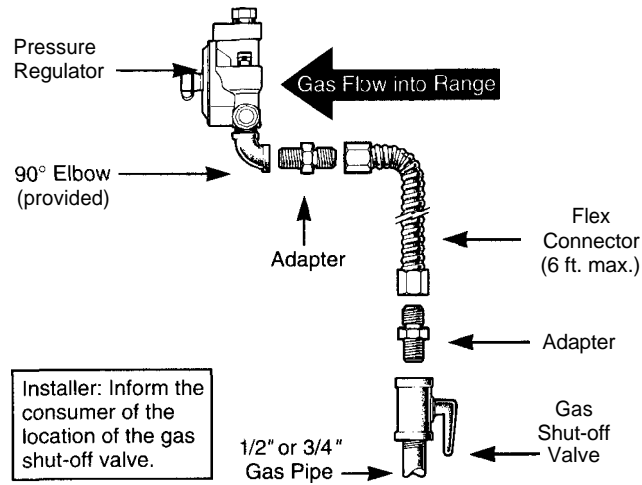

Rigid Pipe Hookup for Models Equipped with Sealed Burners

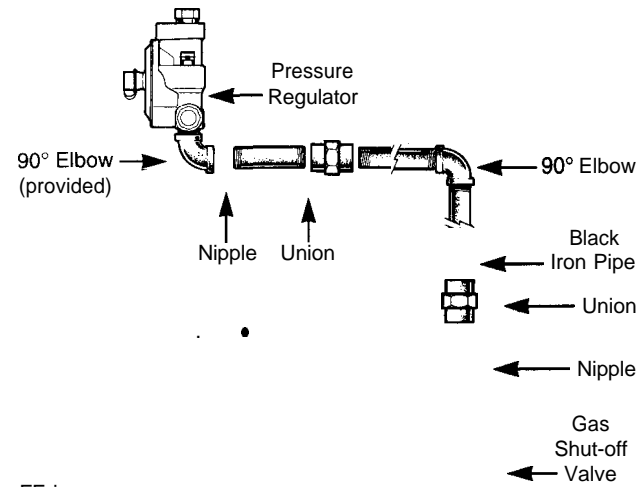

FE-i

Flexible Connector and Rigid Pipe Hookups for Models Equipped with Dual Burners

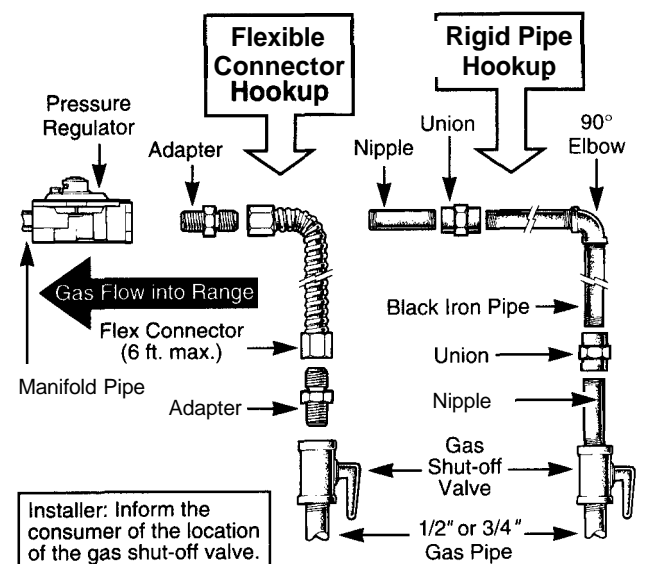



1. Install a manual gas line shut-off valve in the gas line in an easily accessed location outside of the range. Make sure everyone operating the range knows where and how to shut off the gas supply to the range.

2. Install male 1/2" flare union adapter to the 1/2" NPT internal thread elbow at inlet of regulator. On models equipped **with dual** burners, install the male pipe thread end of the 1/2" flare union adapter to the 1/2" NPT internal thread at inlet of pressure regulator. Use a backup wrench on the regulator fitting to avoid damage.

When installing the range from the front, remove the 90° elbow for easier installation.

3. Install male 1/2" or 3/4" flare union adapter to the NPT internal thread of the manual shut-off valve, taking care to back-up the shut-off valve to keep it from turning.

4. Connect flexible metal appliance connector to the adapter on the range. Position range to permit connection at the shut-off valve.

5. When all connections have been made, make sure all range controls are in the off position and turn on the main gas supply valve. Use a liquid leak detector at all joints and connections to check for leaks in the system.

CAUTION: DO NOT USE A FLAME TO CHECK FOR GAS LEAKS.

When using test pressures greater than 1/2 psig to pressure test the gas supply system of the residence, disconnect the range and individual shut-off valve from the gas supply piping. When using test pressures of 1/2 psig or less to test the gas supply system, simply isolate the range from the gas supply system by closing the individual shut-off valve.

ELECTRICAL CONNECTIONS

Electrical Requirements

120-volt, 60 Hertz, properly grounded branch circuit protected by a 15-amp or 20-amp circuit breaker or time delay fuse.

Extension Cord Cautions

Because of potential safety hazards associated with certain conditions, we strongly recommend against the use of an extension cord. However, if you still elect to use an extension cord, it is absolutely necessary that it be a UL-listed, 3-wire grounding-type appliance extension cord and that the current carrying rating of the cord in amperes be equivalent to, or greater than, the branch circuit rating.

Grounding

IMPORTANT—(Please read carefully)

FOR PERSONAL SAFETY, THIS APPLIANCE MUST BE PROPERLY GROUNDED.

The power cord of this appliance is equipped with a three-prong (grounding) plug which mates with a standard three-prong grounding

PREFERRED METHOD

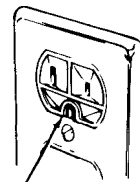

ENSURE PROPER GROUND EXISTS BEFORE USE

wall receptacle to minimize the possibility of electric shock hazard from this appliance.

The customer should have the wall receptacle and circuit checked by a

qualified electrician to make sure the receptacle is properly grounded.

Where a standard two-prong wall receptacle is encountered, it is the personal responsibility and obligation of the customer to have it replaced with a properly grounded three-prong wall receptacle. **DO NOT, UNDER ANY CIRCUMSTANCES, CUT OR REMOVE THE THIRD (GROUND) PRONG FROM THE POWER CORD.**

(continued next page)



INSTALLATION INSTRUCTIONS

(continued)

ELECTRICAL CONNECTIONS (continued)

Usage Situations where Appliance Power Cord will be Disconnected Infrequently.

An adapter may be used only on a 15-amp circuit. Do not use an adapter on a 20-amp circuit. Where local codes permit, a **TEMPORARY CONNECTION** may be made to a properly grounded two-prong wall receptacle by the use of a UL-listed adapter, available at most hardware stores. The larger slot in the adapter must be aligned with the larger slot in the wall receptacle to provide proper polarity in the connection of the power cord,

**TEMPORARY METHOD
(ADAPTER PLUGS NOT PERMITTED IN CANADA)**

ALIGN LARGE PRONGS/SLOTS

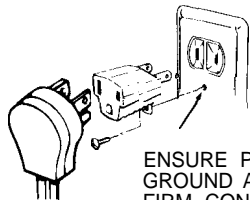

ENSURE PROPER GROUND AND FIRM CONNECTION BEFORE USE

CAUTION: Attaching the adapter ground terminal to the wall receptacle cover screw does not ground the appliance unless the cover screw is metal, and not insulated, and the wall receptacle is grounded through the house wiring. The customer should have the circuit checked by a qualified electrician to make sure the receptacle is properly grounded.

When disconnecting the power cord from the adapter, always hold the adapter with one hand. If this is not done, the adapter ground terminal is very likely to break with repeated use. Should this happen, **DO NOT USE** the appliance until a proper ground has again been established.

Usage Situations where Appliance Power Cord will be Disconnected Frequently.

Do not use an adapter plug in these situations because disconnecting of the power cord places undue strain on the adapter and leads to eventual failure of the adapter ground terminal. The customer should have the two-prong wall receptacle replaced with a three-prong (grounding) receptacle by a qualified electrician before using the appliance.

The installation of appliances designed for mobile home installation must conform with the Manufactured Home Construction and Safety Standard, Title 24 CFR, Part 3280 (formerly the Federal Standard for Mobile Home Construction and Safety, Title 24, HUD, Part 280) or, when such standard is not applicable, the Standard for Manufactured Home Installations, latest edition (Manufactured Home Sites, Communities and Set-Ups), ANSI A225.1, latest edition, or with local codes. In Canada, mobile home installation must be in accordance with the current CAN/CSA Z240/MH Mobile Home Installation Code.

Electric Disconnect

1. Locate disconnect plug on the range back.
2. Pinch sides of connector and pull out of range back.

You will have one of these disconnect plugs.

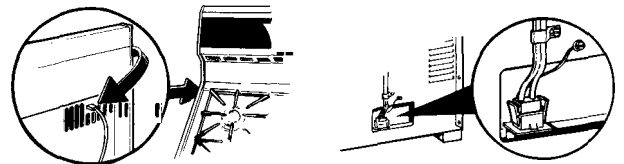



SEAL THE OPENINGS

Seal any openings in the wall behind the range and in the floor under the range when hookups are completed.

LIGHT THE PILOTS

(for Models Equipped with Standing Pilots)

The range should be installed in its permanent position before any pilots are lit or adjusted.

Light the Surface Burner Pilots

CAUTION: Make sure the surface burner control knobs are in the "OFF" positions before attempting to light the pilots.

1. Raise the cooktop.
2. Light both pilots with a match.
3. To avoid pilot outage, use caution when closing cooktop after lighting pilots.

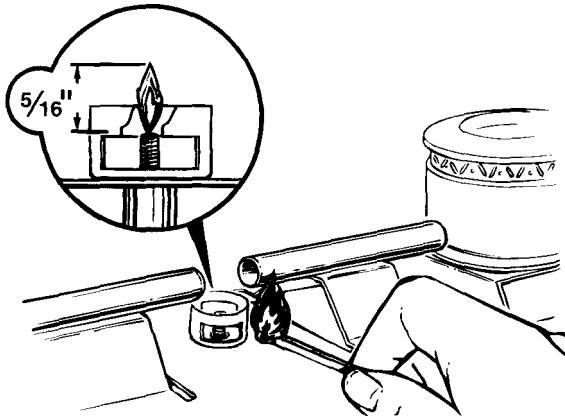

NOTE: Do not leave standing pilot lit in a newly constructed or remodeled home or apartment that will be unoccupied for more than a month. Each pilot flame was adjusted at the factory to be approximately 5/16" tall. A tinge of yellow appearing at the upper tip is normal. If you find pilot adjustment is necessary, follow instructions at right.

Adjust the Surface Burner Pilots if Necessary

1. Raise the cooktop.

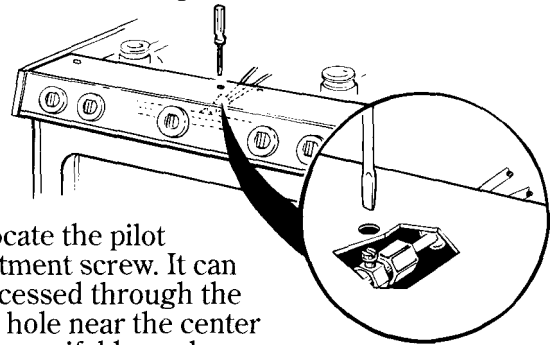

2. Locate the pilot adjustment screw. It can be accessed through the small hole near the center of the manifold panel.

3. To adjust, use a blade-type screwdriver with a shaft diameter of less than 3/16". Turn pilot adjustment screw until pilot is 5/16" high. Do not reduce the flame to less than 5/16" or pilot outage may occur. A pilot flame burning higher than recommended may generate soot (carbon black) on the bottom of your cooktop.

LIGHT THE OVEN PILOT

CAUTION: Make sure the OVEN CONTROL knob is in the "OFF" position before attempting to light the pilot.

1. Remove the broiler drawer by sliding the drawer all the way out and then lifting slightly to remove it from its tracks.

2. Locate the pilot at the back of the broiler compartment. The pilot is attached to the left side of the oven burner.
3. Light the pilot with a match. No adjustments are required for natural gas. For LP gas, see How to Convert the Range for Use with LP Gas or Natural Gas.

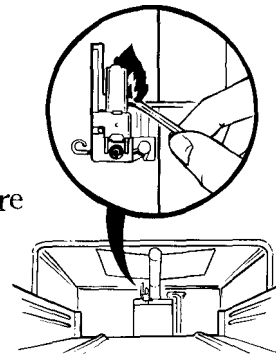

(continued next page)



INSTALLATION INSTRUCTIONS

(continued)

LIGHT THE PILOTS (continued)

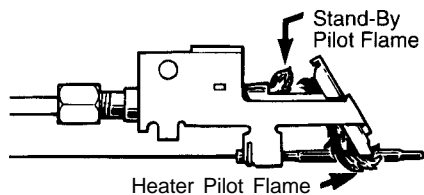

4. Turn the OVEN CONTROL knob to a setting above 200° F. The pilot flame will increase in size and impinge on the temperature-response element. The oven burner will light in 30-90 seconds.

The oven burner will operate until the set temperature is reached. The oven burner will continue to cycle on and off as necessary to maintain the oven at the temperature indicated by the OVEN CONTROL knob.

CHECK IGNITION OF SURFACE BURNERS

Surface Burner Ignition

Operation of all cooktop and oven burners should be checked after the pilots have been lighted (on some models) and range and gas supply lines have been carefully checked for leaks.

Standing Pilot Models

Select a top burner knob and simultaneously push in and turn to HI position. The burner should light within a few seconds. Try each burner in succession until all burners have been checked.

Electric Ignition Models

Select a top burner knob and simultaneously push in and turn to LITE position. You will hear a snapping sound indicating proper operation of the spark module. Once the air has been purged from the supply lines, burners should light within 4 seconds. After burner lights, rotate knob out of the LITE position. Try each burner in succession until all burners have been checked.

Quality of Flames

The combustion quality of burner flames needs to be determined visually.

If burner flames look like (A), call for service. Normal burner flames should look like (B) or (C), depending on the type of gas you use. With LP gas, some yellow tipping on outer cones is normal.



(A) **Yellow flames**—
Call for service

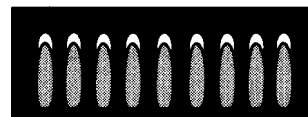

(B) **Yellow tips on outer cones**—
Normal for LP gas

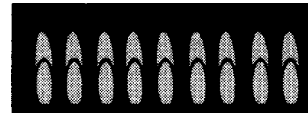

(C) **Soft blue flames**—
Normal for natural gas

Oven Burner Ignition

Your oven is designed to operate quietly and automatically. To operate the oven, turn the OVEN CONTROL knob to a setting above 200° F. After 30-90 seconds, the oven burner will ignite and burn until the set temperature is reached. The oven burner will continue to cycle on and off as necessary to maintain the oven at the temperature indicated by the OVEN CONTROL knob.

Electric ignition models require electrical power to operate. The oven cannot be lit during a power outage. Gas will not flow unless the glow bar is hot.

If the oven is in use when a power outage occurs, the burner will shut off and cannot be re-lit until power is restored.



ADJUST BROIL AND OVEN BURNER AIR ADJUSTMENT SHUTTERS ON A MODEL WITH A STORAGE DRAWER, IF NECESSARY (See Step 9 if your range is equipped with a broiler drawer.)

Air adjustment shutters for the top and bottom burners regulate the flow of air to the flames.

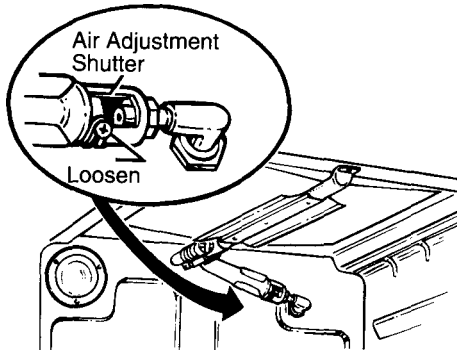

The air adjustment shutter for the top (broil) burner is in the center of the rear wall of the oven.

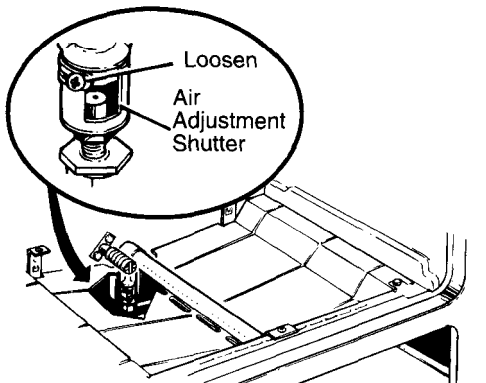

The shutter for the bottom (oven) burner is near the back wall behind the storage drawer or the kick panel (depending on the model). Remove the drawer or panel. (See Care and Cleaning section in this book.)

To adjust the flow of air to either burner, loosen the Phillips head screw and rotate the shutter toward open or closed position as needed.

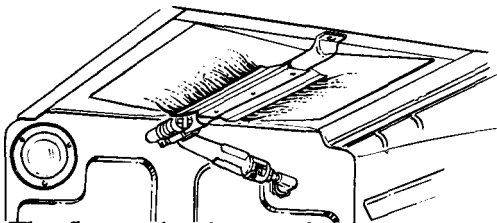

The flames for the top (broil) burner should be steady with approximately 1" blue cones and should not extend out over the edges of the burner baffle.

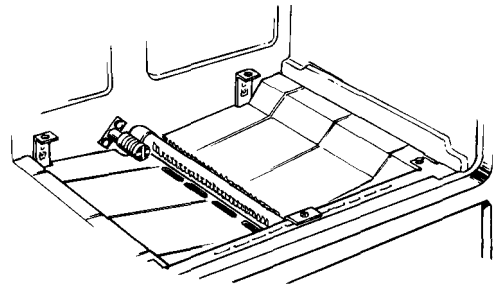

To determine if the bottom burner flames are burning properly, remove the oven bottom and the burner baffle (see below). Flames should have approximately 1" blue cones and, if range is supplied with natural gas, should burn with a yellow tipping. (With most LP gas, small yellow tips at the end of outer cones are normal.) Flames should not lift off burner ports. If lifting is observed, gradually reduce air shutter opening until flames are stabilized. With the baffle in place, the flames should burn steady and should not extend past the edges of the burner baffle.

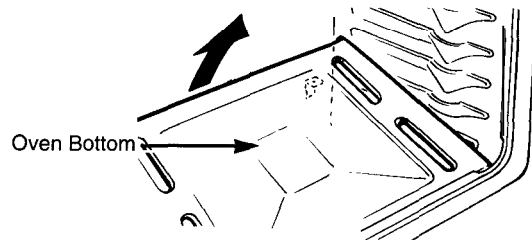

To remove the oven bottom:

1. Remove the knurled screws holding down rear of the oven bottom.
2. Grasp the oven bottom at finger slots on each side.
3. Lift the rear of the oven bottom enough to clear the lip of the range frame, then pull out.

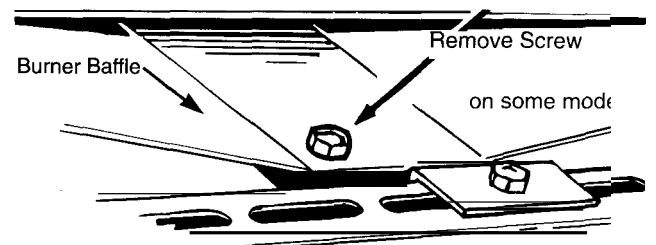

To remove the burner baffle (on some models)

1. Use a nut driver to remove the 1/4" hex-head screw shown in the illustration above. Do not remove any other screws.
2. Pull baffle straight out until it is free from the slot that holds it at rear of oven.



INSTALLATION INSTRUCTIONS

(continued)

ADJUSTING THE AIR ADJUSTMENT SHUTTER ON A MODEL WITH A BROILER DRAWER, IF NECESSARY (See Step 8 if your range is equipped with a storage drawer.)

To determine if the bottom burner flames are burning properly, first remove the oven bottom and the burner baffle (on some models).

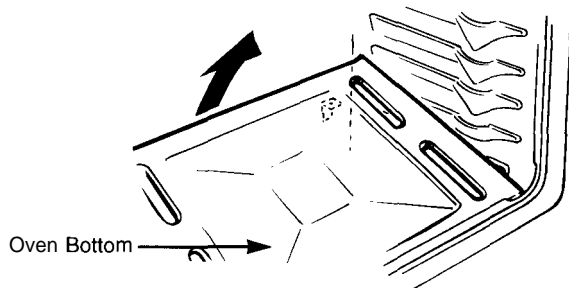

To remove **the** oven bottom:

1. Remove knurled screws holding down rear of oven bottom.
2. Grasp oven bottom at finger slots on each side.
3. Lift rear of oven bottom enough to clear the lip of range frame, then pull out.

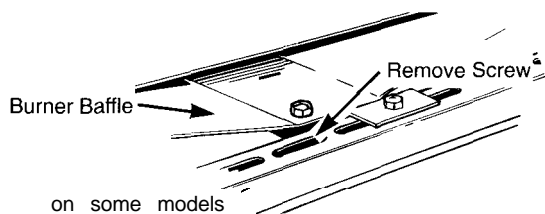

To remove the burner baffle (on some models):

1. Use a nut driver to remove the 1/4" hex-head screw shown in **the** illustration above. Do not remove any other screws.
2. Pull baffle straight out until it is free from the slot that holds it at rear of oven.

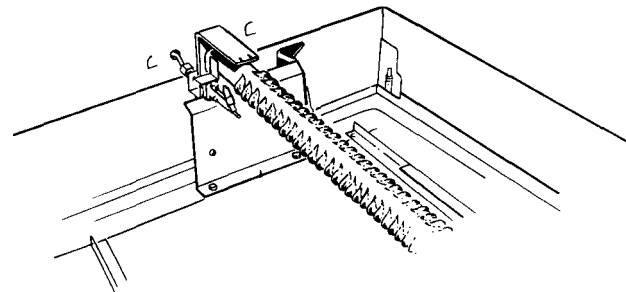

With the baffle removed, properly adjusted flames should have approximately 1" blue cones and, if range is supplied with natural gas, should burn with no yellow tipping. (With most LP gas, small yellow tips at the end of outer cones are normal.) Flames should not lift off burner ports. If lifting is observed, gradually reduce air shutter opening until flames are stabilized. With the baffle in place, or with the oven bottom in place (on models not equipped with a burner baffle), the flames should burn steady. They should not extend past the edges of the burner baffle (or the oven bottom if there is no baffle).

The shutter for the oven burner is near the back wall of the oven and behind the broiler drawer. To remove the broiler drawer:

1. Pull the drawer out until it stops, then push it back in about one inch.
2. Grasp handle, lift and pull broiler drawer out. Remove the metal shield at the rear of the cavity.

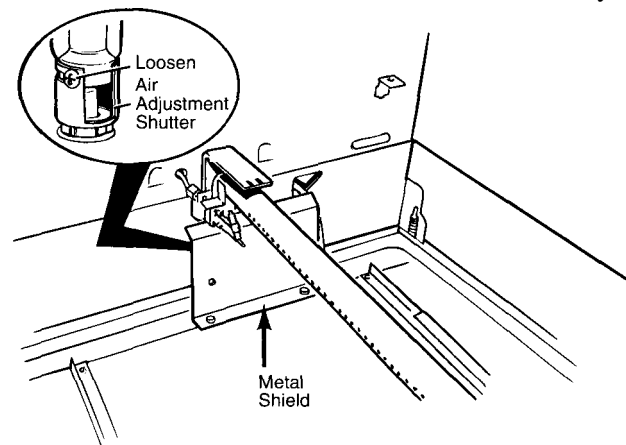

The air adjustment shutter is behind this shield. To adjust the flow of air to the burner, loosen the Phillips-head screw and rotate the shutter to allow more or less air into the burner tube.



LEVELING THE RANGE

1. Remove the storage drawer, broiler drawer or kick panel.
2. Use a 3/16" open-end or socket wrench to back out both rear leveling legs approximately two turns.
3. Use a 1 3/8" open-end or adjustable wrench to back out the front leveling legs two turns.
4. Install the oven shelves in the oven and position the range where it will be installed.
5. Check for levelness by placing a spirit level or a cup, partially filled with water, on one of the oven racks. If using a spirit level, take two readings—with the level placed diagonally first in one direction and then the other.
6. Adjust the leveling legs until the range is level.
7. After the range is level, slide the range away from the wall so that the Anti-Tip device can be installed.

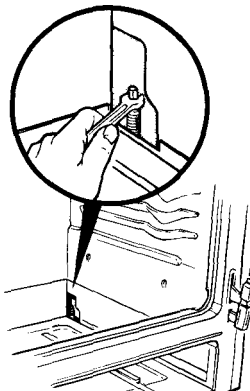

INSTALLING THE ANTI-TIP DEVICE

WARNING:

- Range must be secured with an approved Anti-Tip device.
- Unless properly installed, the range could be tipped by you or a child standing, sitting or leaning on an open door.
- . After installing the Anti-Tip device, verify that it is in place by carefully attempting to tilt the range forward.
- This range has been designed to meet all recognized industry tip standards for all normal conditions.
- . The use of this device does not preclude tipping of the range when not properly installed.
- . If the Anti-Tip device supplied with the range does not fit this application, use the universal Anti-Tip device WB02X7909.

1. Mark the wall where the RIGHT EDGE of the range is to be located. Be sure to allow for the countertop overhang if you intend to install the range next to cabinets.

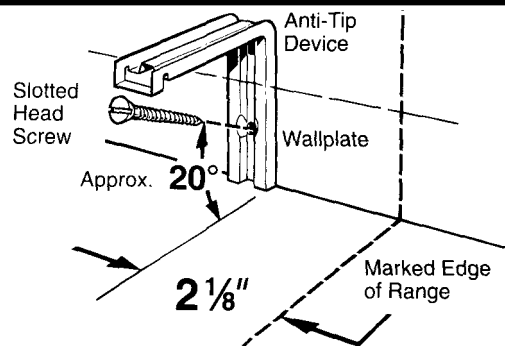

2. Locate the outside edge of the device 2 1/8" toward the center of the range from the marked edge of the range.
 3. Using the device as a template, mark the position of the hole for the screw.
 4. For wood construction, drill a pilot hole at an angle of 20 degrees from the horizontal. A nail or awl maybe used if a drill is not available.
- Mount the Anti-Tip device with the screw provided.

For cement or concrete construction, you will need a 1/4" x 1 3/8" lag bolt and a 1/2" O.D. sleeve anchor, which are not provided. Drill the recommended size hole for the hardware.

Install the sleeve anchor into the drilled hole and then install the lag bolt through the device. The bolts must be properly tightened as recommended for the hardware.

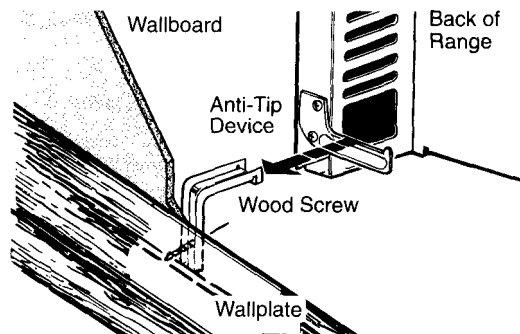

5. Slide the range against the wall, and check for proper installation by grasping the front edges of the rear surface unit openings and carefully attempting to tilt the range forward.

WHEN ALL HOOKUPS ARE COMPLETED:

MAKE SURE ALL CONTROLS ARE LEFT IN THE OFF POSITION.

MAKE SURE THE FLOW OF COMBUSTION AND VENTILATION AIR TO THE RANGE IS UNOBSTRUCTED.



INSTALLATION INSTRUCTIONS

(continued)

HOW TO CONVERT THE RANGE FOR USE WITH LP GAS OR NATURAL GAS

TOOLS REQUIRED:

- T-10 Torxdriver (for sealed burners)
- 1/2" and 3/4" open-end wrench
- Flat blade screwdriver (small)
- Nut drivers or wrenches: 7mm or 5/16" (depending on the size of the spuds)

PREPARE RANGE FOR CONVERSION

- Turn off gas **supply** at **the** wall.
 - Turn off the **electrical** power to **the** range.
- If range has not yet been connected to gas supply, or if flexible connection was made, range maybe pulled out from the wall to make conversion easier.

CONVERT THE PRESSURE REGULATOR

WARNING: Do not remove the pressure regulator from the range.

- For models equipped with sealed burners, remove the storage drawer, broiler drawer or kick panel and locate the pressure regulator at rear of the range.

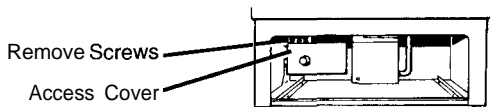

On some models, you may have to remove an access cover also.

For models equipped with dual burners, remove the cooktop and locate the pressure regulator at right rear of range.

- Follow the directions in **A** or **B** that match your regulator type.

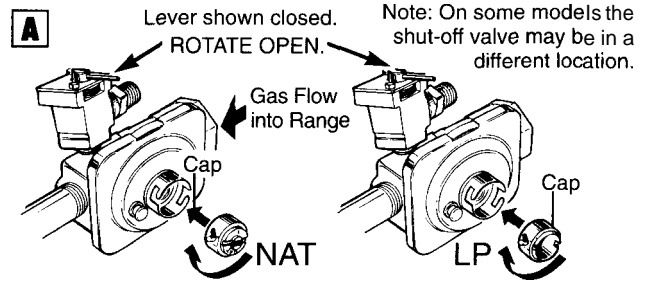

If it is this regulator:

- Use a coin to remove the cap from the pressure regulator.
- Turn the cap over and hook it into the slots. The type of gas to be used should now be visible on the top of the cap.

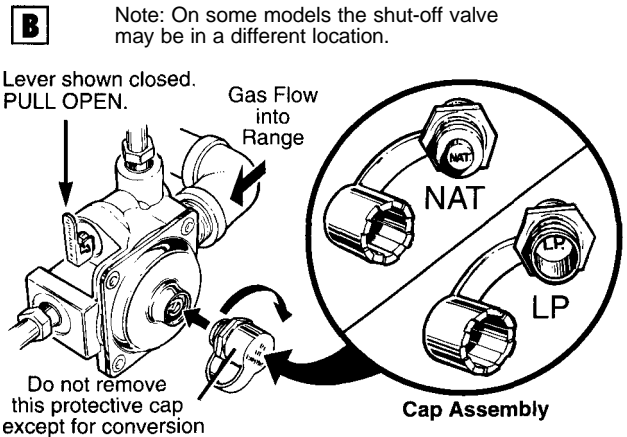

If it is this regulator:

- Unscrew the plastic-protected hex-nut cap from the regulator.
- Carefully pry the protective plastic cap off the threaded metal cap. Gently pull the plastic washer off the threads on the other side of the metal cap.
- Push the plastic cap onto the end of the metal cap displaying the type of gas you are converting to. Press the attached plastic washer onto the threads on the other side of the metal cap.
- Screw the hex-nut cap back into the regulator. Do not overtighten.



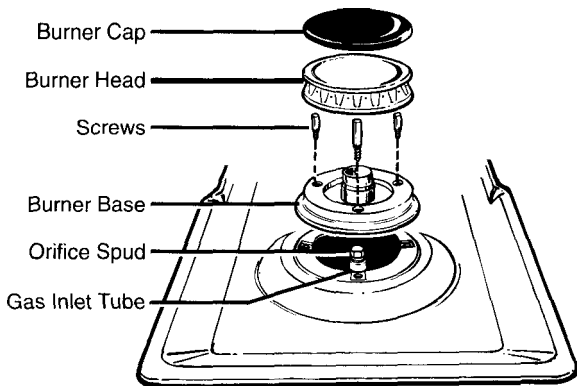

CONVERTING SURFACE BURNERS ON MODELS EQUIPPED WITH SEALED BURNERS (See Step 4 if range is equipped with dual burners.)



1. Remove grates, burner caps and burner heads.
2. Remove burner bases by unscrewing the 3 small screws in each base. **Lift burner straight out.**

DO NOT disconnect the wires from the burner bases unless the cooktop needs to be raised.

3. Remove the brass orifice spud under each burner base by unscrewing spud from fitting with a 7mm or 5/16" wrench (depending on the size of your spuds). Apply a 3/4" wrench to the hex on **the** gas inlet tube as a back-up when removing spud to prevent **the** aluminum tube **from** twisting.

4. Install orifice spuds according to one of the following diagrams (see  or ), for LP gas or natural gas, depending on which you are converting to.

orifice Spuds for Converting to LP Gas:

LP orifice spuds are in a small plastic bag packed with this Use and Care book. LP orifice spuds have a 2-digit number and the Letter "L" on one side. Each orifice spud will also have 1 or 2 grooves on one side, denoting the location on the range where it is to be installed.

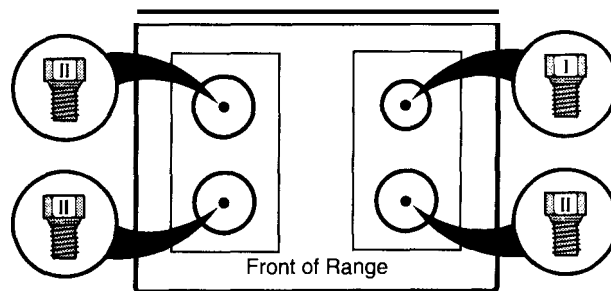

Orifice Spuds for Converting * Natural Gas:

Natural gas orifice spuds have a 3-digit number on one side. Each orifice spud will also have 1, 2 or 3 grooves on one side, denoting the location on the range where it is to be installed.

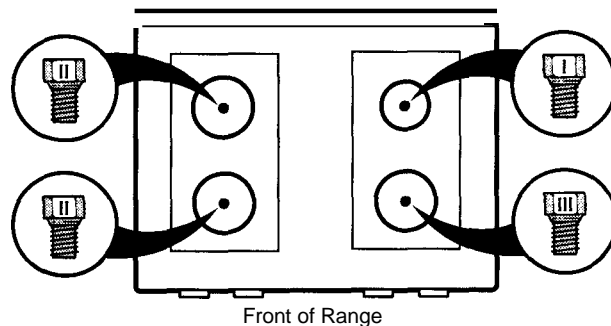

(continued next page)



INSTALLATION INSTRUCTIONS

(continued)

HOW TO CONVERT THE RANGE FOR USE WITH LP GAS OR NATURAL GAS (continued)

5. To prevent leakage, make sure the orifice spuds are securely screwed into the gas inlet tubes. Use a small wrench to hold the inlet tube hex to prevent it from twisting.

6. Put old orifice spuds back in the bag to save for possible future conversion.

Note: If an orifice spud is accidentally dropped, the cooktop can be raised by disengaging the 2 front clips with a large flat blade screwdriver.

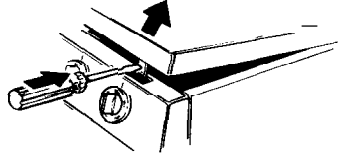

DO NOT attempt to raise the cooktop without removing all 4 burner bases.

If wires were disconnected to remove the cooktop, feed wires through the burner holes in the cooktop. Attach to each burner electrode terminal carefully, making sure not to bend the terminal. Then lower cooktop until it snaps over the clips.

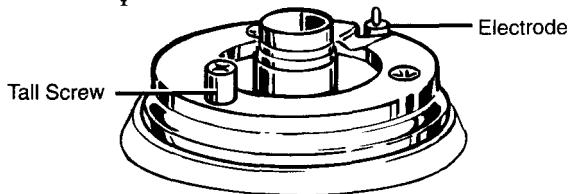

7. Carefully insert burner bases straight down with the tube over the orifice spud. Replace the screws, **making sure the tall screw is opposite the burner electrode in each burner base.**

CONVERTING SURFACE BURNERS ON MODELS EQUIPPED WITH DUAL BURNERS (See Step 3 if range is equipped with sealed burners.)

1. Lift cooktop.
2. Lift burner assemblies straight up and set aside to gain access to surface burner spuds.
3. With a 7mm or 5/16" wrench (depending on the size of your spuds), remove each of the four spuds on the surface burner gas inlet tubes and replace them with the correct gas spuds mounted in a holder at the right rear of the range, above the regulator. Natural gas spuds are brass and LP gas spuds are red or silver. (Mount the spuds that you removed from the inlet tubes back in the holder.) To prevent leakage, make sure spuds are securely screwed into gas inlet tubes.
4. Replace the burner assemblies.
5. Keep all spuds with your range so you have them if you move or get a different gas hook-up.

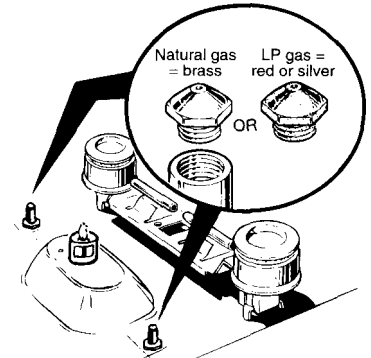

ADJUST OVEN THERMOSTAT (for Models Equipped with Standing Pilots)

1. Remove the oven control knob.
2. Locate the thermostat adjustment screw at left of thermostat shaft. Turn screw clockwise until the small pointer is at LP or N, depending on the type of gas you are converting to.
3. Replace oven control knob.

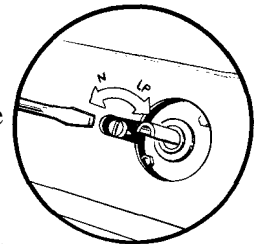



□ CONVERT THE OVEN BURNER ORIFICES

Oven Burner

1. Remove oven door, storage drawer or broiler drawer, oven bottom and burner baffle. The lower burner orifice spud is located behind the storage drawer, broiler drawer or kick panel. (On some models, a metal shield must be removed to access the orifice.)

2. To **convert to LP gas**, use a 1/2" wrench to turn the lower burner orifice spud clockwise. Tighten the spud only until it is snug. To prevent damage, do not overtighten the spud.

To **convert to natural gas**, loosen the spud about 2 turns.

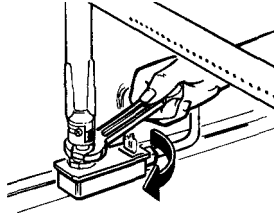

Broil Burner (on some models)

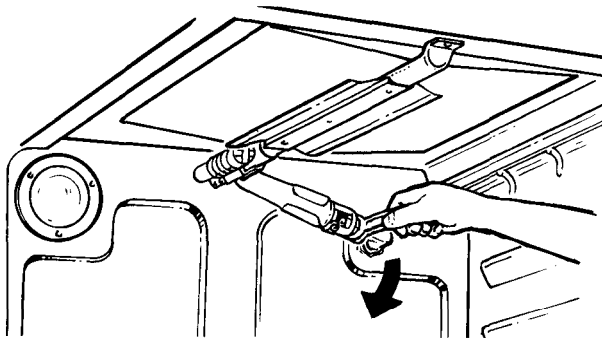

To **convert to LP gas**, use a 1/2" wrench to turn the upper burner orifice spud clockwise. Tighten spud only until it is snug with the base. To prevent damage, do not overtighten spud. To convert to **natural gas**, loosen the spud about 2 turns,

□ CONVERT AIR ADJUSTMENT SHUTTER(S)

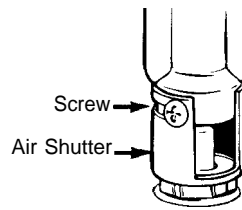

For **LP gas**, loosen the Phillips head screw and rotate the shutter to the full open position. With baffle in place, flames should have approximately 1-inch blue cones and should not extend beyond

the edges of the burner baffle. After 30 seconds of burner operation, check for flames lifting off burner ports. If lifting is observed, gradually reduce air shutter opening until flames are stabilized.

For **natural gas**, the shutter should be open 1/2" or about 3/4 of the way open.

□ CHECK FOR LEAKS

When all connections have been made, make sure all range controls are in the off position and turn on the main gas supply valve. Use a liquid leak detector at all joints and connections to check for leaks in the system.

CAUTION: DO NOT USE A FLAME TO CHECK FOR GAS LEAKS.

When using test pressures greater than 1/2 psig to pressure test the gas supply system of the residence, disconnect the range and individual shut-off valve from the gas supply piping. When using test pressures of 1/2 psig or less to test the gas supply system, simply isolate the range from the gas supply system by closing the individual shut-off valve.



INSTALLATION INSTRUCTIONS

(continued)

HOW TO CONVERT THE RANGE FOR USE WITH LP GAS OR NATURAL GAS (continued)

□ CONVERT TOP BURNER VALVES

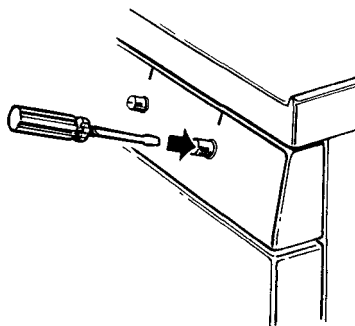
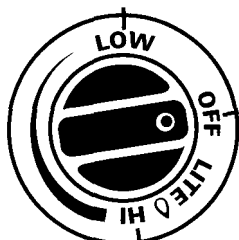

NOTE: Only valves with these types of knobs are adjustable.

1. Turn all top burners to LOW.
2. Remove all four knobs.
3. With a small flat blade screwdriver, turn the valve set screws clockwise to decrease flame size, counterclockwise to increase flame size. Adjust until the flame is about the same height as the top of the burner.
4. Replace knobs.
5. Check for flame outage by opening and closing the oven door several times. If the flame goes out, increase the flame size.

□ ADJUST THE SURFACE BURNER PILOTS (for models equipped with standing pilots)

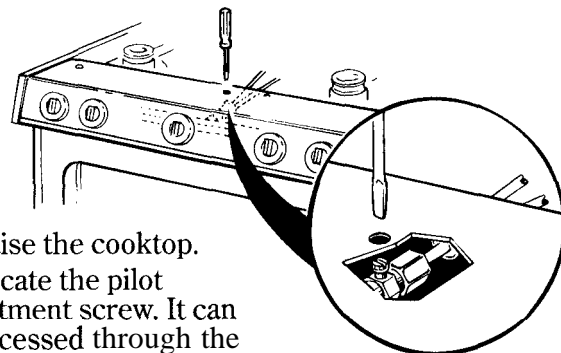

1. Raise the cooktop.
2. Locate the pilot adjustment screw. It can be accessed through the small hole near the center of the manifold panel.
3. To adjust, use a blade-type screwdriver with a shaft diameter of less than 3/16". Turn pilot adjustment screw until pilot is 5/16" high. Do not reduce the flame to less than 5/16" or pilot outage may occur. A pilot flame burning higher than recommended may generate soot (carbon black) on the bottom of your cooktop.

□ CHECK QUALITY OF FLAMES

The combustion quality of burner flames needs to be determined visually.

If burner flames look like (A), call for service. Normal burner flames should look like (B) or (C), depending on the type of gas you use.

With LP gas, some yellow tipping on outer cones is normal.



(A) Yellow flames—
Call for service





(B) Yellow tips on
outer cones—
Normal for LP gas



(C) Soft blue flames—
Normal for natural gas

QUESTIONS? USE THIS PROBLEM SOLVER

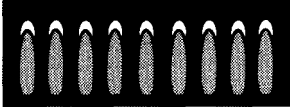

PROBLEM	POSSIBLE CAUSE
OVEN WILL NOT WORK	<ul style="list-style-type: none"> • Plug on range is not completely inserted in the electrical outlet. • The circuit breaker in your house has been tripped, or a fuse has been blown. • Oven controls not properly set,
TOP BURNERS DO NOT LIGHT OR DO NOT BURN EVENLY	<ul style="list-style-type: none"> • Make sure electrical plug is plugged into alive power outlet, • Burner holes on the side or around the top of burner may be clogged. Remove burners (on models with dual burners) or burner heads (on models with sealed burners) or burner caps on spill-proof models, and clean them with a toothpick. Make sure you do not enlarge the holes. On spill-proof models, check electrode area for burned-on food or grease.
BURNERS HAVE YELLOW OR YELLOW-TIPPED FLAMES	<div style="display: flex; justify-content: space-around; align-items: center;"> <div style="text-align: center;">  <p>(A) Yellow flames— Call for service</p> </div> <div style="text-align: center;">  <p>(B) Yellow tips on outer cones— Normal for LP gas</p> </div> <div style="text-align: center;">  <p>(C) Soft blue flames— Normal for natural gas</p> </div> </div> <ul style="list-style-type: none"> • If burner flames look like (A), call for service. Normal burner flames should look like (B) or (C), depending on the type of gas you use. • With LP gas, some yellow tipping on outer cones is normal.
BURNER FLAMES VERY LARGE OR YELLOW	<ul style="list-style-type: none"> • If range is connected to LP gas, check all steps in the Installation Instructions.
OVEN DOES NOT COOK PROPERLY	<ul style="list-style-type: none"> • Make sure thermostat capillary bulb (located in upper portion of oven) is in correct position, not touching oven sides and not coated with anything. • Aluminum foil being used improperly in oven. • Incorrect cookware being used. Check each cooking section for cookware tips or recommendations. • BAKE/BROIL switch (on some models) turned to incorrect setting. • Check common problems listed in Baking, Roasting and Broiling sections. • Oven bottom not securely seated in position.
CLOCK DOES NOT WORK	<ul style="list-style-type: none"> • Range electrical plug must be securely seated in a live power outlet. Check for blown fuse or tripped circuit breaker.
OVEN LIGHT DOES NOT COME ON	<ul style="list-style-type: none"> • Bulb may be loose or burned out. • Electrical plug must be plugged into a live power outlet.
STRONG ODOR	<ul style="list-style-type: none"> • Improper air/gas ratio in oven. adjust oven burner air shutter. • An odor from the insulation around the oven liner is normal for the first few times oven is used. This is temporary,

(continued next page)

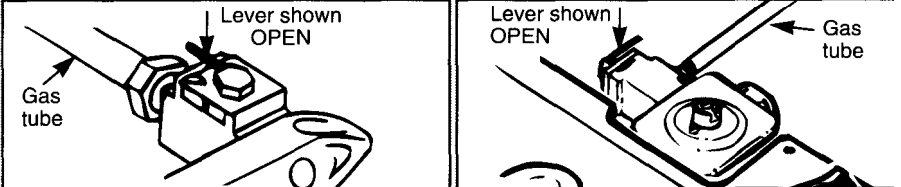

QUESTIONS? USE THIS PROBLEM SOLVER

PROBLEM	POSSIBLE CAUSE
SURFACE BURNERS LIGHT BUT OVEN DOES NOT (DUAL BURNER MODELS ONLY)	<ul style="list-style-type: none">• The oven gas shut off valve may have accidentally been moved during cleaning or moving. To check the oven gas shutoff valve raise the cooktop and look for the gas shut off lever either on the front large tube or at the extreme' right rear corner. Make sure the lever is turned so that it is parallel to the gas tube. 
OVEN TEMPERATURE TOO HOT OR TOO COLD	. The oven thermostat needs adjustment. See the <i>Do It Yourself</i> — Adjust the Oven Thermostat section.

If you need more help... call, toll free:
GE Answer Center®
800.626.2000
consumer information service

We'll Be There

With the purchase of your new GE appliance, receive the assurance that if you ever need information or assistance from GE, we'll be there. All you have to do is call—toll-free!

In-Home Repair Service ***800-GE-CARES (800-432-2737)***

AGE consumer service professional will provide expert repair service, scheduled at a time that's convenient for you. Many GE Consumer Service company-operated locations offer you service today or tomorrow, or at your convenience (7:00 a.m. to 7:00 p.m. weekdays, 9:00 a.m. to 2:00 p.m. Saturdays). Our factory-trained technicians know your appliance inside and out—so most repairs can be handled in just one visit.

GE Answer Center® ***800.626.2000***

Whatever your question about any GE major appliance, GE Answer Center® information service is available to help. Your call—and your question—will be answered promptly and courteously. And you can call any time. GE Answer Center® service is open 24 hours a day, 7 days a week.

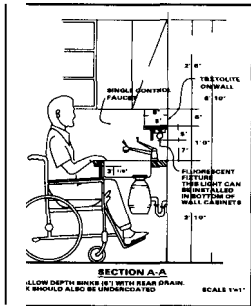

For Customers With Special Needs... ***800.626.2000***

Upon request, GE will provide Braille controls for a variety of GE appliances, and a brochure to assist in planning a barrier-free kitchen for persons with limited mobility. To obtain these items, free of charge, call 800.626.2000.

Consumers with impaired hearing or speech who have access to a TDD or a conventional teletypewriter may call 800-TDD-GEAC (800-833-4322) to request information or service.

Service Contracts ***800-626-2224***

You can have the secure feeling that GE Consumer Service will still be there after your warranty expires. Purchase a GE contract while your warranty is still in effect and you'll receive a substantial discount. With a multiple-year contract, you're assured of future service at today's prices.

Parts and Accessories ***800-626-2002***

Individuals qualified to service their own appliances can have needed parts or accessories sent directly to their home. The GE parts system provides access to over 47,000 parts... and all GE Genuine Renewal Parts are fully warranted. VISA, MasterCard and Discover cards are accepted.

User maintenance instructions contained in this booklet cover procedures intended to be performed by any user. Other servicing generally should be referred to qualified service personnel. Caution must be exercised, since improper servicing may cause unsafe operation.

YOUR GE GAS RANGE WARRANTY

**Staple sales slip or cancelled check here.
Proof of original purchase date
is needed to obtain service
under warranty.**

WHAT IS COVERED

FULL ONE-YEAR WARRANTY

For one year from date of original purchase, we will provide, free of charge, parts and service labor in your home to repair or replace **any part of the range** that fails because of a manufacturing defect.

This warranty is extended to the original purchaser and any succeeding owner for products purchased for ordinary home use in the 48 mainland states, Hawaii and Washington, D.C. In Alaska the warranty is the same except that it is LIMITED because you must pay to ship the product to the service shop or for the service technician's travel costs to your home.

All warranty service will be provided by our Factory Service Centers or by our authorized Customer Care[®] servicers during normal working hours.

Should your appliance need service, during the warranty period or beyond, call 800-GE-CARES (800-432-2737). In Canada, consult your telephone directory for the Cameo Service Center.

WHAT IS NOT COVERED

- Service trips to your home to teach you how to use the product. Read your Use and Care material. If you then have any questions about operating the product, please contact your dealer or our Consumer Affairs office at the address below, or call, toll free: GE Answer Center[®] 800.626.2000 consumer information service
- Improper installation. If you have an installation problem, contact your dealer or installer. You are responsible for providing

adequate electrical, gas, exhausting and other connecting facilities as described in the Installation Instructions provided with the product.

- Replacement of house fuses or resetting of circuit breakers.
- Failure of the product if it is used for other than its intended purpose or used commercially.
- Damage to product caused by accident, fire, floods or acts of God.

WARRANTOR IS NOT RESPONSIBLE FOR CONSEQUENTIAL DAMAGES.

Some states do not allow the exclusion or limitation of incidental or consequential damages, so the above limitation or exclusion may not apply to you. This warranty gives you specific legal rights, and you may also have other rights which vary from state to state. To know what your legal rights are in your state, consult your local or state consumer affairs office or your state's Attorney General.

Warrantor: General Electric Company

**If further help is needed concerning this warranty, write:
Manager—Consumer Affairs, GE Appliances, Louisville, KY 40225**

This book is printed on recycled paper.

Part No. 164D2764P032

Pub No. 49-8440

4-93 CG

JGBS02EN JGBS06ES JGBS19GEP
JGBS02PN JGBS12GER JGSS05GER
JGBS04ER JGBS14GES JGSS05GES
JGBS04PR JGBS15GER JGBC15GE
JGBS04GER JGBS16GEP JGBC16GEP
JGBS04GPR JGBS17GER JGBC17GER
JGBS06ER JGBS18GES

Printed in Louisville, KY