

GE Energy  
Oil & Gas

# Gas Turbines

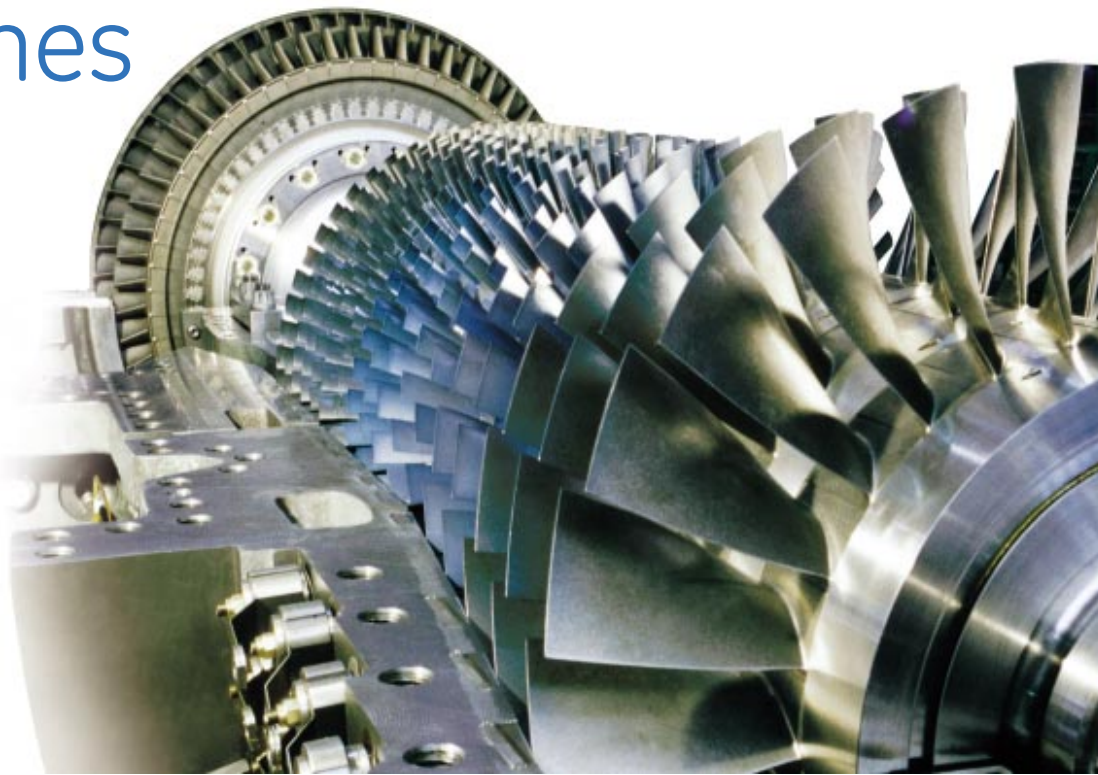

# Contents



3	Introduction
4	GE5
8	GE10
10	MS5001
11	MS5002C-D
12	MS5002E
13	MS6001B/MS7001EA/MS9001E
14	PGT16
15	PGT25
16	PGT25+
17	LM6000
18	Main Components
18	Axial Compressor
19	First Stage Nozzles
19	Buckets and Wheels
20	Gas Turbine Operability
22	LNG Exploration and Production, Floating Production Units
23	Pipeline
24	Refinery and Petrochemicals
25	Test Facilities
26	Service
27	Training
28	Gas Turbine Data Sheet

GE Energy manufactures a complete line of gas turbines for all major Oil & Gas Industry applications. They are installed in natural gas plants, gas compression stations, oil booster stations, petrochemical plants and power generation and cogeneration plants worldwide. GE Energy Oil & Gas Business has long-standing experience in manufacturing gas turbines dating back to 1961 when a manufacturing agreement was established with General Electric (U.S.A.) to complement the existing portfolio of products for the petroleum and petrochemical industries (reciprocating and centrifugal compressors, gas engines, pumps, valves, etc.). A proven combination of sound design and quality assurance techniques places these gas turbines among the world's most reliable. Basic models produced by GE Energy cover the 5,000 to 124,000 kW power range. They can be provided in simple or regenerative cycles for mechanical drive or generator drive applications. Extensive research and development, advanced design procedures, modern manufacturing technology and on-site experience are behind the success achieved by GE Energy gas turbines.

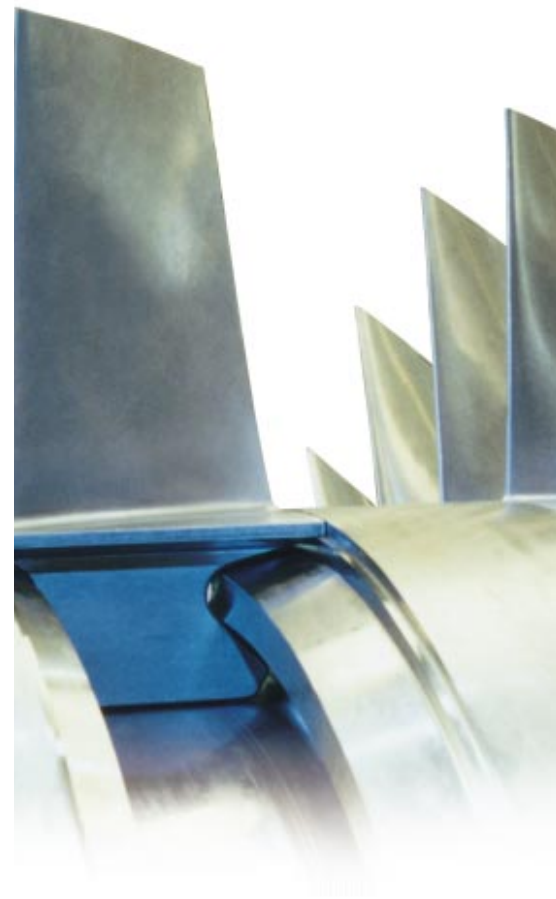

# GE5 Gas Turbines

The new GE5 is a compact, state-of-the-art, 6 MW class industrial gas turbine. The unit was developed in two configurations: a cold-end drive single shaft for power generation and a hot-end drive twin shaft for mechanical drive applications. Maximum commonality has been maintained between the single and twin shaft models. Both units share a common gas generator, with operating and maintenance benefits in installations where mixed operation is required. The twin shaft engine is obtained by simply removing the second stage turbine from the single shaft unit and adding a two-stage power turbine.

The unit is an evolution of the existing PGT5 which builds on the experience of the successful GE10 model. The merging of proven GE Aircraft Engines and GE Energy - Oil & Gas technology coupled with the benefits of GE's Six Sigma Total Quality Methodology have resulted in a rugged machine with high efficiency and reliability, and low operating and maintenance cost.

The high efficiency of the machine coupled with low emissions make the GE5 a leader in its class for most applications.

While the single shaft version is particularly suitable for power generation and cogeneration due to the high exhaust temperature, the twin shaft version, with wide operating speed range, is designed to be a reliable and efficient mechanical drive for compressors and pumps.



## COMPRESSOR

The GE5 compressor benefits from several decades of compressor design evolution focused on achieving higher efficiency. The new compressor is scaled from the similar GE10 unit. It is a high performance, axial flow design derived from GE Aircraft Engine technology. GE Energy, utilizing GE Aircraft Engine expertise, has greatly improved overall compressor performance without sacrificing reliability or mechanical integrity.

The 11-stage compressor produces a pressure ratio of 14.8:1. The first three stages of stator blades are adjustable to optimize efficiency by maximizing exhaust gas temperature at part load operation. Compressor blades are assembled onto a solid forged rotor while stator blades are mounted onto ductile cast iron casings.

## TURBINE

The HP turbine itself is a compact, high efficiency design with two stages in the single shaft version and three stages in the twin shaft model (2 in the LPT Turbine). The advanced design methodology utilized by GE Energy resulted in a high performance machine with significantly fewer parts. In addition, state-of-the-art cooling techniques permitted the use of well proven materials.

The GE5 uses an enhanced nozzle and bucket design similar to those used in aircraft engines. Cooling air is provided to the first stage nozzles and buckets to enable higher firing temperatures and enhanced efficiency.

The LP turbine of the twin shaft version has two stages

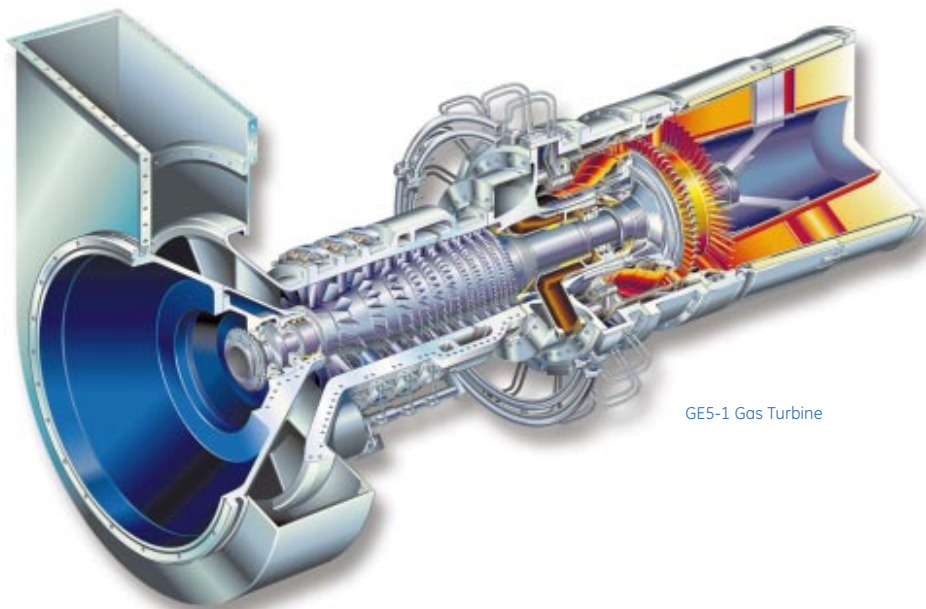

GE5-1 Gas Turbine

and has been designed exploiting the experience the company has gained over the past 20 years with the PGT25, PGT10, PGT16 and more recently with the PGT25+ (High Speed Power Turbine). The design speed of the GE5-2 low pressure turbine is 12,500 rpm, with a capability range from 50% to 105%, which is ideal for direct coupling of GE Energy centrifugal compressors in the 6 MW power range.

#### COMBUSTOR

The GE5 uses an annular combustor architecture, to achieve the maximum efficiency while maintaining the highest reliability standards. The unit is configured with a DLE combustion system that reduces the NO<sub>x</sub> and CO emission levels. It consists of a compact annular combustor in Hastelloy X with 18 fuel nozzles. Each fuel nozzle includes a double counter-rotating swirler to optimize fuel mixing and flame stability for extra clean combustion.

This combustion system is designed for operation on natural gas. One fixed, high-energy spark ignitor is used to achieve simple and reliable ignition.



# GE5 Gas Turbines

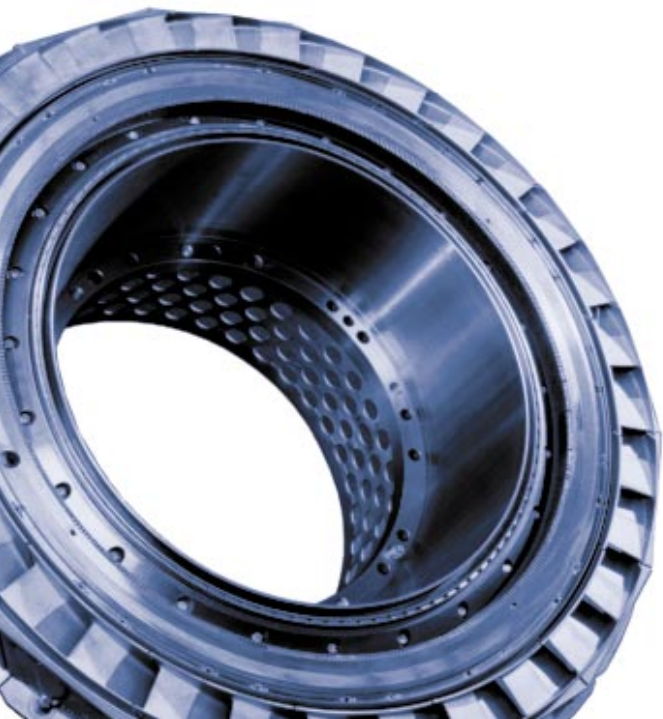

## PACKAGE

The gas turbine packages were designed with an emphasis on standardization, and optimization of factory and field assembly operations. The result is a standard package capable of satisfying the needs of a typical user for low installation and maintenance costs. The package is also designed and manufactured as a modular system. Both the single and twin shaft gas turbines are normally supplied as completely enclosed, on-base soundproof packages of very compact dimensions with standard noise attenuation levels of 85 dB(A) at 1 m. The Starting System, Lube Oil System and Fuel System are fully integrated on the base plate. In the single shaft configuration, the base plate also supports the load gear; the off-base equipment is limited to the lube oil cooler and the generator. The entire GE5-1 package is compact, with a footprint of only 5810 mm (L) x 2500 mm (W) providing the user with the flexibility to locate the system indoors or near pre-existing facilities. The inlet filtration module and inlet duct are designed to be perfectly integrated with the enclosure and, in order to optimize the footprint and transportation, are supported by the enclosure itself. For the twin shaft, the design guideline has been the flexibility to satisfy a broad spectrum of customer plant needs. As required by the Oil & Gas Industry, the standard enclosure was designed to be equipped with different filtration systems (conventional/self cleaning), different inlet/exhaust duct arrangements and noise levels and always allowing high accessibility and maintainability. Both the single and twin shaft packages are provided with wide access doors conveniently located around the enclosure for easy access to the engine assembly and auxiliary components.

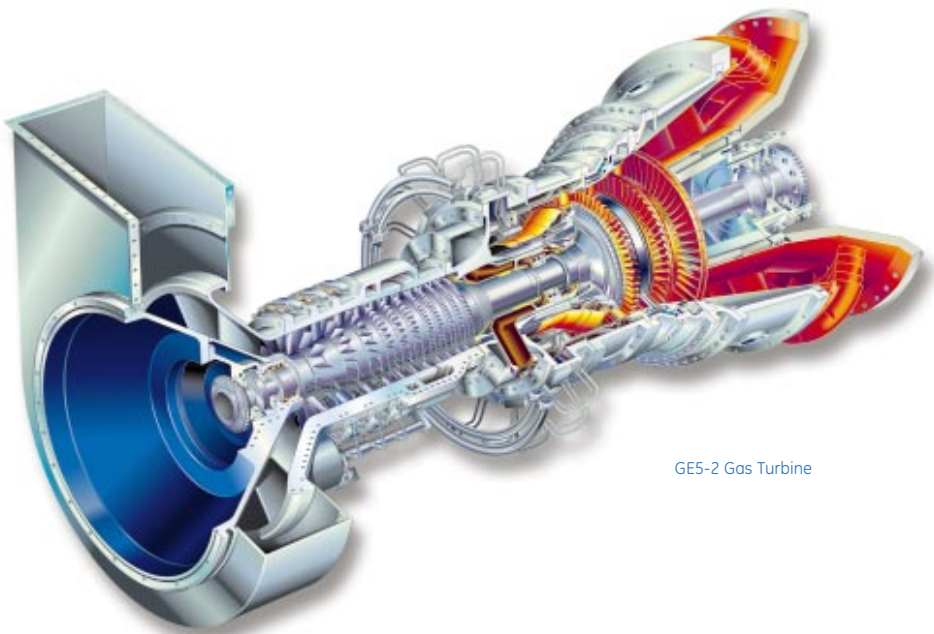

GE5-2 Gas Turbine

#### MAINTENANCE PHILOSOPHY

A fundamental philosophy of the new GE5 gas turbine is simplicity of design, layout and procedures. This affords the GE5 a position of market leadership in cost and availability through innovative programs for service and sparring, and through package assembly and disassembly flexibility. Drawing on GE's undisputed leadership in the design and manufacture of both aero-derivative and heavy-duty machines, the GE5 represents a unique marriage of the best of both types of engines.

This provides customers with the benefit of a variety of cost-effective service programs (e.g., condition-based maintenance, site-based or exchange engine programs) and the ability to tailor the service offering to best suite the customer's specific applications.

#### SOME KEY POINTS:

Annual borescope inspections are the basis of the condition based maintenance program.

The inspection of the hot parts is carried out approximately every two years. Major overhaul of the gas turbine is required at around 50,000 fired hours, and can be completed on site, or in a shop; effects of downtime can be minimized through the use of an exchange engine.

# GE10 Gas Turbines

The GE10 is a 12 MW range heavy-duty gas turbine available in both single shaft and two shaft versions. It is the evolution of the field-proven PGT10A and incorporates the latest in aerodynamic design in a compact and versatile package arrangement. The design of the GE10 has been highly refined based on the extensive experience gained operating in all types of environments. There are over one hundred units running under conditions ranging from the cold of Alaska and Siberia to the heat of the desert and the humidity of the tropics. Its efficiency and operational flexibility make the GE10 a cost-effective choice for all applications. The gas generator consists of an 11 stage, high efficiency, axial-flow compressor and a single combustion chamber capable of burning a great variety of fuels. Maximum commonality has been maintained between the single and twin shaft models. Both units use the same gas generator. The two shaft engine is obtained by simply removing the third stage turbine from the single shaft unit and adding a two-stage low pressure power turbine. This feature is particularly beneficial in reducing operating and maintenance costs in installations where mixed operation is required.

GE10-1 Gas Turbine

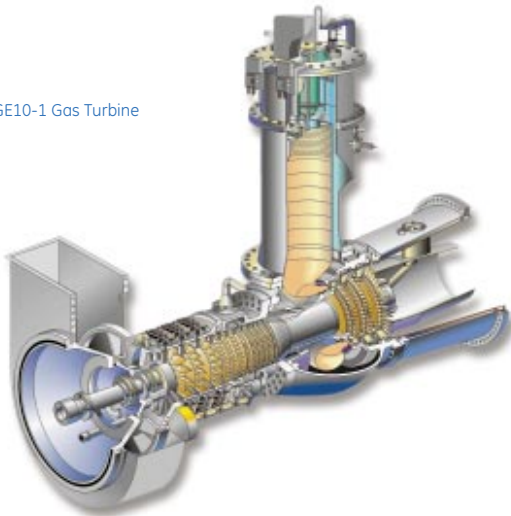

## COMPRESSOR

The compressor is a high performance eleven stage axial flow design with a 15.5:1 pressure ratio operating under transonic flow conditions, derived from GE Aircraft Engine aero-derivative technology. The first three rows of stator blades are variable to optimize cycle efficiency over a wide range of loads. The gas generator is joined to the base plate at the load flange location. This configuration avoids load flange movement during all operating conditions (start-up, warm-up, full speed/full load) and during thermal transients.

## TURBINE

The power turbine is available in two configurations: a single shaft version primarily for power generation; and a two shaft version for mechanical drive applications.

### Generator Drive — Single Shaft Version.

The GE10-1 is a single shaft heavy duty gas turbine designed primarily for generator drive applications. The turbine section is composed of three reaction stages. The first two stages use the proven design of the previous PGT10 HP turbine model with cooling provided by air bled from the axial compressor. The second and third stages have interlocked shrouds to limit tip leakage and blade vibration. At partial load, inlet variable guide vanes permit optimization of performance with no appreciable change from simple cycle full load efficiency. The GE10 is a compact turbogenerator optimized for simple cycle, combined cycle and cogeneration plants (e.g., power shaft on cold side; axial discharge of hot gases) and suitable for utilization even where space is limited.



### Mechanical Drive — Two Shaft Version.

The GE10-2 is the two shaft version of the GE10 intended for mechanical drive applications. The turbine consists of four reaction stages. The first two stages or High Pressure Turbine which are used to drive the axial compressor are common with the GE10-1 model. The low pressure shaft is a double stage, high-energy turbine with variable first stage nozzles which provide maximum flexibility for mechanical drive applications. These third and fourth stages which make up the Low Pressure Turbine are coupled to the power shaft driving the load. They are cooled by air bled from the axial compressor.

### COMBUSTOR

The combustion system consists of a single, slot-cooled combustion chamber assembly that permits quick and easy maintenance of the hot gas path. This combustion chamber is able to burn a wide range of fuels including liquid distillates, residuals and all gaseous fuels including low BTU gas with system modifications.

The GE10 combustion system is available in both conventional and DLE configurations. The DLE (dry low emissions) system is a simple, field-proven design that guarantees operation at 25 ppmv NO<sub>x</sub> (burning Natural Gas). The GE10 can also utilize steam and water injection for NO<sub>x</sub> reduction and power augmentation. Further reduction of emission levels is a constant objective of our continuing combustion development and test programs.

### AUXILIARIES

The integrated lubrication system (including oil tank) that feeds the gas turbine, the speed reduction gear and the electric generator is located on the turbine base plate. The main lube oil pump is mechanically driven by the gearbox. An AC electric motor-driven pump guarantees lubrication during normal operation while a

DC electric motor-driven pump is provided for emergency backup. In the standardized package configuration the oil is cooled by an air cooler. A water cooler can be provided upon customer request. The thrust and journal bearings are of the tilting pad type. The starting system consists of a V.F.D. motor drive for the single shaft version.

The twin shaft can be equipped with a torque converter plus electric motor or starting expansion turbine.

The GE10 control system has been implemented to assure a high degree of integration and standardization between the engine and the turbine generator package. Programmable modules guarantee easy implementation of any control and protection scheme to tailor the control system to the application and customer needs.

### PACKAGE

The package designed for power generation applications is optimized to minimize plant dimensions and to reduce maintenance cost and time. In the standard configuration, the speed reduction gear is mounted on the gas turbine base plate. The auxiliaries are installed on a separate base plate permanently joined to that of the gas turbine base plate to form a single lift on which the sound-insulated enclosure is mounted.

The electric generator is installed on a concrete foundation to limit the shipping dimensions. The overall length of the genset is about 13 m.

The other modules completing the system are the oil/air exchangers, the air intake filter chamber, the suction duct (vertical suction) and the exhaust system (axial exhaust).

The enclosure has a sound pressure level lower than 85 dBA at 1 m. This acoustic design meets ISO NR 50 limits at 100 m.

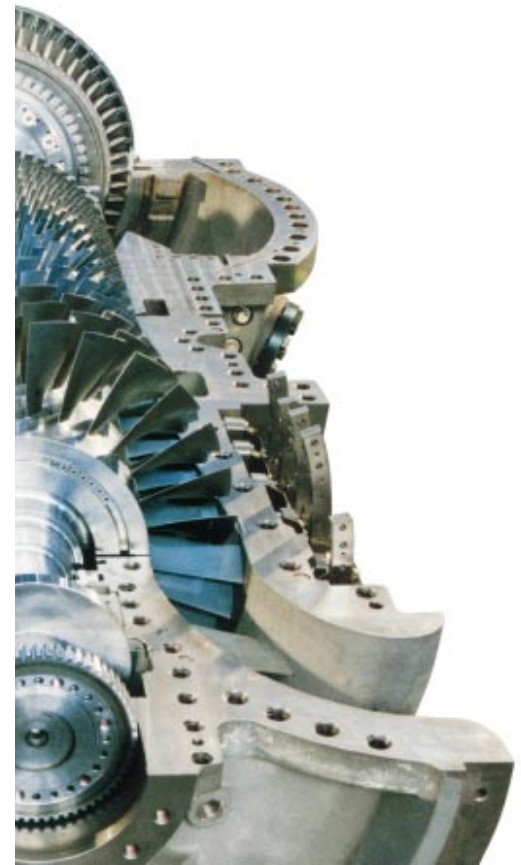

# MS5001 Gas Turbines

The MS5001 single shaft turbine is a compact heavy-duty prime mover designed for long life and ease of operation and maintenance. The three main features of its simple design are:

- 17-stage, axial compressor
- Combustion system with 10 chambers capable of burning a wide range of fuels including natural gas, light and heavy distillates, and crude and residual oil. A DLN System is also available.
- Two-stage turbine with high energy stage design. The first-stage nozzles are cooled by the axial compressor discharge air.

The MS5001 Gas Turbine is the ideal solution for power generation where low maintenance, reliability and economy of fuel utilization are required. Low operating and investment costs make the MS5001 package power plant an economically attractive system for load generation. The MS5001 is also ideally suited for cogeneration achieving a very high fuel utilization index and considerable fuel savings. Typical applications are industrial plants for cogeneration of power and process steam or district heating systems.

As a consequence of the extremely favorable operating, maintenance and economic characteristics of the MS5001 it has been very well accepted in the industry and there are more than 2500 units in operation all over the world.

MS5001 Gas Turbine

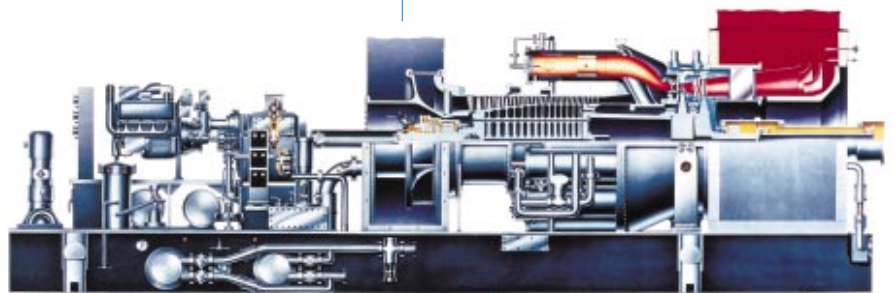

# MS5002C-D Gas Turbines

The MS5002 is a gas turbine specifically designed for mechanical drive applications such as gas boosting, gas injection/re-injection, oil & gas pipelines, LNG plants and gas storage. It has a broad operating speed range to meet the operating requirements of the most common driven equipment (centrifugal compressors and pumps) as well as the ability to burn a large variety of gaseous and liquid fuels. The MS5002 gas turbine was introduced in the market in the 1970s and has been updated and up-rated over the years to meet the industry demand for increased output. Presently two versions are available:

- MS5002C
- MS5002D

The MS5002 two-shaft, heavy-duty gas turbine is designed for high operating efficiency over a wide range of speed and load. The simple design and extreme robustness of the MS5002 allow complete maintenance to be performed on site without the need for specialized tooling or service shop assistance. The main features of its design are:

- High pressure shaft consisting of a 16-stage (17 for MS5002D), axial-flow compressor and a single-stage, high energy turbine. The first stage nozzles are air cooled and the second stage nozzles are of the variable angle type.
- Low pressure shaft is a single stage, high energy turbine.
- Twelve combustion chambers are contained within a single wrapper. A wide range of gaseous and liquid fuels can be burned. A DLN Combustion System is also available.
- A centralized lube oil system supplies clean, cooled, pressurized oil to lubricate the gas turbine and the driven equipment including the oil required for any compressor seals.

As a consequence of the extremely favorable operating, maintenance and economic characteristics of the MS5002 nearly 500 units (more than 300 manufactured by GE Energy) have been installed world-wide in all types of environments (arctic, desert, off-shore etc.) always demonstrating ease of operation and very high reliability and availability.



MS5002 Gas Turbine

# MS5002E Gas Turbines

The MS5002E, the latest addition to the GE Energy family of gas turbines, is a 32MW class machine designed for high efficiency, low environmental impact and high reliability. The MS5002E will be available in both single and dual-shaft versions to cover power generation and mechanical drive applications.

This latest model was developed in response to customer demand for a machine in the 32 MW range with low fuel consumption, reduced emissions and high availability and reliability. In order to guarantee high reliability and availability the MS5002E has a conservative firing temperature with respect to the state-of-the-art. High efficiency was achieved through the use of advanced design tools to optimize airfoils, clearances, leakages and the distribution of cooling flows.

The MS5002E offers NOx emission levels down to 25 ppm through the use of a dry-low emission combustion system derived from the GE Energy DLN2 combustion technology.

The design of the MS5002E was thoroughly validated through an extensive test program that included a full scale test of the axial compressor, full scale rotordynamic testing and full load testing of the gas turbine system.

The MS5002E single and dual shaft 32MW class machine represents a world-class engineering achievement to provide customers with a high efficiency, low emissions machine with outstanding reliability matched for Oil & Gas Industry applications.

## EXPECTED PERFORMANCE

Output Shaft	32 MW
SC Efficiency	36%
Pressure Ratio	17:1
LPT Shaft Speed	5714 rpm
Exhaust Temperature	511 °C
NOx Emission	25 ppm

MS5002E Gas Turbine

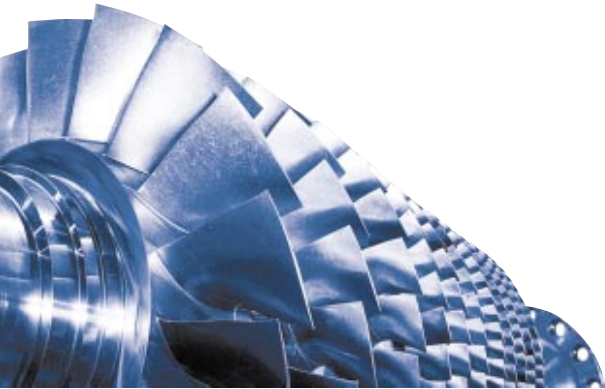
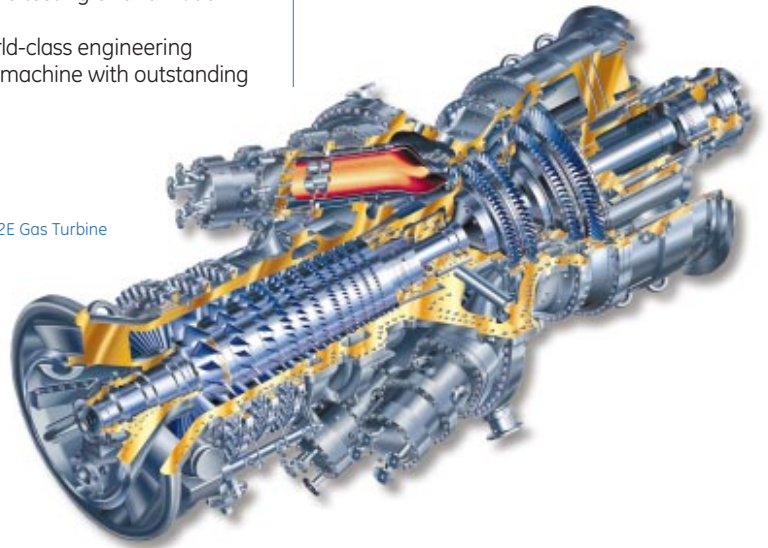

# MS6001B/MS7001EA/MS9001E

Available for Oil & Gas Applications

## APPLICATIONS

The 7EA is fuel-flexible, and can operate on natural gas, liquefied natural gas (LNG), distillate and treated residual oil in a variety of applications including:

- mechanical drive for large compressor trains
- simple cycle and combined cycle
- base load and peaking power generation
- industrial and cogeneration

## MS6001B

The MS6001 is a single-shaft, heavy-duty gas turbine. The high efficiency axial compressor has 17 stages. The combustor has ten combustion chambers with individual fuel nozzles. The machine has a three-stage impulse turbine with air-cooled buckets and stationary nozzles on the first two stages to achieve higher firing temperatures and consequently higher efficiency without compromising hot section component life.

MS6001B  
Gas Turbine



## FEATURES

- 17-stage compressor with stacked disk design
- reverse flow combustion system with an individual nozzle single combustion chamber
- 3-stage turbine with air-cooled, first and second-stage nozzles and buckets
- three-bearing rotor supports

## MS7001EA

The GE MS7001EA is a highly reliable, mid-sized packaged power plant developed specifically for 60 Hz applications. With design emphasis placed on energy efficiency, availability, performance and maintainability, the 7EA is a proven technology machine with more than 775 units of its class installed or on order worldwide as of December 1999. The simple, medium-sized design of the 7EA lends itself to flexibility in plant layout and easy, low cost addition of power augmentation when phased capacity expansion is needed. A predecessor of the 7FA, the 7EA is ideal for plants that require high efficiency along with shaft speed for direct coupling to the generator.

MS7001EA  
Gas Turbine



## MS9001E

The MS9001 is a single-shaft, heavy-duty gas turbine developed for generator drive service in the 50 Hz market. Its efficiency is approx 33% in simple cycle mode and over 50% when operated as a combined cycle. The MS9001 is designed to burn a variety of liquid and gaseous fuels.

MS9001E  
Gas Turbine

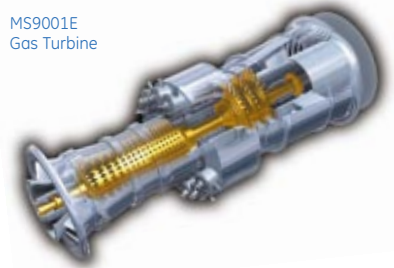



# PGT16 Aeroderivative Gas Turbines

The PGT16 gas turbine consists of the twin spool GE Aeroderivative LM1600 Gas Generator coupled with a rugged, industrial power turbine designed by GE Energy's Oil & Gas businesses. The LM1600 Gas Generator is derived from the F404 turbofan aircraft engine.

The power turbine of the PGT16 gas turbine is identical to that of the PGT10 heavy duty, high efficiency gas turbine which has been in operation for more than half a million hours.

The power turbine shaft speed (7900 RPM) is optimized for direct coupling to pipeline, injection and process centrifugal compressors with a speed range that matches most operating requirements encountered in oil & gas applications. For generator drive applications the PGT16 synchronously coupled to a generator with a speed reduction gear is a highly flexible turbogenerator which can be operated as a simple cycle or in combined or cogeneration cycle applications with an electrical efficiency close to 50%.

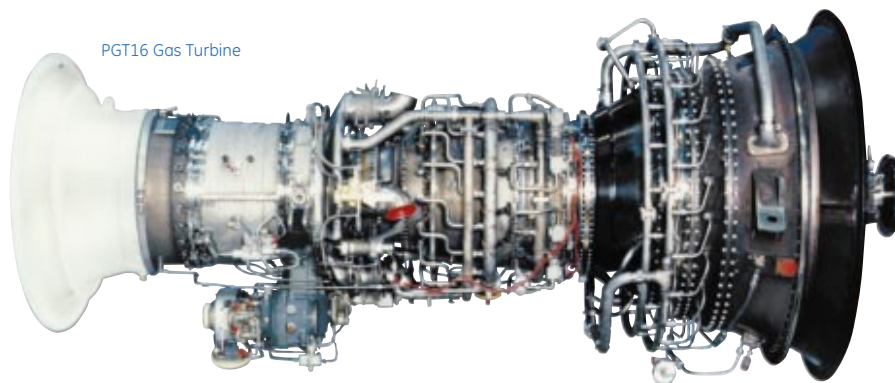

PGT16 Gas Turbine

## GENERAL SPECIFICATIONS

### Compressor

- Twin spool axial compressor (3 stage LP compressor, 7 stage HP compressor)
- Pressure ratio 20.1:1

### Combustion

- Annular combustion chamber (18 fuel nozzles)

### Turbine

- Twin Spool Gas Generator turbine (1 stage HP turbine, 1 stage LP turbine)
- Two stage Power turbine with variable angle first stage nozzles

### Package

- Completely mounted on a single base plate
- The enclosure is integral with the base plate providing maximum accessibility for maintenance of the gas turbine and auxiliaries

### Emission Control

- Steam or water injection systems for NOx abatement
- Dry Low Emission (DLE) combustion system

# PGT25 Aeroderivative Gas Turbines

The PGT25 gas turbine consists of an LM2500 GE aeroderivative gas generator coupled with a rugged, industrial power turbine designed by GE Energy.

## GAS GENERATOR

The LM2500 GG has already accumulated several million fired hours not only as an aircraft engine (TF39 and CF6-6 engines), but also in the industrial field in many mechanical drive applications (marine, onshore and offshore gas transmission) and for generator drive service. The LM2500 gas generator incorporates a 16-stage axial-flow compressor capable of reaching an 18:1 pressure ratio. Inlet guide vanes and adjustable stator vanes on the first six compressor stages provide for efficient operation over the entire operating range.

## POWER TURBINE

The PGT25 power turbine components were designed by GE Energy taking into account many years of experience gained in the field of heavy duty gas turbines and axial/centrifugal compressors. The aerodynamic blading was designed with the main objective of obtaining very high efficiency at both design and reduced speeds.

The 6500 RPM design speed means the turbine can have two stages with a moderate aerodynamic load and a high expansion efficiency. The two expansion stages are of the high energy, three-dimensional design type.

The investment casting superalloy selected for the blading assembly has a cobalt base for the nozzles and a nickel base for the rotor blading (i.e. the same materials used on heavy-duty gas turbines). A large creep and fatigue (LCF-HCF) safety margin on blade life is ensured by a moderate gas temperature at the power turbine inlet. The two-stage rotor is overhung and the shaft is supported by two tilting pad bearings contained in a cylindrical cartridge. The system can be easily dismantled with a simple translation of the gas generator within the package space thus reducing the time required for a major overhaul of the power turbine to a few days. Engineering simplicity and advanced materials yield long time between overhauls and reduced maintenance costs.

The turbine is assembled on a light but rigid base plate with extensive use of prefabricated standard components preassembled and tested in the shop to minimize on-site assembly time.

## GENERAL SPECIFICATIONS

### Compressor

- Sixteen stage axial compressor
- Pressure ratio 17.7:1

### Combustion

- Annular combustion chamber (30 fuel nozzles)

### Turbine

- Two stage Gas Generator turbine
- Two stage Power turbine (6500 RPM).

### Package

- Completely mounted on a single base plate
- The enclosure is integral with the base plate providing maximum accessibility for maintenance of the gas turbine and auxiliaries

### Emission Control

- Steam or water injection systems for NO<sub>x</sub> abatement
- Dry Low Emission (DLE) combustion system

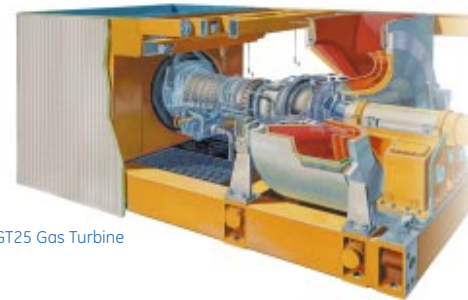

PGT25 Gas Turbine

# PGT25+ Aeroderivative Gas Turbines

The PGT25+ gas turbine was developed for 30 MW ISO shaft power service with the highest thermal efficiency level (approx. 40%). The PGT25+ gas turbine consists of the GE Aeroderivative LM2500+ Gas Generator (updated version of the LM2500 gas generator with the addition of a zero stage to the axial compressor) coupled with a 6100 RPM, 2 stage Power Turbine (High Speed Power Turbine - HSPT). Built on the LM2500 heritage and demonstrated 99.6% reliability, the LM2500+ incorporates technology improvements and a large percentage of parts in common with the LM2500 to deliver the same outstanding level of reliability. Designed for ease of maintenance, the LM2500+ also provides a high level of availability. High efficiency and reliability are among the large number of benefits contributing to PGT25+ customer value. Specialized aeroderivative annular combustion chamber fuel nozzles makes the PGT25+ ideal for a wide range of mechanical drive (gas pipeline etc.), power generation, industrial cogeneration, and offshore platform uses in any environment. Engineering simplicity and advanced materials yields long time between overhauls and reduce maintenance costs.

## GENERAL SPECIFICATIONS

### Compressor

- Seventeen stage axial compressor
- Pressure ratio 21 15:1

### Combustion

- Annular combustion chamber (30 fuel nozzles)

### Turbine

- Two stage Gas Generator turbine
- Two stage Power turbine (6100 RPM).

### Package

- Gas Generator, Power Turbine and auxiliary systems mounted on a single base plate
- The enclosure is integral with the base plate providing maximum accessibility for maintenance of the gas turbine and auxiliaries

### Emission Control

- Steam or water injection systems for NOx abatement
- Dry Low Emission (DLE) combustion system

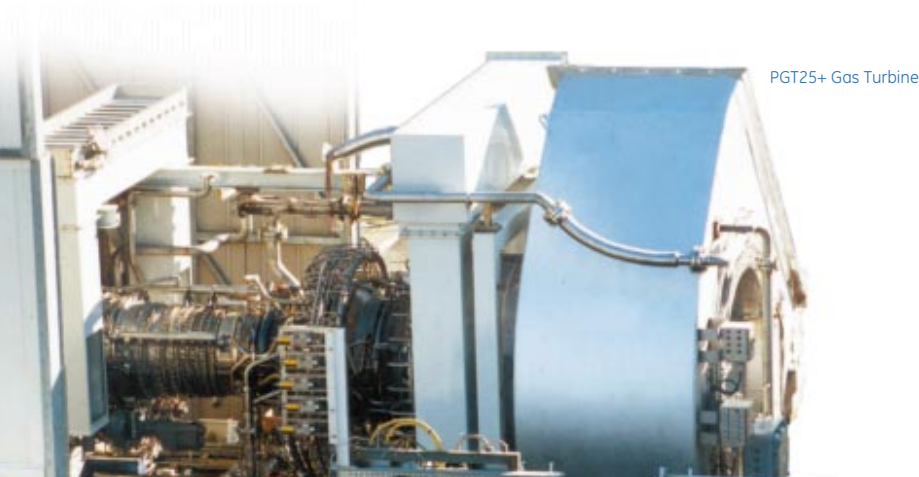

# LM6000 Aeroderivative Gas Turbines

The LM6000 is a simple-cycle, two-shaft, high performance gas turbine derived from the GE CF6-80C2 high bypass turbofan aircraft engine, the industry standard for high-thrust engines. Delivering more than 44.8 MW at over 42.7% thermal efficiency, the powerful LM6000 is the most fuel-efficient, simple-cycle gas turbine in the world. Direct drive provides 60,000 shaft horsepower from either end of the low pressure rotor for a wide range of electric power generation and mechanical drive applications in any environment.

High thermal efficiency, low cost, and installation flexibility make the LM6000 the ideal choice as a prime driver for utility peaking, mid-range, and base load operations, as well as for industrial cogeneration.

The LM6000's design allows full speed range capability from 50-105% of the rated speed of 3600 RPM. Continuing the tradition of the established record of GE's LM2500, the LM6000 is ideal as a source of drive-power for pipeline compression, offshore platform and gas re-injection, as well as for LNG compressors. The LM6000 was GE's first aeroderivative gas turbine to employ the new Dry Low Emissions (DLE) premixed combustion system. DLE dual fuel, water or steam injection can also be used to achieve low NO<sub>x</sub> emissions.

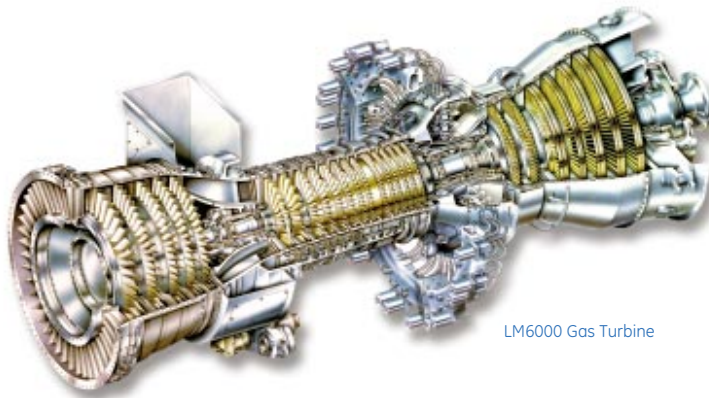

LM6000 Gas Turbine

## GENERAL SPECIFICATIONS

### Compressor

- Two axial compressor (LPC, HPC)
  - LPC five stage
  - HPC fourteen stage
- Pressure ratio 28,5:1

### Combustion

- Annular combustion chamber (30 fuel nozzles)

### Turbine

- Two stage HPT
- Six stage LPT (3600 RPM)

### Package

- Gas Generator, Power Turbine and auxiliary systems mounted on a single base plate
- The enclosure is integral with the base plate providing maximum accessibility for maintenance of the gas turbine and auxiliaries

### Emission Control

- Steam or water injection systems for NO<sub>x</sub> abatement
- Dry Low Emission (DLE) combustion system

# Main Components

## Axial Compressor

The compressor rotor is made of separately forged wheels (all models except the GE5 and part of the GE10 which have a solid forged rotor). Each individual wheel undergoes inspection and is X-rayed for material flaws. In addition, each wheel is balanced individually and the rotor is balanced on three planes. Rabbet fits are used to ensure concentricity and multiple through-bolts secure the wheels to form a correctly pre-stressed assembly. The blades are held in the compressor rotor and stator rings by dovetail platforms. The stainless steel blades provide excellent corrosion resistance and good internal damping characteristics. The large chord, broad-blade compressor blades have low stresses and the unique ability to withstand damage by small foreign objects as well as to maintain high performance in spite of normal wear and contamination. The stator casing is horizontally split for ease of assembly, maintenance and inspection. Iron castings give dimensional and thermal stability to maintain good radial tip clearances for maximum power and efficiency. Several compressor designs are available covering pressure ratios in the 8-17 range and air flows from 20 to 400 Kg/sec with 11-17 stage configurations. The GE5, GE10 and MS5002E compressors have variable geometry, implemented by means of adjustable vanes (inlet guide vanes and first stages stator vanes), in order to provide flow control within the operating range.

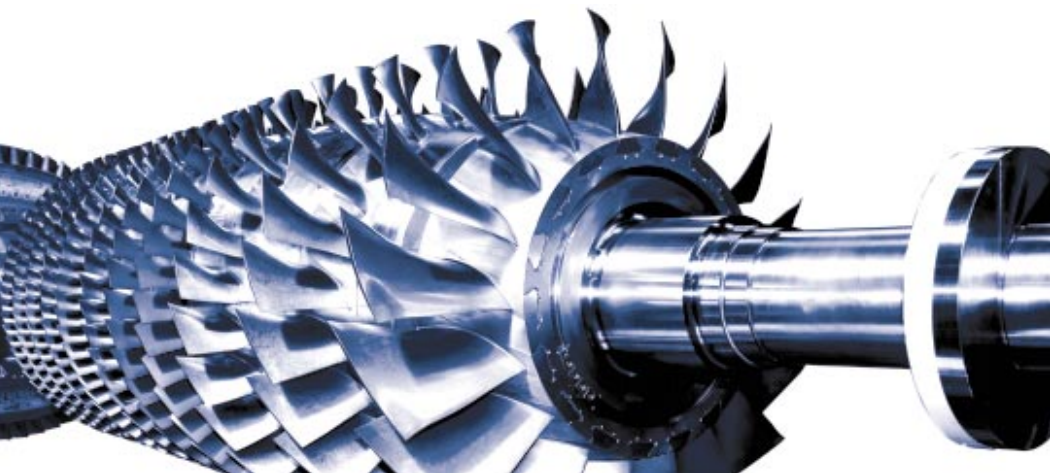



### First Stage Nozzle

The complete first stage nozzle assembly consists of airfoil-shaped vanes which are contained between an inner and an outer sidewall. The design of the nozzle assembly and the arrangement for its support within the turbine shell accommodate the effects of thermal expansion caused by the hot gases and keep the assembly properly aligned in the gas path. Seals in the turbine shell prevent leakage of combustion gases around the nozzle from the inlet to the exhaust. Compressor discharge air is fed to these sealing rings through orifices in the shell. A key feature of the first-stage nozzle is the air-cooled partition which increases nozzle life substantially. Cooled air from the compressor discharge is directed through the body of the individual nozzle partitions and out holes near the trailing edge. This not only cools the metal, but blankets the trailing edge with a film of air. Additionally, relatively thick nozzle partition trailing edges provide increased strength and oxidation resistance, again providing longer nozzle life.

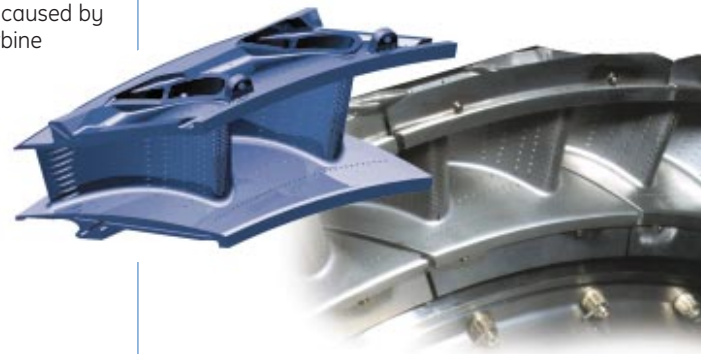

### Buckets and Wheels

The long shank bucket design lowers the turbine wheel rim a substantial distance below the hot gas path. The high thermal resistance of the shank results in a considerable temperature drop between the hot bucket vane and the wheel dovetail, thus reducing temperature levels and gradients in the turbine wheel and the dovetail area where rotating stresses are high. Further wheel protection is provided by radial seals on the first-stage bucket shanks that restrict hot gas leaks into the wheel cavities. Compressor bleed air is used to cool the wheels and maintain relatively low temperature levels.



# Gas Turbine Operability

## Large Operability Window

GE Energy offers a variety of innovative design solutions to maximize the operability window of the Oil & Gas gas turbine fleet. In addition to variable stator vanes and blow-off valves, the design solutions include:

- variable turbine nozzle guide vanes
- a variable bypass combustion chamber
- a high turn-down capability combustion chamber
- CPC optimizing control logic

The various combinations of design solutions are specifically adapted to the demands of the marketplace for each gas turbine model.

For example: The GE10-2 DLN (Dry Low NOx) model utilizes a variable bypass combustion chamber to maintain the optimum flame temperature for low emissions all the way down to 50% load, and the variable nozzle guide vanes of the free power turbine to ensure that the gas generator shaft speed is always at the design value, thereby ensuring maximum output.

The MS5002D instead uses variable nozzle guide vanes to maintain maximum output on the standard model, and maintain the optimum flame temperature for low emissions down to 50% load on the DLN model. They are also used in regenerative cycle applications to maximize the efficiency of the regenerator and hence to maximize fuel economy.

The brand new MS5002E makes use of the DLN2 combustion design used in GE's F-Class machines to ensure low emissions over a range of flame temperatures, thereby delaying the opening of the blow-off valves at part load while maintaining the highest possible efficiency at base-load.

Note that the flexibility given by each of these solutions gives a further performance advantage on cold days with respect to other engines that are forced to open blow-off valves (to meet environmental emissions laws) even at base-load.

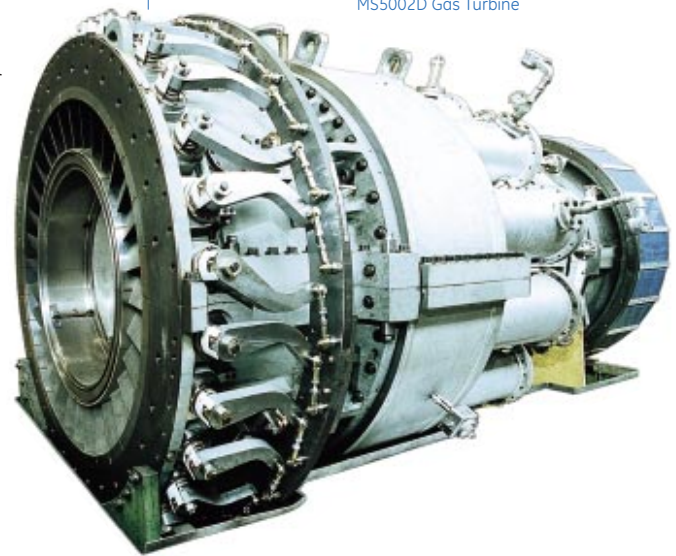

MS5002D Gas Turbine

### CPC Logic

One of the enhancements recently introduced by GE Energy is the Corrected Parameter Control logic (CPC). This type of control philosophy applies principally to mechanical drive units, and consists of an exhaust temperature control curve that self adjusts according to the condition of the inlet filters and actual power turbine speed. This allows the engine to be operated at optimum conditions not only at the nominal point, but over the entire operating envelop of inlet conditions and power turbine speeds. The results of this improvement have already been proven in the field, as shown in the following figure (relating to the test of a GE10-2 unit at various free power turbine speeds). Thanks to the application of CPC logic it has been possible to significantly increase the maximum output without compromising the safe operation of the unit by simply optimizing its operation in real-time.

The variable free power turbine speed element of the CPC logic is provided as standard on the GE5-2, MS5002D DLN and MS5002E models, and on all new GE10-2 units. The possibility to retrofit existing gas turbine models with this solution is also offered.

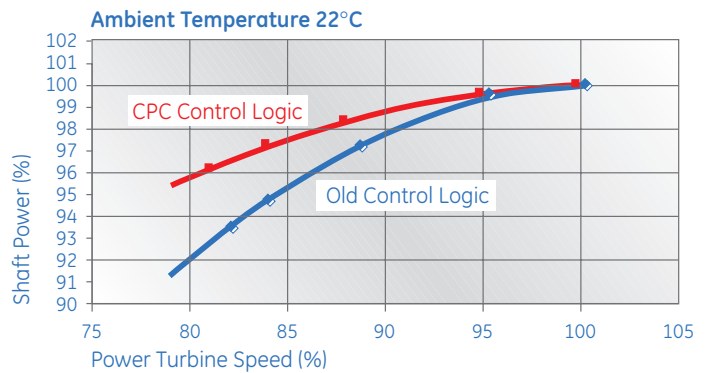

# LNG Exploration and Production, Floating Production Units

## Gas, Water Injection & Gas Storage Units

Gas compression is a critical operation in the Oil & Gas production chain. Therefore reliability is a key factor in the design of GE Energy natural gas compressors.

GE Energy has delivered over 200 compressor trains for gas reinjection and gas storage applications. Of the more than 380 casings supplied, 105 have a design pressure higher than 7,200 psia (500 bar a). Our many years of experience in designing, manufacturing, installing and servicing these machines has validated GE Energy designs and production processes. Reliability of this rotating equipment is directly related to rotor stability and impeller integrity throughout the entire envelope of operating conditions and GE Energy machinery has been successfully proven by long years of service under the challenging conditions found in the Oil & Gas Industry. The high level of power involved in these compression applications requires gas turbines as drivers. GE Energy provides a complete range of mechanical drive gas turbines that are ideally matched to Oil & Gas applications. The extensive use of the GE MS6001 and MS7001EA single shaft gas turbine technology for LNG mechanical drive applications is a result of our plant integration services and the ability to optimize the design of both the gas turbine and the compressor for these applications. The result is flawless performance of turbocompressors that have accumulated more than 100,000 hours of operation in the largest LNG plants in the world. The ability of GE Energy to integrate, test and deliver the entire turbocompressor train is a great advantage to the Customer in terms of optimization of the system performance, delivery time and the efficiency of working with a single supplier.

Hassi R' Mel - Algeria  
Natural Gas Re-injection plant  
36 MS5002 Gas Turbines



Ras Laffan  
Mesaieed - Qatar  
MS5002 Turbo units for  
LNG and Ammonia  
Synthesis

Bongkot Field - Thailand  
Single lift module for  
offshore application  
PGT25 Gas Turbines



Woodside - Australia  
MS5002C LNG main refrigerant  
compressor drive

# Pipeline

## Pipeline Standard Units/Packages

The gas turbines manufactured by GE Energy have features that make them particularly suitable for pipeline compressor applications; GE Energy's pipeline centrifugal compressor line complements its gas turbine line to optimize matching with the gas turbine driver resulting in perfectly integrated gas turbine compressor units.

Specific pipeline service requirements, flexibility in meeting varying operating conditions, reliability, availability and unattended remote control are fully satisfied by these gas turbine and pipeline compressor lines. Direct compressor turbine couplings improve the reliability and efficiency of gas turbine-compressor units reducing the spares inventory. Compact integrated turbine-compressor units make for easy transportation and rapid on-site commissioning. All units are on structural steel base plates, completely shop piped, wired, instrumented tested and ready to be shipped to the site minimizing commissioning time.



Blue Stream Pipeline Project from Turkey to Russia  
PGT25 - BCL406/b



Sbikha - Tunisia  
PGT 25 - PCL603  
Pipeline Compressors

Feriana - Tunisia  
PGT25 - PCL600



Cape Bon - Tunisia  
Trans-Med Pipeline Cape Bon to Sicily  
Head Station 25 MW Gas Turbine  
Driven Booster Compressors.  
MS5002 - BCL404/a



Biskra - Algeria  
OK1 - SP3bis Station  
GE10-2



# Refinery and Petrochemicals

## Downstream Plants

Gas turbine-driven centrifugal compressors are also used in Downstream process industries such as refineries and petrochemical and fertilizer plants that need flexible and reliable compression trains.

GE Energy turbocompressors are individually tailored to meet the customer's performance requirements. They combine in a packaged unit the extensive experience gained by our company on both types of machines and the advantages of a single source of supply--fully integrated auxiliary systems and high operational flexibility and reliability.

Typical applications include:

- Process air centrifugal compressor drive in ammonia synthesis plants
- High power centrifugal or axial compressor drive in Gas to Liquids plants
- Production of compressed air from the turbine axial compressor section and compressor drive in air fractionating processes.

Rhourde Nouss - Algeria  
MS5001 - MS3001 Gas Turbines and  
2BCL 406B Compressors



Mesaieed - Qatar  
MS5001 Turbogenerator units  
for Fertilizer plant



Livorno - Italy  
MS9001 Turbogenerator units  
for Refinery plant



# Test Facilities

GE Energy carries out mechanical tests on all its gas turbines. Complete turbocompressors and turbogenerators, including all auxiliary equipment, can be full-load tested on outdoor test beds complying with API, ASME, VDI and ISO international standards at the Florence or Massa plants. Even complete modules can be tested at the Massa plant and then shipped without being this assembled because of its proximity to the Massa harbor. The test beds are equipped with computer Data Acquisition Systems capable of collecting thermodynamic and mechanical data and computing in real time. Test facilities include a high pressure feed system for gas mixtures (inert and flammable gases), a gas chromatograph for gas analysis, a 60 Hz generator, low and high pressure gas coolers, and steam and lube oil supply. The cooling towers allow closed-loop tests up to 130 MW. GE Energy also tests complete plants on site upon customer request.

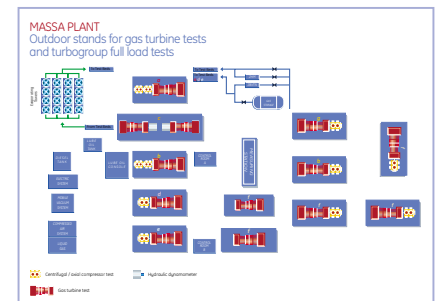
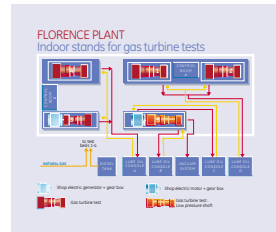
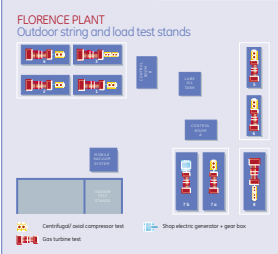
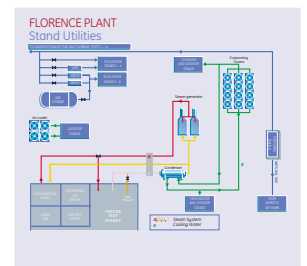

# Service

GE Energy provides a complete set of services to support the entire gas turbine product line. We offer an extensive portfolio of proactive and interactive service products such as condition-based maintenance and long term service agreements complementing the traditional service offerings of OEM spare parts, repairs, and field services.

Our innovations are not limited to mechanical engineering. We have developed business solutions such as remote monitoring & diagnostics to help drive customer value by providing higher equipment reliability, availability, and productivity at a predictable cost.

Other advanced information-based developments include electronic parts catalogs, and e-commerce solutions.

Global Services engineers are backed up by the new product design engineering groups of GE Energy and by the GE Global Research Center --hundreds of creative minds working to provide the high-tech products and business solutions for the 21<sup>st</sup> century.



# Training

GE Energy offers Training for the Operation and Maintenance of our complete line of machinery and equipment.

This Training can be provided either at the client's site or at the Learning Center located at GE Energy headquarters in Florence, Italy. Instructors are field-seasoned experts who combine their understanding of theory with practical experience.

The quality training that they provide is a prerequisite for improving the skills of operating and maintenance personnel skills, to assure safety, and superior equipment efficiency and availability. Courses and and documentation are designed to meet Customer needs, focusing on the GE Energy machinery and equipment actually installed at their sites.

Traditional training tools are augmented with computer-based training and interactive multimedia technology. Courses and technical literature can be provided in a variety of languages.



## CENTER OF EXCELLENCE FOR TRAINING

### Florence Learning Center Facilities:

- 5600 m<sup>2</sup> of Space
- More than 20 Training Rooms
- Speedtronic Mark V & Mark VI
- Bently Nevada Simulators
- Laboratories
- Multimedia Rooms
- Conference Center
- Auditorium Seating for 230 (under completion)















### TRAINING SOLUTIONS:

- For all level in your organization
- Tailored for your specific needs
- Pre-scheduled offerings or on request
- Provided in various languages
- Formal classroom training and interactive learning

### COVERED EQUIPMENT















Nuovo Pignone, Thermodyn, Rotoflow, Bently Nevada and other GE Energy equipment.















## Generator Drive (ISO conditions - natural gas - electrical generator terminals)

	ISO RATED POWER kW	HEAT RATE kJ/kWh	EFFIC. %	PRESSURE RATIO	EXHAUST FLOW		TURBINE SPEED RPM	EXHAUST TEMPERATURE	
					kg/sec	lbs/sec		°C	°F
 PGT5	5,220	13,422	26.8	9.1	24.6	54.2	10,290	523	973
 GE5	5,500	11,740	30.7	14.8	19.6	43.1	16,630	574	1,065
 PGT10	10,220	11,540	31.2	13.8	42.3	93.3	7,900	488	910
 GE10	11,250	11,481	31.4	15.5	47.5	104.7	11,000	482	900
 PGT16	13,720	10,300	35.0	20.2	47.3	104.3	7,900	491	919
 PGT20	17,464	10,238	35.2	15.7	62.5	137.7	6,500	475	887
 PGT25	22,417	9,919	36.3	17.9	68.9	151.9	6,500	525	976
 PGT25+	30,226	9,084	39.6	21.6	84.3	185.9	6,100	500	931
 LM6000	42,703	8,770	41.0	27.9	125.8	288.8	3,600	452	840
 MS5001	26,830	12,687	28.4	10.5	125.2	276.1	5,094	483	901
 MS5002E	31,100	10,285	35.0	17.0	102.0	225.0	5,714	511	952
 MS6001B	42,100	11,230	32.1	12.2	141.1	311.0	5,163	548	1,026
 MS7001EA	85,400	10,990	32.7	12.6	292.0	643.0	3,600	537	998
 MS9001E	126,100	10,650	33.8	12.6	418.0	921.0	3,000	543	1,009



## Mechanical Drive (ISO conditions - natural gas - shaft output)

	ISO RATED POWER		HEAT RATE		EFFIC. %	PRESSURE RATIO	EXHAUST FLOW		TURBINE SPEED RPM	EXHAUST TEMPERATURE	
	kW	shp	kJ/kWh	btu/shp-h			kg/sec	lbs/sec		°C	°F
 PGT5	5,440	7,295	13,470	9,523	26.7	8.6	25.8	56.9	10,290	533	991
 GE5	5,600	7,510	11,429	8,080	31.5	14.6	20.0	44.2	12,500	556	1,032
 PGT10	10,660	14,295	11,060	7,819	32.5	13.8	42.3	93.3	7,900	488	910
 GE10	11,982	16,068	10,822	7,651	33.3	15.5	46.9	103.3	7,900	480	896
 PGT16	14,240	19,096	9,930	7,020	36.3	20.2	47.3	104.3	7,900	491	919
 PGT20	18,121	24,300	9,867	6,975	36.5	15.7	62.6	137.9	6,500	475	887
 PGT25	23,261	31,193	9,560	6,759	37.7	17.9	68.9	151.9	6,500	525	976
 PGT25+	31,364	42,060	8,754	6,189	41.1	21.6	84.3	185.8	6,100	500	931
 LM6000	43,679	58,575	8,600	6,080	41.9	27.9	126.5	280.0	3,600	455	853
 MS5002C	28,340	38,005	12,470	8,816	28.8	8.8	123.4	274.1	4,670	517	963
 MS5002E	32,000	42,913	10,000	7,070	36.0	17.0	102.0	225.0	5,714	511	952
 MS5002D	32,580	43,690	12,239	8,653	29.4	10.8	141.4	311.7	4,670	509	948
 MS6001B	43,530	58,380	10,825	7,653	33.3	12.0	140.0	309.0	5,111	544	1,011
 MS7001EA	87,300	117,071	10,870	7,685	33.1	12.7	302.0	665.8	3,600	535	995
 MS9001E	130,100	174,467	10,400	7,353	34.6	12.6	421.0	928.0	3,000	540	1,004

		GENERATOR DRIVE		MECHANICAL DRIVE	
		Approx. Weight (**)	Approx. Dimensions (**)	Approx. Weight (**)	Approx. Dimensions (**)
		Kg.	m.	Kg.	m.
	PGT5	28,000	8.5 × 2.5 × 3.0	30,000	7.7 × 2.5 × 4.3
	GE5	23,900	5.9 × 2.5 × 3.0(***)	23,000	7.8 × 2.5 × 3(***)
	PGT10	27,000	8.1 × 2.5 × 4.0(***)	32,000	9.1 × 2.5 × 4.0(***)
	GE10	34,000	9.0 × 2.5 × 6.0	38,000	10.5 × 2.5 × 6.0
	PGT16	19,000	8.1 × 2.5 × 3.8	19,000	8.1 × 2.5 × 3.8
	PGT20	37,650	9.1 × 3.5 × 3.5	37,650	9.1 × 3.5 × 3.5
	PGT25	37,650	9.1 × 3.5 × 3.5	37,650	9.1 × 3.5 × 3.5
	PGT25+	30,750	6.5 × 3.6 × 3.9	30,750	6.5 × 3.6 × 3.9
	LM6000	31,000	9.3 × 4.2 × 4.4	31,000	9.3 × 4.2 × 4.4
	MS5001	87,430	11.6 × 3.2 × 3.7		
	MS5002C/D			110,000(*)	15.0 × 3.2 × 3.8(*)
	MS5002E	117,000	17 × 3.4 × 4	117,000	17 × 3.4 × 4
	MS6001B	96,000(*)	15.9 × 3.2 × 3.8(*)	96,000(*)	15.9 × 3.2 × 3.8(*)
	MS7001EA	121,000	11.6 × 3.3 × 3.8	121,000(*)	11.6 × 3.3 × 3.8(*)
	MS9001E	217,500(*)	22.1 × 4.5 × 6.3(*)		

(\*) including auxiliary skid  
(\*\*) gas turbine skid without enclosure  
(\*\*\*) gas turbine package

Nuovo Pignone S.p.A.  
via F. Matteucci, 2  
50127 Florence - Italy  
T +39 055 423211  
F +39 055 4232800  
[www.geoilandgas.com](http://www.geoilandgas.com)



GE imagination at work

COMK/MARK 769/II - Designed by: Studio Tre Fasi  
Printed by: Sagraf - 7-2005  
©2005 Nuovo Pignone S.p.A. all rights reserved