

Becker* 35000 and 36000 Series V-0 Control Valves





GE's Becker V-0 Control Valve is a segmented type rotary control valve designed for mild duty natural gas regulation. The V-0 features a high capacity, cost effective design in a very compact package.

The 35000 Series V-0 valve incorporates flangeless end connections for installation between flanges. The 36000 Series V-0 valve incorporates raised face flange end connections in accordance with ISA S75.04. The 35000 Series valves are offered in 150, 300, and 600 ANSI ratings and the 36000 Series valves are offered in 150 and 300 ANSI ratings. The V-0 Control valve utilizes the Becker RSD Rotary Spring and Diaphragm actuators. When paired with GE environmentally friendly control instrumentation, the V-0 is the ideal high capacity valve for mild duty pressure and flow regulation, and on/off service in natural gas piping systems.

Features

- High capacity ball valve design allows low wide open pressure differential
- Extended turndown in excess of 300:1 with v-notch segmented ball
- Soft seat design for bubble tight shutoff or stainless steel seat for erosive process
- Spring and diaphragm actuators require low supply pressure and reduced transient consumption
- Easy maintenance minimizes downtime
- Versatile design allows for simple field actuator mounting change
- Becker ZERO BLEED* instrumentation reduces costly atmospheric gas emissions in steady state
- Proven Becker VRP Valve Regulator Pilot and DNGP Digital Natural Gas Positioner offer accurate steady-state control
- Use in control or ON/OFF applications



Simple Rugged Versatile Design

Flanged or Flangeless Design

Integral flange (150 and 300 Class) and flangeless (150, 300, and 600 Class) end connections available

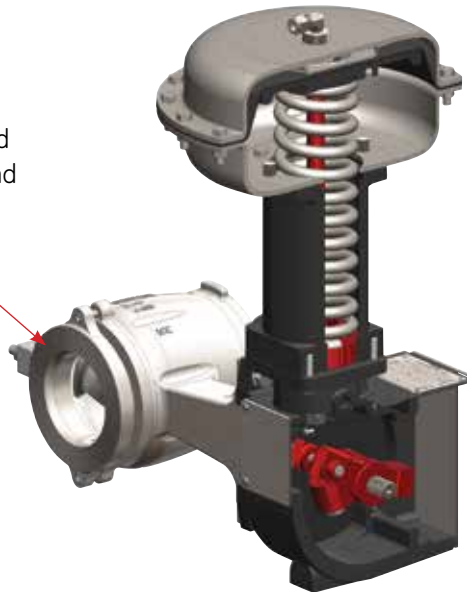

Spring and Diaphragm Actuator

Large diaphragm area requires low supply pressure and low transient consumption. Spring loaded fail safe is easily field reversible

High Turndown

The segmented ball design with the v-notch characteristic offers high wide-open capacity and optimal low-end control resulting in total turndown in excess of 300:1

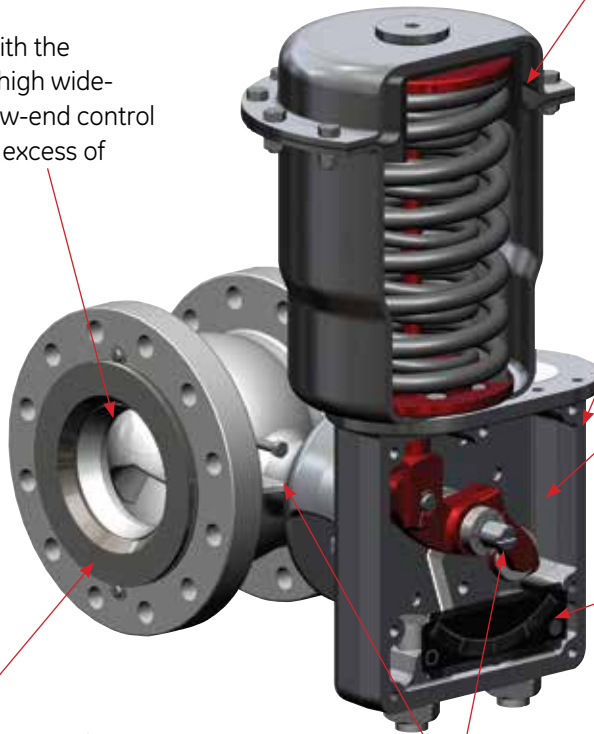

Simple Enclosed Housing

Enclosed actuator housing protects linkage from the elements and is safer for station personnel

Blowout-Proof Shaft

The shaft is designed so that it can not blow out, even with the actuator and packing follower removed

Position Indication

Visible rotary indicator allows quick visual inspection of valve position

Soft or Metal Seat Design

Easily interchangeable soft seat (standard) offering Class VI shutoff, or stainless steel seat (optional) offering Class IV shutoff

Splined Stem Connections

A durable and accurate involute spline connects the stem to the ball and torque arm. Unlike pins or keys, concentrated stresses are avoided to ensure long trouble-free service

High Capacity with Optimal Low-End Control

Flanged Body Design (Available in Classes 150 and 300)

Valve Size		V-0 Control Valve (Degrees Open)								
(in)	(mm)	10	20	30	40	50	60	70	80	90
1	25	0.2	1.2	2.9	5.2	8.2	12.1	17.3	25.6	55.0
1.5	40	0.4	2.7	6.5	11.9	18.8	27.5	39.4	58.1	125
2	50	0.5	3.7	8.8	16.1	25.5	37.4	53.5	79.0	170
3	80	1.3	9.4	22.9	41.8	66.0	96.8	138.6	205	440
4	100	2.2	15.9	38.5	70.3	111	163	233	344	740
6	150	3.8	26.9	65	119	188	275	394	581	1250
8	200	5.6	40	97	177	279	409	586	865	1860
10	250	9	64.9	157	287	453	664	951	1404	3020
12	300	13.2	95	229	418	660	968	1386	2046	4400

Flangeless Body Design (Available in Classes 150, 300 and 600)

Valve Size		V-0 Control Valve (Degrees Open)								
(in)	(mm)	10	20	30	40	50	60	70	80	90
2	50	0.3	4.7	12.7	23.3	39.0	58.2	81.5	112	163
3	80	1.5	7.4	22.3	44.6	73.7	114	164	242	372
4	100	2.3	17.3	40.3	74.2	121	178	247	371	575
6	150	4.6	30.2	78.9	148	231	331	463	664	1160
8	200	5.7	47.8	120	225	354	512	749	1180	1770

Capacity Curve for 6" (150 mm) Flangeless V-0

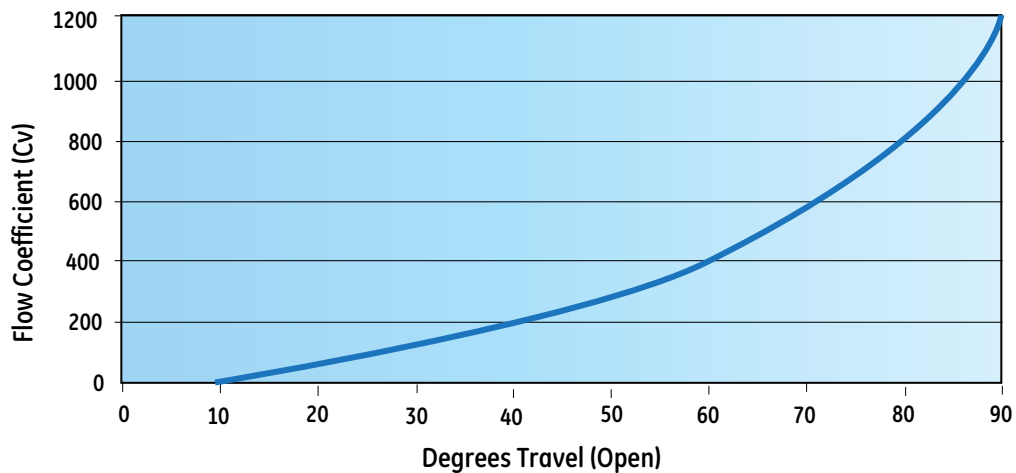

High Rangeability

The V-0 Control Valve offers a modified equal percentage capacity curve allowing optimal control at both the low end and high wide-open capacity

Equipped with Environmentally Friendly Instrumentation

Pressure Control with VRP Valve Regulator Pilot

The Becker Model VRP-SB-CH Single-Acting Pilot provides pressure control when utilized with the V-0 Control Valve. The VRP-SB-CH pilot measures process sensing pressure and positions the single-acting V-0 actuator to maintain the pressure setpoint. The VRP-SB-CH pilot may be utilized for pressure control applications with setpoints ranging from 1.0 psig (6.9 kPa) to 1480 psig (10204 kPa). The VRP-SB-CH pilot features ZERO BLEED™ in steady state.

- Purely pneumatic pressure control
- ZERO BLEED™ technology eliminates atmospheric emissions in steady state
- Design specifically suited for natural gas production, midstream, distribution, and transmission
- Setpoint ranges from 1 to 1480 psig
- Rugged design is vibration resistant and suitable for demanding pipeline applications



Flow or Pressure Control with DNGP Digital Natural Gas Positioner

The Becker DNGP Digital Natural Gas Positioner is used with the V-0 control valve to provide an accurate valve stem position that is proportional to the electronic command input signal received from an electronic controller. The DNGP eliminates the need for an I/P transducer and features ZERO BLEED™ consumption at steady state. Additionally, the DNGP features easy, menu driven setup along with PC interfaced diagnostic and setup features. Most importantly, the DNGP offers multiple fail safe modes to protect your gas pipeline.

- 4-20 mA analog and 12 or 24 VDC pulse input
- ZERO BLEED™ technology eliminates atmospheric emissions in steady state
- Design specifically suited for natural gas production, midstream, distribution, and transmission
- Explosion proof design may be installed in hazardous locations
- Illuminated display and navigational menus for easy field configuration
- Split range control for multiple runs
- Push-button manual local positioning of valve



ON/OFF Over/Under-Pressure Protection with VRP-SB-GAP Controller

The Becker Model VRP-SB-GAP Single-Acting Controller provides on-off control when utilized with the V-0 Control Valve. The VRP-SB-GAP controller measures the process sensing pressure and closes the actuated valve upon pressure rising to the high pressure setpoint. Conversely, VRP-SB-GAP controller will re-open the actuated valve upon pressure falling to the low pressure setpoint. The action of the VRP-SB-GAP controller may be reversed to open an actuated valve upon rising pressure while closing on falling pressure. The VRP-SB-GAP controller may be utilized for gap control applications with setpoints ranging from 1.0 psig (6.9 kPa) to 1480 psig (10204 kPa). The VRP-SB-GAP controller features ZERO BLEED™ in steady state.

- Purely pneumatic over/under-pressure protection for on/off applications
- Automatic reset when trip condition removed
- ZERO BLEED™ technology eliminates atmospheric emissions in steady state
- Design specifically suited for natural gas production, midstream, distribution, and transmission
- Setpoint ranges from 1 to 1480 psig
- Rugged design is vibration resistant and suitable for demanding pipeline applications
- Easy, intuitive adjustment and maintenance techniques greatly minimize training

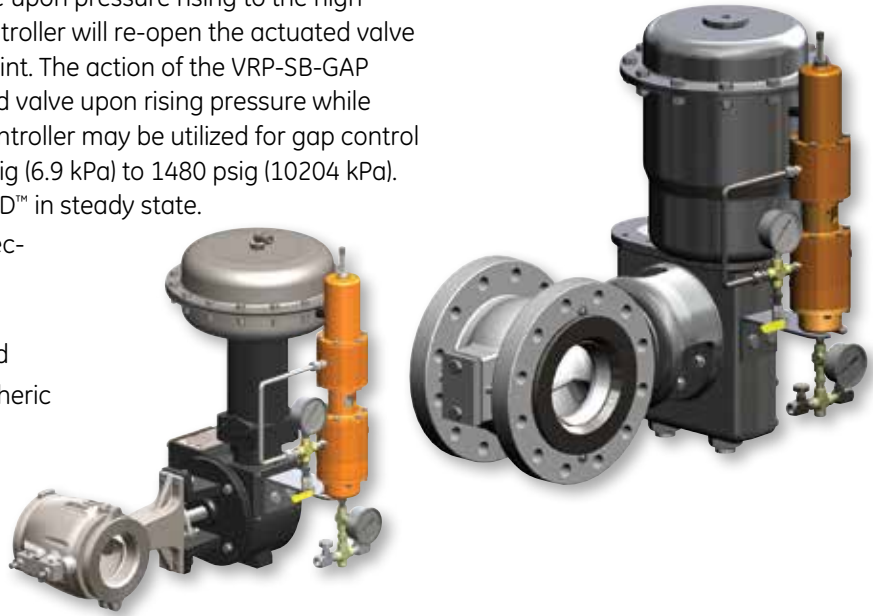

Specifications

35000 and 36000 Series V-0 Control Valve

Classification	Rotary Control Valve
Valve Type	Segmented Ball Valve
Applications	Monitoring, mild service, or on/off applications
Shut Off Class	Class VI with soft seats (standard) or Class IV with metal seats (optional)
Flow Characteristics	Modified Equal Percentage (high gain)

Range of Product

Size Range	
Flange End	1" (25 mm) to 12" (300 mm)
Flangeless	2" (50 mm) to 8" (200 mm)
Pressure Ratings	
Flange End	150 and 300 ANSI
Flangeless	150, 300 and 600 ANSI
End Connections	RFFE, Flangeless
Compatible Actuators	Becker RSD Series - Rotary Spring and Diaphragm

Materials of Construction

Body Material	
Flange End	ASTM A216 Gr WCB Carbon Steel
Flangeless	ASTM A352 Gr LCC Carbon Steel
Ball Material	ASTM A351 Gr CG8M Type 317
Seat Seal Material	
Flange End	PTFE (standard soft seat), 317 SS (metal seat)
Flangeless	TFE (standard soft seat), 316 SS (metal seat)
Prep/Coating	Sandblast per SP-10 and standard Becker topcoat

General Design Specifications

Maximum Control Cv	90% of Maximum Cv
Minimum Control Cv	0.33% of Maximum Cv
Maximum Noise	100 dBA
Pipe Velocity (Gas)	100 ft/sec
Pipe Velocity (Liquid)	30 ft/sec
Face to Face	Conforms to ISA Standard S75.04
Operating Temperature	
Flange End	soft seat: -20°F to 425°F (-29°C to 218°C) metal seat: -20°F to 500°F (-29°C to 260°C)
Flangeless	soft seat: -50°F to 450°F (-46°C to 232°C) metal seat: -50°F to 550°F (-46°C to 287°C)

35000 Series Flangeless V-0 Valve Dimensions

35000 Series V-0 Valve Dimensions (in)											
Valve Size	Actuator Size	Weight lbs	A	B	C	D	E	F	G	H	I
2 (50)	30	86	17.87	21.45	13.31	1.31	4.38	4.56	11.38	11.38	4.88
2 (50)	40	115	24.38	22.26	19.88	2.12	4.38	4.50	13.12	11.32	4.88
2 (50)	60	218	34.25	25.94	29.50	2.50	4.38	4.75	18.62	12.25	4.88
3 (80)	30	100	17.87	24.51	13.31	1.31	5.50	4.56	11.38	13.32	6.50
3 (80)	40	129	24.38	25.32	19.88	2.12	5.50	4.50	13.12	13.26	6.50
3 (80)	60	232	34.25	29.00	29.50	2.50	5.50	4.75	18.62	14.19	6.50
4 (100)	40	149	24.38	26.63	19.88	2.12	6.19	4.50	13.12	13.88	7.62
4 (100)	60	252	34.25	30.31	29.50	2.50	6.19	4.75	18.62	14.81	7.62
6 (150)	60	282	34.25	33.06	29.50	2.50	7.44	4.75	18.62	16.31	9.00
8 (200)	60	332	34.25	36.62	29.50	2.50	9.12	4.75	18.62	18.19	9.56

35000 Series V-0 Valve Dimensions (mm)											
Valve Size	Actuator Size	Weight kg	A	B	C	D	E	F	G	H	I
2 (50)	30	39	454	545	338	33	111	116	289	289	124
2 (50)	40	52	619	565	505	54	111	114	333	288	124
2 (50)	60	99	870	659	749	64	111	121	473	311	124
3 (80)	30	45	454	623	338	33	140	116	289	338	165
3 (80)	40	59	619	643	505	54	140	114	333	337	165
3 (80)	60	105	870	737	749	64	140	121	473	360	165
4 (100)	40	68	619	676	505	54	157	114	333	353	194
4 (100)	60	115	870	770	749	64	157	121	473	376	194
6 (150)	60	128	870	840	749	64	189	121	473	414	229
8 (200)	60	151	870	930	749	64	232	121	473	462	243

35000 Series Valve Tie Rod Length (in)			
Valve Size	Class 150	Class 300	Class 600
2 (50)	8.25	8.50	9.25
3 (80)	10.12	11.12	11.50
4 (100)	11.44	12.12	13.62
6 (150)	13.62	14.38	16.50
8 (200)	13.62	15.38	17.12

35000 Series Valve Tie Rod Length (mm)			
Valve Size	Class 150	Class 300	Class 600
2 (50)	210	216	235
3 (80)	257	282	292
4 (100)	291	308	346
6 (150)	346	365	419
8 (200)	346	391	435

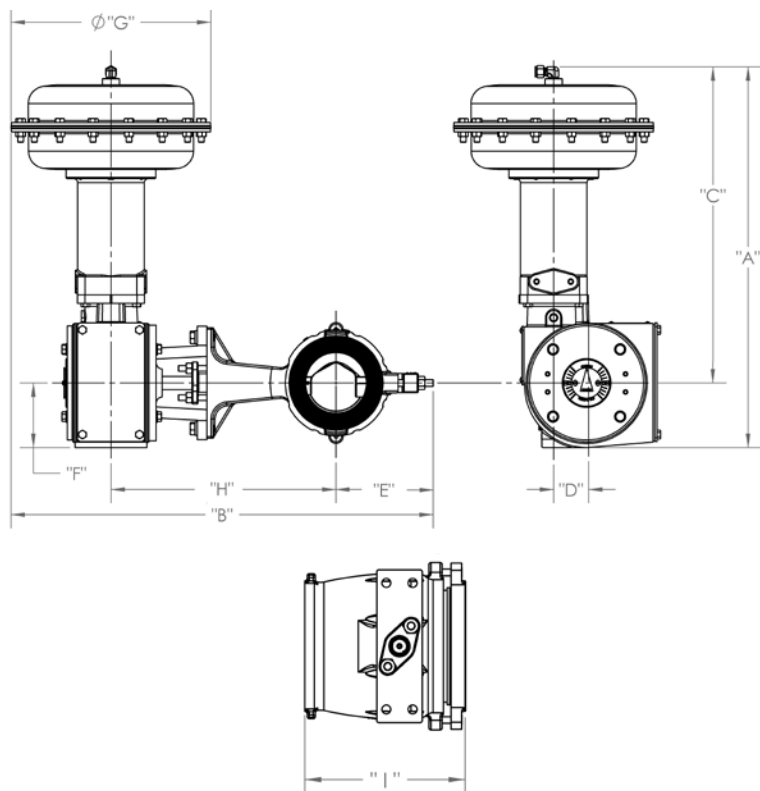

36000 Series Flanged V-0 Valve Dimensions

Actuator Model 33, Size AC – inches [millimeters]

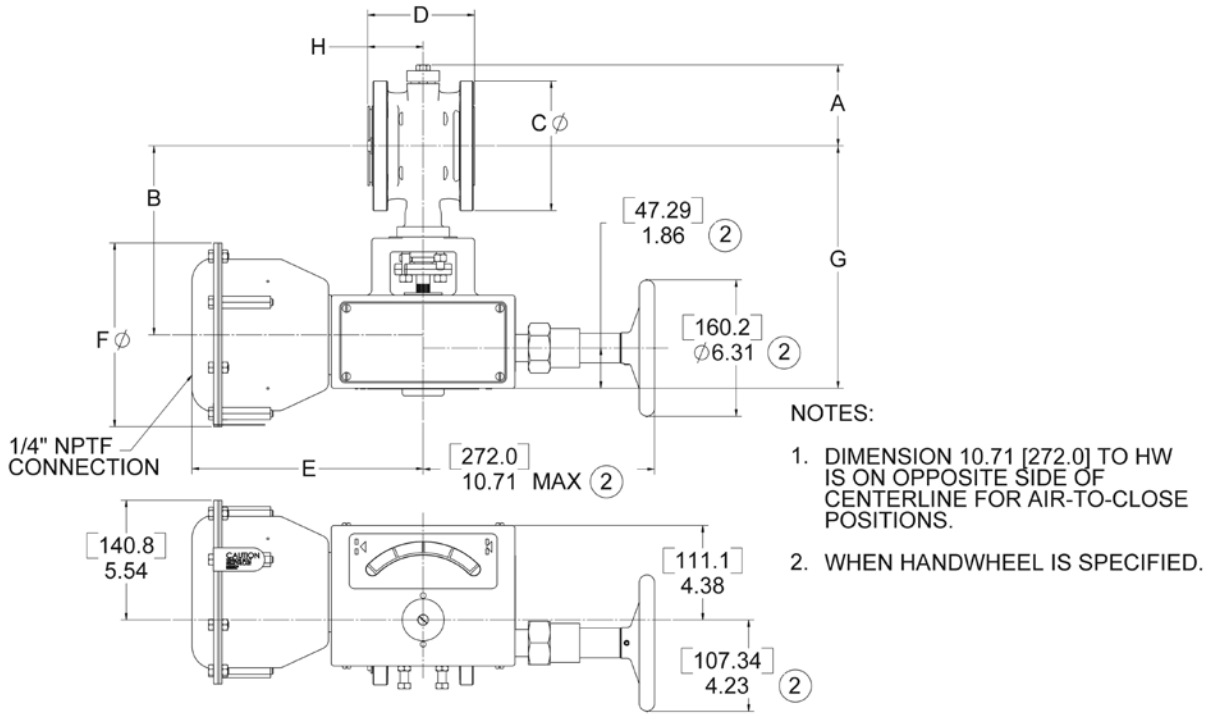

Actuator Model 33, Size B and C – inches [millimeters]

NOTES:

- DIMENSION 13.73 [348.07] TO HW IS ON OPPOSITE SIDE OF CENTERLINE FOR AIR-TO-CLOSE POSITIONS.
- WHEN HANDWHEEL IS SPECIFIED.

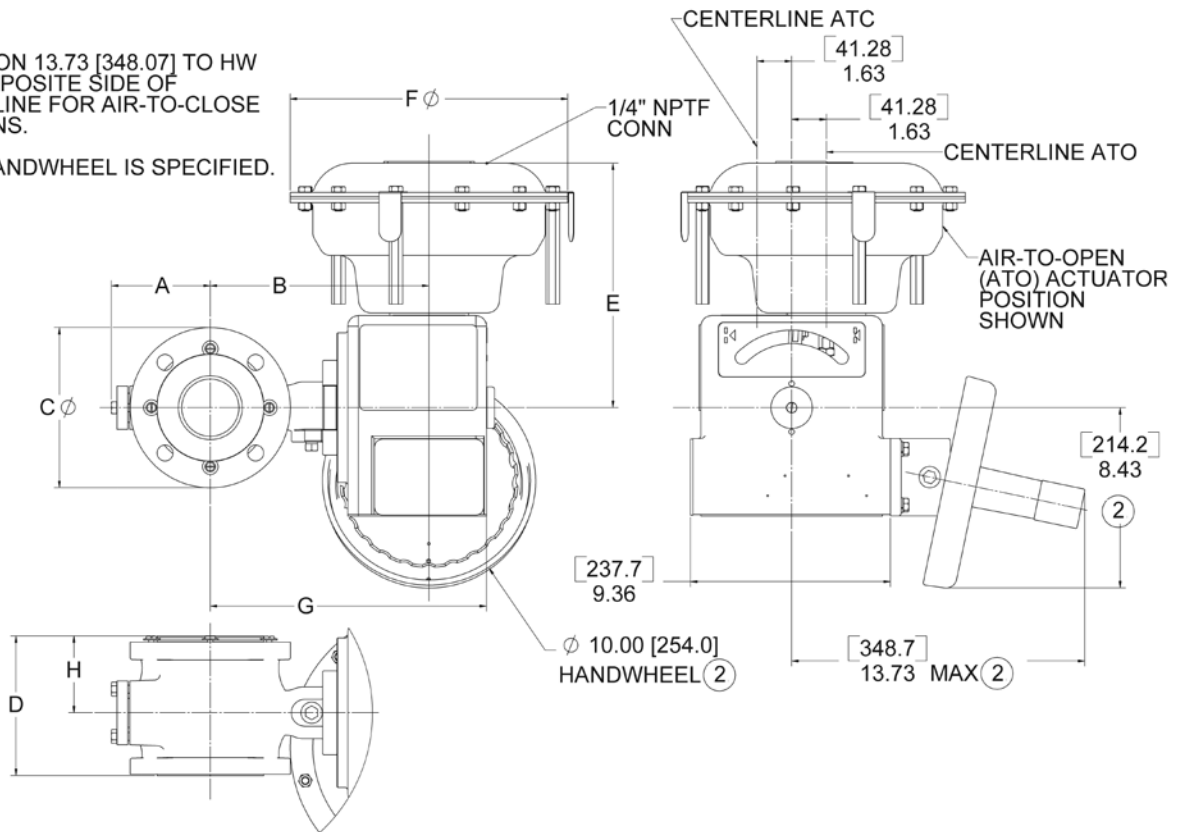

36000 Series Flanged V-0 Valve Dimensions (in)

Valve Size		Actuator Size		A		B	C ⁽¹⁾		Face-to-Face D	E	F	G	Center-to-Face H
in.	DN	Size	Sq. In.	ANSI 150	ANSI 300		ANSI 150	ANSI 300	Standard ISA S75.04 ⁽²⁾				Standard ISA S75.04 ⁽²⁾
1	25	AC	30	2.74	2.74	8.06	4.25	4.88	4.00	10.70	8.50	10.53	2.12
1.5	40	AC	30	3.13	4.08	8.33	5.00	6.12	4.47	10.70	8.50	10.80	2.43
2	50	AC	30	3.92	5.05	8.74	6.00	6.50	4.93	10.70	8.50	11.21	2.56
		B	70	3.92	5.05	8.52	6.00	6.50	4.93	11.45	13.00	11.21	2.56
3	80	B	70	4.64	4.64	10.24	7.50	8.25	6.54	11.45	13.00	12.93	3.59
		C	140	4.64	4.64	10.24	7.50	8.25	6.54	15.07	17.50	12.93	3.59
4	100	B	70	5.48	5.48	10.87	9.00	10.00	7.61	11.45	13.00	13.56	3.95
		C	140	5.48	5.48	10.87	9.00	10.00	7.61	15.07	17.50	13.56	3.95
6	150	C	140	6.76	6.76	12.09	11.00	12.50	8.99	15.07	17.50	14.78	4.85
8	200	C	140	7.88	7.88	13.81	13.50	15.00	9.59	15.07	17.50	16.50	5.03
10	250	C	140	9.46	9.46	15.75	16.00	17.50	11.69	15.07	17.50	18.44	6.09
12	300	C	140	10.63	10.63	16.92	19.00	20.50	13.33	15.07	17.50	19.61	7.52

36000 Series V-0 Valve Dimensions (mm)

Valve Size		Actuator Size		A		B	C ⁽¹⁾		Face-to-Face D	E	F	G	Center-to-Face H
in.	DN	Size	Sq. cm	ANSI 150	ANSI 300		ANSI 150	ANSI 300	Standard ISA 75.04 ⁽²⁾				Standard ISA S75.04 ⁽²⁾
1	25	AC	194	69.60	69.60	204.72	107.95	123.95	101.60	271.78	215.90	267.46	53.85
1.5	40	AC	194	79.50	103.63	211.58	127.00	155.45	113.54	271.78	215.90	274.32	61.72
2	50	AC	194	99.57	128.27	222.00	152.40	165.10	125.22	271.78	215.90	284.73	65.02
		B	452	99.57	128.27	216.41	152.40	165.10	125.22	290.83	330.20	284.73	65.02
3	80	B	452	117.86	117.86	260.10	190.50	209.55	166.12	290.83	330.20	328.42	91.19
		C	903	117.86	117.86	260.10	190.50	209.55	166.12	382.78	444.50	328.42	91.19
4	100	B	452	139.19	139.19	276.10	228.60	254.00	193.29	290.83	330.20	344.42	100.33
		C	903	139.19	139.19	276.10	228.60	254.00	193.29	382.78	444.50	344.42	100.33
6	150	C	903	171.70	171.70	307.09	279.40	317.50	228.35	382.78	444.50	375.41	123.19
8	200	C	903	200.15	200.15	350.77	342.90	381.00	243.59	382.78	444.50	419.10	127.76
10	250	C	903	240.28	240.28	400.05	406.40	444.50	296.93	382.78	444.50	468.38	154.69
12	300	C	903	270.00	270.00	429.77	482.60	520.70	338.58	382.78	444.50	498.09	191.01

Notes:

1. Conforms to ASME/ANSI Standard B16.5 - 1996 "Pipe Flanges and Flange Fittings"
2. Conforms to ISA Standard S75.04
3. Conforms to ASME Standard B16.10 - 1992 (formerly ANSI Standard B16.10 - 1973)
Short Pattern Ball. Available for ANSI 150 Class Valves ONLY

36000 Series Flanged V-0 Valve Dimensions (continued)

Assembly Weights

Valve Size		Actuator		Valve and Actuator Assembly Weights (without Manual Override)				Manual Override	
				Standard ISA S75.04 Face-to-Face					
				ANSI Class 150 Flanged		ANSI Class 300 Flanged		Add to Valve/Actuator Weight	
in	DN	Model	Size	lbs	Kg	lbs	Kg	lbs	Kg
1	25	33	AC	50	22	53	24	7	3
1.5	40	33	AC	54	24	61	27	7	3
2	50	33	AC	60	27	81	37	7	3
		33	B	101	46	122	55	27	12
3	80	33	B	124	56	134	61	27	12
		33	C	182	82	192	87	27	12
		31/32	D	227	103	237	107	12	5
4	100	33	B	147	67	166	75	27	12
		33	C	205	93	224	101	27	12
		31/32	D	250	113	269	122	12	5
6	150	33	C	250	114	288	131	27	12
		31/32	D	295	134	333	151	12	5
8	200	33	C	303	137	359	163	27	12
		31/32	D	348	158	404	183	12	5
10	250	33	C	393	178	416	189	27	12
		31/32	D	438	199	461	209	12	5
12	300	33	C	520	236	540	245	27	12
		31/32	D	565	256	585	265	12	5



GE Oil & Gas
16250 Port Northwest
Houston TX 77041
+1 866 754 3562
www.geoilandgas.com

*Denotes trademark of General Electric Company.
© 2014 General Electric Company. All Rights Reserved.
GEA31409 09/2014