

GRD TIER 3

Diesel Mechanical Grader

Technical Specifications Guide



Vehicles that show their best advantage when mine conditions are most difficult.

GRD TIER 3

Diesel Mechanical Grader

Product Overview

The Industrea Mining Equipment Grader is a fully equipped grader designed for the confines and environment of an underground coal mine.

The Industrea Mining Equipment Grader features industry leading Human Factor design that allows safe comfortable operation for extended periods. The Grader has the correct mass, tractive effort and tools to fair and maintain roadways in an underground coal mine.



Installed **Tier 3** Diesel Engine System.

Specifications

Overall Length	9335 mm
Overall Width	2530 mm
Overall Height	1830/1930 mm
Wheel base	5733 mm
Mold board length	3658 mm
Installed Power	82 kW
Tare Weight	16.75 T
Draw Bar Pull	11 T
Grade speed	4 – 9 km/hr
Travel speed	20 km/hr

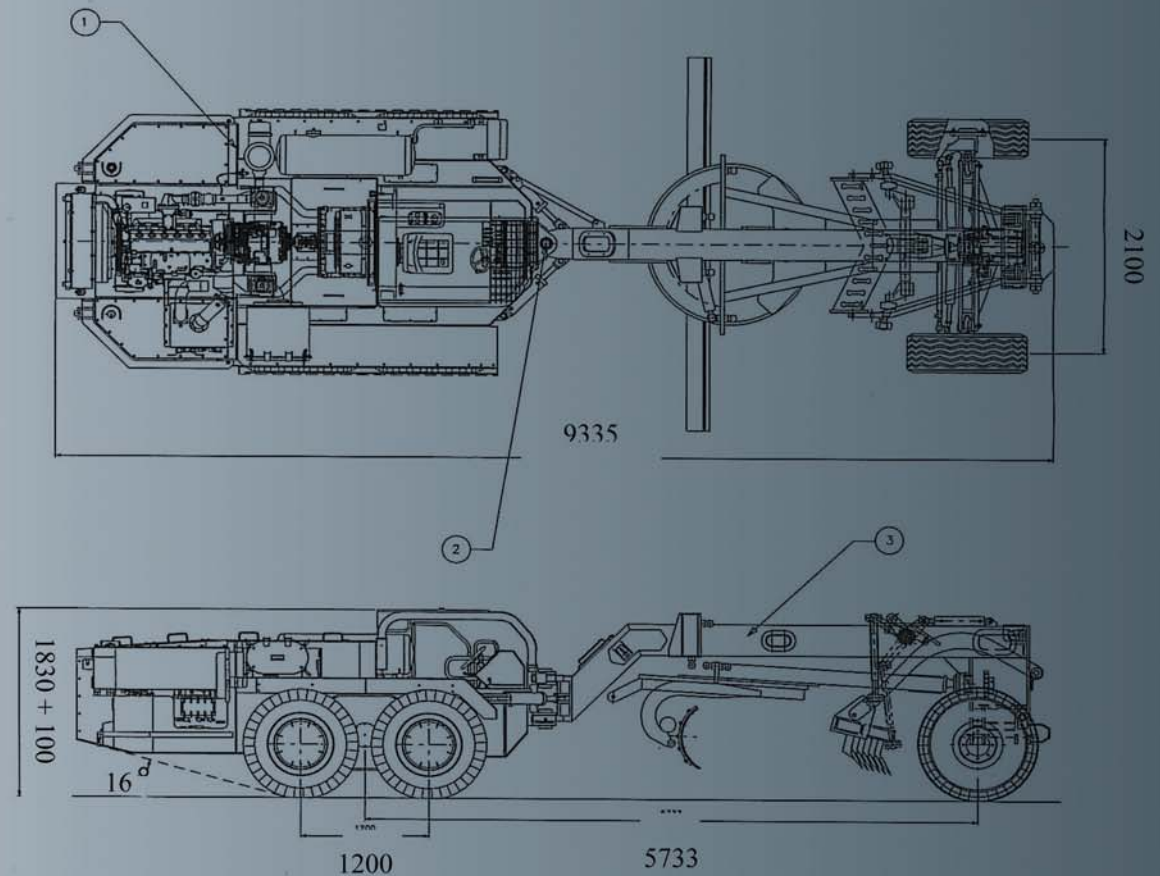

Vehicles that show their best advantage when mine conditions are most difficult.

www.industrea.com.au



Industrea Mining Equipment

63 Bonville Avenue
Thornton, New South Wales
Australia, 2322

t +61 2 4014 8500

f +61 2 4014 8599

w www.industrea.com.au