

GE
Power Conversion

MV7000

Reliable, high performance
medium voltage drive



imagination at work

ecomagination

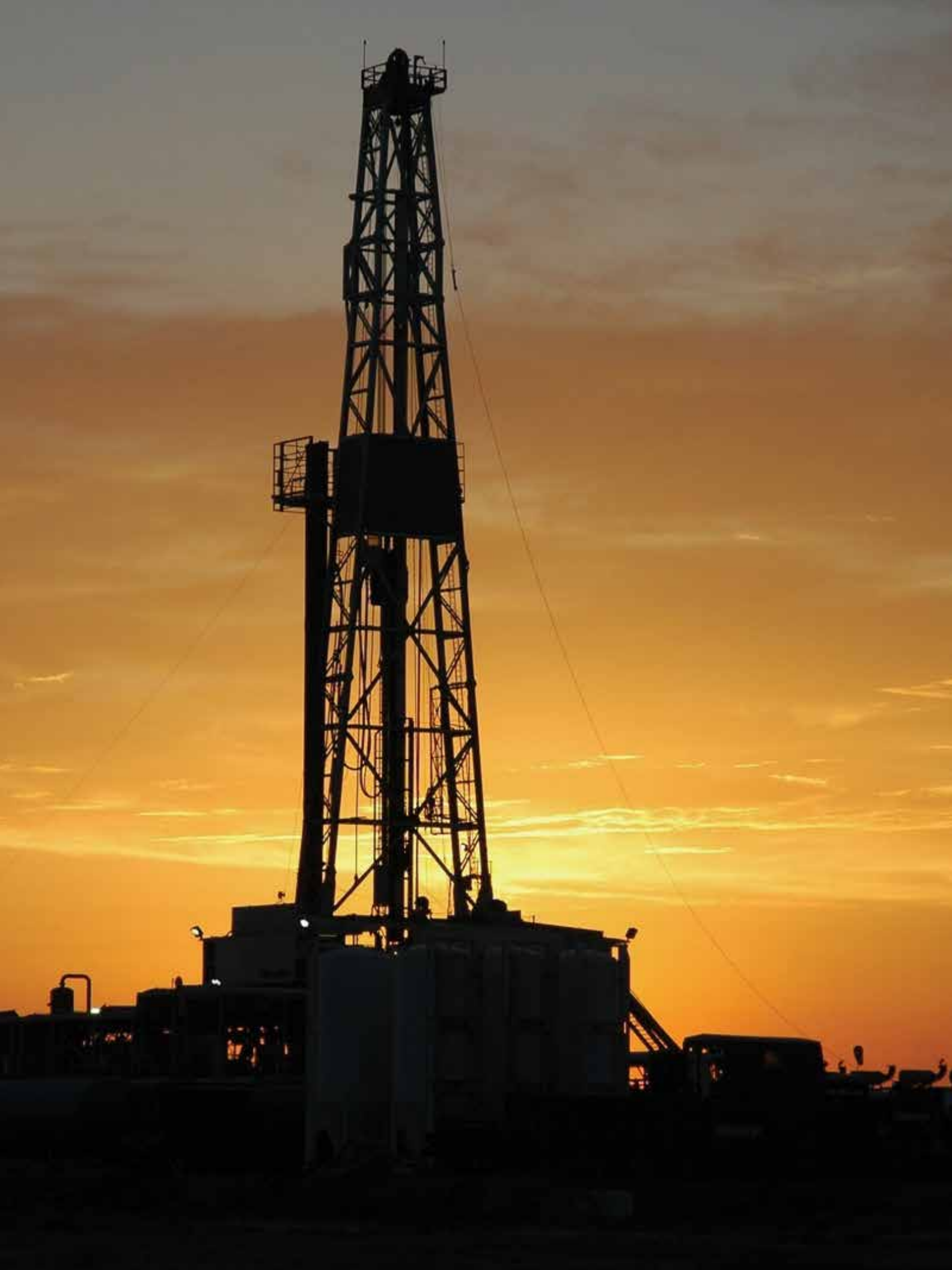

The next generation of drive technology

Cutting-edge power electronics technology and decades of process expertise come together in the MV7000 — a world-class water-cooled medium voltage drive suitable for a wide range of power conversion applications. Easy to install and maintain, the drive offers high reliability and availability and helps increase the uptime of critical processes. The MV7000 provides a flexible approach to achieve a customized solution across different applications.

With the MV7000 our power conversion expertise helps increase operating efficiency, power availability, plant throughput, operational precision, and process yield. We are helping our customers meet the demands and opportunities of the new electric age.

Benefits:

- **Peak power density** — our drive can deliver up to 15 MW with just 18 IGBTs, which is equivalent to a power density of 1.5 MVA/m³
- **High reliability and availability** — over 10 million hours in operation across an installed base of over 8.5 GW
- **Power scalability with à la carte option packaging** that can be adapted to a wide range of applications
- **A full family of drives** — GE is your one-stop provider with a wide portfolio of drives

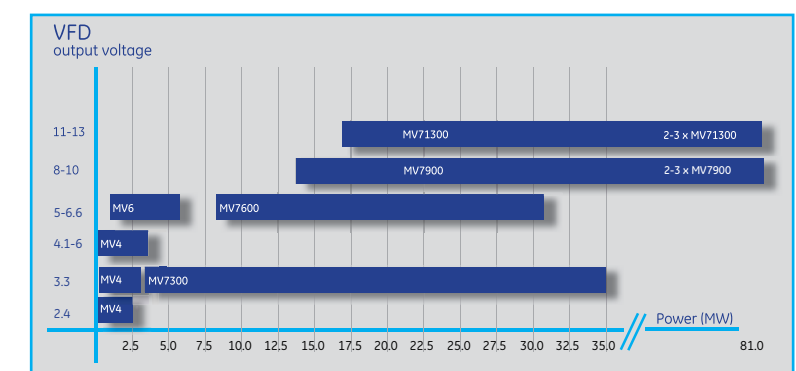

The MV7000 belongs to GE's wide range of drives for all applications.

Advantages of a medium voltage variable frequency system

Reliability & availability

The higher reliability and lower maintenance needs of a variable speed drive system compared to gearboxes and hydraulic couplings result in lower lifecycle cost.

Saving energy, caring for the environment

In today's world more than ever, energy saved is energy produced. For a variety of loads, from water pumps to gas compressors, variable speed control offers the best way to capture energy savings.

Precise power delivery

In many applications, the superiority of electrical control simply cannot be matched by mechanical systems. Precise control of power means better outcomes, from the flatness of a steel sheet to the accuracy of offshore Oil & Gas exploration.

Variable frequency drives can be used in a variety of industries and applications

Industry sector	Applications
Oil and gas	eLNG trains, injection compressors and pumps, gas storage, multiphase pumps, pipeline compressors
Marine	Cruise ships, LNG carriers, offshore drilling vessels, research vessels, megayachts, merchant vessels, navy support vessels
General and heavy industry	Metal rolling mills, test benches, grinders, water pumps, mine winders, crushers, ID fans, FD fans, wind turbines, static frequency converters, boiler feed pump, power quality systems

MV7000 – Enhanced technology

Key benefits

- Peak power density
- High reliability and availability
- Power scalability with customizable options featuring:
 - Low harmonics without additional equipment
 - Four quadrant operation for regenerative applications
 - Transformerless design for compactness
 - Common DC bus system for energy savings
 - High performance process control
 - Visor Connect supports warranty with remote real-time support and advice
- Front access maintenance
- Simplified cooling system architecture and gate drive power supply topology
- Fuseless design



Power stack



Inverter cubicle

Best-in-class power density

The phase power stack is the main modular building block of the three-level inverter.

- Compact enclosures thanks to double sided cooling of the IGBTs
- Just 18 IGBTs at 3.3 kV can deliver 15 MW
- Control hardware mounted on a slide in/out frame

High reliability and availability

The MV7000 is a great example of a design philosophy based on minimizing component count while retaining peak performance. Press-pack IGBT (PPI) power devices enable:

- The capability to limit overcurrent with safe turn-off under all operating and failure conditions
- Case rupture-free due to pressed contacts and no-wire bonding
- N+1 series redundancy thanks to the capability of PPI for continuous conduction under failure mode
- Long life expectancy even under load cycling
- Effective performance even at low motor frequency operation

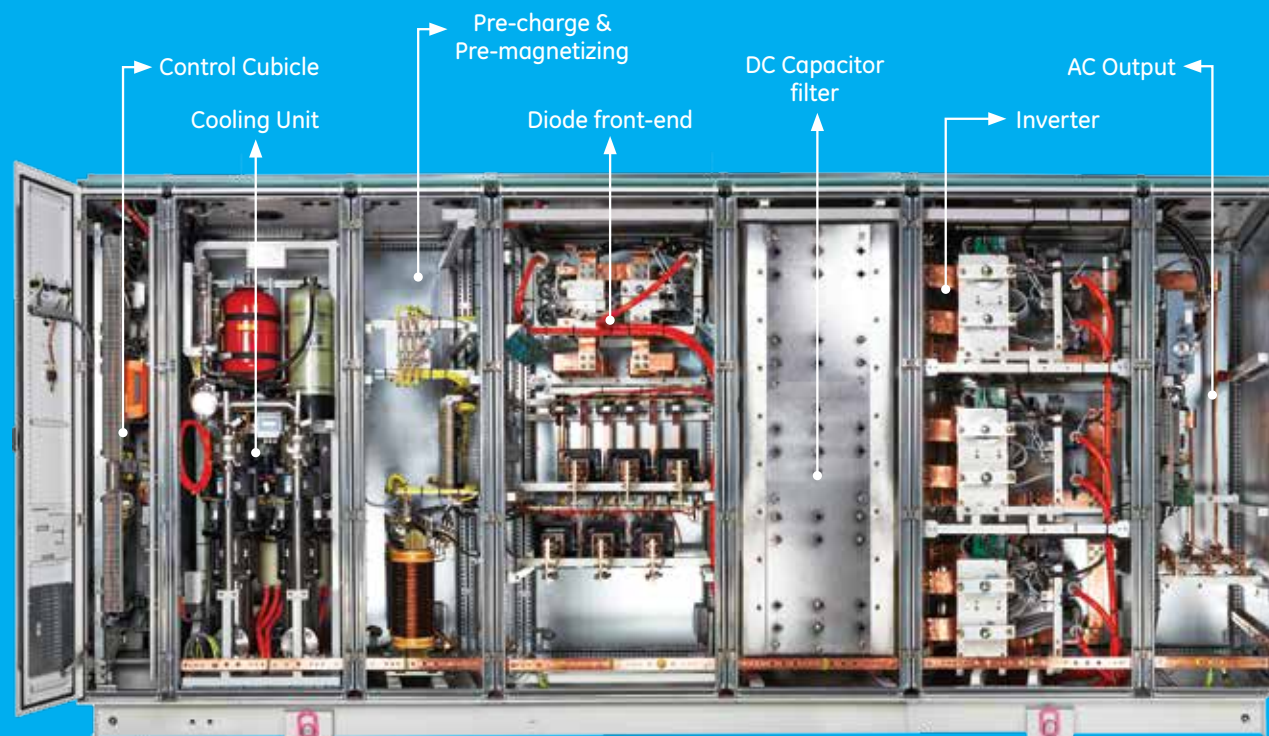

Inside look at the MV7000

Power scalability with customizable options

MV7000 comes in a standard Diode-Front-End (DFE) rectifier configuration.

Low harmonics without additional equipment

- Available in 12, 24 and 36-pulse configurations
- Low levels on harmonics – IEEE 519 compliant
- No additional filters necessary
- Fully able to handle faults such as voltage dips
- For reversing applications, an active-front-end (AFE) is available

Four quadrant operation for energy savings

- Regeneration of the energy to the network through IGBT bridge
- Unity power factor
- Sinusoidal input with negligible harmonics

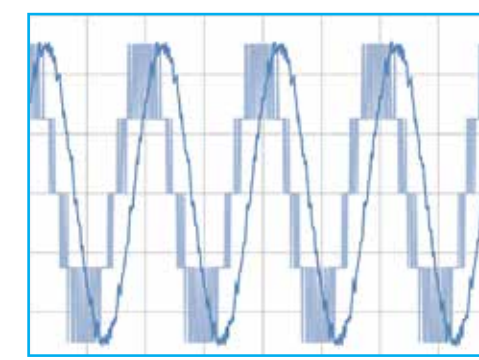
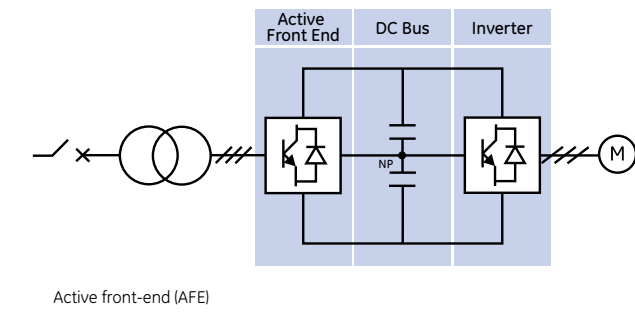
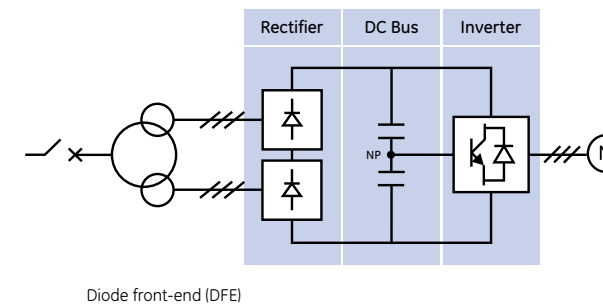

Transformerless design for compactness

The MV7000 is available in transformerless design

- AFE with additional input filter to reduce line harmonics
- Big savings in capital cost, installation cost and footprint
- Increased overall system efficiency and reliability

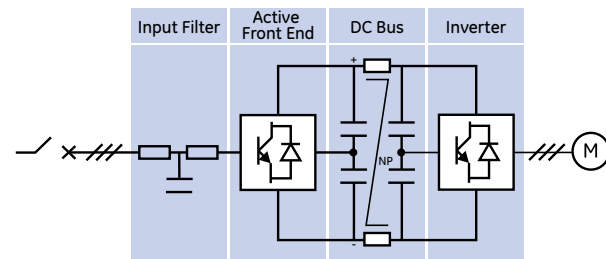

Transformerless design

Common DC bus system for energy savings

For multi-drive applications, a common DC link system is available

- Shared Active-Front-End (AFE) rectifier configuration

- Saves energy by the redistribution of power from braking
- Reduction in overall equipment cost, operating cost and footprint

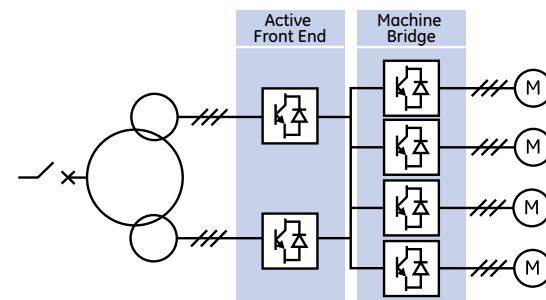

Common DC bus system

High performance process control

MV7000 is equipped with a standard Power Electronics Controller (PECe)

- Mounted on slide in/out frame for easy access and compactness
- Advanced Vector Control (AVC)
- Fast dynamic response
- Clean, robust power delivery
- Fully customizable

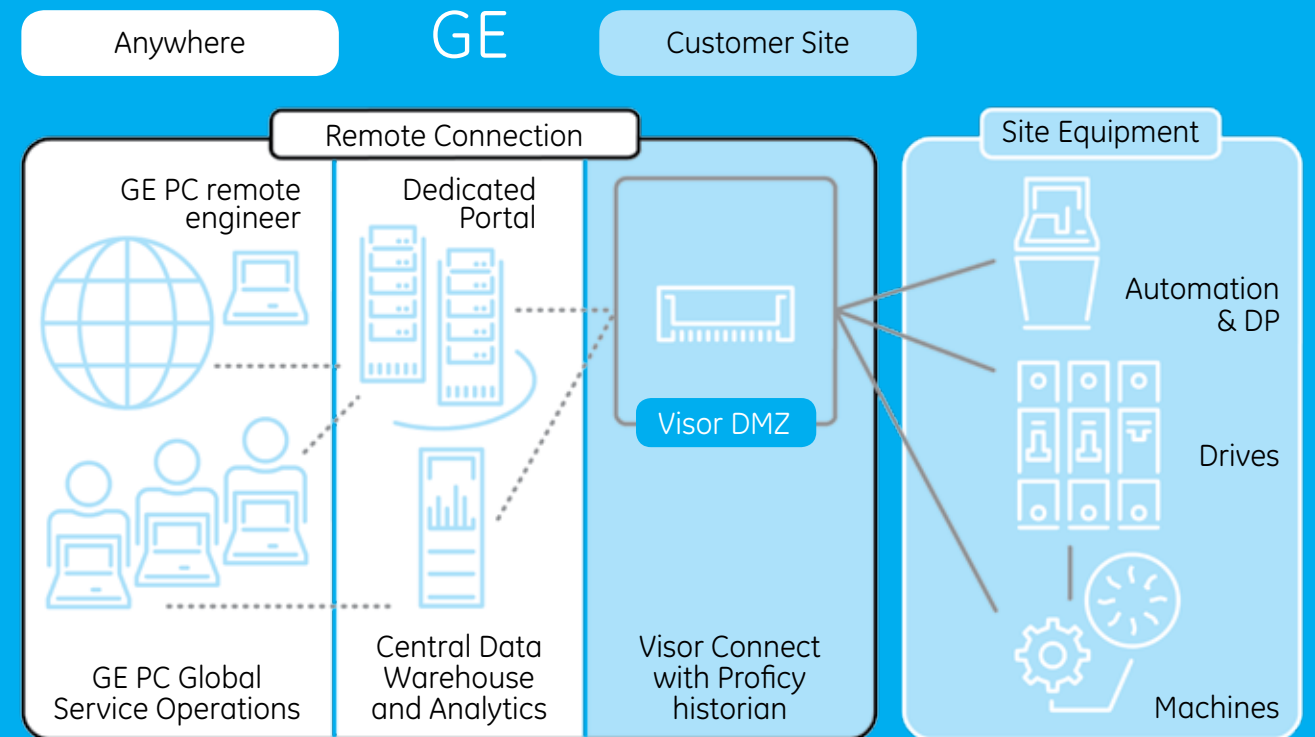

Visor Connect: Remote connection to equipment, monitoring and support

Visor Connect provides secured remote connection to GE equipment (outside the control network). Remote connection enables GE's service engineers to provide real-time support, ongoing health analytics and key performance indicators (KPIs), as well as basic configuration management support.

Key benefits

- Reduce unscheduled downtime
- Real-time support and advice
- Customers can access GE's global Services organization 24/7, 365 days a year from anywhere in the world

Process control benefits

Incoming power dip ride-through

The MV7000 provides incoming power loss ride-through and keeps the process running without tripping.

Under-voltage operation

The MV7000 operates continuously and provides power to the motor at a lower input supply voltage (down to 70% of nominal voltage).

Flying start into a spinning load

The MV7000 offers the ability to catch and take control of a spinning load without any damaging torque, voltage or current impacting the equipment if started while the load is already spinning.

Critical speed avoidance

The MV7000 can be programmed for up to three critical frequency bands and ride-through these without any resonance issues.

Independent acceleration and deceleration ramps

The MV7000 can be programmed into the drive controls as needed for controlled starting and stopping of the load.



High performance control

MV7000 — À la carte option packaging

Feature suite for every application

Standard product customizable with pre-engineered options including, but not limited to:

- Redundant pump for cooling
- Customizable process control
- DB chopper
- Communication protocols
- Harsh environment packaging
- Vibration and shock reinforcement
- Marine-class package
- Up and down synchronous transfer

Motor friendly

- Suited for synchronous induction and permanent magnet motors
- Output waveforms reduce motor losses
- Reduced motor noise and vibration
- No significant motor shaft torque pulsations
- Wide speed range with a consistent response

MV7000 ratings

Output voltage	VFD frame size	Rectifier type	Power output		Output current
			MW	MVA	A
3.3kV	MV7303	DFE 12p	3.8	4.3	750
	MV7303	AFE	3.8	4.3	750
	MV7306	DFE 12p	6.9	7.7	1350
	MV7306	AFE	6.9	7.7	1350
	MV7310	DFE 12p	10.8	12	2100
	MV7310	AFE	8.8	9.8	1550
	MV7312	DFE 24p	13.3	14.8	2600
	MV7312	AFE	13.3	14.8	2320
	MV7315	DFE 24p	15	17	2900
	MV7315	AFE	13.3	17	2320
	2xMV7310	2xDFE 12p	21.6	24	4200
	2xMV7310	AFE	17.6	19.6	3100
	2xMV7312	2xDFE 24p	26.6	29.6	5200
	2xMV7312	AFE	26.6	29.6	4640
2xMV7315	2xDFE 24p	30	34	5800	
2xMV7315	AFE	26.6	34	4640	
5.2kV	MV7607	DFE 24p	7	8.6	950
	MV7615	DFE 24p	14	16.2	1800
6.6kV	MV7609	DFE 24p	10	12.6	1100
	MV7609	AFE	8	10	800
	MV7616	DFE 24p	15.4	17	1500
	MV7618	DFE 24p	18	22.8	2000
8.2kV	MV7618	AFE	14.3	17.9	1250
	MV7821	DFE 36p	21	21.3	1500
10kV	MV7913	DFE 36p	13	17.1	1000
	MV7927	DFE 36p	27	33.7	2000
	MV7927	AFE	21.4	26.7	1250
	2xMV7927	2xDFE 36p	54	67.4	4000
	3xMV7927	3xDFE 36p	81	101	6000

Table shows the typical ratings for variable torque load applications. Please contact GE sales for constant torque applications.

Dimensions & weights

Output voltage	VFD frame size	Width	Depth	Weight
		inches/mm	inches/mm	lbs./kg
3.3kV	MV7303	157 / 4000	39 / 1000	8818 / 4000
	MV7303	189 / 4800	39 / 1000	10582 / 4800
	MV7306	173 / 4400	39 / 1000	9700 / 4400
	MV7306	205 / 5200	39 / 1000	11464 / 5200
	MV7310	173 / 4400	39 / 1000	9700 / 4400
	MV7310	220 / 5600	39 / 1000	12346 / 5600
	MV7312	189 / 4800	39 / 1000	10582 / 4800
	MV7312	252 / 6400	39 / 1000	14109 / 6400
	MV7315	197 / 5000	39 / 1000	11023 / 5000
	MV7315	260 / 6600	39 / 1000	14550 / 6600
	2xMV7310	425 / 10800	39 / 1000	23810 / 10800
	2xMV7310	441 / 11200	39 / 1000	24692 / 11200
	2xMV7312	457 / 11600	39 / 1000	25574 / 11600
	2xMV7312	582 / 14800	39 / 1000	32627 / 14800
2xMV7315	472 / 12000	39 / 1000	26455 / 12000	
2xMV7315	520 / 15200	39 / 1000	33508 / 15200	
5.2kV	MV7607	291 / 7400	55 / 1400	16314 / 7400
	MV7615	299 / 7600	55 / 1400	16754 / 7600
	MV7609	291 / 7400	55 / 1400	16314 / 7400
6.6kV	MV7609	409 / 10400	55 / 1400	22928 / 10400
	MV7616	299 / 7600	47 / 1200	16754 / 7600
	MV7618	299 / 7600	55 / 1400	16754 / 7600
	MV7618	425 / 10600	55 / 1400	23368 / 10600
8.2kV	MV7821	402 / 10200	55 / 1400	22487 / 10200
	MV7913	386 / 9800	55 / 1400	21605 / 9800
10kV	MV7927	402 / 10200	55 / 1400	22486 / 10200
	MV7927	567 / 14400	55 / 1400	31745 / 14400
	2xMV7927	803 / 20400	55 / 1400	44972 / 20400
	3xMV7927	1205 / 30600	55 / 1400	67458 / 30600

MV7000 drive specifications

VFD ratings	
Output power	3 – 81 MW
Output voltage	up to 10 kV
Output frequency	15-90 Hz, 0 to 15 Hz on request
Input voltage	3 to 10 kV ±10%
Input frequency	50 or 60 Hz ±5%
Auxiliary voltage	3 phase, 400 V, 440 V, 480 V, or 600 V; 50/60 Hz 1 phase, 110 V, 230 V, 50/60 Hz
Power quality	
Line side converter	DFE 12 to 36-pulse / AFE IGBT 6-pulse
Load side inverter	3-level VSI; IGBTs
VFD system efficiency	Up to 99%
Power factor	>0.96 (DFE) / 1 (AFE)
Input harmonics	IEEE 519 compliant
Energy storage	
DC link	Self-healing, long life, film capacitors
VFD control	
Mode of operation	Four-quadrant
Mode of control	Flux vector / without encoder / induction motor & synchronous (option)
Analog input / output	(3) inputs / (3) outputs +/-10 Vdc or 4-20 mA standard
Digital input / output	(6) inputs / (6) outputs standard
Speed regulation	<0.5% without encoder and <0.1% with encoder
LAN interface	Ethernet modbus standard optional: profibus; devicenet
Protective functions	Over-current, current limit, over and under-voltage, motor stall
Environment & enclosure	
Enclosure	IP31, IP33, IP44, others on request
Ambient / elevation	0-45°C / 1000m above sea level; higher with de-rating
Insulation coordination	Pollution degree 2 per EN 61800-5-1 and EN 50178
Industry standards	
Standards	IEC 61800-3, IEC 61800-4, IEC 61800-5 Qualification to industry-specific standards available Marine classification society/compliant

Services from GE – a focus on availability

We understand the vital importance of process availability – and our focus on service keeps us actively engaged, both when things are going right, and when they are going wrong.

Our world-class Global Customer Service and Support Center is available 24/7, 365 days a year. Our strategic distribution centers and authorized distributors carry an extensive inventory of GE's drives, allowing us to quickly fulfill your genuine replacement part needs, no matter where you are located.

With a comprehensive global network of service engineers and technicians, GE is uniquely positioned to provide the knowledge, experience and skills for your full range of industrial service requirements. From system design to maintenance and outage support, we have the resources and capabilities to advance your equipment's performance and reliability. Some key benefits of GE's support are:

- Single point of contact
- Reduced call-out rates
- 24/7 availability
- Rapid mobilization of engineers
- Routine maintenance visits
- Training
- System health checks
- Spares management
- Obsolescence management

GE also provides managed system upgrade paths for our legacy systems and has significant experience in replacing systems from other manufacturers with low disruption to the existing infrastructure.

Remote support

Visor Connect, GE's remote diagnostic and support system, is based on highly secure satellite communications links. It enables our experts, regardless of their geographical location, to look over the shoulder of your onsite equipment operator or technician and advise and assist you on fault finding and resolution.

MAIN OFFICES

Australia, Botany
Tel: +61 (0) 2 8313 9980

Brazil, Minas Gerais
Tel: +55 31 3330 5800

Canada, Mississauga
Tel: +1 905 858 5100

Chile, Santiago
Tel: +56 2 652 6500

China, Shanghai
Tel: +86 21 6198 2600

France, Massy Cedex
Tel: +33 1 77 31 20 00

Germany, Berlin
Tel: +49 30 7622 0

India, Chennai
Tel: +91 44 4968 0000

Japan, Tokyo
Tel: +81 3 5544 3852

Norway, Oslo
Tel: +47 67 83 82 50

Russia, Moscow
Tel: +7 495 981 13 13

Singapore
Tel: +65 6332 0940

South Africa, Midrand
Tel: +2711237 0000

South Korea, Busan
Tel: +82 51 710 9015

UAE, Dubai
Tel: +971 44296161

UK, Rugby
Tel: +44 1788 563 563

USA, Pittsburgh
Tel: +1 412 967 0765



imagination at work

www.gepowerconversion.com

Copyright © 2013 General Electric Company and/or its affiliates.
All rights reserved. GEA30737A (12/2014)