

XCR15

3rd Generation Intel® Core™ i7 Based Rugged CPCI Single Board Computer

Features

- Single slot 6U CPCI universal System/Peripheral board
- Support for Hot Swap
- 3rd Generation Intel Core i7 dual and quad core processors
- Integrated two channels up to 16 GB soldered DDR3 SDRAM with ECC
- Up to 6 MB shared cache
- Up to 8 GB Solid State Disk Drive
- Dual on-board Expansion Sites: two PCI-X PMC and one x4, one x8 PCIe XMC
- Front I/O:
 - 2x Gigabit Ethernet ports
 - 1x VGA
 - 1x USB
 - 1x COM port
 - 1 x eSATA (optional)
 - 1 x USB 3.0 (optional)
- Rear I/O:
 - 2x Gigabit Ethernet ports (PICMG 2.16)
 - 1x VGA (2 ports possible if front IO not required)
 - 2x DVI
 - Up to 4x SATA ports
 - 2x COM ports
 - 4x USB ports (1 upgradable to USB3.0 in place of 1 SATA port)
 - 1x Audio
 - 13x GPIO
 - 2x PMC rear I/O
 - 2X XMC rear I/O

- BIOS backup Flash
- Optional on-board SATA HDD
- Optional conduction cooling
- Optional extended operating temperature range
- Deployed Test Software
- Windows®, Linux® and Real-Time OS support

The XCR15 Rugged Single Board Computer (SBC) from GE Intelligent Platforms features the high performance, highly integrated 3rd Generation Core i7 processor platform from Intel.

3rd Generation Core i7 offers integrated graphics and memory controller plus dual and quad core processing up to 2.5 GHz all in one device. Coupled with the Mobile Intel QM77 Express Chipset this provides an unmatched level of I/O bandwidth for both on-board and off-board functions.

Features of the 3rd Gen. Core i7 processor

- Up to 15% (compute) and 50% (3D graphics) performance improvement over previous generation
- Advanced Vector Extensions (AVX) signal processing
- Intelligent performance on-demand with Intel Turbo Boost Technology
- PCIe GEN 3 (8 GT/sec) and USB 3.0 (10x the Bandwidth of 2.0) data transfer capability
- Hyper-Thread Technology – 2 threads per core

In addition to a comprehensive range of onboard I/O features, the XCR15 also offers two on-board mezzanine expansion sites for enhanced system flexibility, both of which offer PMC and XMC capability. Memory resources include up to 16 GB DDR3 SDRAM, 8 GB Solid State Disk Drive, optional SATA hard drive, BIOS Flash and BIOS backup Flash.

The XCR15 is designed to meet the requirements of a wide range of applications from industrial through to fully rugged Defense and Aerospace programs. It offers extended temperature capability and a range of air and conduction cooled build levels.

A rich software choice is planned for the XCR15, including comprehensive Deployed Test Software (BIT and BCS) plus OS support for Windows 7, Open Linux, Wind River Linux, VxWorks®.

Specifications

Processor

- Intel 3rd Gen. Core i7 Processor, options include but are not limited to:
 - i7-3615QE (Quad Core) @ 2.3 GHz (45W)
 - i7-3555LE (Dual Core) @ 2.5 GHz (25W)
 - i7-3517UE (Dual Core) @ 1.7 GHz (17W)(Actual speed/power is dependent on environment)
- 22nm monolithic die processing technology
- Last Level Cache
 - 6 MB (Quad i7)
 - 4 MB (Dual i7)

SDRAM

- Maximum memory configuration of dual channels up to 16 GB DDR3 SDRAM soldered with ECC

Flash Memory

- Soldered Solid State Disk Drive up to 8 GB

BIOS

- 1x 16 Mb for BIT and BIOS plus 1x 16 Mb for redundancy

Ethernet

- Dual Gigabit Ethernet interface via two Intel 82574 Gigabit Ethernet controllers – routed to front panel
- Dual Gigabit Ethernet interface via two Intel 82574 Gigabit Ethernet controllers – routed to rear (PICMG® 2.16 compliant)



XCR15 Intel 3rd Generation Core i7 Based Rugged CPC Single Board Computer

Specifications (continued)

USB Ports

- Four USB 2.0 ports routed to rear J4 connector (one of which is upgradable to USB3.0 in place of 1 SATA port)
- One USB 2.0 port routed to front panel
- One USB 3.0 port (optional) routed to front panel (precludes use of XMC / PMC site 2)

CompactPCI Backplane Interface

- PICMG 2.0 R3.0 compliant CPC local bus standard

Serial Ports

- Three 16550 compatible full duplex async serial ports
- One routed to front panel RS-232 (COM3)
- Two routed to J5, with user selectable RS-232/422/485
- Ports feature independent 16-byte FIFO supporting baud rates up to 115 Kbaud

PMC/XMC Expansion

- Up to two on-board mezzanine expansion sites
 - Site 1 PMC (PCI-X up to 64-bit /133 MHz) and XMC (x8 PCIe Gen 3) capable; XMC and PMC rear routed to J3
 - Site 2 PMC (PCI-X up to 64-bit /133 MHz) and XMC (x4 PCIe Gen 2) capable; PMC rear IO routed to J5
- PCI signaling is 3.3V, 5V tolerant; +/- 12V mezzanine only
- 25W per site capable mezzanine power supply

Audio

- High Definition Audio Codec
- Stereo line in and stereo line out

Video

- One VGA port routed to front panel
- One VGA port routed to J4; can be two ports if front I/O not used
- Two DVI ports routed to rear I/O J4/J5

SATA

- Four SATA ports to rear I/O
- One eSATA port (optional) routed to front panel (precludes use of XMC / PMC site 2)

GPIO

- 13 GPIO pins – software configurable

On-board Hard Drive

- SATA hard drive or SSD can be optionally ordered (precludes use of PMC/XMC site 2)

LED (not in conduction-cooled style)

- Three status LEDs and four BIT status on front panel
- Two status LEDs on rear

MRAM / Watchdog/ Real-Time Clock/ TPM

- 512 kB non-volatile RAM (MRAM)
- SuperIO watchdog
- Real-time clock in Cougar Point PCH

Power Requirements

- +5, +3.3V
- +12V for mezzanine only

Block Diagram

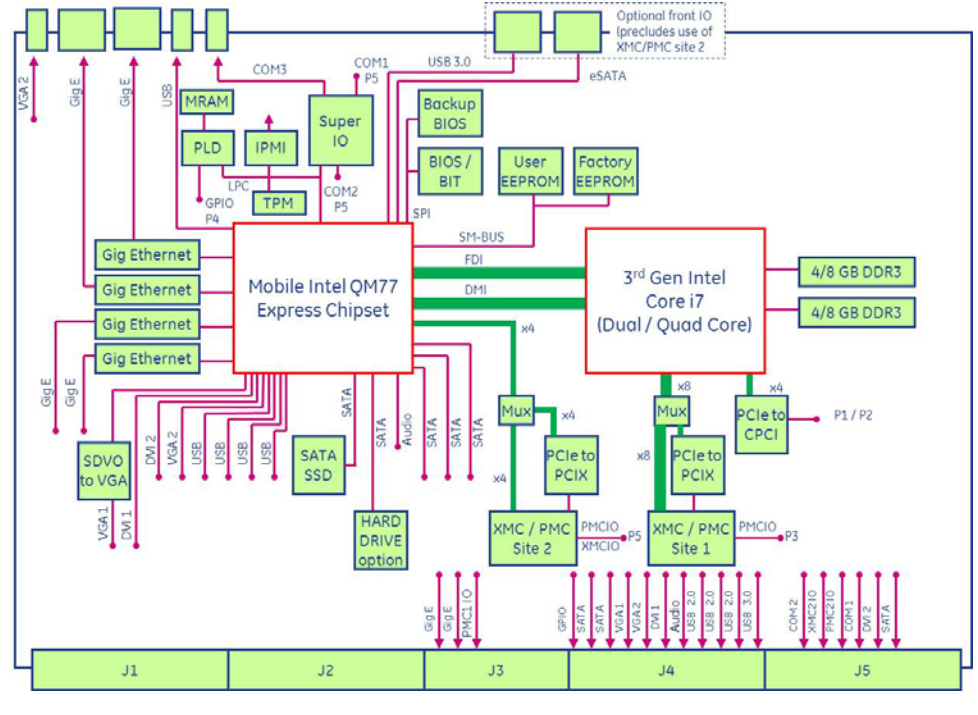

Temperature Sensor

- Onboard ambient temperature; CPU

Other HW Features

- Hardware Write Protection
- Front power button LED
- IPMI 2.0 Controller (PICMG 2.9)

Transition Module

- CTM20

Certification

- CE

Environmental

| | Level 1 | Level 2 | Level 3 | Level 4 | Level 5 |
|-------------------|--------------------------|--------------------------|--------------------------|-------------------------|-------------------------|
| Cooling Method | Convection | Convection | Convection | Conduction | Conduction |
| Conformal Coating | Optional | Standard | Standard | Standard | Standard |
| High/Low Temp | 0 to +55° C | -20 to +65° C | -40 to +75° C | -40 to +75° C | -40 to +85° C |
| Operational | (300 ft/m) | (300 ft/m) | (600 ft/m) | At cold wall | At cold wall |
| Random Vibration | 0.002g ² /Hz* | 0.002g ² /Hz* | 0.04g ² /Hz** | 0.1g ² /Hz** | 0.1g ² /Hz** |
| Shock | 20g*** | 20g*** | 20g*** | 40g*** | 40g*** |

*With a flat response to 1000 Hz, 6 dB/Oct roll-off from 1000 to 2000 Hz ** From 10 to 1000 Hz *** Peak sawtooth 11 ms duration

Note : Processor performance and temperature are inter-dependent. For a given temperature, a maximum speed is achievable, and conversely for a given processor speed a maximum temperature is achievable. Consult the product manual for details

About GE Intelligent Platforms

GE Intelligent Platforms, a General Electric Company (NYSE: GE), is an experienced high-performance technology company and a global provider of hardware, software, services, and expertise in automation and embedded computing. We offer a unique foundation of agile, advanced and ultra-reliable technology that provides customers a sustainable advantage in the industries they serve, including energy, water, consumer packaged goods, government and defense, and telecommunications. GE Intelligent Platforms is a worldwide company headquartered in Charlottesville, VA and is part of GE Home and Business Solutions. For more information, visit www.ge-ip.com.

GE Intelligent Platforms Contact Information

Americas: 1 800 433 2682 or 1 434 978 5100

Global regional phone numbers are listed by location on our web site at defense.ge-ip.com/contact

defense.ge-ip.com

©2012 GE Intelligent Platforms. All Rights Reserved.
All other brands or names are property of their respective holders.
Specifications are subject to change without notice.

