

Cinterion® PLS62-W

Hardware Interface Overview

Version: 00.080
DocId: PLS62-W_hio_v00.080

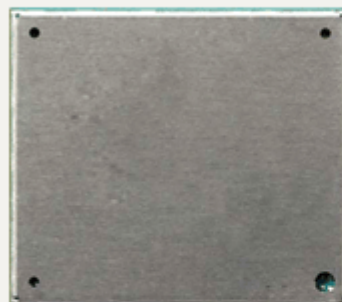

Document Name: **Cinterion® PLS62-W Hardware Interface Overview**

Version: **00.080**

Date: **2017-10-12**

DocId: **PLS62-W_hio_v00.080**

Status **Confidential / Preliminary**

GENERAL NOTE

THE USE OF THE PRODUCT INCLUDING THE SOFTWARE AND DOCUMENTATION (THE "PRODUCT") IS SUBJECT TO THE RELEASE NOTE PROVIDED TOGETHER WITH PRODUCT. IN ANY EVENT THE PROVISIONS OF THE RELEASE NOTE SHALL PREVAIL. THIS DOCUMENT CONTAINS INFORMATION ON GEMALTO M2M PRODUCTS. THE SPECIFICATIONS IN THIS DOCUMENT ARE SUBJECT TO CHANGE AT GEMALTO M2M'S DISCRETION. GEMALTO M2M GMBH GRANTS A NON-EXCLUSIVE RIGHT TO USE THE PRODUCT. THE RECIPIENT SHALL NOT TRANSFER, COPY, MODIFY, TRANSLATE, REVERSE ENGINEER, CREATE DERIVATIVE WORKS; DISASSEMBLE OR DECOMPILE THE PRODUCT OR OTHERWISE USE THE PRODUCT EXCEPT AS SPECIFICALLY AUTHORIZED. THE PRODUCT AND THIS DOCUMENT ARE PROVIDED ON AN "AS IS" BASIS ONLY AND MAY CONTAIN DEFICIENCIES OR INADEQUACIES. TO THE MAXIMUM EXTENT PERMITTED BY APPLICABLE LAW, GEMALTO M2M GMBH DISCLAIMS ALL WARRANTIES AND LIABILITIES. THE RECIPIENT UNDERTAKES FOR AN UNLIMITED PERIOD OF TIME TO OBSERVE SECRECY REGARDING ANY INFORMATION AND DATA PROVIDED TO HIM IN THE CONTEXT OF THE DELIVERY OF THE PRODUCT. THIS GENERAL NOTE SHALL BE GOVERNED AND CONSTRUED ACCORDING TO GERMAN LAW.

Copyright

Transmittal, reproduction, dissemination and/or editing of this document as well as utilization of its contents and communication thereof to others without express authorization are prohibited. Offenders will be held liable for payment of damages. All rights created by patent grant or registration of a utility model or design patent are reserved.

Copyright © 2017, Gemalto M2M GmbH, a Gemalto Company

Trademark Notice

Gemalto, the Gemalto logo, are trademarks and service marks of Gemalto and are registered in certain countries. Microsoft and Windows are either registered trademarks or trademarks of Microsoft Corporation in the United States and/or other countries. All other registered trademarks or trademarks mentioned in this document are property of their respective owners.

Contents

1	Introduction	7
1.1	Key Features at a Glance	7
1.2	PLS62-W System Overview.....	11
2	Interface Characteristics	12
2.1	Application Interface	12
2.1.1	USB Interface.....	12
2.1.2	Serial Interface ASC0	13
2.1.3	Serial Interface ASC1	14
2.1.4	UICC/SIM/USIM Interface.....	15
2.1.4.1	SIM Card Interface Switch	16
2.1.5	GPIO Interface	17
2.1.6	I ² C Interface	18
2.1.7	SPI Interface	18
2.1.8	PWM Interfaces	18
2.1.9	Pulse Counter	18
2.1.10	Status LED.....	18
2.1.10.1	Fast Shutdown	19
2.1.11	700MHz Antenna Switch Control	19
2.1.12	TX Activity Signal	19
2.2	RF Antenna Interface.....	20
2.2.1	Antenna Installation	21
2.2.2	RF Line Routing Design.....	21
2.2.2.1	Line Arrangement Examples	21
2.2.2.2	Routing Example.....	26
2.3	Sample Application	27
3	Operating Characteristics	29
3.1	Operating Modes	29
3.2	Power Supply.....	30
4	Mechanical Dimensions, Mounting and Packaging.....	31
4.1	Mechanical Dimensions of PLS62-W.....	31
5	Regulatory and Type Approval Information	33
5.1	Directives and Standards.....	33
5.2	SAR requirements specific to portable mobiles	36
5.3	Reference Equipment for Type Approval.....	37
5.4	Compliance with FCC Rules and Regulations	38
6	Document Information.....	40
6.1	Revision History	40
6.2	Related Documents	40
6.3	Terms and Abbreviations	40
6.4	Safety Precaution Notes	43

7	Appendix.....	44
7.1	List of Parts and Accessories.....	44

Tables

Table 1:	Signals of the SIM interface (SMT application interface)	15
Table 2:	GPIO lines and possible alternative assignment.....	17
Table 3:	Return loss in the active band.....	20
Table 4:	Directives	33
Table 5:	Standards of North American type approval	33
Table 6:	Standards of European type approval.....	33
Table 7:	Requirements of quality	34
Table 8:	Standards of the Ministry of Information Industry of the People's Republic of China	34
Table 9:	Toxic or hazardous substances or elements with defined concentration limits	35
Table 10:	Antenna gain limits for FCC and IC (TBD.).....	38
Table 11:	List of parts and accessories.....	44
Table 12:	Molex sales contacts (subject to change)	45

Figures

Figure 1:	PLS62-W system overview	11
Figure 2:	USB circuit	12
Figure 3:	Serial interface ASC0.....	13
Figure 4:	Serial interface ASC1.....	14
Figure 5:	UICC/SIM/USIM interfaces	16
Figure 6:	Embedded Stripline with 65 μ m prepreg (1080) and 710 μ m core	21
Figure 7:	Micro-Stripline on 1.0mm standard FR4 2-layer PCB - example 1	22
Figure 8:	Micro-Stripline on 1.0mm Standard FR4 PCB - example 2.....	23
Figure 9:	Micro-Stripline on 1.5mm Standard FR4 PCB - example 1.....	24
Figure 10:	Micro-Stripline on 1.5mm Standard FR4 PCB - example 2.....	25
Figure 11:	Routing to application's RF connector	26
Figure 12:	PLS62-W evaluation board layer table.....	26
Figure 13:	Schematic diagram of PLS62-W sample application	28
Figure 14:	PLS62-W– top and bottom view.....	31
Figure 15:	Dimensions of PLS62-W (all dimensions in mm).....	32
Figure 16:	Reference equipment for Type Approval	37

1 Introduction

This document¹ describes the hardware of the Cinterion® PLS62-W module. It helps you quickly retrieve interface specifications, electrical and mechanical details and information on the requirements to be considered for integrating further components.

1.1 Key Features at a Glance

Feature	Implementation
<i>General</i>	
Frequency bands	GSM/GPRS/EDGE: Quad band, 850/900/1800/1900 MHz UMTS/HSPA+: Seven band, 800 (BdXIX) / 850 (BdV) / 900 (BdVIII) / AWS (BdIV) / 1800 (BdIX) / 1900 (BdII) / 2100MHz (BdI) LTE: Twelve band, 700 (Bd12 <MFBI Bd17>, Bd28) 800 (Bd18, Bd19, Bd20) 850 (Bd5) / 900 (Bd8) / AWS (Bd4) / 1800 (Bd3) / 1900 (Bd2) / 2100 (Bd1) / 2600 (Bd7)
GSM class	Small MS
Output power (according to release 99)	Class 4 (+33dBm ±2dB) for EGSM850 Class 4 (+33dBm ±2dB) for EGSM900 Class 1 (+30dBm ±2dB) for GSM1800 Class 1 (+30dBm ±2dB) for GSM1900 Class E2 (+27dBm ± 3dB) for GSM 850 8-PSK Class E2 (+26dBm ± 3dB) for GSM 900 8-PSK Class E2 (+26dBm +3 /-4dB) for GSM 1800 8-PSK Class E2 (+26dBm +3 /-4dB) for GSM 1900 8-PSK
Output power (according to Release 99)	Class 3 (+24dBm +1/-3dB) for UMTS 800, WCDMA FDD BdXIX Class 3 (+24dBm +1/-3dB) for UMTS 850, WCDMA FDD BdV Class 3 (+24dBm +1/-3dB) for UMTS 900, WCDMA FDD BdVIII Class 3 (+24dBm +1/-3dB) for UMTS AWS, WCDMA FDD BdIV Class 3 (+24dBm +1/-3dB) for UMTS 1800, WCDMA FDD BdIX Class 3 (+24dBm +1/-3dB) for UMTS 1900, WCDMA FDD BdII Class 3 (+24dBm +1/-3dB) for UMTS 2100, WCDMA FDD BdI
Output power (according to Release 8)	Class 3 (+23dBm ±2dB) for LTE 700, LTE FDD Bd12 <MFBI Bd17> Class 3 (+23dBm ±2dB) for LTE 700, LTE FDD Bd28 Class 3 (+23dBm ±2dB) for LTE 800, LTE FDD Bd18 Class 3 (+23dBm ±2dB) for LTE 800, LTE FDD Bd19 Class 3 (+23dBm ±2dB) for LTE 800, LTE FDD Bd20 Class 3 (+23dBm ±2dB) for LTE 850, LTE FDD Bd5 Class 3 (+23dBm ±2dB) for LTE 900, LTE FDD Bd8 Class 3 (+23dBm ±2dB) for LTE AWS, LTE FDD Bd4 Class 3 (+23dBm ±2dB) for LTE 1800, LTE FDD Bd3 Class 3 (+23dBm ±2dB) for LTE 1900, LTE FDD Bd2 Class 3 (+23dBm ±2dB) for LTE 2100, LTE FDD Bd1 Class 3 (+23dBm ±2dB) for LTE 2600, LTE FDD Bd7

1. The document is effective only if listed in the appropriate Release Notes as part of the technical documentation delivered with your Gemalto M2M product.

1.1 Key Features at a Glance

Feature	Implementation
Power supply	$3.0V \leq V_{BATT+} \leq 4.5V$
Operating temperature (board temperature)	Normal operation: -30°C to +85°C Extended operation: -40°C to +90°C
Physical	Dimensions: 33mm x 29mm x 3.06mm Weight: approx. 5g
RoHS	All hardware components fully compliant with EU RoHS Directive
<i>LTE features</i>	
3GPP Release 9	UE CAT 1 supported DL 10.2Mbps, UL 5.2Mbps
<i>HSPA features</i>	
3GPP Release 8	DL 7.2Mbps, UL 5.7Mbps HSDPA Cat.8 / HSUPA Cat.6 data rates Compressed mode (CM) supported according to 3GPP TS25.212
<i>UMTS features</i>	
3GPP Release 4	PS data rate – 384 kbps DL / 384 kbps UL CS data rate – 64 kbps DL / 64 kbps UL
<i>GSM/GPRS/EGPRS features</i>	
Data transfer	GPRS: <ul style="list-style-type: none"> • Multislot Class 12 • Full PBCCH support • Mobile Station Class B • Coding Scheme 1 – 4 EGPRS: <ul style="list-style-type: none"> • Multislot Class 12 • EDGE E2 power class for 8 PSK • Downlink coding schemes – CS 1-4, MCS 1-9 • Uplink coding schemes – CS 1-4, MCS 1-9 • SRB loopback and test mode B • 8-bit, 11-bit RACH • PBCCH support • 1 phase/2 phase access procedures • Link adaptation and IR • NACC, extended UL TBF • Mobile Station Class B
SMS	Point-to-point MT and MO Cell broadcast Text and PDU mode Storage: SIM card plus SMS locations in mobile equipment
<i>Software</i>	
AT commands	Hayes 3GPP TS 27.007, TS 27.005, Gemalto M2M AT commands for RIL compatibility

1.1 Key Features at a Glance

Feature	Implementation
Java™ Open Platform	<p>Java™ Open Platform with</p> <ul style="list-style-type: none"> • Java™ profile IMP-NG & CLDC 1.1 HI • Secure data transmission via HTTPS/SSL¹ • Multi-threading programming and multi-application execution <p>Major benefits: seamless integration into Java applications, ease of programming, no need for application microcontroller, extremely cost-efficient hardware and software design – ideal platform for industrial applications.</p> <p>The memory space available for Java programs is 30MB in the flash file system and 18MB RAM. Application code and data share the space in the flash file system and in RAM.</p>
Microsoft™ compatibility	RIL for Pocket PC and Smartphone
SIM Application Toolkit	SAT letter classes b, c, e; with BIP
Firmware update	Generic update from host application over ASC0 or USB modem.
<i>Interfaces</i>	
Module interface	<p>Surface mount device with solderable connection pads (SMT application interface). Land grid array (LGA) technology ensures high solder joint reliability and allows the use of an optional module mounting socket.</p> <p>For more information on how to integrate SMT modules see also [3]. This application note comprises chapters on module mounting and application layout issues as well as on additional SMT application development equipment.</p>
USB	USB 2.0 High Speed (480Mbit/s) device interface, Full Speed (12Mbit/s) compliant
2 serial interfaces	<p>ASC0 (in parts shared with GPIO lines):</p> <ul style="list-style-type: none"> • 8-wire modem interface with status and control lines, unbalanced, asynchronous • Adjustable baud rates: 1,200bps to 921,600bps • Autobauding: 1,200bps to 230,400bps • Supports RTS0/CTS0 hardware flow control. <p>ASC1 (shared with GPIO lines):</p> <ul style="list-style-type: none"> • 4-wire, unbalanced asynchronous interface • Adjustable baud rates: 1,200bps to 921,600bps • Autobauding: 1,200bps to 230,400bps • Supports RTS1/CTS1 hardware flow control
UICC interface	Supported SIM/USIM cards: 3V, 1.8V
GPIO interface	24 GPIO lines comprising: 14 lines shared with ASC0, ASC1 and SPI lines, with network status indication, PWM functionality, fast shutdown, pulse counter, and SIM switch 10 GPIO lines not shared
I ² C interface	Supports I ² C serial interface
SPI interface	Serial peripheral interface, shared with GPIO lines
Antenna switch interface	Control signal for 700MHz antenna switch
TX activity interface	Signal indicating 2G/3G/4G transmit activities
Antenna interface pads	50Ω. UMTS/GSM/LTE main antenna, UMTS/LTE Rx Diversity antenna

1.1 Key Features at a Glance

Feature	Implementation
<i>Power on/off, Reset</i>	
Power on/off	Switch on by hardware signal IGT Switch off by AT command Switch off by emergency off signal (EMERG_OFF) Switch off by hardware signal FST_SHDN instead of AT command Automatic switch off in case of critical temperature or voltage conditions
Reset	Orderly shutdown and reset by AT command
<i>Special features</i>	
Real time clock	Timer functions via AT commands
<i>Evaluation kit</i>	
Evaluation module	PLS62-W module soldered onto a dedicated PCB that can be connected to an adapter in order to be mounted onto the DSB75.
DSB75	DSB75 Development Support Board designed to test and type approve Gemalto M2M modules and provide a sample configuration for application engineering. A special adapter is required to connect the PLS62-W evaluation module to the DSB75.

1. HTTP/SecureConnection over SSL version 3.0 and TLS versions 1.0, 1.1, and 1.2 are supported. For details please refer to Java User's Guide for Cinterion® PLS62-W.

1.2 PLS62-W System Overview

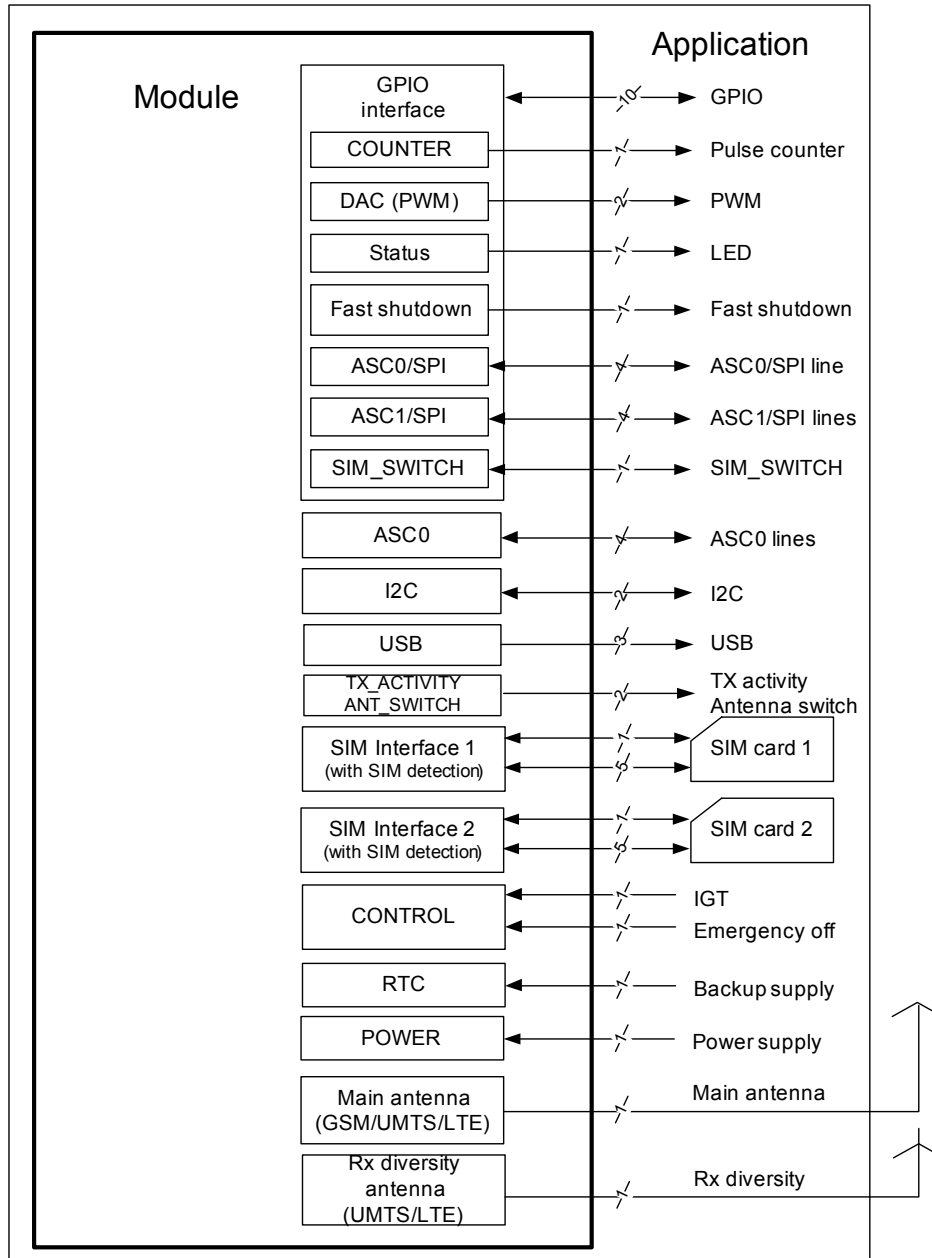

Figure 1: PLS62-W system overview

2 Interface Characteristics

PLS62-W is equipped with an SMT application interface that connects to the external application. The SMT application interface incorporates the various application interfaces as well as the RF antenna interface.

2.1 Application Interface

2.1.1 USB Interface

PLS62-W supports a USB 2.0 High Speed (480Mbit/s) device interface that is Full Speed (12Mbit/s) compliant. The USB interface is primarily intended for use as command and data interface and for downloading firmware.

The external application is responsible for supplying the VUSB_IN line. This line is used for cable detection only. The USB part (driver and transceiver) is supplied by means of BATT+. This is because PLS62-W is designed as a self-powered device compliant with the “Universal Serial Bus Specification Revision 2.0”¹.

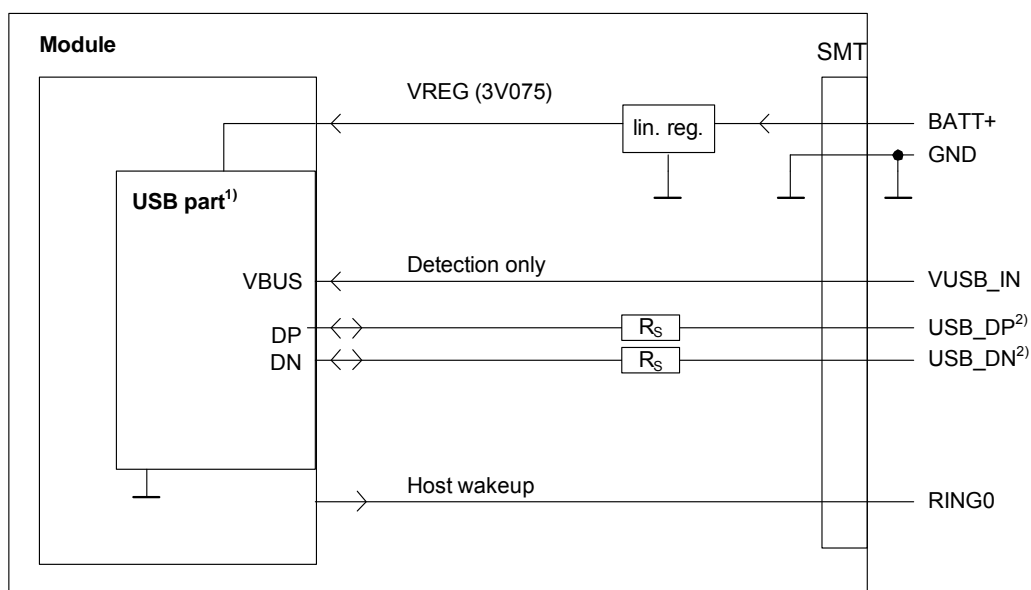

¹) All serial (including R_S) and pull-up resistors for data lines are implemented.

²) If the USB interface is operated in High Speed mode (480MHz), it is recommended to take special care routing the data lines USB_DP and USB_DN. Application layout should in this case implement a differential impedance of 90Ohm for proper signal integrity.

Figure 2: USB circuit

To properly connect the module's USB interface to the external application, a USB 2.0 compatible connector and cable or hardware design is required. Furthermore, the USB modem driver distributed with PLS62-W needs to be installed.

1. The specification is ready for download on <http://www.usb.org/developers/docs/>

2.1.2 Serial Interface ASC0

PLS62-W offers an 8-wire unbalanced, asynchronous modem interface ASC0 conforming to ITU-T V.24 protocol DCE signalling. The electrical characteristics do not comply with ITU-T V.28. The significant levels are 0V (for low data bit or active state) and 1.8V (for high data bit or inactive state).

PLS62-W is designed for use as a DCE. Based on the conventions for DCE-DTE connections it communicates with the customer application (DTE) using the following signals:

- Port TXD @ application sends data to the module's TXD0 signal line
- Port RXD @ application receives data from the module's RXD0 signal line

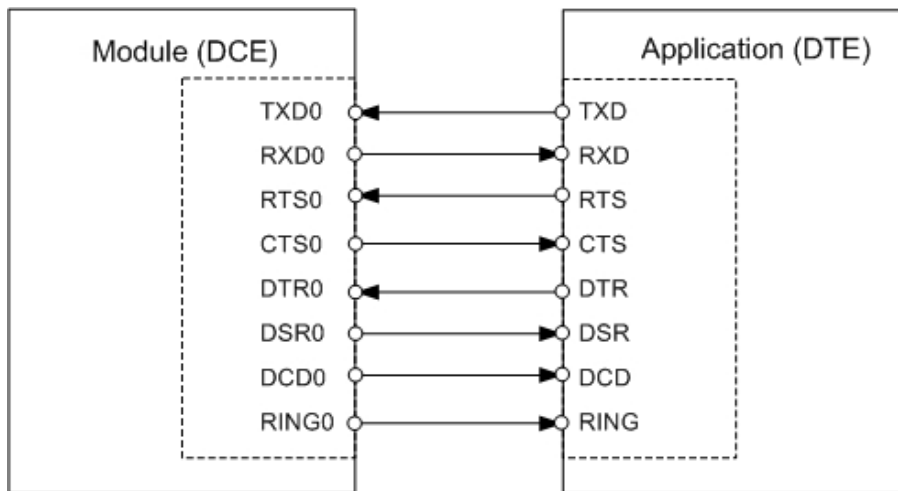

Figure 3: Serial interface ASC0

Features:

- Includes the data lines TXD0 and RXD0, the status lines RTS0 and CTS0 and, in addition, the modem control lines DTR0, DSR0, DCD0 and RING0.
- The RING0 signal serves to indicate incoming calls and other types of URCs (Unsolicited Result Code). It can also be used to send pulses to the host application, for example to wake up the application from power saving state.
- Configured for 8 data bits, no parity and 1 stop bit.
- ASC0 can be operated at fixed bit rates from 1,200bps up to 921,600bps.
- Autobauding supports bit rates from 1,200bps up to 230,400bps.
- Supports RTS0/CTS0 hardware flow control. The hardware hand shake line RTS0 has an internal pull down resistor causing a low level signal, if the line is not used and open. Although hardware flow control is recommended, this allows communication by using only RXD and TXD lines.
- Wake up from SLEEP mode by RTS0 activation.

2.1.3 Serial Interface ASC1

Four PLS62-W GPIO lines can be configured as ASC1 interface signals to provide a 4-wire unbalanced, asynchronous modem interface ASC1 conforming to ITU-T V.24 protocol DCE signalling. The electrical characteristics do not comply with ITU-T V.28. The significant levels are 0V (for low data bit or active state) and 1.8V (for high data bit or inactive state).

PLS62-W is designed for use as a DCE. Based on the conventions for DCE-DTE connections it communicates with the customer application (DTE) using the following signals:

- Port TXD @ application sends data to module's TXD1 signal line
- Port RXD @ application receives data from the module's RXD1 signal line

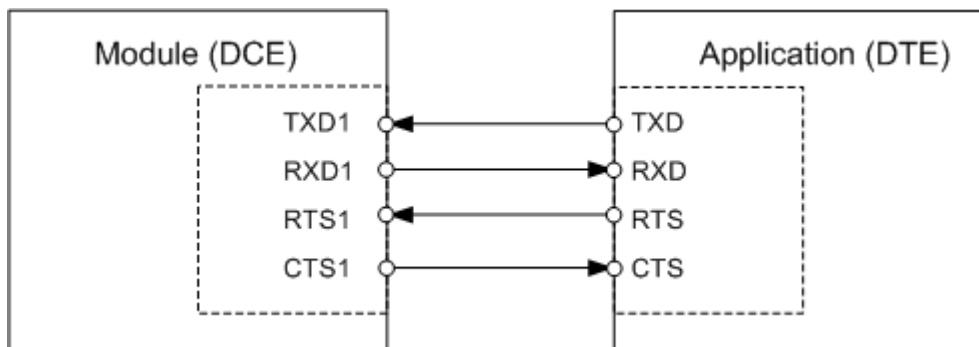

Figure 4: Serial interface ASC1

Features

- Includes only the data lines TXD1 and RXD1 plus RTS1 and CTS1 for hardware hand-shake.
- On ASC1 no RING line is available.
- Configured for 8 data bits, no parity and 1 or 2 stop bits.
- ASC1 can be operated at fixed bit rates from 1,200 bps to 921,600 bps.
- Autobauding supports bit rates from 1,200bps up to 230,400bps.
- Supports RTS1/CTS1 hardware flow. The hardware hand shake line RTS0 has an internal pull down resistor causing a low level signal, if the line is not used and open. Although hardware flow control is recommended, this allows communication by using only RXD and TXD lines.

2.1.4 UICC/SIM/USIM Interface

PLS62-W has two UICC/SIM/USIM interfaces compatible with the 3GPP 31.102 and ETSI 102 221. These are wired to the host interface in order to be connected to an external SIM card holder. Five pads on the SMT application interface are reserved for each of the two SIM interfaces.

The UICC/SIM/USIM interface supports 3V and 1.8V SIM cards.

The CCINx signal serves to detect whether a tray (with SIM card) is present in the card holder. Using the CCINx signal is mandatory for compliance with the GSM 11.11 recommendation if the mechanical design of the host application allows the user to remove the SIM card during operation. To take advantage of this feature, an appropriate SIM card detect switch is required on the card holder. For example, this is true for the model supplied by Molex, which has been tested to operate with PLS62-W and is part of the Gemalto M2M reference equipment submitted for type approval. See [Chapter 7](#) for Molex ordering numbers.

Table 1: Signals of the SIM interface (SMT application interface)

Signal	Description
GND	Ground connection for SIM interfaces. Optionally a separate SIM ground line using e.g., pad P12, may be used to improve EMC.
CCCLK1 CCCLK2	Chipcard clock lines for 1 st and 2 nd SIM interface.
CCVCC1 CCVCC2	SIM supply voltage lines for 1 st and 2 nd SIM interface.
CCIO1 CCIO2	Serial data lines for 1 st and 2 nd SIM interface, input and output.
CCRST1 CCRST2	Chipcard reset lines for 1 st and 2 nd SIM interface.
CCIN1 CCIN2	Input on the baseband processor for detecting a SIM card tray in the holder. If the SIM is removed during operation the SIM interface is shut down immediately to prevent destruction of the SIM. The CCINx signal is active low. The CCINx signal is mandatory for applications that allow the user to remove the SIM card during operation. The CCINx signal is solely intended for use with a SIM card. It must not be used for any other purposes. Failure to comply with this requirement may invalidate the type approval of PLS62-W.

Note: No guarantee can be given, nor any liability accepted, if loss of data is encountered after removing the SIM card during operation. Also, no guarantee can be given for properly initializing any SIM card that the user inserts after having removed the SIM card during operation. In this case, the application must restart PLS62-W.

By default, only the module's 1st SIM interface is available and can be used. Using SIM_SWITCH line it is possible to switch between the two SIM interfaces (see [Section 2.1.4.1](#)).

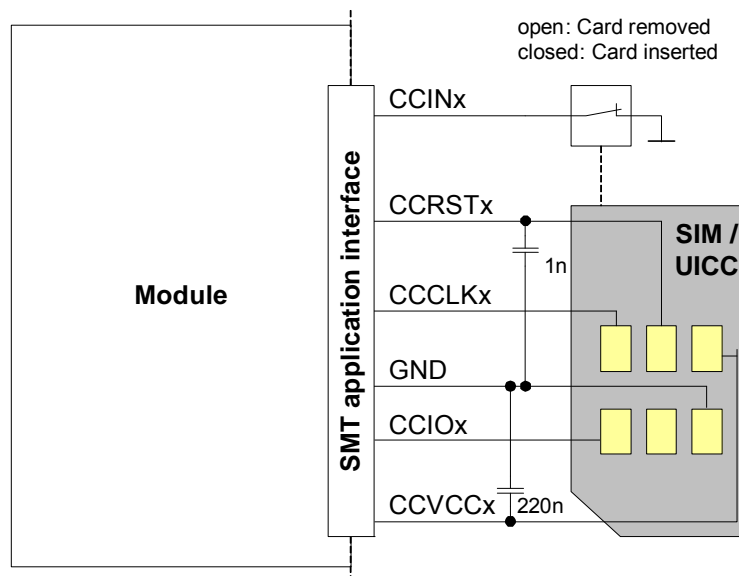

Figure 5: UICC/SIM/USIM interfaces

The total cable length between the SMT application interface pads on PLS62-W and the pads of the external SIM card holder must not exceed 100mm in order to meet the specifications of 3GPP TS 51.010-1 and to satisfy the requirements of EMC compliance.

To avoid possible cross-talk from the CCCLKx signal to the CCIOx signal be careful that both lines are not placed closely next to each other. A useful approach is using the GND line to shield the CCIOx line from the CCCLKx line.

2.1.4.1 SIM Card Interface Switch

Using the SIM_SWITCH line allows to switch between two SIM card interfaces. The usage of both interfaces is mutually exclusive. The GPIO26 line can be configured as SIM_SWITCH by means of AT-Command. If set to low, the 1st SIM card interface will be used, if set to high the 2nd SIM card interface will be used.

The configuration of the SIM_SWITCH line is done via AT command, is non-volatile, and available after the next module restart.

2.1.5 GPIO Interface

PLS62-W offers a GPIO interface with 24 GPIO lines. The GPIO lines are shared with other interfaces or functions: Fast shutdown (see [Section 2.1.10.1](#)), status LED (see [Section 2.1.10](#)), the PWM functionality (see [Section 2.1.8](#)), an pulse counter (see [Section 2.1.9](#)), ASC0 (see [Section 2.1.2](#)), ASC1 (see [Section 2.1.3](#)), an SPI interface (see [Section 2.1.7](#)).

The following table shows the configuration variants for the GPIO pads. All variants are mutually exclusive, i.e. a pad configured for instance as Status LED is locked for alternative usage.

Table 2: GPIO lines and possible alternative assignment

GPIO	Fast Shutdown	Status LED	PWM	Pulse Counter	ASC0	ASC1	SPI	SIM SWITCH
GPIO1					DTR0			
GPIO2					DCD0			
GPIO3					DSR0		SPI_CLK	
GPIO4	FST_SHDN							
GPIO5		Status LED						
GPIO6			PWM2					
GPIO7			PWM1					
GPIO8				COUNTER				
GPIO11								
GPIO12								
GPIO13								
GPIO14								
GPIO15								
GPIO16						RXD1	SPI_MOSI	
GPIO17						TXD1	SPI_MISO	
GPIO18						RTS1		
GPIO19						CTS1	SPI_CS	
GPIO20								
GPIO21								
GPIO22								
GPIO23								
GPIO24					RING0			
GPIO25								
GPIO26								SIM_SWITCH

After startup, the above mentioned alternative GPIO line assignments can be configured using AT commands (see [\[1\]](#)). The configuration is non-volatile and available after module restart.

2.1.6 I²C Interface

I²C is a serial, 8-bit oriented data transfer bus for bit rates up to 400kbps in Fast mode. It consists of two lines, the serial data line I2CDAT and the serial clock line I2CCLK. The module acts as a single master device, e.g. the clock I2CCLK is driven by the module. I2CDAT is a bi-directional line. Each device connected to the bus is software addressable by a unique 7-bit address, and simple master/slave relationships exist at all times. The module operates as master-transmitter or as master-receiver. The customer application transmits or receives data only on request of the module.

The I²C interface can be powered via the V180 line of PLS62-W. If connected to the V180 line, the I²C interface will properly shut down when the module enters the Power Down mode.

Note: Good care should be taken when creating the PCB layout of the host application: The traces of I2CCLK and I2CDAT should be equal in length and as short as possible.

2.1.7 SPI Interface

Four PLS62-W GPIO interface lines can be configured as Serial Peripheral Interface (SPI). The SPI is a synchronous serial interface for control and data transfer between PLS62-W and the external application. Only one application can be connected to the SPI and the interface supports only master mode. The transmission rates are up to 6.5Mbit/s. The SPI interface comprises the two data lines SPI_MOSI and SPI_MISO, the clock line SPI_CLK as well as the chip select line SPI_CS.

2.1.8 PWM Interfaces

The GPIO6 and GPIO7 interface lines can be configured as Pulse Width Modulation interface lines PWM1 and PWM2. The PWM interface lines can be used, for example, to connect buzzers. The PWM1 line is shared with GPIO7 and the PWM2 line is shared with GPIO6 (for GPIOs see [Section 2.1.5](#)). GPIO and PWM functionality are mutually exclusive.

2.1.9 Pulse Counter

The GPIO8 line can be configured as pulse counter line COUNTER. The pulse counter interface can be used, for example, as a clock (for GPIOs see [Section 2.1.5](#)).

2.1.10 Status LED

The GPIO5 interface line can be configured to drive a status LED that indicates different operating modes of the module (for GPIOs see [Section 2.1.5](#)). GPIO and LED functionality are mutually exclusive.

2.1.10.1 Fast Shutdown

The GPIO4 interface line can be configured as fast shutdown signal line FST_SHDN. The configured FST_SHDN line is an active low control signal and must be applied for at least 1 millisecond. If unused this line can be left open because of a configured internal pull-up resistor.

2.1.11 700MHz Antenna Switch Control

To provide for an antenna optimization over a wide frequency range, the ANT_SWITCH line may act as a control signal for a possible external antenna switch that is able to change between an antenna covering the 700MHz band and an antenna covering all other bands - depending on the frequency band currently being used by the module.

The ANT_SWITCH line is set to "high" (1) if the module is employing frequencies in the 700 MHz range (i.e., LTE band 17) and "low" (0) for all other frequencies, including the 800/850 MHz frequency bands.

The ANT_SWITCH signal is triggered by all module internal activities involving a change of the used frequency, even if only temporary (e.g., inter-band scanning using compressed mode). The maximum delay/deviation between internal usage change of the frequency band, and the GPIO2 signal change is 10 microseconds.

2.1.12 TX Activity Signal

The TX_ACTIVITY line indicates any 2G/3G/4G TX activity of the module, meaning a high level on this line signals that the module is transmitting data.

2.2 RF Antenna Interface

The PLS62-W GSM/UMTS/LTE antenna interface comprises a GSM/UMTS/LTE main antenna as well as a UMTS/LTE Rx diversity antenna to improve signal reliability and quality¹. The RF interface has an impedance of 50Ω. PLS62-W is capable of sustaining a total mismatch at the antenna line without any damage, even when transmitting at maximum RF power.

The external antenna must be matched properly to achieve best performance regarding radiated power, modulation accuracy and harmonic suppression. Antenna matching networks are not included on the PLS62-W module and should be placed in the host application if the antenna does not have an impedance of 50Ω.

Regarding the return loss PLS62-W provides the following values in the active band:

Table 3: Return loss in the active band

State of module	Return loss of module	Recommended return loss of application
Receive	≥ 8dB	≥ 12dB
Transmit	not applicable	≥ 12dB

1. By delivery default the UMTS/LTE Rx diversity antenna is configured as available for the module since its usage is mandatory for LTE. Please refer to [1] for details on how to configure antenna settings.

2.2.1 Antenna Installation

The antenna is connected by soldering the antenna pads (ANT_MAIN and ANT_DRX) and their neighboring ground pads directly to the application's PCB.

The distance between the antenna pads and their neighboring GND pads has been optimized for best possible impedance. To prevent mismatch, special attention should be paid to these pads on the application's PCB.

The wiring of the antenna connection, starting from the antenna pad to the application's antenna should result in a 50Ω line impedance. Line width and distance to the GND plane need to be optimized with regard to the PCB's layer stack.

To prevent receiver desensitization due to interferences generated by fast transients like high speed clocks on the external application PCB, it is recommended to realize the antenna connection line using embedded Stripline rather than Micro-Stripline technology.

For type approval purposes, the use of a 50Ω coaxial antenna connector (U.FL-R-SMT) might be necessary. In this case the U.FL-R-SMT connector should be placed as close as possible to PLS62-W's antenna pad.

2.2.2 RF Line Routing Design

2.2.2.1 Line Arrangement Examples

Several dedicated tools are available to calculate line arrangements for specific applications and PCB materials - for example from <http://www.polarinstruments.com/> (commercial software) or from <http://web.awrcorp.com/Usa/Products/Optional-Products/TX-Line/> (free software).

Embedded Stripline

This figure below shows a line arrangement example for embedded stripline with $65\mu\text{m}$ FR4 prepreg (type: 1080) and $710\mu\text{m}$ FR4 core (4-layer PCB).

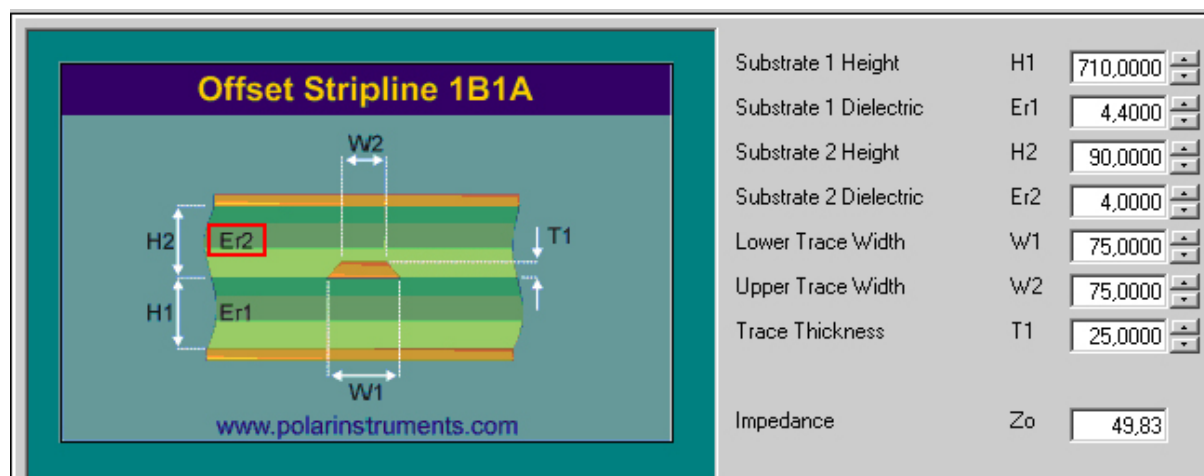

Figure 6: Embedded Stripline with $65\mu\text{m}$ prepreg (1080) and $710\mu\text{m}$ core

Micro-Stripline

This section gives two line arrangement examples for micro-stripline.

- Micro-Stripline on 1.0mm Standard FR4 2-Layer PCB
The following two figures show examples with different values for D1 (ground strip separation).

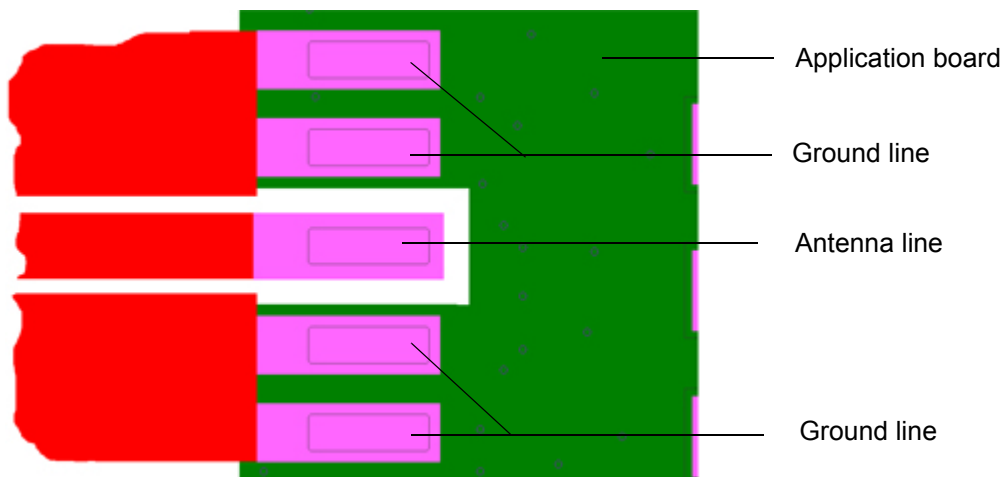
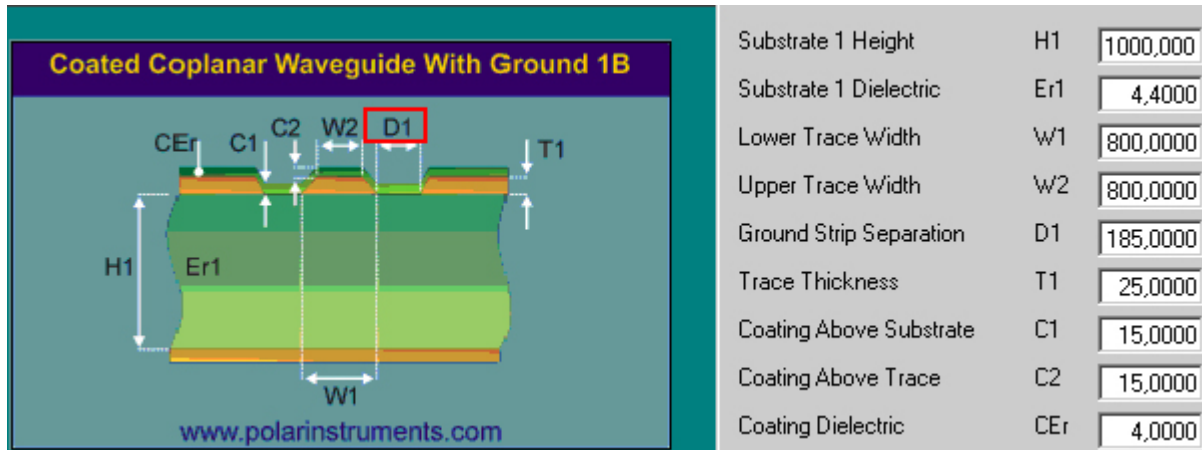

Figure 7: Micro-Stripline on 1.0mm standard FR4 2-layer PCB - example 1

2.2 RF Antenna Interface

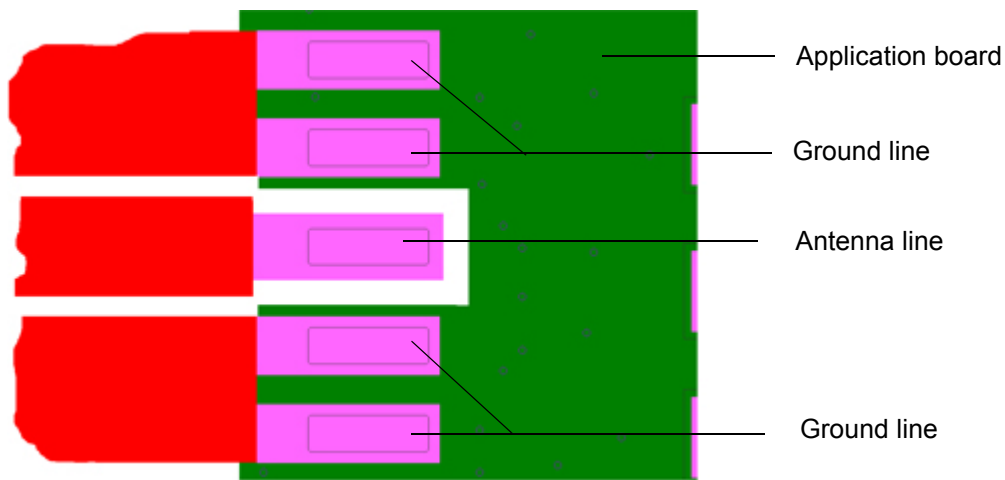
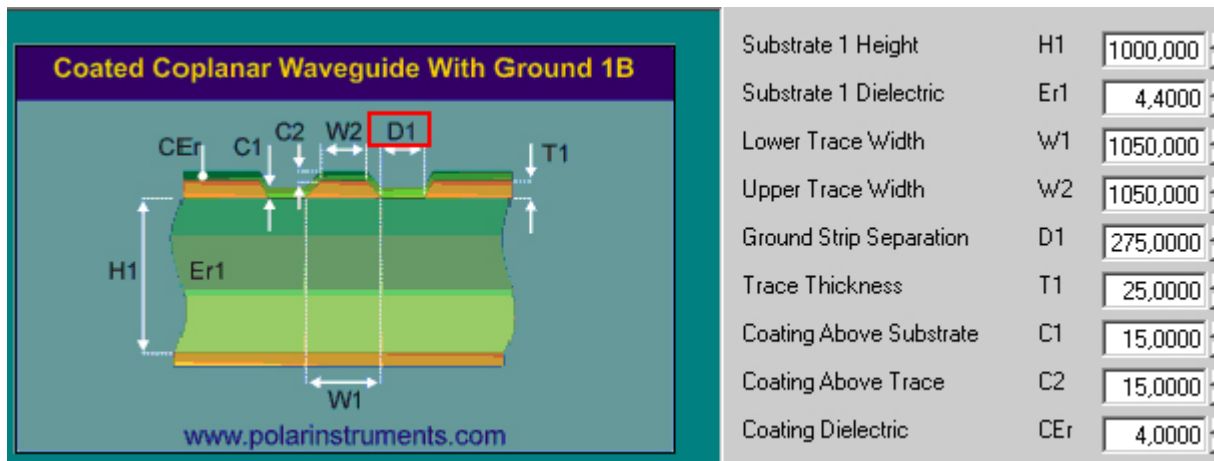

Figure 8: Micro-Stripline on 1.0mm Standard FR4 PCB - example 2

2.2 RF Antenna Interface

- Micro-Stripline on 1.5mm Standard FR4 2-Layer PCB
The following two figures show examples with different values for D1 (ground strip separation).

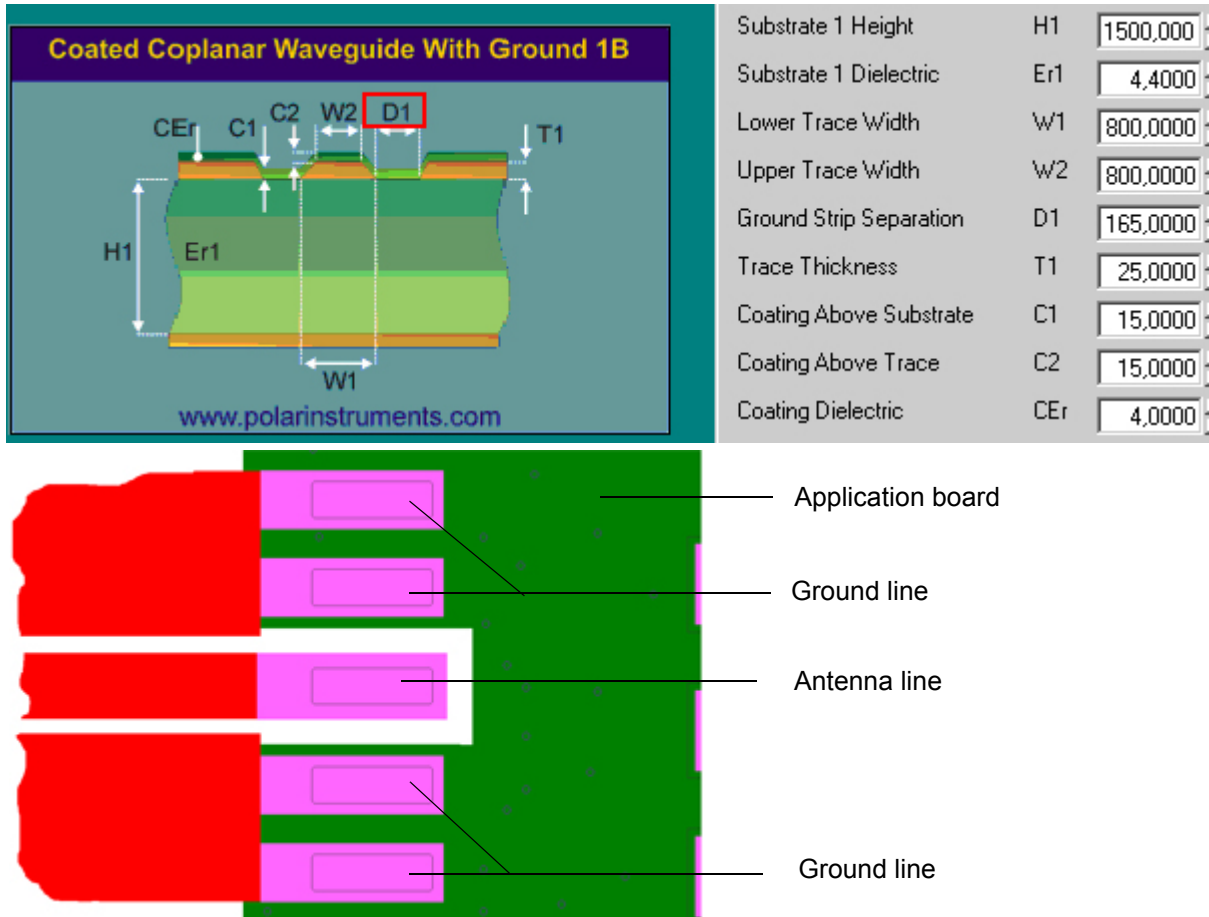

Figure 9: Micro-Stripline on 1.5mm Standard FR4 PCB - example 1

2.2 RF Antenna Interface

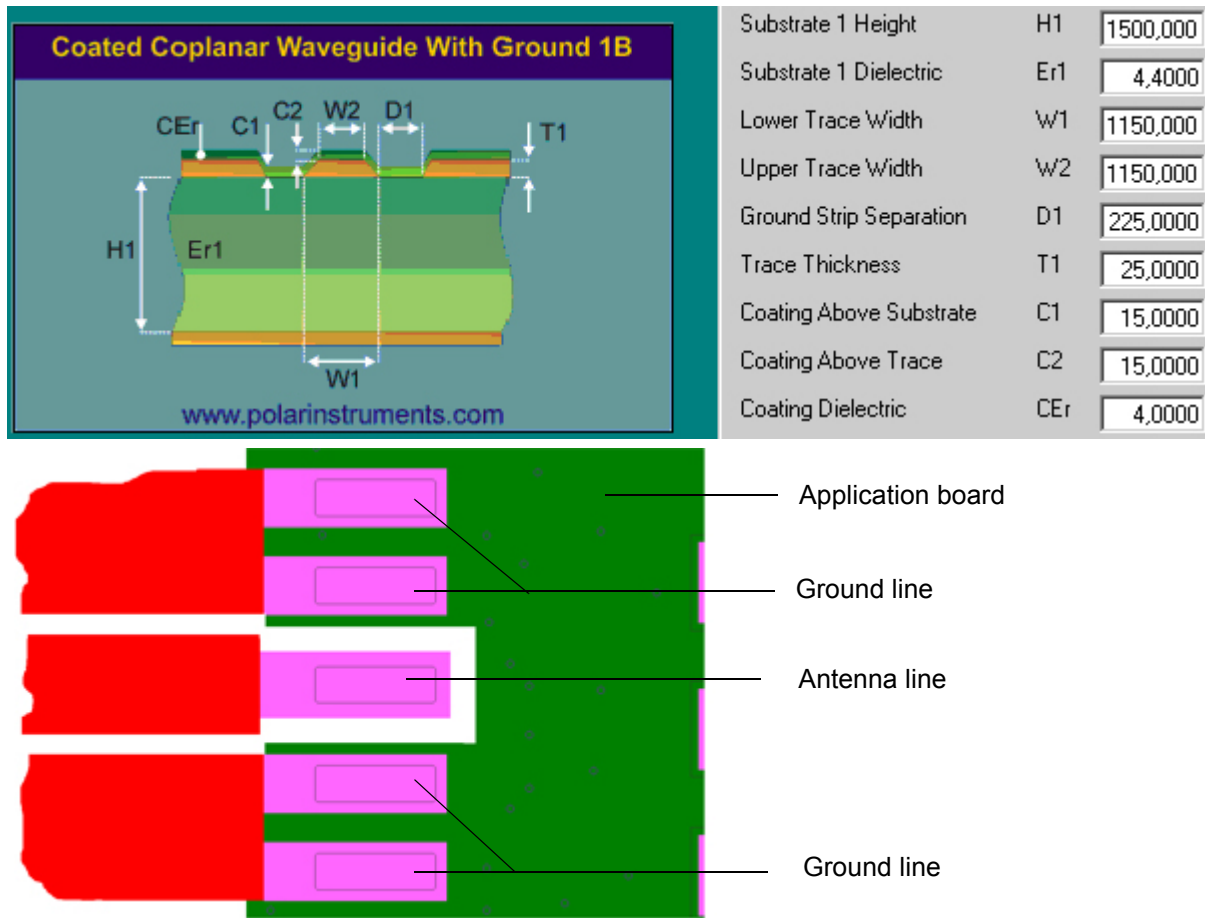

Figure 10: Micro-Stripline on 1.5mm Standard FR4 PCB - example 2

2.2.2.2 Routing Example

Interface to RF Connector

Figure 11 shows a sample connection of a module's antenna pad at the bottom layer of the module PCB with an application PCB's coaxial antenna connector. Line impedance depends on line width, but also on other PCB characteristics like dielectric, height and layer gap. The sample stripline width of 0.33mm is recommended for an application with a PCB layer stack resembling the one of the PLS62-W evaluation board shown in Figure 12. For different layer stacks the stripline width will have to be adapted accordingly.

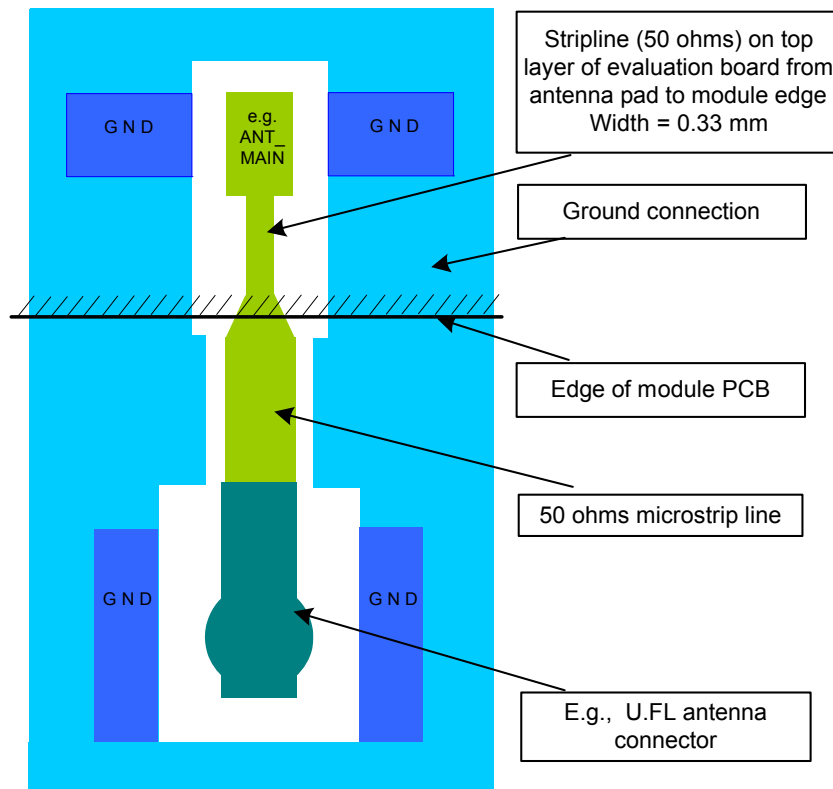

Figure 11: Routing to application's RF connector

Layer No.	Construction	Finished thickness (um)
s/m		15
1		25
	Prepreg :1080X1 RC:64%	65
2		25
	CORE:28mil H/Hoz 7628x4	708
3		25
	Prepreg :1080X1 RC:64%	65
4		25
s/m		15
	Total thickness (including S/M):	968

Figure 12: PLS62-W evaluation board layer table

2.3 Sample Application

Figure 13 shows a typical example of how to integrate a PLS62-W module with an application. Usage of the various host interfaces depends on the desired features of the application.

Because of the very low power consumption design, current flowing from any other source into the module circuit must be avoided, for example reverse current from high state external control lines. Therefore, the controlling application must be designed to prevent reverse current flow. Otherwise there is the risk of undefined states of the module during startup and shutdown or even of damaging the module.

Because of the high RF field density inside the module, it cannot be guaranteed that no self interference might occur, depending on frequency and the applications grounding concept. The potential interferers may be minimized by placing small capacitors (47pF) at suspected lines (e.g. RXD0, VDDL, and ON).

While developing SMT applications it is strongly recommended to provide test points for certain signals, i.e., lines to and from the module - for debug and/or test purposes. The SMT application should allow for an easy access to these signals. For details on how to implement test points see [3].

The EMC measures are best practice recommendations. In fact, an adequate EMC strategy for an individual application is very much determined by the overall layout and, especially, the position of components.

Note: PLS62-W is not intended for use with cables longer than 3m.

Disclaimer

No warranty, either stated or implied, is provided on the sample schematic diagram shown in Figure 13 and the information detailed in this section. As functionality and compliance with national regulations depend to a great amount on the used electronic components and the individual application layout manufacturers are required to ensure adequate design and operating safeguards for their products using PLS62-W modules.

2.3 Sample Application

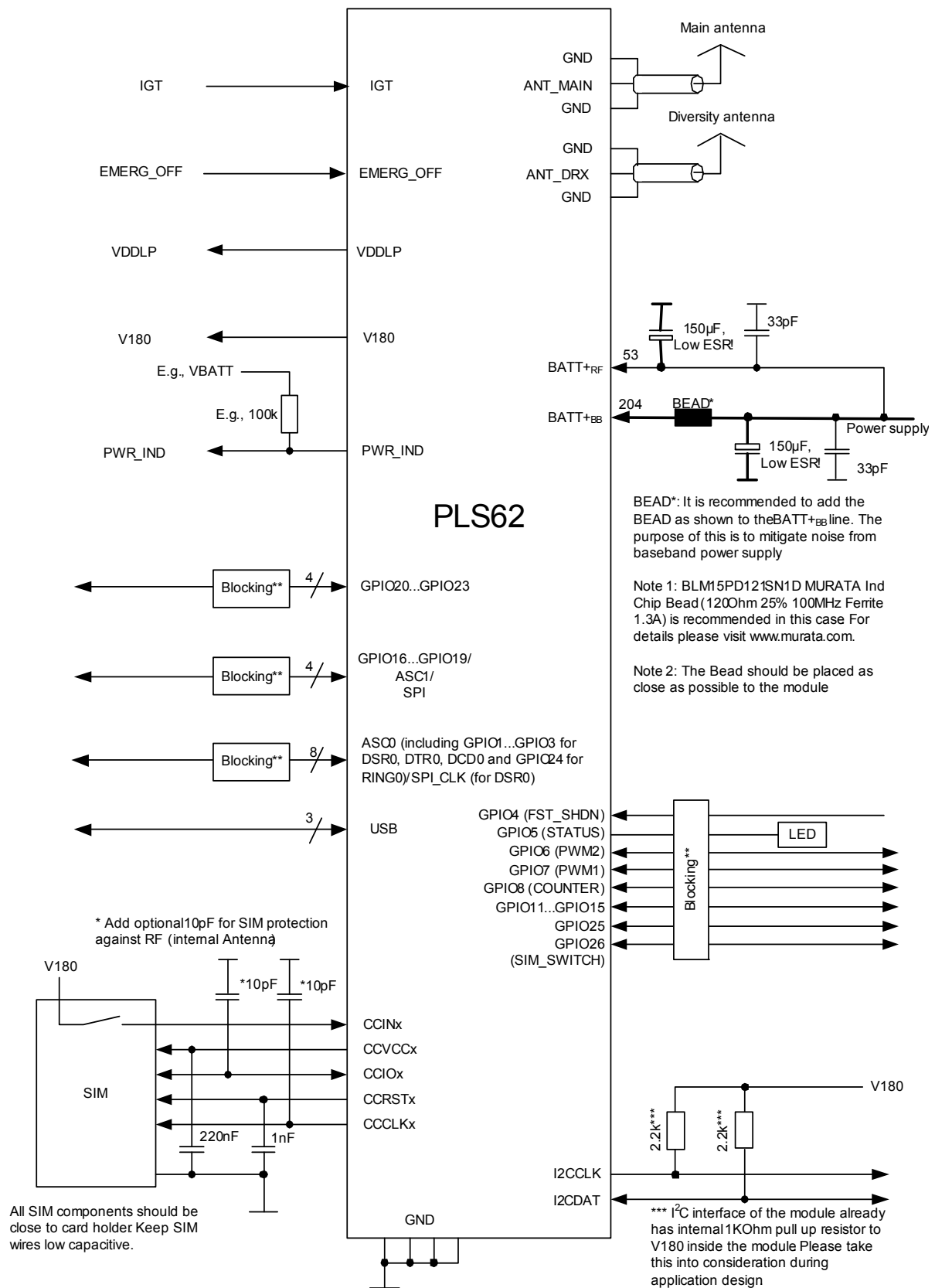

Figure 13: Schematic diagram of PLS62-W sample application

3 Operating Characteristics

3.1 Operating Modes

The table below briefly summarizes the various operating modes referred to throughout the document.

Mode	Function	
Normal operation	GSM / GPRS / UMTS / HSPA / LTE SLEEP	Power saving set automatically when no call is in progress and the USB connection is suspended by host or not present and no active communication via ASC0.
	GSM / GPRS / UMTS / HSPA / LTE IDLE	Power saving disabled or an USB connection not suspended, but no call in progress.
	GSM TALK/ GSM DATA	Connection between two subscribers is in progress. Power consumption depends on the GSM network coverage and several connection settings (e.g. DTX off/on, FR/EFR/HR, hopping sequences and antenna connection). The following applies when power is to be measured in TALK_GSM mode: DTX off, FR and no frequency hopping.
	GPRS DATA	GPRS data transfer in progress. Power consumption depends on network settings (e.g. power control level), uplink / downlink data rates and GPRS configuration (e.g. used multislot settings).
	EGPRS DATA	EGPRS data transfer in progress. Power consumption depends on network settings (e.g. power control level), uplink / downlink data rates and EGPRS configuration (e.g. used multislot settings).
	UMTS TALK/ UMTS DATA	UMTS data transfer in progress. Power consumption depends on network settings (e.g. TPC Pattern) and data transfer rate.
	HSPA DATA	HSPA data transfer in progress. Power consumption depends on network settings (e.g. TPC Pattern) and data transfer rate.
	LTE DATA	LTE data transfer in progress. Power consumption depends on network settings (e.g. TPC Pattern) and data transfer rate.
Power Down	Normal shutdown after sending the power down command. Only a voltage regulator is active for powering the RTC. Software is not active. Interfaces are not accessible. Operating voltage remains applied.	
Airplane mode	Airplane mode shuts down the radio part of the module, causes the module to log off from the network and disables all AT commands whose execution requires a radio connection. Airplane mode can be controlled by AT command (see [1]).	

3.2 Power Supply

PLS62-W needs to be connected to a power supply at the SMT application interface - 4 lines BATT+, and GND. There are two separate voltage domains for BATT+:

- BATT+_{BB} with two lines for the general power management.
- BATT+_{RF} with four lines for the GSM power amplifier supply.

Please note that throughout the document BATT+ refers to both voltage domains and power supply lines - BATT+_{BB} and BATT+_{RF}.

The main power supply from an external application has to be a single voltage source and has to be expanded to sub paths (star structure).

All the key functions for supplying power to the device are handled by the power management section of the analog controller. This IC provides the following features:

- Stabilizes the supply voltages for the baseband using low drop linear voltage regulators and a DC-DC step down switching regulator.
- Switches the module's power voltages for the power-up and -down procedures.
- SIM switch to provide SIM power supply.

4 Mechanical Dimensions, Mounting and Packaging

4.1 Mechanical Dimensions of PLS62-W

Figure 14 shows the top and bottom view of PLS62-W and provides an overview of the board's mechanical dimensions. For further details see Figure 15.

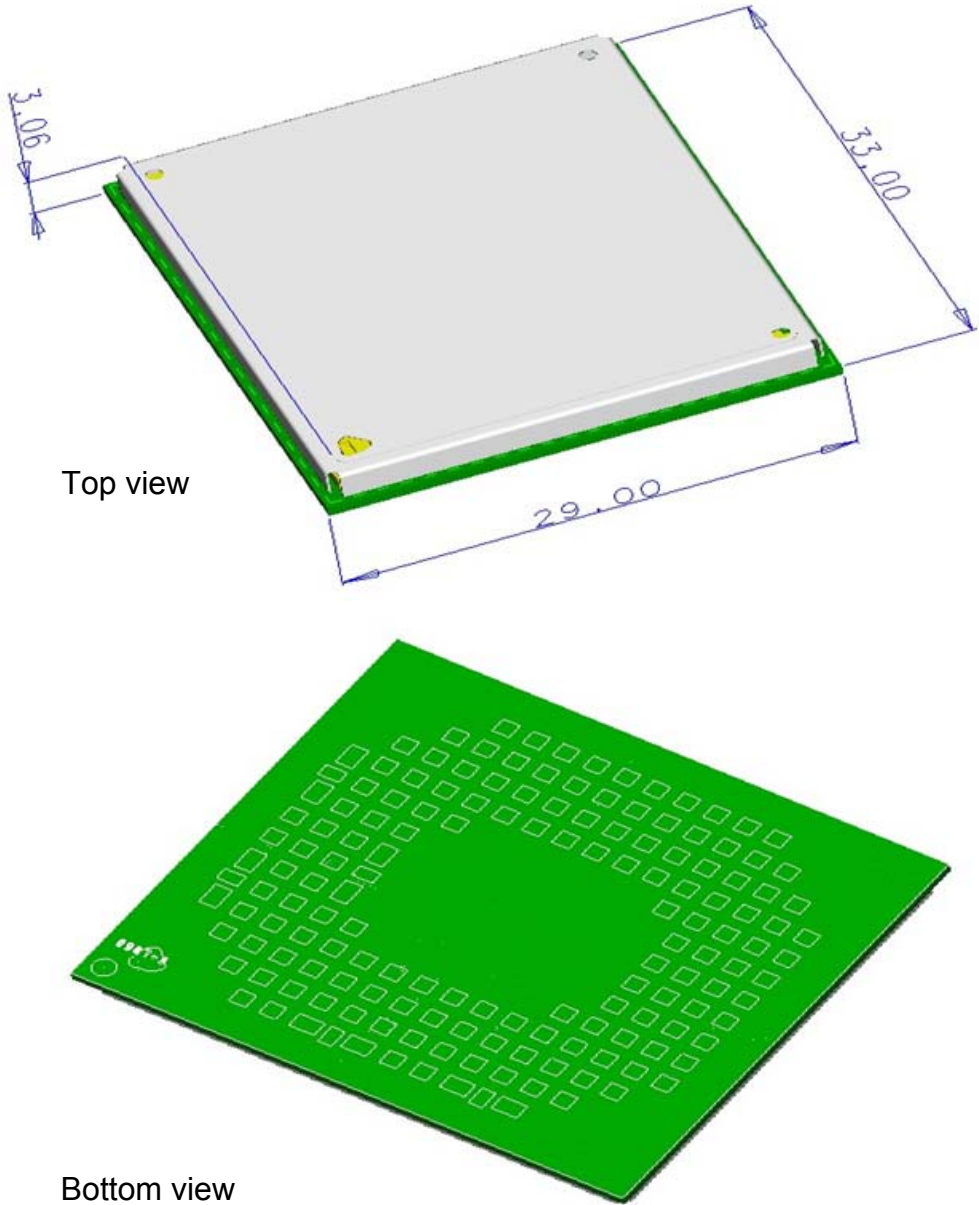

Figure 14: PLS62-W– top and bottom view

4.1 Mechanical Dimensions of PLS62-W

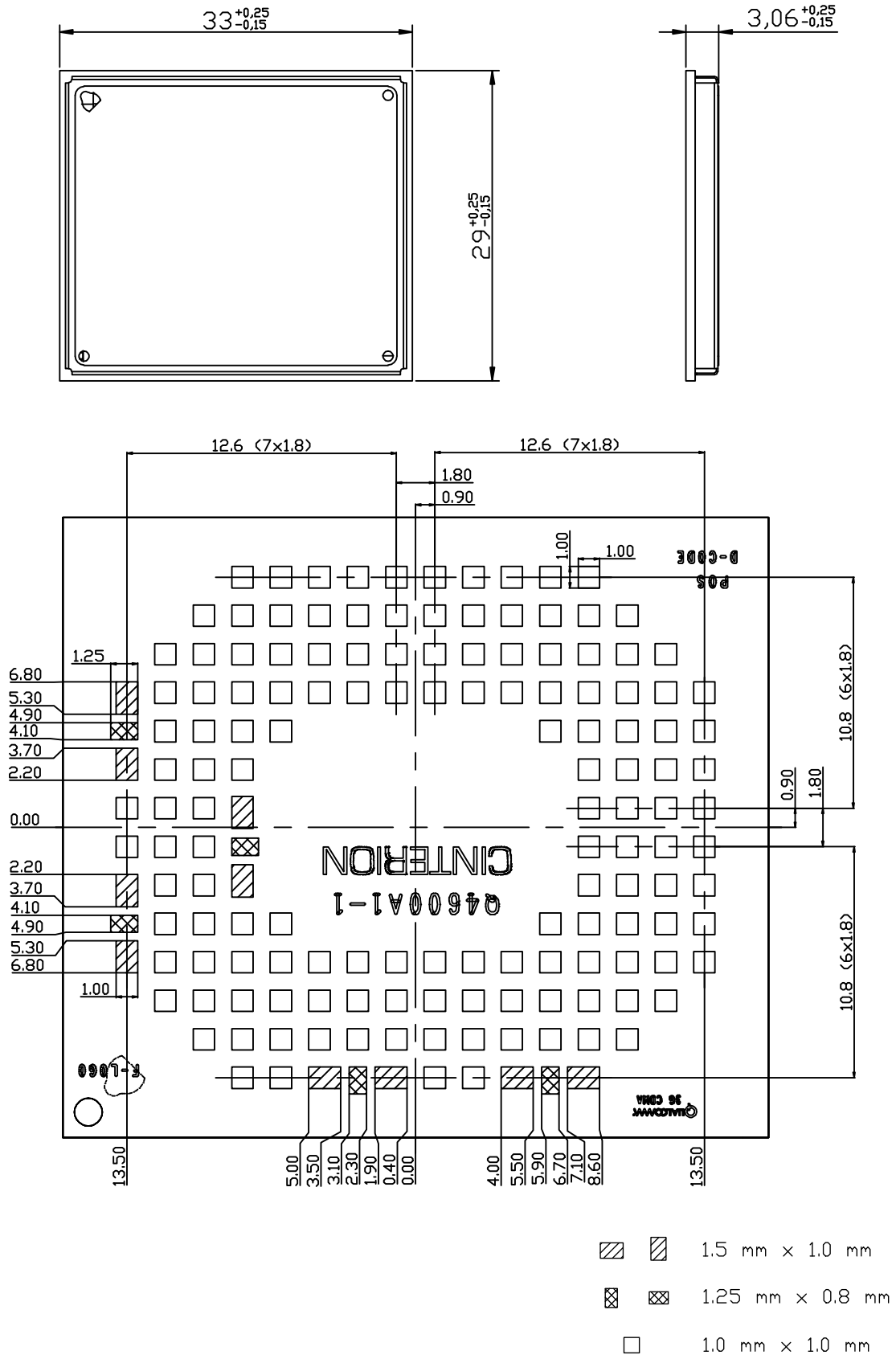

Figure 15: Dimensions of PLS62-W (all dimensions in mm)

5 Regulatory and Type Approval Information

5.1 Directives and Standards

PLS62-W is designed to comply with the directives and standards listed below.

It is the responsibility of the application manufacturer to ensure compliance of the final product with all provisions of the applicable directives and standards as well as with the technical specifications provided in the "PLS62-W Hardware Interface Description".¹

Table 4: Directives



2014/53/EU	Directive of the European Parliament and of the council of 16 April 2014 on the harmonization of the laws of the Member States relating to the making available on the market of radio equipment and repealing Directive 1999/05/EC. The product is labeled with the CE conformity mark.	
2002/95/EC (RoHS 1) 2011/65/EC (RoHS 2)	Directive of the European Parliament and of the Council of 27 January 2003 (and revised on 8 June 2011) on the restriction of the use of certain hazardous substances in electrical and electronic equipment (RoHS)	

Table 5: Standards of North American type approval

CFR Title 47	Code of Federal Regulations, Part 22, Part 24; US Equipment Authorization FCC	
OET Bulletin 65 (Edition 97-01)	Evaluating Compliance with FCC Guidelines for Human Exposure to Radiofrequency Electromagnetic Fields	
UL 60 950-1	Product Safety Certification (Safety requirements)	
NAPRD.03 V5.24	Overview of PCS Type certification review board Mobile Equipment Type Certification and IMEI control PCS Type Certification Review board (PTCRB)	
RSS132, RSS133, RSS139	Canadian Standard	

Table 6: Standards of European type approval

3GPP TS 51.010-1	Digital cellular telecommunications system (Release 7); Mobile Station (MS) conformance specification;
ETSI EN 301 511 V12.5.1	Global System for Mobile communications (GSM); Mobile Stations (MS) equipment; Harmonized Standard covering the essential requirements of article 3.2 of Directive 2014/53/EU
GCF-CC V3.62.1	Global Certification Forum - Certification Criteria

1. Manufacturers of applications which can be used in the US shall ensure that their applications have a PTCRB approval. For this purpose they can refer to the PTCRB approval of the respective module.

5.1 Directives and Standards

Table 6: Standards of European type approval

Draft ETSI EN 301 489-01 V2.2.0	Electromagnetic Compatibility (EMC) standard for radio equipment and services; Part 1: Common technical requirements; Harmonized Standard covering the essential requirements of article 3.1(b) of Directive 2014/53/EU and the essential requirements of article 6 of Directive 2014/30/EU
Draft ETSI EN 301 489-52 V1.1.0	Electromagnetic Compatibility (EMC) standard for radio equipment and services; Part 52: Specific conditions for Cellular Communication Mobile and portable (UE) radio and ancillary equipment; Harmonized Standard covering the essential requirements of article 3.1(b) of Directive 2014/53/EU
ETSI EN 301 908-01 V11.1.1	IMT cellular networks; Harmonized Standard covering the essential requirements of article 3.2 of the Directive 2014/53/EU; Part 1: Introduction and common requirements
ETSI EN 301 908-02 V11.1.1	IMT cellular networks; Harmonized Standard covering the essential requirements of article 3.2 of the Directive 2014/53/EU; Part 2: CDMA Direct Spread (UTRA FDD) User Equipment (UE)
ETSI EN 301 908-13 V11.1.1	IMT cellular networks; Harmonized Standard covering the essential requirements of article 3.2 of the Directive 2014/53/EU; Part 13: Evolved Universal Terrestrial Radio Access (E-UTRA) User Equipment (UE)
EN 60950-1:2006/A11:2009+A1:2010+A12:2011+A2:2013	Safety of information technology equipment

Table 7: Requirements of quality

IEC 60068	Environmental testing
DIN EN 60529	IP codes

Table 8: Standards of the Ministry of Information Industry of the People's Republic of China

SJ/T 11363-2006	"Requirements for Concentration Limits for Certain Hazardous Substances in Electronic Information Products" (2006-06).
SJ/T 11364-2006	<p>"Marking for Control of Pollution Caused by Electronic Information Products" (2006-06).</p> <p>According to the "Chinese Administration on the Control of Pollution caused by Electronic Information Products" (ACPEIP) the EPUP, i.e., Environmental Protection Use Period, of this product is 20 years as per the symbol shown here, unless otherwise marked. The EPUP is valid only as long as the product is operated within the operating limits described in the Gemalto M2M Hardware Interface Description.</p> <p>Please see Table 9 for an overview of toxic or hazardous substances or elements that might be contained in product parts in concentrations above the limits defined by SJ/T 11363-2006.</p> 

5.1 Directives and Standards

Table 9: Toxic or hazardous substances or elements with defined concentration limits

部件名称 Name of the part	有毒有害物质或元素 Hazardous substances					
	铅 (Pb)	汞 (Hg)	镉 (Cd)	六价铬 (Cr(VI))	多溴联苯 (PBB)	多溴二苯醚 (PBDE)
金属部件 (Metal Parts)	○	○	○	○	○	○
电路模块 (Circuit Modules)	X	○	○	○	○	○
电缆及电缆组件 (Cables and Cable Assemblies)	○	○	○	○	○	○
塑料和聚合物部件 (Plastic and Polymeric parts)	○	○	○	○	○	○

O:
表示该有毒有害物质在该部件所有均质材料中的含量均在SJ/T11363-2006 标准规定的限量要求以下。
Indicates that this toxic or hazardous substance contained in all of the homogeneous materials for this part is below the limit requirement in SJ/T11363-2006.

X:
表示该有毒有害物质至少在该部件的某一均质材料中的含量超出SJ/T11363-2006标准规定的限量要求。
Indicates that this toxic or hazardous substance contained in at least one of the homogeneous materials used for this part *might exceed* the limit requirement in SJ/T11363-2006.

5.2 SAR requirements specific to portable mobiles

Mobile phones, PDAs or other portable transmitters and receivers incorporating a GSM/UMTS module must be in accordance with the guidelines for human exposure to radio frequency energy. This requires the Specific Absorption Rate (SAR) of portable PLS62-W based applications to be evaluated and approved for compliance with national and/or international regulations.

Since the SAR value varies significantly with the individual product design manufacturers are advised to submit their product for approval if designed for portable use. For European/US/Australian-markets the relevant directives are mentioned below. It is the responsibility of the manufacturer of the final product to verify whether or not further standards, recommendations or directives are in force outside these areas.

Products intended for sale on US markets

ES 59005/ANSI C95.1 Considerations for evaluation of human exposure to Electromagnetic Fields (EMFs) from Mobile Telecommunication Equipment (MTE) in the frequency range 30MHz - 6GHz

Products intended for sale on European markets

EN 50360	Product standard to demonstrate the compliance of mobile phones with the basic restrictions related to human exposure to electromagnetic fields (300MHz - 3GHz)
EN 62311:2008	Assessment of electronic and electrical equipment related to human exposure restrictions for electromagnetic fields (0 Hz - 300 GHz)

Please note that SAR requirements are specific only for portable devices and not for mobile devices as defined below:

- **Portable device:**
A portable device is defined as a transmitting device designed to be used so that the radiating structure(s) of the device is/are within 20 centimeters of the body of the user.
- **Mobile device:**
A mobile device is defined as a transmitting device designed to be used in other than fixed locations and to generally be used in such a way that a separation distance of at least 20 centimeters is normally maintained between the transmitter's radiating structure(s) and the body of the user or nearby persons. In this context, the term "fixed location" means that the device is physically secured at one location and is not able to be easily moved to another location.

5.3 Reference Equipment for Type Approval

5.3 Reference Equipment for Type Approval

The Gemalto M2M reference setup submitted to type approve PLS62-W (including a special approval adapter for the DSB75) is shown in the following figure¹:

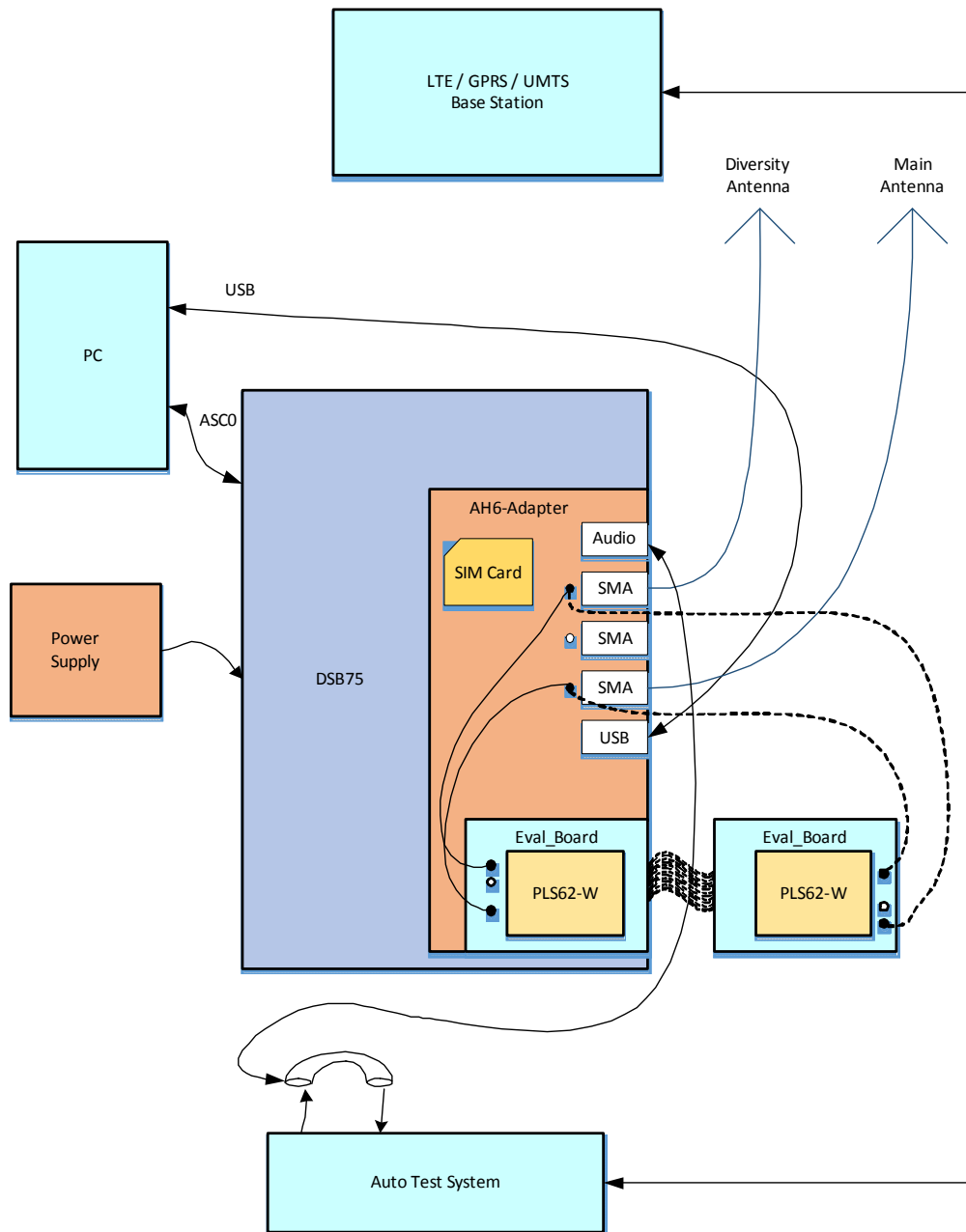

Figure 16: Reference equipment for Type Approval

1. For RF performance tests a mini-SMT/U.FL to SMA adapter with attached 6dB coaxial attenuator is chosen to connect the evaluation module directly to the GSM/UMTS test equipment instead of employing the SMA antenna connectors on the PLS62-W-DSB75 adapter as shown in Figure . The following products are recommended:

Hirose SMA-Jack/U.FL-Plug conversion adapter HRMJ-U.FLP(40)

(for details see <http://www.hirose-connectors.com/> or <http://www.farnell.com/>)

Aeroflex Weinschel Fixed Coaxial Attenuator Model 3T/4T

(for details see <http://www.aeroflex.com/ams/weinschel/pdfs/wmod3&4T.pdf>)

5.4 Compliance with FCC Rules and Regulations

The Equipment Authorization Certification for the Gemalto M2M reference application described in [Section 5.3](#) will be registered under the following identifiers:

FCC Identifier: QIPPLS62-W

Industry Canada Certification Number: 7830A-PLS62W

Granted to Gemalto M2M GmbH

Manufacturers of mobile or fixed devices incorporating PLS62-W modules are authorized to use the FCC Grants and Industry Canada Certificates of the PLS62-W modules for their own final products according to the conditions referenced in these documents. In this case, an FCC/IC label of the module shall be visible from the outside, or the host device shall bear a second label stating "Contains FCC ID: QIPPLS62-W", and accordingly "Contains IC: 7830A-PLS62W". The integration is limited to fixed or mobile categorized host devices, where a separation distance between the antenna and any person of min. 20cm can be assured during normal operating conditions.

For mobile and fixed operation configurations the antenna gain, including cable loss, must not exceed the limits listed in the following [Table 10](#) for FCC and IC.

Table 10: Antenna gain limits for FCC and IC (TBD.)

Operating band	FCC limit	IC limit	Unit
Maximum gain in LTE band2	2.15	2.15	dBi
Maximum gain in LTE band4	2.15	2.15	dBi
Maximum gain in LTE band5	5.15	5.15	dBi
Maximum gain in LTE band7	4.2	4.2	dBi
Maximum gain in LTE band12	2	2	dBi
Maximum gain in LTE band18	5.15	5.15	dBi
Maximum gain in LTE band19	5.15	5.15	dBi
Maximum gain in GSM850	5.15	5.15	dBi
Maximum gain in GSM1900	2.15	2.15	dBi
Maximum gain in GSM850	2.15	2.15	dBi
Maximum gain in GSM850	2.15	2.15	dBi
Maximum gain in GSM850	5.15	5.15	dBi

IMPORTANT:

Manufacturers of portable applications incorporating PLS62-W modules are required to have their final product certified and apply for their own FCC Grant related to the specific portable mobile. This is mandatory to meet the SAR requirements for portable mobiles (see [Section 5.2](#) for detail).

Changes or modifications not expressly approved by the party responsible for compliance could void the user's authority to operate the equipment.

Note: This equipment has been tested and found to comply with the limits for a Class B digital device, pursuant to part 15 of the FCC Rules. These limits are designed to provide reasonable

5.4 Compliance with FCC Rules and Regulations

protection against harmful interference in a residential installation. This equipment generates, uses and can radiate radio frequency energy and, if not installed and used in accordance with the instructions, may cause harmful interference to radio communications. However, there is no guarantee that interference will not occur in a particular installation. If this equipment does cause harmful interference to radio or television reception, which can be determined by turning the equipment off and on, the user is encouraged to try to correct the interference by one or more of the following measures:

- Reorient or relocate the receiving antenna.
- Increase the separation between the equipment and receiver.
- Connect the equipment into an outlet on a circuit different from that to which the receiver is connected.
- Consult the dealer or an experienced radio/TV technician for help.

This Class B digital apparatus complies with Canadian ICES-003.

If Canadian approval is requested for devices incorporating ELS61-US modules the below notes will have to be provided in the English and French language in the final user documentation. Manufacturers/OEM Integrators must ensure that the final user documentation does not contain any information on how to install or remove the module from the final product.

Notes (IC):

(EN) This Class B digital apparatus complies with Canadian ICES-003 and RSS-210. Operation is subject to the following two conditions: (1) this device may not cause interference, and (2) this device must accept any interference, including interference that may cause undesired operation of the device.

(FR) Cet appareil numérique de classe B est conforme aux normes canadiennes ICES-003 et RSS-210. Son fonctionnement est soumis aux deux conditions suivantes: (1) cet appareil ne doit pas causer d'interférence et (2) cet appareil doit accepter toute interférence, notamment les interférences qui peuvent affecter son fonctionnement.

(EN) Radio frequency (RF) Exposure Information

The radiated output power of the Wireless Device is below the Industry Canada (IC) radio frequency exposure limits. The Wireless Device should be used in such a manner such that the potential for human contact during normal operation is minimized.

This device has also been evaluated and shown compliant with the IC RF Exposure limits under mobile exposure conditions. (antennas at least 20cm from a person's body).

(FR) Informations concernant l'exposition aux fréquences radio (RF)

La puissance de sortie émise par l'appareil de sans fil est inférieure à la limite d'exposition aux fréquences radio d'Industry Canada (IC). Utilisez l'appareil de sans fil de façon à minimiser les contacts humains lors du fonctionnement normal.

Ce périphérique a également été évalué et démontré conforme aux limites d'exposition aux RF d'IC dans des conditions d'exposition à des appareils mobiles (les antennes se situent à moins de 20cm du corps d'une personne).

6 Document Information

6.1 Revision History

New document: "Cinterion® PLS62-W Hardware Interface Overview" Version 00.080

Chapter	What is new
--	Initial document setup.

6.2 Related Documents

- [1] PLS62-W AT Command Set
- [2] PLS62-W Release Note
- [3] Application Note 48: SMT Module Integration
- [4] Application Note 40: Thermal Solutions
- [5] Universal Serial Bus Specification Revision 2.0, April 27, 2000

6.3 Terms and Abbreviations

Abbreviation	Description
ADC	Analog-to-digital converter
AGC	Automatic Gain Control
ANSI	American National Standards Institute
ARFCN	Absolute Radio Frequency Channel Number
ARP	Antenna Reference Point
ASC0/ASC1	Asynchronous Controller. Abbreviations used for first and second serial interface of PLS62-W
B	Thermistor Constant
BER	Bit Error Rate
BIP	Bearer Independent Protocol
BTS	Base Transceiver Station
CB or CBM	Cell Broadcast Message
CE	Conformité Européene (European Conformity)
CHAP	Challenge Handshake Authentication Protocol
CPU	Central Processing Unit
CS	Coding Scheme
CSD	Circuit Switched Data
CTS	Clear to Send
DAC	Digital-to-Analog Converter

6.3 Terms and Abbreviations







Abbreviation	Description
dBm0	Digital level, 3.14dBm0 corresponds to full scale, see ITU G.711, A-law
DCE	Data Communication Equipment (typically modems, e.g. Gemalto M2M module)
DRX	Discontinuous Reception
DSB	Development Support Box
DSP	Digital Signal Processor
DSR	Data Set Ready
DTR	Data Terminal Ready
DTX	Discontinuous Transmission
EFR	Enhanced Full Rate
EIRP	Equivalent Isotropic Radiated Power
EMC	Electromagnetic Compatibility
ERP	Effective Radiated Power
ESD	Electrostatic Discharge
ETS	European Telecommunication Standard
ETSI	European Telecommunication Standards Institute
FCC	Federal Communications Commission (U.S.)
FDMA	Frequency Division Multiple Access
FR	Full Rate
GMSK	Gaussian Minimum Shift Keying
GPIO	General Purpose Input/Output
HiZ	High Impedance
HR	Half Rate
I/O	Input/Output
IC	Integrated Circuit
IMEI	International Mobile Equipment Identity
ISO	International Standards Organization
ITU	International Telecommunications Union
kbps	kbits per second
LED	Light Emitting Diode
Li-Ion/Li+	Lithium-Ion
Li battery	Rechargeable Lithium Ion or Lithium Polymer battery
LPM	Link Power Management
Mbps	Mbits per second
MMI	Man Machine Interface
MO	Mobile Originated
MS	Mobile Station (module), also referred to as TE
MSISDN	Mobile Station International ISDN number

6.3 Terms and Abbreviations

Abbreviation	Description
MT	Mobile Terminated
NTC	Negative Temperature Coefficient
PA	Power Amplifier
PAP	Password Authentication Protocol
PBCCH	Packet Switched Broadcast Control Channel
PCL	Power Control Level
PDU	Protocol Data Unit
PLL	Phase Locked Loop
PSK	Phase Shift Keying
PSU	Power Supply Unit
PWM	Pulse Width Modulation
R&TTE	Radio and Telecommunication Terminal Equipment
RF	Radio Frequency
RLS	Radio Link Stability
RMS	Root Mean Square (value)
RoHS	Restriction of the use of certain hazardous substances in electrical and electronic equipment.
ROM	Read-only Memory
RTC	Real Time Clock
RTS	Request to Send
Rx	Receive Direction
SAR	Specific Absorption Rate
SAW	Surface Accoustic Wave
SELV	Safety Extra Low Voltage
SIM	Subscriber Identification Module
SMD	Surface Mount Device
SMS	Short Message Service
SMT	Surface Mount Technology
SPI	Serial Peripheral Interface
SRAM	Static Random Access Memory
TA	Terminal adapter (e.g. module)
TDMA	Time Division Multiple Access
TE	Terminal Equipment, also referred to as DTE
TLS	Transport Layer Security
Tx	Transmit Direction
UART	Universal asynchronous receiver-transmitter
URC	Unsolicited Result Code
USSD	Unstructured Supplementary Service Data

6.4 Safety Precaution Notes

The following safety precautions must be observed during all phases of the operation, usage, service or repair of any cellular terminal or mobile incorporating PLS62-W. Manufacturers of the cellular terminal are advised to convey the following safety information to users and operating personnel and to incorporate these guidelines into all manuals supplied with the product. Failure to comply with these precautions violates safety standards of design, manufacture and intended use of the product. Gemalto M2M assumes no liability for customer's failure to comply with these precautions.

	<p>When in a hospital or other health care facility, observe the restrictions on the use of mobiles. Switch the cellular terminal or mobile off, if instructed to do so by the guidelines posted in sensitive areas. Medical equipment may be sensitive to RF energy. The operation of cardiac pacemakers, other implanted medical equipment and hearing aids can be affected by interference from cellular terminals or mobiles placed close to the device. If in doubt about potential danger, contact the physician or the manufacturer of the device to verify that the equipment is properly shielded. Pacemaker patients are advised to keep their hand-held mobile away from the pacemaker, while it is on.</p>
	<p>Switch off the cellular terminal or mobile before boarding an aircraft. Make sure it cannot be switched on inadvertently. The operation of wireless appliances in an aircraft is forbidden to prevent interference with communications systems. Failure to observe these instructions may lead to the suspension or denial of cellular services to the offender, legal action, or both.</p>
	<p>Do not operate the cellular terminal or mobile in the presence of flammable gases or fumes. Switch off the cellular terminal when you are near petrol stations, fuel depots, chemical plants or where blasting operations are in progress. Operation of any electrical equipment in potentially explosive atmospheres can constitute a safety hazard.</p>
	<p>Your cellular terminal or mobile receives and transmits radio frequency energy while switched on. Remember that interference can occur if it is used close to TV sets, radios, computers or inadequately shielded equipment. Follow any special regulations and always switch off the cellular terminal or mobile wherever forbidden, or when you suspect that it may cause interference or danger.</p>
	<p>Road safety comes first! Do not use a hand-held cellular terminal or mobile when driving a vehicle, unless it is securely mounted in a holder for speakerphone operation. Before making a call with a hand-held terminal or mobile, park the vehicle. Speakerphones must be installed by qualified personnel. Faulty installation or operation can constitute a safety hazard.</p>
	<p>IMPORTANT! Cellular terminals or mobiles operate using radio signals and cellular networks. Because of this, connection cannot be guaranteed at all times under all conditions. Therefore, you should never rely solely upon any wireless device for essential communications, for example emergency calls. Remember, in order to make or receive calls, the cellular terminal or mobile must be switched on and in a service area with adequate cellular signal strength. Some networks do not allow for emergency calls if certain network services or phone features are in use (e.g. lock functions, fixed dialing etc.). You may need to deactivate those features before you can make an emergency call. Some networks require that a valid SIM card be properly inserted in the cellular terminal or mobile.</p>

7 Appendix

7.1 List of Parts and Accessories

Table 11: List of parts and accessories

Description	Supplier	Ordering information
PLS62-W	Gemalto M2M	Standard module Gemalto M2M IMEI: Packaging unit (ordering) number: L30960-N4600-A100 Module label number: S30960-S4600-A100-1 ¹
PLS62-W Evaluation Module	Gemalto M2M	Ordering number: L30960-N4601-A100 (PLS62-W)
DSB75 Evaluation Kit	Gemalto M2M	Ordering number: L36880-N8811-A100
DSB Mini Compact Evaluation Board	Gemalto M2M	Ordering number: L30960-N0030-A100
Starter Kit B80	Gemalto M2M	Ordering Number L30960-N0040-A100
Multi-Adapter R1 for mounting PLS62-W evaluation modules onto DSB75	Gemalto M2M	Ordering number: L30960-N0010-A100
Approval adapter for mounting PLS62-W evaluation modules onto DSB75	Gemalto M2M	Ordering number: L30960-N2301-A100
SIM card holder incl. push button ejector and slide-in tray	Molex	Ordering numbers: 91228 91236 Sales contacts are listed in Table 12 .

1. Note: At the discretion of Gemalto M2M, module label information can either be laser engraved on the module's shielding or be printed on a label adhered to the module's shielding.

7.1 List of Parts and Accessories

Table 12: Molex sales contacts (subject to change)

Molex For further information please click: http://www.molex.com	Molex Deutschland GmbH Otto-Hahn-Str. 1b 69190 Walldorf Germany Phone: +49-6227-3091-0 Fax: +49-6227-3091-8100 Email: mxgermany@molex.com	American Headquarters Lisle, Illinois 60532 U.S.A. Phone: +1-800-78MOLEX Fax: +1-630-969-1352
Molex China Distributors Beijing, Room 1311, Tower B, COFCO Plaza No. 8, Jian Guo Men Nei Street, 100005 Beijing P.R. China Phone: +86-10-6526-9628 Fax: +86-10-6526-9730	Molex Singapore Pte. Ltd. 110, International Road Jurong Town, Singapore 629174 Phone: +65-6-268-6868 Fax: +65-6-265-6044	Molex Japan Co. Ltd. 1-5-4 Fukami-Higashi, Yamato-City, Kanagawa, 242-8585 Japan Phone: +81-46-265-2325 Fax: +81-46-265-2365

About Gemalto

Since 1996, Gemalto has been pioneering groundbreaking M2M and IoT products that keep our customers on the leading edge of innovation.

We work closely with global mobile network operators to ensure that Cinterion[®] modules evolve in sync with wireless networks, providing a seamless migration path to protect your IoT technology investment.

Cinterion products integrate seamlessly with Gemalto identity modules, security solutions and licensing and monetization solutions, to streamline development timelines and provide cost efficiencies that improve the bottom line.

As an experienced software provider, we help customers manage connectivity, security and quality of service for the long lifecycle of IoT solutions.

For more information please visit

www.gemalto.com/m2m, www.facebook.com/gemalto, or [Follow@gemaltoIoT](https://twitter.com/Follow@gemaltoIoT) on Twitter.

Gemalto M2M GmbH
Werinherstrasse 81
81541 Munich
Germany

➔ GEMALTO.COM/M2M

gemalto
security to be free