



Owner's Manual and Installation Instructions

**Air-cooled Recreational
Vehicle Generators**

• Model: 004701-0
QUIETPACT 40LP



This manual should remain with the unit.

INTRODUCTION

Thank you for purchasing this model by Generac Power Systems Inc. It has been designed and manufactured to supply electrical power for recreational vehicles.

◆ READ THIS MANUAL THOROUGHLY

If any portion of this manual is not understood, contact the nearest Authorized Service Dealer for starting, operating and servicing procedures.

Throughout this publication, and on tags and decals affixed to the generator, DANGER, WARNING, CAUTION and NOTE blocks are used to alert personnel to special instructions about a particular operation that may be hazardous if performed incorrectly or carelessly. Observe them carefully. Their definitions are as follows:



After this heading, read instructions that, if not strictly complied with, will result in personal injury or property damage.



After this heading, read instructions that, if not strictly complied with, may result in personal injury or property damage.



After this heading, read instructions that, if not strictly complied with, could result in damage to equipment and/or property.

NOTE:

After this heading, read explanatory statements that require special emphasis.

These safety warnings cannot eliminate the hazards that they indicate. Common sense and strict compliance with the special instructions while performing the service are essential to preventing accidents.

Four commonly used safety symbols accompany the DANGER, WARNING and CAUTION blocks. The type of information each indicates follows:

 This symbol points out important safety information that, if not followed, could endanger personal safety and/or property of others.

 This symbol points out potential explosion hazard.

 This symbol points out potential fire hazard.

 This symbol points out potential electrical shock hazard.

The operator (driver) is responsible for proper and safe use of the vehicle and its equipment, and the safety of all vehicle occupants. We strongly recommend that the operator read this manual and thoroughly understand all instructions before using this equipment. We also strongly recommend instructing other occupants in the vehicle to properly start and operate the generator. This prepares them if they need to operate the equipment in an emergency.

◆ CONTENTS

This manual contains pertinent owner's information, including warranty, electrical diagrams, exploded views and lists of repair parts for generator model numbers 004701-0. In addition, the latter portion of this manual contains information necessary for the proper installation of these generators.

◆ OPERATION AND MAINTENANCE

It is the operator's responsibility to perform all safety checks, to make sure that all maintenance for safe operation is performed promptly, and to have the equipment checked periodically by an Authorized Service Dealer. Normal maintenance service and replacement of parts are the responsibility of the owner/operator and, as such, are not considered defects in materials or workmanship within the terms of the warranty. Individual operating habits and usage contribute to the need for maintenance service.

Proper maintenance and care of the generator ensures a minimum number of problems and keep operating expenses at a minimum. See the Authorized Service Dealer for service aids and accessories.

◆ HOW TO OBTAIN SERVICE

When the generator requires servicing or repairs, simply contact an Authorized Service Dealer for assistance. Service technicians are factory-trained and are capable of handling all service needs.

When contacting an Authorized Service Dealer about parts and service, always supply the complete model number and serial number of the unit as given on its data label, which is located on the generator.

Model No. _____ Serial No. _____

AUTHORIZED SERVICE DEALER LOCATION

To locate the nearest AUTHORIZED SERVICE
DEALER, please call this number:

1-800-333-1322

or locate us on the web at

www.guardiangenerators.com

Part I – Owner’s Manual

Part II – Installation Instructions

Introduction	Inside Front Cover
Read This Manual Thoroughly.....	IFC
Contents	IFC
Operation and Maintenance.....	IFC
How to Obtain Service	IFC
Authorized Service Dealer Locator Number	IFC
Safety Rules	2
Section 1 – General Information	4
1.1 Generator Identification.....	4
1.2 Generator Applicability.....	5
1.3 Safety.....	5
1.4 Generator AC Connection System.....	5
1.5 Specifications.....	5
Section 2 – Operation	6
2.1 Generator Control Panel.....	6
2.2 Optional Remote Start/Stop Panel	7
2.3 Before Starting the Engine.....	7
2.4 Starting the Generator	7
2.5 Stopping the Generator	8
2.6 Applying Loads to Generator	8
2.7 Do Not Overload the Generator	8
2.8 Protection Systems	8
2.9 Additional Information	9
Section 3 – Maintenance.....	10
3.1 Checking the Engine Oil Level	10
3.2 Changing the Engine Oil and/or Oil Filter	11
3.3 Maintaining the Engine Air Cleaner	11
3.4 Clean Air Intake.....	12
3.5 Checking the Engine Spark Plug.....	12
3.6 Clean Spark Arrestor.....	12
3.7 Cleaning the Generator.....	13
3.8 Battery Maintenance	13
3.9 Major Service Manual	14
3.10 Exercising the Generator	14
3.11 Out of Service Procedure	14
3.12 Adjusting Valve Clearance.....	14
3.13 RV Generator Service Interval	15
Section 4 – Notes	16

Safety Rules	18
Section 1 – General Information	20
1.1 Purpose and Scope of the Manual	20
1.2 Safety.....	20
1.3 Standards Booklets	20
1.4 Equipment Description.....	20
1.5 Generator Engine Operating Speed	20
1.6 Generator AC Connection System.....	20
Section 2 – Installation	22
2.1 Location and Support.....	22
2.2 Generator Compartments	23
2.3 Cooling and Ventilating Air	26
2.4 LP Gas Fuel System.....	26
2.5 Exhaust System.....	28
2.6 Electrical Connections	29
2.7 Battery Installation... ..	32
2.8 Optional Accessories.....	32
Section 3 – Post-installation Start-up Adjustments.....	33
3.1 Post Installation Tests.....	33
3.2 Before Initial Start-up	33
3.3 Initial Start	33
3.4 Testing Under Load	34
3.5 Installation Checklist	35
Section 4 – Troubleshooting.....	36
Section 5 – Notes	37
Section 6 – Electrical Data	38
Section 7 – Exploded Views and Parts Lists.....	40
Section 8 – Warranty	52



⚠ SAVE THESE INSTRUCTIONS – The manufacturer suggests that these rules for safe operation be copied and posted near the unit's installation site. Safety should be stressed to all operators and potential operators of this equipment. ⚠

**WARNING:**

The engine exhaust from this product contains chemicals known to the state of California to cause cancer, birth defects or other reproductive harm.

**WARNING:**

This product contains or emits chemicals known to the state of California to cause cancer, birth defects or other reproductive harm.

Study these SAFETY RULES carefully before installing, operating or servicing this equipment. Become familiar with this *Owner's Manual* and with the unit. The generator can operate safely, efficiently and reliably only if it is properly installed, operated and maintained. Many accidents are caused by failing to follow simple and fundamental rules or precautions.

The manufacturer cannot anticipate every possible circumstance that might involve a hazard. The warnings in this manual, and on tags and decals affixed to the unit are, therefore, not all-inclusive. If using a procedure, work method or operating technique the manufacturer does not specifically recommend, ensure that it is safe for others. Also make sure the procedure, work method or operating technique utilized does not render the generator unsafe.

— **⚠ DANGER ⚠** —

⚠ Despite the safe design of this generator, operating this equipment imprudently, neglecting its maintenance or being careless can cause possible injury or death. Permit only responsible and capable persons to operate or maintain this equipment.

⚠ Potentially lethal voltages are generated by these machines. Ensure all steps are taken to render the machine safe before attempting to work on the generator.

⚠ Parts of the generator are rotating and/or hot during operation. Exercise care near running generators.

⚠ GENERAL HAZARDS ⚠

- For safety reasons, the manufacturer recommends that the installation, initial start-up and maintenance of this equipment is carried out by an Authorized Service Dealer.
- The generator engine releases DEADLY carbon monoxide gas through its exhaust system. This dangerous gas, if breathed in sufficient concentrations, can cause unconsciousness or even death. Never operate the generator set with the vehicle inside any garage or other enclosed area. **DO NOT OPERATE THE GENERATOR IF THE EXHAUST SYSTEM IS LEAKING OR HAS BEEN DAMAGED. SYMPTOMS OF CARBON MONOXIDE POISONING ARE (a) inability to think coherently, (b) nausea, (c) vomiting, (d) twitching muscles, (e) throbbing temples, (f) dizziness, (g) headaches, (h) weakness, and (i) sleepiness. IF EXPERIENCING ANY OF THESE SYMPTOMS, MOVE INTO FRESH AIR IMMEDIATELY. IF SYMPTOMS PERSIST, GET MEDICAL HELP.** Shut down the generator and do not operate it until it has been inspected and repaired.
- Never sleep in the vehicle while the genset is running unless the vehicle has a working carbon monoxide detector. The exhaust system must be installed in accordance with the genset installation manual. Make sure there is ample fresh air when operating the genset in a confined area.
- The engine exhaust fumes contain carbon monoxide, which can be DEADLY. This dangerous gas, if breathed in sufficient concentrations, can cause unconsciousness or even death. This exhaust system must be installed properly, in strict compliance with applicable codes and standards. Following installation, do nothing that might render the system unsafe or in noncompliance with such codes and standards. The generator compartment must be completely vapor sealed from the vehicle interior. There must be no possibility of exhaust fumes entering the vehicle interior. Never operate this equipment with a leaking or defective exhaust system.
- Keep hands, feet, clothing, etc., away from drive belts, fans, and other moving or hot parts. Never remove any drive belt or fan guard while the unit is operating.



- Adequate, unobstructed flow of cooling and ventilating air is critical to correct generator operation and is required to expel toxic fumes and fuel vapors from the generator compartment. Without sufficient cooling airflow, the engine/generator quickly overheats, which causes serious damage to the generator. Do not alter the installation or permit even partial blockage of ventilation provisions, as this can seriously affect safe operation of the generator.
- When working on this equipment, remain alert at all times. Never work on the equipment when physically or mentally fatigued.
- Inspect the generator regularly, and contact the nearest Authorized Service Dealer immediately for parts needing repair or replacement.
- Before performing any maintenance on the generator, disconnect its battery cables to prevent accidental start up. Disconnect the cable from the battery post indicated by a NEGATIVE, NEG or (-) first. Reconnect that cable last.
- Never use the generator or any of its parts as a step. Stepping on the unit can stress and break parts, and may result in dangerous operating conditions from leaking exhaust gases, fuel leakage, oil leakage, etc.
- In case of accident caused by electric shock, immediately shut down the source of electrical power. If this is not possible, attempt to free the victim from the live conductor. AVOID DIRECT CONTACT WITH THE VICTIM. Use a nonconducting implement, such as a rope or board, to free the victim from the live conductor. If the victim is unconscious, apply first aid and get immediate medical help.
- Never wear jewelry when working on this equipment. Jewelry can conduct electricity resulting in electric shock, or may get caught in moving components causing injury.

FIRE HAZARDS

- For fire safety, the generator must be installed and maintained properly. Installation always must comply with applicable codes, standards, laws and regulations. Adhere strictly to local, state and national electrical and building codes. Comply with regulations the Occupational Safety and Health Administration (OSHA) has established. Also, ensure that the generator is installed in accordance with the manufacturer's instructions and recommendations. Following proper installation, do nothing that might alter a safe installation and render the unit in noncompliance with the aforementioned codes, standards, laws and regulations.
- Keep a fire extinguisher in the vehicle at all times. Extinguishers rated "ABC" by the National Fire Protection Association are appropriate for use on the recreational vehicle generator electrical system. Keep the extinguisher properly charged and be familiar with its use. If there are any questions pertaining to fire extinguishers, consult the local fire department.

ELECTRICAL HAZARDS

- The generator covered by this manual produces dangerous electrical voltages and can cause fatal electrical shock. Avoid contact with bare wires, terminals, connections, etc., while the unit is running. Ensure all appropriate covers, guards and barriers are in place before operating the generator. If work must be done around an operating unit, stand on an insulated, dry surface to reduce shock hazard.
- Do not handle any kind of electrical device while standing in water, while barefoot, or while hands or feet are wet. DANGEROUS ELECTRICAL SHOCK MAY RESULT.
- During installation onto the vehicle, have the generator properly grounded (bonded) either by solid mounting to the vehicle frame or chassis, or by means of an approved bonding conductor. DO NOT disconnect the bonding conductor, if so equipped. DO NOT reconnect the bonding conductor to any generator part that might be removed or disassembled during routine maintenance. If the grounding conductor must be replaced, use only a flexible conductor that is of No. 8 American Wire Gauge (AWG) copper wire minimum.

EXPLOSION HAZARDS

- Do not smoke around the generator. Wipe up any fuel or oil spills immediately. Ensure that no combustible materials are left in the generator compartment, or on or near the generator, as FIRE or EXPLOSION may result. Keep the area surrounding the generator clean and free from debris.
- Gasoline is extremely FLAMMABLE and its vapors are EXPLOSIVE. Do not permit smoking, open flame, sparks or any source of heat in the vicinity while handling gasoline. Comply with all laws governing the storage and handling of gasoline.

1.1 GENERATOR IDENTIFICATION

Please record the following information from the generator DATA LABEL or information decal.

- | | |
|-----------------------|------------------------|
| 1. Model Number _____ | 2. Serial Number _____ |
| 3. kW Rating _____ | 4. Rated Voltage _____ |

- | | |
|---|--------------------------------------|
| 1. Generator Air Intake | 10. Fuel Pump (Behind Access Panel) |
| 2. Engine Start/Stop Switch | 11. LP Regulator/Solenoid |
| 3. Fuse | 12. Oil Filter |
| 4. Optional Remote Panel Receptacle (Side View) | 13. Oil Drain Cap |
| 5. Generator AC Output Leads (Side View) | 14. Oil Dipstick |
| 6. Fuel Primer Switch | 15. Air Filter (Behind Access Panel) |
| 7. Circuit Breaker | 16. Oil Fill |
| 8. Starter Contactor | 17. Spark Plug |
| 9. Fuel Inlet | |

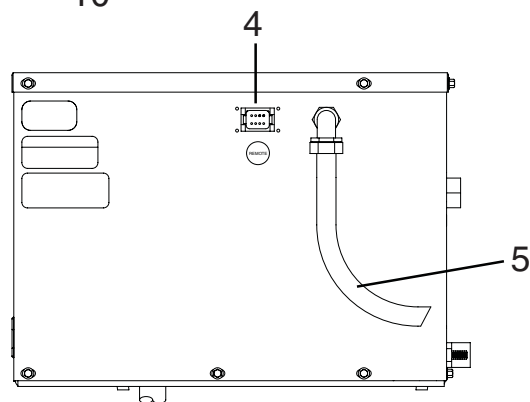
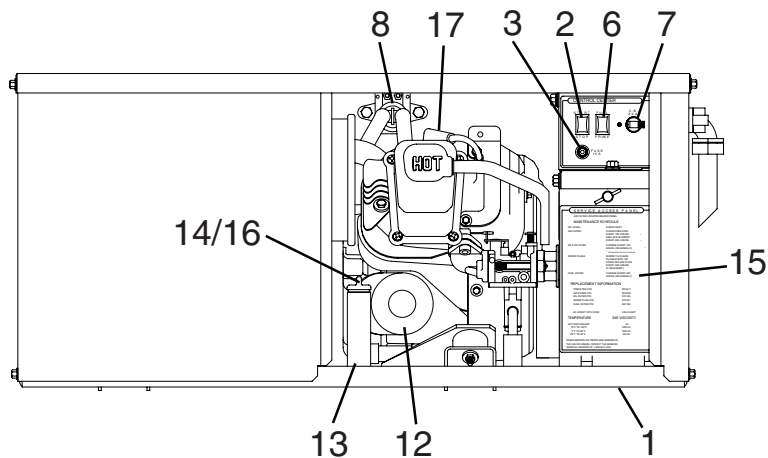
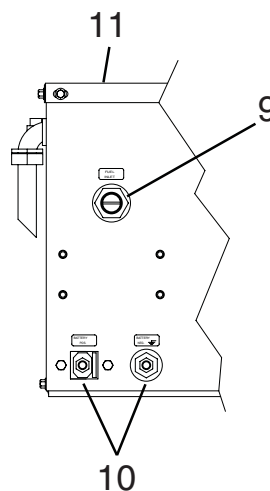

1.2 GENERATOR APPLICABILITY

These generators have been designed and manufactured for supplying electrical power for recreational vehicles. Do not modify the generator or use it for any application other than for what it was designed. If there are any questions pertaining to its application, write or call the factory. Do not use the unit until advised by a competent authority.



 For fire safety, the generator must have been properly installed in compliance with ANSI 119.2-1975/NFPA 501C-1974, “Standard for Recreational Vehicles, Part III – Installation of Electrical Systems.” The generator also must have been installed in strict compliance with the manufacturer’s detailed installation instructions. After installation, do nothing that might render the unit in noncompliance with such codes, standards and instructions.

Use this generator to supply electrical power for operating 120-volt, single-phase, 60 Hertz, AC electrical loads. These loads can require up to 3,400 watts (3.4 kW) of power, but cannot exceed 28.3 AC amperes of current at 120 volts.



 Do not overload the generator. Some installations may require that electrical loads be alternated to avoid overloading. Applying excessively high electrical loads may damage the generator and may shorten its life. Add up the rated watts of all electrical lighting, appliance, tool and motor loads the generator will power at one time. This total should not be greater than the wattage capacity of the generator. If an electrical device nameplate gives only volts and amps, multiply volts times amps to obtain watts (volts x amps = watts). Some electric motors require more watts of power (or amps of current) for starting than for continuous operation.

1.3 SAFETY

Before attempting to use the generator set, carefully read the “Safety Rules” section of this manual. Comply strictly with these rules to prevent accidents and damage to equipment and/or property. We suggest copying and posting the “Safety Rules” in potential hazard areas of the vehicle. Stress safety to all operators and potential operators of this equipment.

1.4 GENERATOR AC CONNECTION SYSTEM

This generator set is equipped with dual stator AC power windings. These two-stator windings supply electrical power to customer electrical loads by means of a two-wire connection system. Note, however, that the neutral is bonded to the frame of the engine-generator.

The generator may have been installed so that it powers 120-volt AC loads (Figure 1.1).

Figure 1.1 – Connections for 120 Volts Only

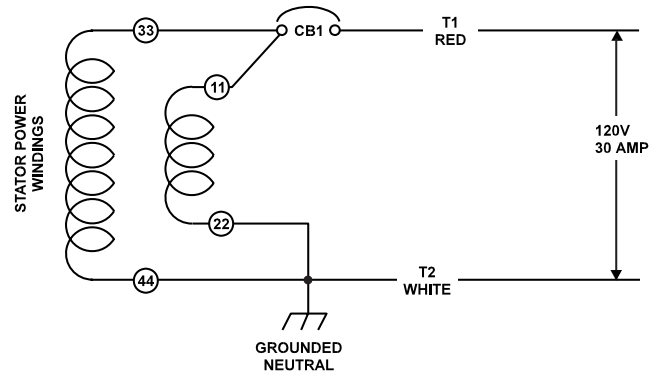

1.5 SPECIFICATIONS

◆ 1.5.1 FUEL REQUIREMENTS

These generators are equipped with a liquefied petroleum (LP) gas fuel system. LP gas is usually supplied as a liquid in pressure tanks.

These generators require a “vapor withdrawal” type fuel system. This type of gaseous fuel system uses the vapors forming above the liquid fuel in the storage tank. Air temperature around the storage tank must be high enough to sustain adequate fuel vaporization. In colder climates, use of an independent heat source may be needed to be sure the fuel sufficiently vaporizes in the storage tank.

LP gas may consist of propane, butane, or a mixture of the two gases. Propane vaporizes at temperatures as low as -20°F (-29°C), but butane returns to its liquid state when the temperature drops below about 32°F (0°C). For that reason, a higher ratio of propane is desired in the gas mixture when temperatures drop below freezing.

◆ 1.5.2 FUEL CONSUMPTION

Model	1/2 Load	Full Load
004701-0	0.55	0.73

Fuel consumption is in gal/hr.

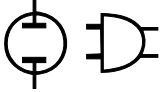

◆ 1.5.3 ENGINE OIL REQUIREMENTS

Use only high quality detergent oil rated with American Petroleum Institute (API) Service Classification SF, SG or SH. The recommended oil weights include the following:

- During summer months: SAE 30. An acceptable substitute is SAE 10W-30.
- During winter months: SAE 5W-30. DO NOT USE SAE 10-W40.

Crankcase and oil filter capacity is approximately 800 mL or .84 U.S. quarts. Do NOT use special additives. See "Checking the Engine Oil Level" and "Changing the Engine Oil and/or Oil Filter" sections for oil level check and fill procedures.

◆ 1.5.4 ENGINE

Type of Engine.....	GN-220, Single-cylinder
Cooling Method	Air-cooled
Rated Horsepower	7.8 @ 4,200 rpm
Displacement.....	220cc
Cylinder Block	Aluminum w/Cast Iron Sleeve
Type of Governor	Mechanical, Fixed Speed
Air Cleaner	Paper Element w/Foam Precleaner
Starter	12-volt DC Electric
Ignition System	Solid-state w/Flywheel Magneto
Recommended Spark Plug	
Champion	RC14YC
AC.....	R45S
Fram Autolite	65
Spark Plug Gap.....	0.030 inch (76 mm)
Recommended Minimum Battery.....	400 Cold-cranking Amperes

◆ 1.5.5 GENERATOR

Rated Maximum Continuous	
AC Output (Gasoline).....	3,400 Watts (3.4 kW)
Rated Voltage.....	120 Volts AC
Rated Maximum Continuous	
AC Current (Gasoline)	28.3 Amperes
Phase	Single
Rotor RPM.....	3,600
Number of Rotor Poles.....	2
Engine RPM.....	3,600
Rated AC Frequency.....	60 Hz
Battery Charge Voltage	14 Volts DC
Battery Charge Current.....	2 Amperes (max)
Gasoline weight.....	170 Pounds
Length.....	749.8 mm (29.52 in.)
Width.....	483.1 mm (19.02 in.)
Height	342.2 mm (13.47 in.)

* Maximum wattage and current are subject to, and limited by, such factors as fuel Btu content, ambient temperature, altitude, engine condition, etc.. Maximum power decreases about 3.5% for each 1,000 feet above sea level; and will also decrease about 1% for each 6° C (10° F) above 16° C (60° F) ambient temperature.

◆ 1.5.6 EMISSIONS COMPLIANCE PERIOD

For non-handheld engines the Emissions Compliance Period referred to on the Emissions Compliance Label indicates the number of operating hours for which the engine has been shown to meet Federal emission requirements.

- For engines less than 225 cc displacement, Category C=125 hours, B=250 hours, and A=500 hours.
- For engines of 225 cc or more, Category C=250 hours, B=500 hours, and A=1000 hours.

2.1 GENERATOR CONTROL PANEL

The following features are mounted on the generator control panel (Figure 2.1):

Figure 2.1 – Generator Control Panel

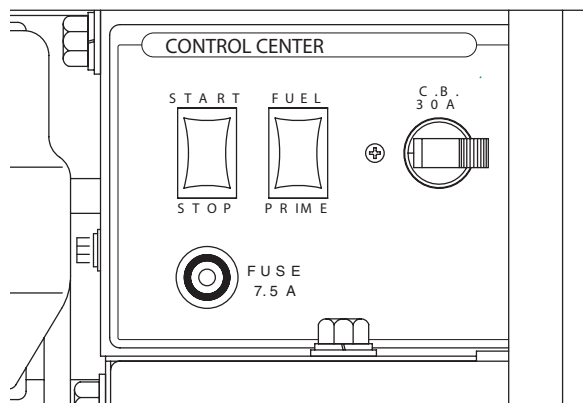

◆ 2.1.1 FUEL PRIMER

Before starting a cold engine (if it has not been started in more than two weeks), press this switch for approximately 10 to 15 seconds to bring fuel from the tank to the carburetor. This rocker type switch springs back into its original position when released.

◆ 2.1.2 START/STOP SWITCH

To crank and start the engine, hold this switch in the START position. Release the switch when the engine starts. To stop an operating engine, press and hold the switch in the STOP position until the engine shuts off. The switch center position is the RUN position.

◆ 2.1.3 FUSE

The fuse protects the engine's DC control circuit against electrical overload. If the fuse element has melted open due to overloading, the engine cannot be cranked. If the fuse must be replaced, use only an identical replacement.

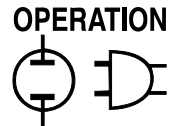

◆ 2.1.4 MAIN BREAKER

The main breaker protects the generator's AC output circuit against overload and provides a method of turning OFF the generator's 120-volt AC output to the vehicle circuits. This generator has a 30-amp breaker.

2.2 OPTIONAL REMOTE START/STOP PANEL

A remote mounted Start/Stop Panel is available that allows starting and stopping the generator engine conveniently from inside the vehicle.

Order part number 0F0429 or 0F0430, a remote panel that includes a Start/Stop switch, a generator run lamp, a fuel prime switch, and an hourmeter. The hourmeter provides a continuous indication of engine/generator operating time. Use the hourmeter for checking off periodic maintenance requirements on the unit.

2.3 BEFORE STARTING THE ENGINE

NOTE:

Instructions and information in this manual assume the generator has been properly installed, connected, serviced, tested and adjusted by a qualified installation technician or installation contractor.

◆ 2.3.1 INSTALLATION

Generator installation must have been properly completed so it complies with all applicable codes, standards and regulations and with the manufacturer's recommendations.

◆ 2.3.2 ENGINE LUBRICATION

Have the engine crankcase properly serviced with the recommended oil before starting. Refer to the "Specifications", "Checking the Engine Oil Level", and "Changing the Engine Oil and/or Oil Filter" sections for oil servicing procedures and recommendations.



⚠ Any attempt to crank or start the engine before it has been properly serviced with the recommended oil may result in an engine failure.

◆ 2.3.3 FUEL SUPPLY

The engine must have an adequate supply of proper fuel to operate. Before starting it, check that sufficient fuel is available.

◆ 2.3.4 COOLING AND VENTILATING AIR

Air inlet and outlet openings in the generator compartment must be open and unobstructed for continued proper operation. Without sufficient cooling and ventilating airflow, the engine/generator quickly overheats, which causes it to shut down and may damage the generator.

◆ 2.3.5 ENGINE EXHAUST GAS

Before starting the generator engine, be sure there is no way for exhaust gases to enter the vehicle interior and endanger people or animals. Close windows, doors and other openings in the vehicle that, if open, might permit exhaust gases to enter the vehicle.



⚠ The generator engine releases **DEADLY** carbon monoxide gas through its exhaust system. This dangerous gas, if breathed in sufficient concentrations, can cause unconsciousness or even death. Never operate the generator set with the vehicle inside any garage or other enclosed area. **DO NOT OPERATE THE GENERATOR IF THE EXHAUST SYSTEM IS LEAKING OR HAS BEEN DAMAGED. SYMPTOMS OF CARBON MONOXIDE POISONING ARE (a) inability to think coherently, (b) nausea, (c) vomiting, (d) twitching muscles, (e) throbbing temples, (f) dizziness, (g) headaches, (h) weakness, and (i) sleepiness. IF EXPERIENCING ANY OF THESE SYMPTOMS, MOVE INTO FRESH AIR IMMEDIATELY. IF SYMPTOMS PERSIST, GET MEDICAL HELP.** Shut down the generator and do not operate it until it has been inspected and repaired.



⚠ Never sleep in the vehicle while the genset is running unless the vehicle has a working carbon monoxide detector. The exhaust system must be installed in accordance with the genset installation manual. Make sure there is ample fresh air when operating the genset in a confined area.

2.4 STARTING THE GENERATOR

NOTE:

Read the vehicle manufacturer's instructions. The owner/operator should become familiar with the vehicle in which this generator is installed. Differences exist between vehicles. For example, some vehicles may use a transfer switch to isolate dockside power from the generator, while other vehicles may use an isolating receptacle. Some vehicles may be equipped with a DC converter, which allows the generator to power certain DC lighting and other DC loads.

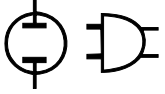

To start the generator from either the generator control panel or from the optional remote panel, proceed as follows:

1. Turn OFF electrical loads using the means provided in the vehicle (such as a main line circuit breaker or transfer switch).

NOTE:

If starting from the generator control panel, turn OFF loads by setting the generator's main circuit breaker to the OFF (or open) position. If starting from a remote panel, turn OFF loads using the means provided in the vehicle (such as a main circuit breaker). Electrical load circuits will be turned ON after the generator has started, stabilized and warmed up.

2. If the engine has not been started in more than two weeks, press the Fuel Pump Primer switch and hold it for about 10 to 15 seconds to prime the fuel system. However, if the engine is warm, skip Step 2.
3. Hold the engine Start/Stop switch in the START position to crank the engine. Release the switch when the engine starts.



⚠ If the engine does not start after it has been cranking for 15 seconds, release the Start/Stop switch, wait one minute and try again. Holding the switch for longer than 15 seconds can damage the starter motor.

4. Let the engine run at no-load for a few minutes to stabilize and warm up.
5. Turn ON electrical loads using the means provided (such as a main circuit breaker or transfer switch).

2.5 STOPPING THE GENERATOR

1. Turn OFF all electrical loads using the means provided (such as a main circuit breaker or transfer switch).
2. Let generator run at no-load for a few minutes, to stabilize internal engine generator temperatures.
3. Place the Start/Stop switch in its STOP position.

2.6 APPLYING LOADS TO GENERATOR

When applying electrical loads to the generator, observe these guidelines:

- Before applying electrical loads, let the generator stabilize and warm up for a minute or two.
- DO NOT overload the generator.

◆ 2.6.1 LETTING THE ENGINE STABILIZE

The generator supplies correct rated voltage only at the proper governed speed. Some electrical appliances may be extremely sensitive to voltage. Incorrect voltages can damage such appliances.

If electrical loads are applied at reduced operating speeds, such loads imposed on the engine when sufficient power is not available may shorten engine life. Never turn ON electrical loads until after the generator engine has started and stabilized at no-load.

2.7 DO NOT OVERLOAD THE GENERATOR

Read the rated wattage/amperage capacity of the generator on the generator data label (see "Generator Identification").

Applying electrical loads in excess of the unit's rated capacity will cause the engine/generator to automatically shut down.

To avoid overloading, add up the wattage of all connected electrical lighting, appliance, tool and motor loads. This total should not be greater than the generator's rated wattage capacity.

- Most lighting, appliance, tool and motor loads indicate their required watts on their nameplate or data plate. For light bulbs, simply note the wattage rating of the bulb.
- If a load does not show its rated wattage, multiply that load's rated VOLTS times AMPS to obtain WATTS.
- Induction type motors (such as those that run the vehicle's furnace fan, refrigerator, air conditioner, etc.) need about 2-1/2 time more watts of power for starting than for running (for a few seconds during motor starting). Be sure to allow for this when connecting electrical loads to the generator. First, figure the watts needed to start electric motors in the system. To that figure, add the running wattages of other items that will be operated by the generator.
- Do not apply heavy electrical loads for the first two or three hours of operation.

2.8 PROTECTION SYSTEMS

◆ 2.8.1 LOW OIL PRESSURE SWITCH

This switch (Figure 2.2) has normally closed (N.C.) contacts that are held open by engine oil pressure during cranking and operating. Should oil pressure drop below a preset level, switch contacts close, and the engine automatically shuts down. The unit should not be restarted until oil is added.

◆ 2.8.2 HIGH TEMPERATURE SWITCH

This switch (Figure 2.2), which has normally open (N.O.) contacts, is mounted near the oil filter. The contacts close if the temperature should exceed approximately 284° F (140° C), initiating an engine shutdown.

Figure 2.2 – Low Oil Pressure and High Temperature Switches

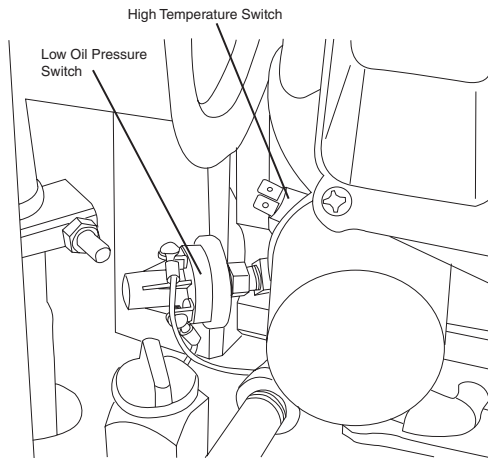

◆ 2.8.3 FIELD BOOST

The Controller Circuit Board houses a field boost diode and resistor that are not part of the automatic choke circuit. These two components are part of a “field boost” circuit (Figure 2.3). During engine cranking only, a positive DC (battery) voltage is delivered through the diode, resistor, brushes and slip rings, to the generator rotor. Application of this voltage to the rotor “flashes the field” whenever it is started. Flashing of the field each time the generator starts makes sure that a sufficiently strong magnetic field is available to produce “pickup” voltage in the stator windings.

Figure 2.3 – Field Boost Circuit

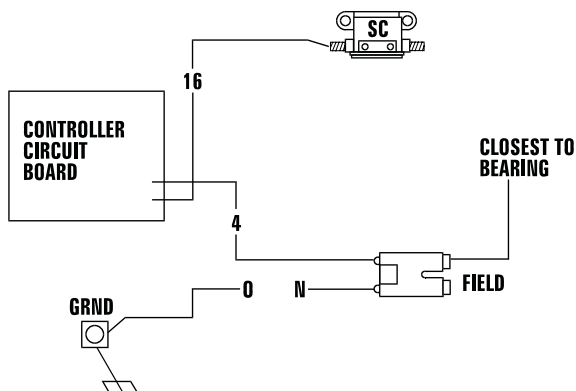

◆ 2.8.4 OVERVOLTAGE PROTECTION

A solid-state voltage regulator (Figure 2.4) controls the generator’s AC output voltage. This regulator supplies an excitation current to the rotor. By regulating the rotor’s excitation current, the strength of its magnetic field is regulated and, in turn, the voltage delivered to connected electrical loads is controlled. When the AC frequency is 60 Hertz, voltage is regulated at 120 volts (voltage-to-frequency ratio is 2-to-1).

Figure 2.4 – Solid State Voltage Regulator

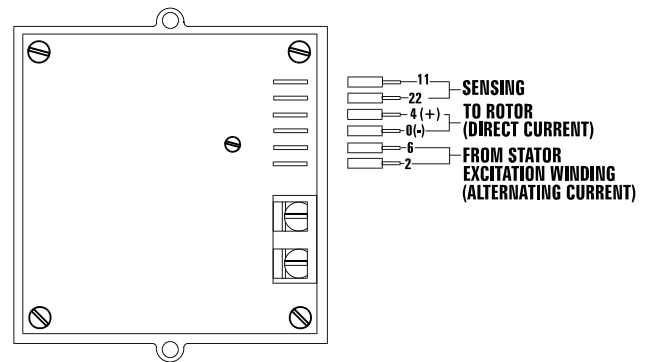

The voltage regulator also incorporates a “voltage surge protection circuit.” This circuit prevents troublesome surges in the generator AC output voltage. Voltage surge is a common cause of damage to electronic equipment.

2.9 ADDITIONAL INFORMATION

◆ 2.9.1 25-HOUR BREAK-IN PERIOD

The first 25 hours of operation is the break-in period for the generator. Properly breaking in the generator is essential to minimize fuel consumption and provide maximum engine performance. During this 25-hour break-in period, follow this procedure:

- Run the unit at varying electrical loads to help seat the engine piston rings properly.
- Check the engine oil level frequently. Add oil if needed. It is normal for the generator engine to consume more oil than is normal until the piston rings have properly seated.
- For the 75-hour operation following the break-in period, avoid light electrical loads. Load the generator at 50 percent (or more) of its rated wattage capacity. Repeated light loads during these 75 hours can cause improper seating of engine piston rings, resulting in blowby and high oil consumption.
- After operating the unit for 25 hours, complete the tasks recommended under "25-Hour Check-up".

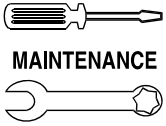

MAINTENANCE

Section 3 – Maintenance

Recreational Vehicle Generator

◆ 2.9.2 25-HOUR CHECK-UP

After the 25-hour break-in period, contact an Authorized Service Dealer for the following maintenance. The vehicle owner is responsible for any charges:

- Change the engine crankcase oil and oil filter.
- Check the oil level.
- Inspect the cooling and ventilation openings.
- Check the engine carburetor adjustments.
- Check the engine ignition system.
- Inspect the entire electrical system.
- Inspect the engine exhaust system.

◆ 2.9.3 ATTENTION REQUIRED AFTER SUBMERSION

If the recreational vehicle generator has been submerged in water, it **MUST NOT** be started and operated. Following any submersion in water, have an Authorized Service Dealer thoroughly clean and dry the generator.

◆ 2.9.4 OPERATION IN HIGH GRASS OR BRUSH

Never operate the generator while the vehicle is parked over high grass, weeds, brush, leaves or any other combustible substance. Such materials can ignite and burn from the heat of the exhaust system. The generator exhaust system becomes extremely hot during operation and remains hot for a long time after it has shut down.

◆ 2.9.5 EFFECTS OF MOISTURE AND DIRT

Keep the generator set as clean and dry as possible. Protect the unit against excessive dust, dirt, corrosive vapors, road splash, etc. Permitting dirt and moisture to accumulate on generator windings will have an adverse effect on the insulation resistance of those windings.

When moisture is allowed to remain in contact with windings, some of the moisture will be retained in voids and cracks in the insulation. This causes a reduced insulation resistance and will eventually cause problems. Dirt will make the problem worse, since dirt tends to hold moisture in contact with windings. Salt (as from sea air) also will worsen the problem since it tends to absorb moisture from the air. Salt and moisture, when combined, form a good electrical conductor.

3.1 CHECKING THE ENGINE OIL LEVEL

For oil capacities and requirements, see “Engine Oil Requirements” section. Check the engine crankcase oil level at least every eight hours of operation, or before using it. To check the engine oil level, proceed as follows (see Figure 3.1):

1. Be sure the generator is as level as possible.
2. Remove the dipstick and wipe it dry with a clean, lint-free cloth.
3. Install and tighten the dipstick cap; then, remove it again. The oil level should be at the dipstick “Full” mark.

Figure 3.1 – Oil Maintenance Features

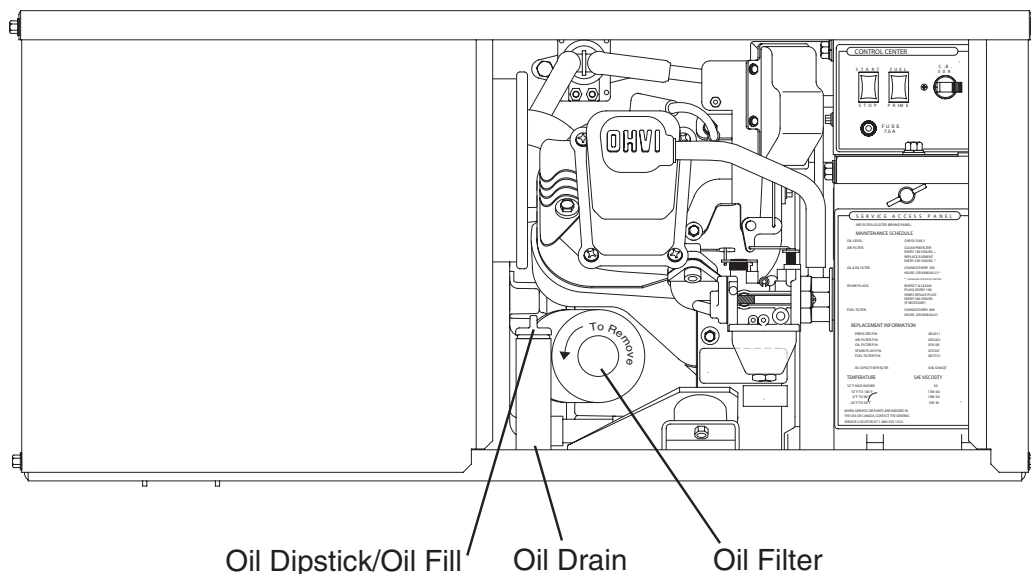

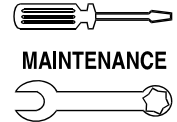

- If necessary, remove the oil fill cap on the rocker cover and slowly add oil until it reaches the dipstick "Full" mark. DO NOT FILL ABOVE THE "FULL" MARK.



⚠ **Never operate the engine with the oil level below the "Add" mark on the dipstick. Doing this could damage the engine.**

- Install and tighten the oil fill cap and the dipstick before operating the engine.

3.2 CHANGING THE ENGINE OIL AND/OR OIL FILTER

- Change the **engine oil** after the first 25 hours of operation (after the 25-hour break-in period section). Thereafter, change the oil every 100 operating hours. Change the oil more frequently if operating consistently under heavy load or at high ambient temperatures.
- Change the engine **oil filter** after the first 25 hours of operation, and every 100 operating hours thereafter.

To change the oil and/or oil filter, proceed as follows (see Figure 3.1):

- Run the engine until it is thoroughly warmed up (at least five minutes) then shut OFF the engine.
- Immediately after the engine shuts OFF, pull the oil drain cover free of the base. Remove the plug from the tube with a 5/16" allen wrench and drain the oil into a suitable container. Loosening the oil fill cap will allow the crankcase to drain faster.
- After the oil has drained, replace the plug onto the end of the oil drain tube. Retain the cover in the base.
- With the oil drained, remove the old oil filter by turning it counterclockwise. Place a towel underneath to catch excess oil.
- Apply a light coating of clean engine oil to the gasket of the new filter. Fill the filter until saturated with clean oil.
- Screw the new filter on by hand until its gasket lightly contacts the oil filter adapter. Then, tighten the filter an additional 3/4 to one turn.
- Remove the dipstick and wipe it dry with a clean, lint-free cloth. This will be used later to check the oil level.
- Remove the oil fill cap on the oil fill tube and slowly add the proper type and amount of recommended oil (see Specifications). Periodically use the dipstick to check the oil level and continue to fill the crankcase until the oil reaches the dipstick "Full" mark. DO NOT FILL ABOVE THE "FULL" MARK.

- Install and tighten the oil fill cap and the dipstick before operating the engine.
- Start the engine and check for leaks.

NOTE:

Check the oil level and fill to the "FULL" mark after checking for leaks. The filter will retain some oil.

3.3 MAINTAINING THE ENGINE AIR CLEANER

◆ 3.3.1 CLEANING THE FOAM PRECLEANER

Clean and re-oil the foam precleaner every three months or every 25 hours of operation, whichever occurs first. Service the foam precleaner more frequently if operating the generator in extremely dusty or dirty conditions. Use the following procedure (Figure 3.2):

- Turn the two screws counterclockwise to loosen.
- Remove the cover, foam precleaner and paper filter.
- Remove the foam precleaner from the cover.
- Wash the foam precleaner in liquid detergent and water.
- Wrap the foam precleaner in a clean cloth and gently squeeze it dry.
- Saturate the foam precleaner in clean engine oil. Gently squeeze it in a clean cloth to remove excess oil and to distribute oil (DO NOT TWIST).
- Install the foam precleaner into the cover, followed by the paper filter.
- Install the cover, foam precleaner and paper filter.
- Tighten the two screws to retain the filter in place.

Figure 3.2 – Engine Air Cleaner

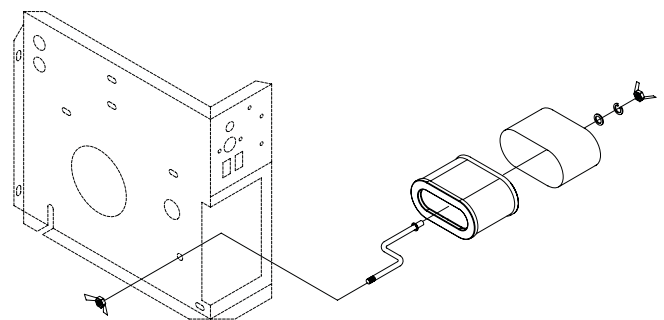

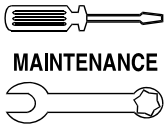

◆ 3.3.2 CLEANING OR REPLACING THE PAPER FILTER

Once each year or every 100 hours of operation (whichever comes first), clean or replace the paper filter. The new replacement filter must be flame retardant. Service the paper filter more frequently if operating the generator in extremely dusty or dirty conditions. Use the following procedure (Figure 3.2):

1. Follow steps 1-3 in "Cleaning the Foam Pre-cleaner"; service the foam pre-cleaner if necessary.
2. Remove the paper filter.
3. Clean the air filter by tapping it gently on a solid surface. If the filter is too dirty, replace it with a new one. Dispose of the old filter properly.
4. Clean the air cleaner cover then reassemble following steps 7-9 in "Cleaning the Foam Pre-cleaner".

3.4 CLEAN AIR INTAKE

Clean all foreign material from the air intake (Figure 3.3) at least once every 100 hours of operation. Clean more often if necessary.

Inspect the area around the generator exhaust muffler periodically and remove all grass, leaves, dirt, etc., from this area.

Figure 3.3 – Cleaning Air Intake

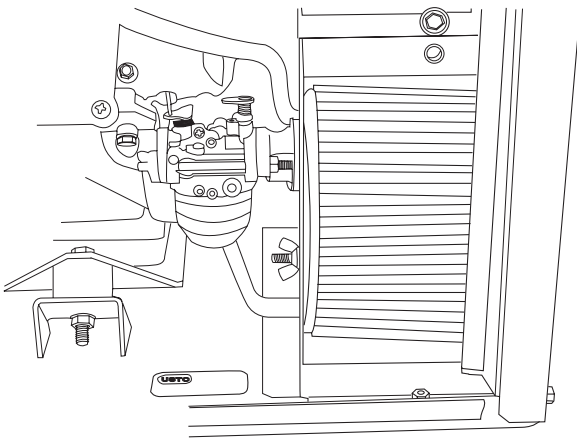

3.5 CHECKING THE ENGINE SPARK PLUG

Clean the spark plug and reset the spark plug gap every 100 hours of operation.

1. Clean the area around the base of the spark plug to keep dirt and debris out of the engine. Remove the spark plug and check the condition. Replace the spark plug if worn or if reuse is questionable.

2. Clean spark plug by scraping or washing using a wire brush and commercial solvent. Do not blast the spark plug to clean.
3. Check the spark plug gap using a wire feeler gauge. Adjust the gap to 0.030 inch (0.76 mm) by carefully bending the ground electrode (Figure 3.4).



⚠ **Sparking can occur if the wire terminal does not fit firmly on the spark plug terminal end. If necessary, re-form the wire terminal to obtain a tight fit.**

Figure 3.4 – Setting the Spark Plug Gap

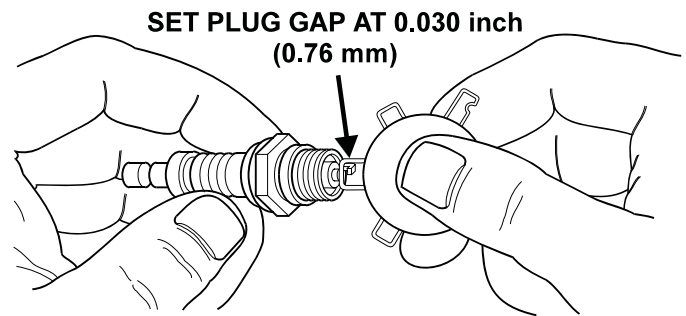

3.6 CLEAN SPARK ARRESTOR

The engine exhaust muffler has a spark arrestor screen. Inspect and clean the screen every 50 hours of operation or once each year, whichever comes first.

NOTE:

If using the generator on any forest-covered, brush-covered or grass-covered unimproved land, it must be equipped with a spark arrestor. The spark arrestor must be maintained in good condition by the owner/operator.

Clean and inspect the spark arrestor as follows:

- Remove the screen retaining bracket by removing the screw (Figure 3.5).
- Slide the spark arrestor screen out from the tail pipe.
- Inspect screen and replace if torn, perforated or otherwise damaged. **DO NOT USE** a defective screen. If screen is not damaged, clean it with commercial solvent.
- Replace the screen and the retaining bracket.

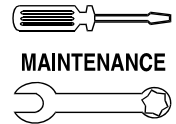
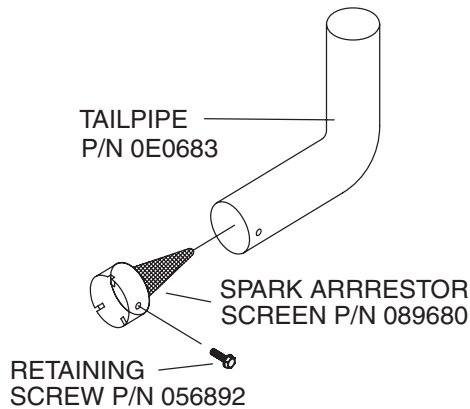

Figure 3.5 - Spark Arrestor



3.7 CLEANING THE GENERATOR

Keep the generator set as clean and dry as possible. Protect the unit against excessive dust, dirt, corrosive vapors, road splash, etc. Permitting dirt and moisture to accumulate on generator windings will have an adverse effect on the insulation resistance of those windings.

When moisture is allowed to remain in contact with windings, some of the moisture will be retained in voids and cracks in the insulation. This causes a reduced insulation resistance and will eventually cause problems. Dirt will make the problem worse, since dirt tends to hold moisture in contact with windings. Salt (as from sea air) also will worsen the problem since it tends to absorb moisture from the air. Salt and moisture, when combined, form a good electrical conductor which can be damaging to the generator windings.



⚠ Do NOT use a forceful spray of water to clean the generator. Water will enter the generator interior and cause problems, and may also contaminate the generator fuel system.

3.8 BATTERY MAINTENANCE

All lead-acid batteries will discharge when not in use. The generator battery should be inspected as follows:

◆ 3.8.1 WEEKLY

- Inspect the battery posts and cables for tightness and corrosion. Tighten and clean as necessary.
- Check the battery fluid level of unsealed batteries and, if necessary, fill with Distilled Water Only. Do not use tap water in batteries.

◆ 3.8.2 EVERY SIX MONTHS

- Have the state of charge and condition checked. This should be done with an automotive-type battery hydrometer.

NOTE:

Servicing of the battery is to be performed or supervised by personnel knowledgeable of batteries and the required precautions. Keep unauthorized personnel away from batteries.

Damage will result if the battery connections are made in reverse.



⚠ Do not dispose of the battery in a fire. The battery is capable of exploding. Storage batteries give off explosive hydrogen gas. This gas can form an explosive mixture around the battery for several hours after charging. The slightest spark can ignite the gas and cause an explosion. Such an explosion can shatter the battery and cause blindness or other injury. Any area that houses a storage battery must be properly ventilated. Do not allow smoking, open flame, sparks, or any spark producing tools or equipment near the battery. Discharge static electricity from body before touching the battery by first touching a grounded metal surface.

⚠ A battery presents a risk of electrical shock and high short circuit current. The following precautions are to be observed when working on batteries:

- Remove watches, rings or other metal objects;
- Use tools with insulated handles;
- Wear rubber gloves and boots;
- Do not lay tools or metal parts on top of the battery;
- Disconnect any charging source prior to connecting or disconnecting battery terminals; and
- Do not use any jumper cables or booster battery to crank and start the generator engine. If any battery has discharged, remove it for recharging.



⚠ Do not open or mutilate the battery. Released electrolyte has been known to be harmful to the skin and eyes, and to be toxic.

⚠ The electrolyte is a dilute sulfuric acid that is harmful to the skin and eyes. It is electrically conductive and corrosive. The following procedures are to be observed:

- Wear full eye protection and protective clothing;
- Where electrolyte contacts the skin, wash it off immediately with water;

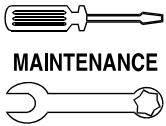

- Where electrolyte contacts the eyes, flush thoroughly and immediately with water and seek medical attention; and
- Spilled electrolyte is to be washed down with an acid neutralizing agent. A common practice is to use a solution of 1 pound (500 grams) bicarbonate of soda to 1 gallon (4 liters) or water. The bicarbonate of soda solution is to be added until the evidence of reaction (foaming) has ceased. The resulting liquid is to be flushed with water and the area dried.

3.9 MAJOR SERVICE MANUAL

To obtain a service manual for the generator, contact the nearest Authorized Service Dealer. Make sure to identify the MODEL NUMBER and SERIES.

3.10 EXERCISING THE GENERATOR

The manufacturer recommends starting and operating the generator at least once every seven days. Let the unit run for at least 30 minutes to “exercise” the engine.

3.11 OUT OF SERVICE PROCEDURE

◆ 3.11.1 REMOVAL FROM SERVICE

If the generator cannot be exercised every seven days, and it is to be out of service longer than 30 days, prepare the generator for storage as follows:

1. Start the engine and let it warm up.
2. Close the fuel shutoff valve in the fuel supply line and allow the unit to shut down.

NOTE:

Using a fuel additive such as STA-BIL fuel stabilizer, or an equivalent, will prevent gum deposits from forming in the engine’s fuel system.

3. While the engine is still warm from running, drain the oil completely. Refill the crankcase with SAE 10W-30 oil having API classification “For Service SF.”
4. Attach a tag to the engine indicating the viscosity and classification of the oil in the crankcase.
5. Remove the spark plug and pour two or three tablespoons of clean, fresh engine oil into the spark plug threaded openings. Reinstall and tighten the spark plug.
6. Remove the battery and store it in a cool, dry room on a wooden board. Never store the battery on any concrete or earthen floor.
7. Clean and wipe the entire generator.

◆ 3.11.2 RETURN TO SERVICE

To return the unit to service after storage, proceed as follows:

1. Check the tag on the engine for oil viscosity and classification. Verify that the correct recommended oil is used in the engine (see Specifications). If necessary, drain and refill with the proper oil.
2. Check the state of the battery. Fill all cells of unsealed batteries to the proper level with distilled water. **DO NOT USE TAP WATER IN THE BATTERY.** Recharge the battery to 100 percent state of charge, or, if defective, replace the battery.
3. Clean and wipe the entire generator.
4. Reconnect the battery. Observe battery polarity. Damage may occur if the battery is connected incorrectly.
5. Turn OFF all electrical loads. Add fuel if necessary and then start the engine.
6. Allow the unit to run for several minutes to warm up.
7. Apply electrical loads to at least 50 percent of the unit’s rated wattage capacity.
8. When the engine is thoroughly warmed up, shut it down.
9. The generator is now ready for service.

3.12 ADJUSTING VALVE CLEARANCE

After the first 50 hours of operation, adjust the valve clearance in the engine.

When adjusting valve clearance, the engine should be at room temperature and the piston should be at Top Dead Center (TDC) of its compression stroke (both valves closed). Correct clearance is 0.001-0.003 inch (0.03-0.07mm). Adjust valve clearance as follows:

1. Loosen the rocker arm jam nut. Use an allen wrench to turn the pivot ball stud while checking clearance between the rocker arm and the valve stem with a feeler gauge (Figure 3.6).

Figure 3.6 — Adjusting Valve Clearance

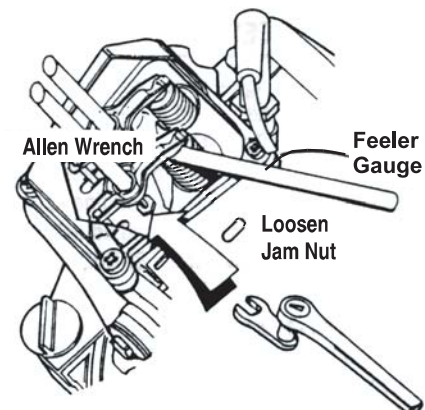

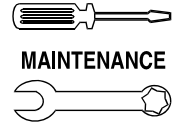

- When valve clearance is correct, hold the pivot ball stud with the allen wrench and tighten the rocker arm jam nut with a crows foot. Tighten the jam nut to 65-85 inch-pounds torque. After tightening the jam nut, recheck valve clearance to make sure it did not change (Figure 3.7).

Figure 3.7 — Tightening Jam Nut

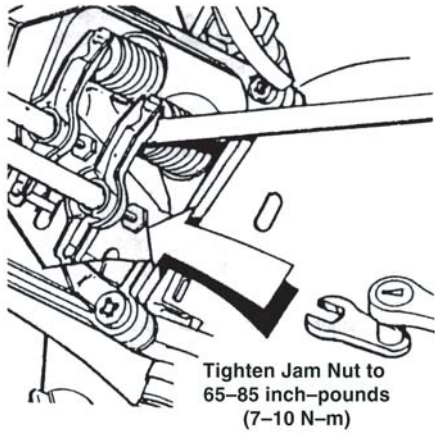

3.13 RV GENERATOR SERVICE INTERVAL

50 Hours.....	Clean Spark Arrestor
100 Hours.....	Change Engine Oil/filter
100 Hours.....	Clean Air Pre-filter
100 Hours.....	Inspect Spark Plugs
250 Hours.....	Replace Paper Air Filter Element
500 Hours.....	Replace Spark Plugs
1st 50 Hours-then every 500 Hrs.	Adjust Valve Lash

PART II – INSTALLATION INSTRUCTIONS

—▲ **DANGER** ▲—

**ONLY QUALIFIED ELECTRICIANS OR CONTRACTORS
SHOULD ATTEMPT INSTALLATION!!**



⚠ DANGER: For fire safety, installation of a generator into a recreational vehicle must comply strictly with article 551, NFPA 70; ANSI C1-1975; AND, ANSI A119.2-1975/NFPA 501C “Standard for Recreational Vehicles” (Part 3, “Installation of Electrical Systems”). In addition, installation must comply with the manufacturer’s instructions and recommendations. **⚠**

NOTICE TO INSTALLER

These *Installation Instructions* have been published by the manufacturer to aid in the installation of the products described in this manual. The manufacturer assumes that installation personnel are familiar with the procedures for installing such products, or similar products manufactured. The manufacturer also assumes that personnel have been trained in the recommended installation procedures for these products and that such training includes (a) use of common hand tools, (b) use of special tools, and (c) use of any tools and/or equipment from other suppliers.

The manufacturer cannot possibly know of and advise the recreational vehicle trade of all conceivable methods, procedures or techniques by which to perform an installation. Nor can the manufacturer anticipate every possible hazard that might result from each installation method, procedure or technique. The manufacturer has not undertaken any such wide evaluation. If using a procedure, work method or operating technique the manufacturer does not specifically recommend, ensure that it is safe for others. Also make sure the procedure, work method or operating technique utilized does not render the generator unsafe.

Information, illustrations, specifications, etc., contained in these *Installation Instructions* are based on the latest information available at the time of publication. Every effort has been expended to be sure that such data is both accurate and current. However, the manufacturer reserves the right to change, alter or otherwise improve this product at any time without prior notice.

⚠ **DANGER** ⚠

⚠ Despite the safe design of this generator, operating this equipment imprudently, neglecting its maintenance or being careless can cause possible injury or death. Permit only responsible and capable persons to operate or maintain this equipment.

⚠ Potentially lethal voltages are generated by these machines. Ensure all steps are taken to render the machine safe before attempting to work on the generator.

⚠ Parts of the generator are rotating and/or hot during operation. Exercise care near running generators.

⚠ **GENERAL HAZARDS** ⚠

- For safety reasons, the manufacturer recommends that the installation, initial start-up and maintenance of this equipment is carried out by an Authorized Service Dealer.
- The engine exhaust fumes contain carbon monoxide, which can be DEADLY. This dangerous gas, if breathed in sufficient concentrations, can cause unconsciousness or even death. This exhaust system must be installed properly, in strict compliance with applicable codes and standards. Following installation, do nothing that might render the system unsafe or in noncompliance with such codes and standards. The generator compartment must be completely vapor sealed from the vehicle interior. There must be no possibility of exhaust fumes entering the vehicle interior. Never operate this equipment with a leaking or defective exhaust system.
- Keep hands, feet, clothing, etc., away from drive belts, fans, and other moving or hot parts. Never remove any drive belt or fan guard while the unit is operating.
- Adequate, unobstructed flow of cooling and ventilating air is critical to correct generator operation and is required to expel toxic fumes and fuel vapors from the generator compartment. Without sufficient cooling airflow, the engine/generator quickly overheats, which causes serious damage to the generator. Do not alter the installation or permit even partial blockage of ventilation provisions, as this can seriously affect safe operation of the generator.
- When working on this equipment, remain alert at all times. Never work on the equipment when physically or mentally fatigued.
- Before performing any maintenance on the generator, disconnect its battery cables to prevent accidental start up. Disconnect the cable from the battery post indicated by a NEGATIVE, NEG or (–) first. Reconnect that cable last.
- Never use the generator or any of its parts as a step. Stepping on the unit can stress and break parts, and may result in dangerous operating conditions from leaking exhaust gases, fuel leakage, oil leakage, etc.
- Never insert any tool or other object through openings in the generator interior, even if the unit is not running; damage to the equipment, or a serious injury may occur.



ELECTRICAL HAZARDS

- The generator covered by this manual produces dangerous electrical voltages and can cause fatal electrical shock. Avoid contact with bare wires, terminals, connections, etc., while the unit is running. Ensure all appropriate covers, guards and barriers are in place before operating the generator. If work must be done around an operating unit, stand on an insulated, dry surface to reduce shock hazard.
- Do not handle any kind of electrical device while standing in water, while barefoot, or while hands or feet are wet. **DANGEROUS ELECTRICAL SHOCK MAY RESULT.**
- During installation onto the vehicle, properly ground (bond) the generator either by solid mounting to the vehicle frame or chassis, or by means of an approved bonding conductor. **DO NOT** connect the bonding conductor to any generator part that might be removed or disassembled during routine maintenance. If the grounding conductor must be replaced, use only a flexible conductor that is of No. 8 American Wire Gauge (AWG) copper wire minimum.
- If the vehicle electrical circuits can be powered by any other source of electricity (such as a “dockside” power receptacle), there must be no possibility of connecting the different power sources to the vehicle circuits at the same time. The dockside (utility) power source must be positively isolated from the vehicle circuits whenever the generator is operating. Failure to isolate the vehicle circuits from the dockside power supply when the generator is running may result in damage to the generator or serious injury or death to dockside (utility) power workers due to backfeed of electrical energy.
- In case of accident caused by electric shock, immediately shut down the source of electrical power. If this is not possible, attempt to free the victim from the live conductor. **AVOID DIRECT CONTACT WITH THE VICTIM.** Use a nonconducting implement, such as a rope or board, to free the victim from the live conductor. If the victim is unconscious, apply first aid and get immediate medical help.
- Never wear jewelry when working on this equipment. Jewelry can conduct electricity resulting in electric shock, or may get caught in moving components causing injury.

FIRE HAZARDS

- For fire safety, the generator must be installed and maintained properly. Installation always must comply with applicable codes, standards, laws and regulations. Adhere strictly to local, state and national electrical and building codes. Comply with regulations the Occupational Safety and Health Administration (OSHA) has established. Also, ensure that the generator is installed in accordance with the manufacturer’s instructions and recommendations. Following proper installation, do nothing that might alter a safe installation and render the unit in noncompliance with the aforementioned codes, standards, laws and regulations.
- Keep a fire extinguisher in the vehicle at all times. Extinguishers rated “ABC” by the National Fire Protection Association are appropriate for use on the recreational vehicle generator electrical system. Keep the extinguisher properly charged and be familiar with its use. If there are any questions pertaining to fire extinguishers, consult the local fire department.

EXPLOSION HAZARDS

- Do not smoke around the generator. Wipe up any fuel or oil spills immediately. Ensure that no combustible materials are left in the generator compartment, or on or near the generator, as **FIRE** or **EXPLOSION** may result. Keep the area surrounding the generator clean and free from debris.
- Gasoline is extremely **FLAMMABLE** and its vapors are **EXPLOSIVE**. Do not permit smoking, open flame, sparks or any source of heat in the vicinity while handling gasoline. Comply with all laws governing the storage and handling of gasoline.
- Fuel lines must be properly installed and fastened, and free of leaks. There must be no possibility of gasoline vapors entering the vehicle interior.
- It is required that an approved, flexible, nonconductive fuel line be installed between the generator fuel connection point and rigid fuel lines.

1.1 PURPOSE AND SCOPE OF THE MANUAL

These *Installation Instructions* have been prepared especially for the purpose of familiarizing installers and owners of the applicable equipment with the product's installation requirements. Give serious consideration to all information and instructions in the manual, both for safety and for continued reliable operation of the equipment.

Because of the different recreational vehicle models and the variations between the models, it would be extremely difficult, if not impractical, to provide detailed instructions for every possible installation. For that reason, instructions and illustrations in this manual are general in nature. Illustrations are not intended to serve as detailed installation blueprints.

The installation should comply strictly with all applicable codes, standards and regulations pertaining to the installation and use of this product. If any portion of this manual appears to be in conflict with such codes, standards or regulations, the applicable codes, standards or regulations must take precedence over the manual.

1.2 SAFETY

Before handling, installing, operating or servicing this equipment, carefully read the "Notice to Installer" and "Safety Rules" on pages 18 and 19. Comply with all safety rules to prevent death, personal injury or damage to equipment and/or property. Stress safety to all installers, operators and service technicians who work on this equipment.

1.3 STANDARDS BOOKLETS

Installation, use and servicing of this equipment should comply strictly with published standards, as well as the manufacturer's recommendations. The following standards booklets (latest revision) are available from the sources indicated:

1. NFPA Standard 501C, "Standard for Recreational Vehicles," available from the National Fire Protection Association, Batterymarch Park, Quincy, MA 02269.
2. NFPA 70, "NFPA Handbook of the National Electric Code," available same as Item 1.
3. ANSI C1-1975 and ANSI 119.2-1975, available from the American National Standards Institute, 1430 Broadway, New York, NY 10018.
4. ANSI A119.2/NFPA 501C, available from the Recreational Vehicle Association, 1896 Preston White Drive, Reston, VA 22090.
5. California Administrative Code, Title 25, available from the State of California, Documents Section, P.O. Box 1015, North Highlands, CA 95660.

6. CSA Electrical Bulletin 946, available from the Canadian Standards Association, Housing and Constructions Materials Section, 178 Rexdale Boulevard, Rexdale, Ontario, Canada, M9W 1R3.

1.4 EQUIPMENT DESCRIPTION

Instructions and information in this section pertain to air-cooled generators. This generator is designed specifically for installing in recreational vehicles. This generator operates 120-volts, single-phase, 60-Hertz, AC electrical loads that require 28.3 amps.

1.5 GENERATOR ENGINE OPERATING SPEED

The generator's revolving field (rotor) is driven by a single-cylinder, four-cycle engine. The generator supplies 120 volts AC at 60 Hertz when the rotor is operating at 3,600 rpm.

1.6 GENERATOR AC CONNECTION SYSTEM

The generator is equipped with dual stator power windings as shown in Figure 1.1.

Figure 1.1 – 120-volt Single Voltage Connection

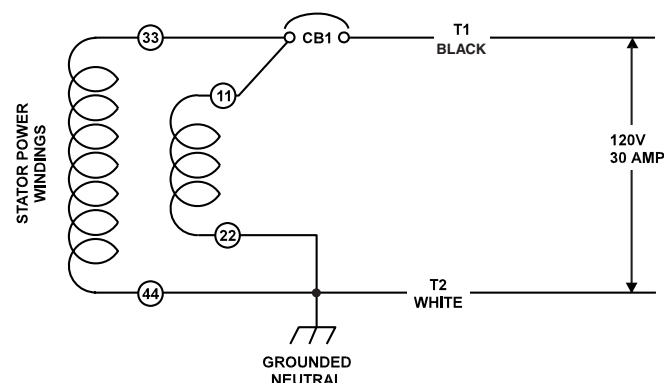

- The AC connection system on these air-cooled generators uses a GROUNDED neutral.
- A separate green ground wire is connected to the recreational vehicle's junction box.

NOTE:

Do NOT connect loads in excess of circuit breaker ratings.

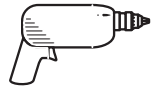

2.1 LOCATION AND SUPPORT

◆ 2.1.1 GENERATOR LOCATION

The most desirable location for the generator set is between the vehicle's main frame members. However, this is seldom possible. Most units must be installed on the side of the vehicle and are difficult to reinforce.

Many recreational vehicles have been factory equipped with an area for the generator set. Some vehicles may even have a generator compartment provided by the vehicle manufacturer.

Plan the generator location based on the following:

- The generator set must be installed on a framework that is part of the recreational vehicle, as outlined in the "Generator Support" section.
- The location must provide an access opening that is large enough to permit generator removal (unless the generator is to be removed from underneath the supporting framework).
- The location must provide easy access to frequently serviced components, such as filters, oil drains, spark plugs and other common maintenance parts.
- The location must provide sufficient room to allow minimum clearances as outlined in "Generator Compartments". If sound insulation is to be used on the compartment walls and ceiling, the minimum recommended applies to the space between the generator and such insulation.
- The location must provide adequate cooling and ventilating airflow for the generator without a great deal of work and expense.
- If mounting the generator in an enclosed compartment, the base of the generator must rest flat on the floor without any gaps.
- When using a suspended mounting system, ensure the base of the generator is flush with the surrounding bodywork. If the unit is mounted higher in the structure, heated air may recirculate into the generator causing it to overheat.

◆ 2.1.2 GENERATOR SUPPORT

The generator must be securely attached to a metal framework that has been made part of the vehicle frame structure by bolting or welding. The metal framework on which the generator will rest and which will restrain the generator set should consist of at least two horizontal beams. These beams should consist of (a) 1-1/2-inch square, 11-gauge steel tubing OR (b) 1-1/2-inch, 11-gauge angle iron. A typical supporting frame with horizontal support tubing, is shown in Figure 2.1.

The generator can be installed so that it sits on top of the horizontal support tubing if the vehicle design permits. Another method is to suspend the generator below the horizontal support tubing by means of suitable, structurally sound metal framework. The following general rules apply:

- Vehicle construction MUST be capable of supporting the weight of the generator.
- Whether the generator is mounted above the horizontal support tubing or suspended below the tubing, the supporting frame used must be structurally sound.
- If the generator cannot be bolted directly to the supporting frame or support tubing, consider using additional tubing, angle brackets or other supports to give the supporting frame sufficient strength.

Figure 2.1 – Typical Horizontal Support Frame

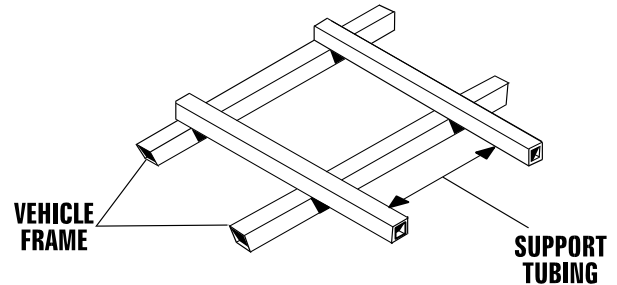

◆ 2.1.4 GENERATOR RESTRAINT

Use four 5/16"-18 hardened steel bolts (Grade 5) to fasten the generator to the supporting frame or the support tubing. These bolts must pass through (a) the generator mounting base, (b) the compartment floor (if a compartment is used) and (c) the supporting framework (Figure 2.2). All bolts must be long enough so that when tight, at least three threads are visible past the retaining lock nuts. Refer to "Generator Compartments" for the location of the generator mounting holes.

Figure 2.2 – Typical Generator Restraint

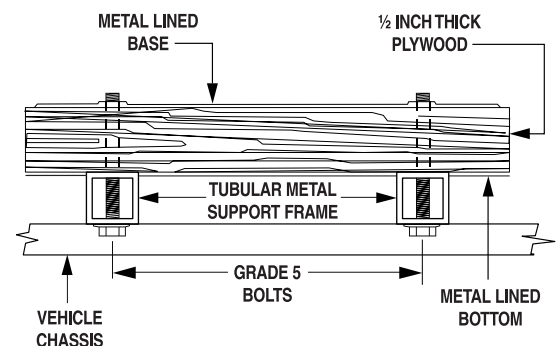



2.2 GENERATOR COMPARTMENTS

Whether the generator set is being installed inside a compartment specifically manufactured to house a generator or inside a compartment that the installer constructs, the compartment must meet certain specifications as outlined in the following sections:

◆ 2.2.1 COMPARTMENT SIZE

Plan the compartment size carefully. Provide a minimum clearance of 1/2 inch (13 mm) on the front and top, 1/2 inch (13 mm) on the left side, two (2) inches on the right side, and 2-1/2 inch (63.5 mm) from the back for air circulation AFTER the compartment has been lined with metal and sound insulation (Figure 2.3).

Figure 2.3 – Clearances

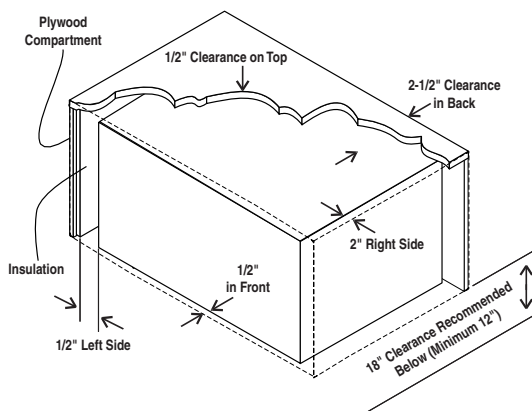

NOTE:

Refer to “Figure 1.2 – Major Features and Dimensions”.

◆ 2.2.2 COMPARTMENT CONSTRUCTION

- The generator compartment should be either constructed of, or lined with, 26-gauge galvanized steel.

NOTE:

Aluminum is NOT an acceptable alternative to galvanized steel due to aluminum’s low melting point.

- If the compartment is lined with galvanized steel, it may be constructed of any material. The manufacturer recommends that the compartment be constructed of 1/2-inch thick plywood (not strand-board), with the floor made of a double thickness of 1/2-inch plywood with the grain of the wood at cross section for added strength (Figure 2.4).
- If constructing a compartment, line the exterior (underside) of the compartment floor with 26-gauge galvanized steel.

Figure 2.4 – Typical Compartment Construction

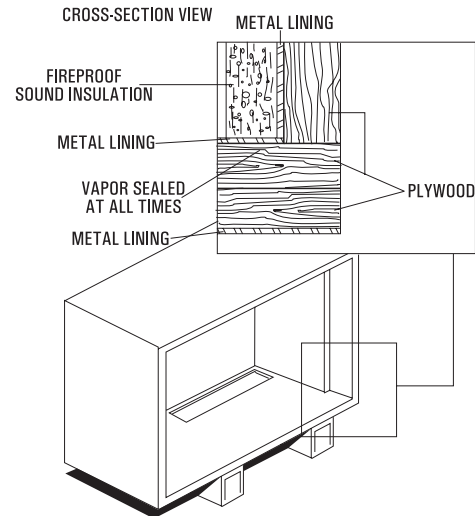

- All seams, splices and joints of the compartment walls (unless vapor tight by design) should be caulked to prevent poisonous, flammable or explosive vapors from entering the vehicle interior.

NOTE:

Caulking must be done so that the caulking material will stay in place permanently. Pressing such materials as putty tape onto joints and seams is NOT acceptable. A high quality silicone rubber base sealant is recommended.

- Holes and openings made in the compartment walls to allow for the passage of electrical conduit, conductors, hoses, cables, etc., into the vehicle living area must be sealed vapor tight with silicone rubber base sealant.
- If flexible metal conduit is used, it must be sealed internally at the end where it terminates inside the compartment’s electrical junction box.

NOTE:

Flexible metal conduit, due to its unique construction, is NOT vapor tight along its entire length.

- Seams and joints of the galvanized steel (whether used as a liner or for the compartment itself) must be lapped and mechanically secured. Such seams may be manufactured, welded, bolted, riveted or screwed. Manufactured lock seams are shown in Figure 2.5. Installer constructed compartments typically utilize a standard lap joint.
- After the compartment has been metal lined and vapor sealed, line the compartment interior walls and ceiling with an approved, nonflammable sound insulating material.

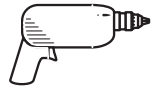
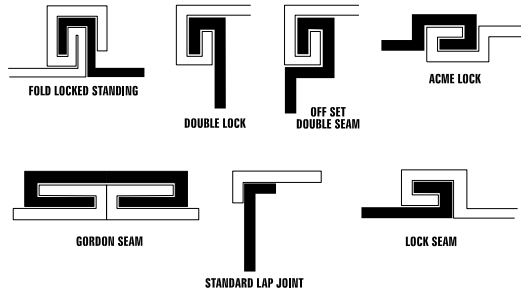

Figure 2.5 – Types of Lock Seams



— **⚠ DANGER ⚠** —

⚠ Do not install any flammable material directly above or around the compartment. Heat, transferred through the compartment structure, may be sufficient to ignite, char or discolor seat cushions, fiberboard and other flammable materials. Use approved nonflammable insulating materials in high temperature areas.

◆ **2.2.3 SOUND INSULATING MATERIALS**

Once installers have determined that a compartment is properly constructed and metal lined, they can add acoustical material. This may include additional sealant or insulating material, to reflect noise away from the vehicle interior.

Sound insulating materials should be of a nonflammable type. One excellent insulating material is a 1-inch (25 mm) thick fiberglass having a 2-pound density. When fiberglass is used, its coated side should face toward the compartment interior.

— **⚠ DANGER ⚠** —

⚠ Do not install sound insulation or any absorbent material on the compartment floor interior. Such materials will become soaked with combustible or explosive vapors and liquids and will become a fire hazard.

Using a combination of sound insulating materials can often reduce noise more effectively than a single material. For example, a sheet of lead or visco-elastic material, along with a layer of other acoustical material, is more effective than when a single material is used.

◆ **2.2.4 ACOUSTICS**

For additional noise abatement, the installer may wish to consider the following:

- Using special sound insulating materials.
- Construction of a special noise abatement compartment.

NOTE:

Any method used to reduce noise must not adversely affect the flow of cooling and ventilating air into or out of the compartment.

In addition to the effective use of sound insulating materials, construction of a special noise abatement compartment might be considered to reduce noise levels. Such a compartment might be constructed as follows (Figure 2.6):

- Use 5/8-inch thick or 3/4-inch thick plywood in the compartment.
- Construct the compartment floor of a double thickness of 5/8-inch or 3/4-inch plywood.
- Line the compartment interior walls and floor, as well as the underside of the floor, with 26-gauge galvanized steel.
- Vapor seal all compartment seams and joints.
- Over the galvanized steel lining, install a combination of acoustical materials.

— **⚠ DANGER ⚠** —

⚠ To prevent fire or explosion, do not install any insulation or other absorbent materials on the interior or underside of the compartment floor.

- Seal all compartment door edges to prevent noise leakage around the door perimeter.
- Line the compartment door interior (except for air openings) with suitable, fireproof sound insulation (such as 1-inch (25 mm) thick fiberglass with a 2-pound density).

Figure 2.6 – Typical Noise Abatement

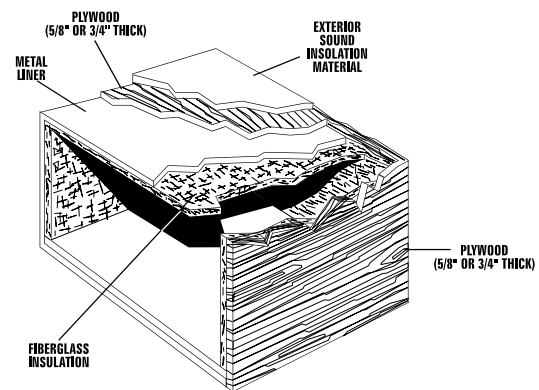

◆ **2.2.5 COMPARTMENT FLOOR CUTOUTS**

Provide openings in the generator compartment for the following items (Figure 2.7):

- Engine exhaust and cooling air outlets
- Generator cooling air inlet
- Four holes for passage of generator mounting bolts.

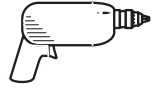
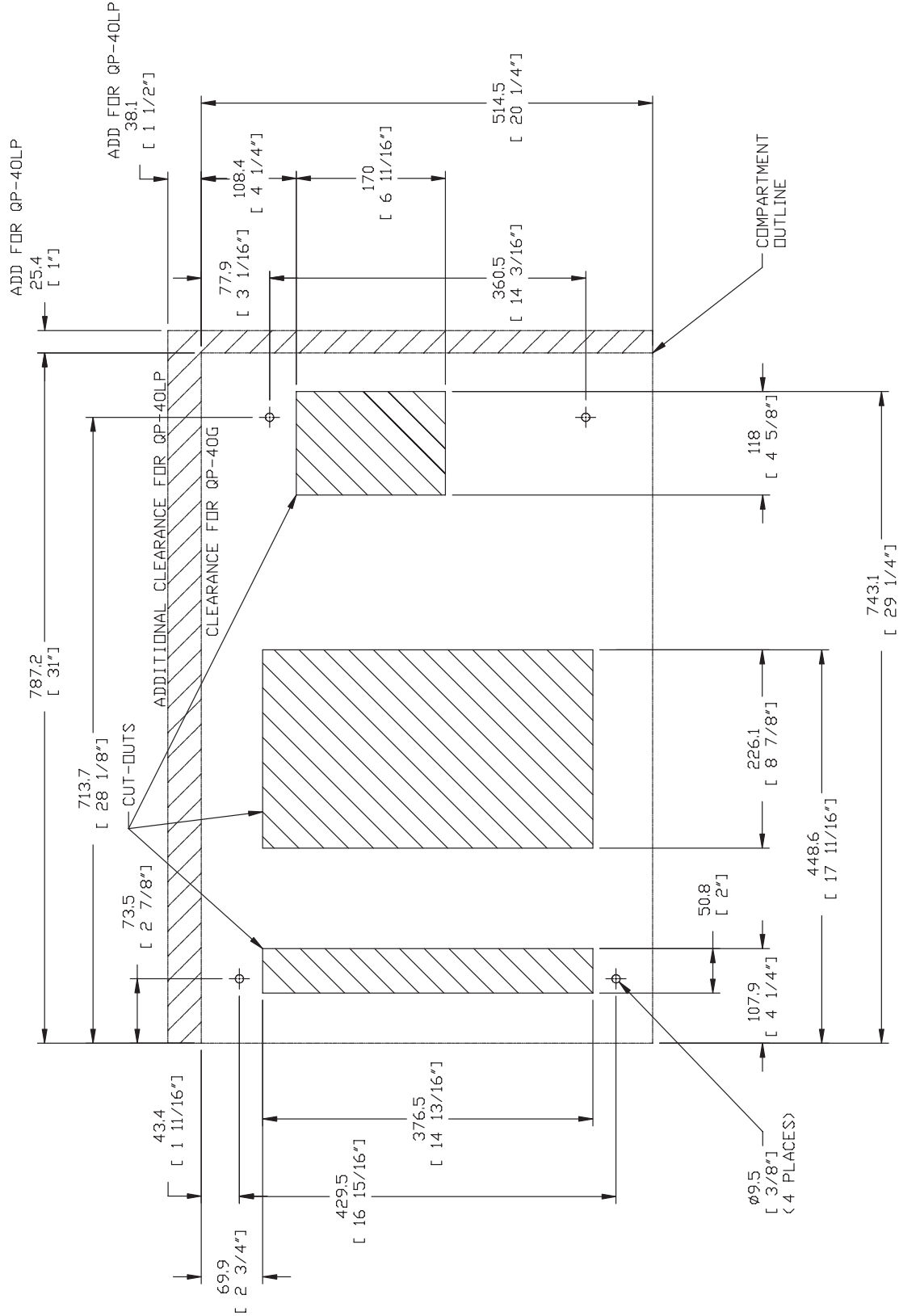

Figure 2.7 – Compartment Floor Cutout (Drawing 0G3723-A)

VIEW FROM TOP

DIMENSIONS ARE IN MM [INCHES]



CONTACT GUARDIAN RV SALES:
RVtemplates@generac.com
FOR A FULL SIZE
INSTALLATION TEMPLATE

NOTE: ALL AIR INTAKES AND EXHAUST OUTLETS MUST BE KEPT CLEAR OF ANY OBSTRUCTIONS. ALL OPEN AREA IS REQUIRED FOR COOLING.

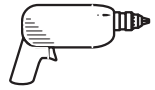

— **⚠ DANGER ⚠** —

⚠ Fuel lines and exhaust piping must not penetrate into the vehicle living area.

2.3 COOLING AND VENTILATING AIR

It is absolutely essential that an adequate flow of air for cooling, ventilating and engine combustion be supplied to the generator set. Without sufficient airflow, the engine/generator quickly overheats. Such overheating can cause serious operating difficulties and also may cause fire and personal injury. The installer must make sure that sufficient air is available to the generator for cooling, ventilating and combustion. The installer also must provide for a path for exhausting the cooling air to the exterior of a compartment, if so equipped.

— **⚠ DANGER ⚠** —

⚠ Never use discharged cooling air for heating or permit such air to enter the vehicle interior. This air contains deadly carbon monoxide gas and other poisonous, flammable or explosive gases.

◆ 2.3.1 GENERATOR AIRFLOW

Engine operation drives cooling fans for the two-stage cooling air system. A pressure fan draws cooling air into the bottom right side of the generator (Figure 2.8). This airflow cools the engine/generator and electronic components. The second part of the cooling system, a suction fan, draws air that is heated from a hot engine into a collector compartment at the left side of the unit. This heated air (although cooler than exhaust muffler) is then deflected out the bottom toward the ground.

Figure 2.8 – Airflow Through Engine/Generator



◆ 2.3.2 TESTING THE INSTALLATION

The manufacturer recommends testing the installation to be sure adequate cooling airflow is available to the unit before placing the unit into service. If the unit shows signs of overheating, enlarge the air openings. Never place a unit into service until absolutely certain that cooling and ventilation is adequate.

NOTE:

Test the installation, especially if bringing in air from below the generator set.

2.4 LP GAS FUEL SYSTEM

— **⚠ DANGER ⚠** —

⚠ LP gas is highly EXPLOSIVE. The gas is heavier than air and tends to settle in low areas. Even the slightest spark can ignite it and cause an explosion. Only competent, qualified people should be allowed to install, test, adjust or service an LP gas fuel system. Install the optional fuel system in compliance with applicable codes, standards and regulations. After the installation, do not do anything that might render the system in noncompliance with applicable codes and standards.

The LP powered range of generators are fitted with a nonadjustable, factory set system. These systems are tamper-proof to meet 1997 California Air Resources Board requirements for engine emission.

◆ 2.4.1 PARTS NOT INCLUDED IN FUEL SYSTEM

The propane fuel system does NOT include such items as (a) gas tank, (b) gas piping, (c) fittings, (d) valves, and (e) primary regulator, used to store the gaseous fuel and deliver it to the gaseous fuel solenoid (Figure 2.9).

— **⚠ DANGER ⚠** —

⚠ Use only approved components in the fuel supply system. All components must be properly installed in accordance with applicable codes. Improper installation or use of unauthorized components may result in fire or an explosion. Follow approved methods to test the system for leaks. No leakage is permitted. Do not allow fuel vapors to enter the vehicle interior.



Figure 2.9 – Typical Propane Gas Fuel System

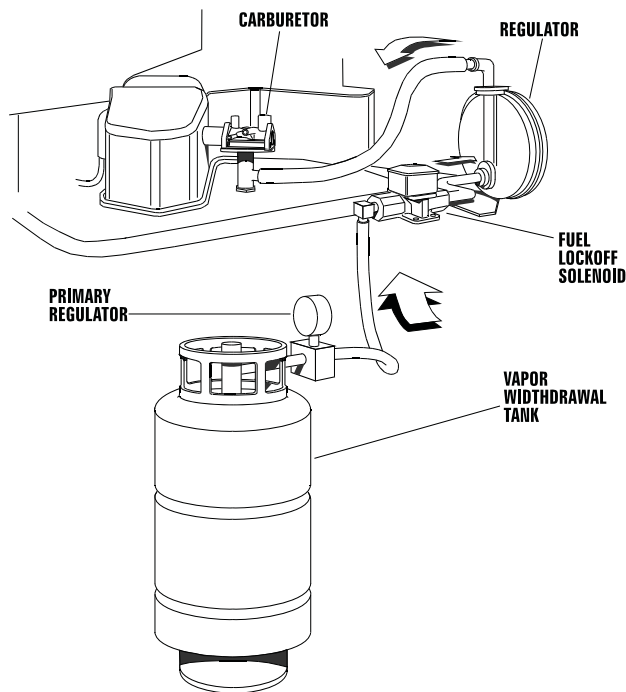

◆ 2.4.2 SOME IMPORTANT CONSIDERATIONS

When installing an LP gas system, consider seriously the following items:

- All fittings, lines, hoses and clamps must be tight and free of leaks. Apply a pipe sealant to threads when assembling threaded connections. This reduces the possibility of leakage.
- Test the entire fuel system for leaks using approved test methods.
- Optimum gas pressure at the inlet to the gaseous fuel solenoid valve and secondary regulator is 11 inches water column.
- The installer's fuel supply connection point is at the gaseous fuel solenoid valve. This is a 3/4-inch (female) connection. Provide a suitable 3/4-inch NPT (male) connector to attach to the fuel supply line.
- Use a length of approved flexible fuel hose between the gaseous fuel solenoid valve and rigid gas piping. The flexible line should be at least 6 inches longer than necessary.

◆ 2.4.3 VAPOR WITHDRAWAL

LP gas is stored in pressure tanks as a liquid. The gas systems used with these generators were designed only for vapor withdrawal type systems. Vapor withdrawal systems use the gas vapors that form above the liquid fuel in the tank. Do NOT attempt to use the generator with any liquid withdrawal type system.

◆ 2.4.4 PRIMARY REGULATOR

Gas pressure delivered to the solenoid valve must be properly regulated by means of a primary gas regulator. Mount the primary regulator at the gas tank outlet or in the supply line from the gas tank. The following rules apply:

- For best results, the primary regulator supplies gaseous fuel to the secondary regulator at 11 inches water column. Do NOT exceed 14 inches water column.
- The installer must be sure the primary regulator is rated at sufficient gas flow to operate the generator plus all other gas appliances in the circuit.

NOTE:

Recommended MINIMUM gas flow rate for these air-cooled generators is 40 cubic feet per hour.

If an existing primary gas regulator does not have a sufficient flow capacity for the generator and other gas appliances in the circuit, (a) install a primary regulator with adequate flow rate, or (b) install a separate regulator only and rated at least 40 cubic feet per hour. The inlet side of any primary regulator that supplies the generator must connect directly to a gas pressure tank. Do NOT tee the generator line into a gas circuit feeding other areas.

◆ 2.4.5 GASEOUS CARBURETION

LP gas vapors should be supplied to the secondary regulator inlet at about 11 inches water column (positive pressure). The engine pistons draw air in during the intake stroke (Figure 2.10). This air passes through a carburetor venturi, which creates a low pressure that is proportional to the quantity of air being pumped. The low pressure from the carburetor venturi acts on the regulator diaphragm to pull the diaphragm toward the source of low pressure. A lever attached to the diaphragm opens a valve to permit gas flow through the carburetor.

Figure 2.10 – LP Gas Carburetion Diagram



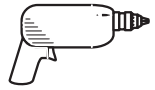

The greater the airflow through the carburetor venturi, the lower the pressure at the venturi throat. The lower the pressure at the venturi throat, the greater the diaphragm movement, and the greater the movement of the regulator valve. The more the regulator valve opens, the greater the gas flow that is proportional to airflow through the generator.

The following facts about the secondary regulator must be emphasized:

- The regulator must be sensitive to venturi throat pressure changes throughout the operating range.
- The regulator must be properly adjusted so it will stop the flow of gas when the engine is not running (no air flow through the carburetor).
- The slightest airflow (and vacuum in the venturi throat) should move the regulator valve off its seat and permit gas to flow.

◆ 2.4.6 FUEL SUPPLY LINES

- LP gas lines must be accessible, but protected against possible damage.
- Do NOT connect electrical wiring to any LP gas fuel line or run wiring alongside the lines.
- Route gas lines away from hot engine exhausts.
- Retain gas lines with metal clamps that do not have sharp edges.
- Install an approved length of flexible hose between the gaseous fuel solenoid valve and rigid fuel supply lines. The flexible line must be nonmetallic, nonorganic and nonconductive. It must be approved for use with LP gas.

◆ 2.4.7 EXCESS FLOW VALVE

LP gas tanks should have an excess flow valve, according to NFPA 501C, Paragraph 3-4.4. This valve and the gas lines must be carefully sized so the valve will close when a fuel line is severed or broken. Consult the Natural-LP Gas Association for information and limitations of excess flow valves.

Manual shutoff valves on the supply tank and elsewhere in the system must be fully open when operating the generator. The excess flow valve functions properly only if all valves are fully open.

◆ 2.4.8 LEAKAGE TESTS

Do not place the generator into service until the gas system has been properly tested for leaks. To test the system, a separate source of 12 volts DC is needed to open the gaseous fuel solenoid valve.

The leak test must comply fully with NFPA, Paragraph 318. All connections, hoses, valve regulators, fittings, and other fuel system parts must be tested under gas or air pressure of not less than 90 psi (620 kPa), while using soap and water or an equivalent solution to check for leaks. Other approved methods of testing for leaks may be used, if appropriate. **DO NOT USE ANY FLAME TO TEST FOR LEAKS.**



- ⚠ **Gaseous fuel lines between the tank and the secondary regulator are under a positive pressure (about 11 inches water column). Gas pressure at the outlet side of the secondary regulator, however, is a negative pressure and can draw flame inside a line or fitting and cause an explosion.**

2.5 EXHAUST SYSTEM

The generator exhaust system must be safely and properly installed. Only approved mufflers and other exhaust system parts must be used. A properly installed exhaust system must be vapor tight, quiet and completely safe.



- ⚠ **The generator engine gives off DEADLY carbon monoxide gas through its exhaust system. This dangerous gas, if breathed in sufficient concentrations, can cause unconsciousness or even death. Never operate the generator set with the vehicle inside any garage or other enclosed area. DO NOT OPERATE THE GENERATOR IF THE EXHAUST SYSTEM IS LEAKING OR HAS BEEN DAMAGED. SYMPTOMS OF CARBON MONOXIDE POISONING ARE (a) inability to think coherently; (b) vomiting; (c) twitching muscles; (d) throbbing temples; (e) dizziness; (f) headaches; (g) weakness; and (h) sleepiness. IF FEELING ANY OF THESE SYMPTOMS, MOVE INTO FRESH AIR IMMEDIATELY. IF SYMPTOMS PERSIST, GET MEDICAL HELP. Do not operate the generator until its exhaust system has been inspected and properly repaired.**



- ⚠ **Never tee the generator engine exhaust pipe into the vehicle engine exhaust piping. This causes excessive back pressure on the generator engine. Also, water from one engine can damage the other engine.**



◆ 2.5.1 SPARK ARRESTOR

This spark arrestor assembly meets code and standard requirements of the U.S. Forest Service. Use only mufflers and parts approved by the manufacturer. Any person(s) installing an unapproved muffler, or an unapproved exhaust system part, or modifying an exhaust system in any way that might cause a hazard, is liable for any damage, injury or warranty expense that might be caused by such unapproved installation or modification.

Failure to provide and maintain a spark arrestor may be in violation of the law. If this generator is used on any forest covered, brush covered or grass covered unimproved land, provide a spark arrestor. The vehicle owner or operator must maintain this device in good condition. In the state of California, the preceding is required by law (Section 4442 of the California Public Resources Code). Other states may have similar laws. Federal laws apply on federal lands.

When installing/replacing the tailpipe or spark arrestor components, verify that the tailpipe has a hole to securely fasten the spark arrestor components (see Figures 2.11 and 2.12). Use only manufacturer supplied hardware. Substitution of parts may cause damage to the screen or a loose fit to the tailpipe.

Figure 2.11 - Spark Arrestor

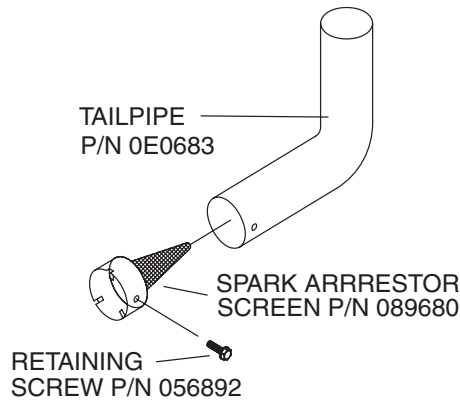
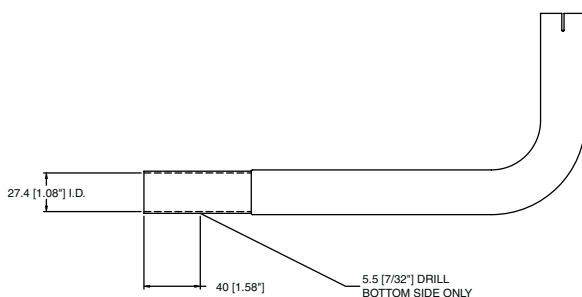

Figure 2.12 — Spark Arrestor Installation



◆ 2.5.2 EXHAUST SYSTEM SAFETY

- Maintain a clearance of at least 3 inches (76 mm) between exhaust system parts and any combustible material (such as wood, felt, cotton, organic fibers or other like material). If the 3-inch (76 mm) clearance cannot be maintained, locate, insulate or shield the exhaust part(s) so that the temperature of any combustible material is not raised more than 117° F (65° C) above the ambient air temperature.
- Extend the exhaust system at least 1 inch (25 mm) past the outer edge of the vehicle. Do not terminate the exhaust system under the vehicle.
- Terminate the exhaust tailpipe such that exhaust gases will not be drawn back into the generator compartment and recirculated.
- If there is any possibility of the tailpipe or muffler being damaged, protect these damage-prone areas by means of a protective device (such as a skid bar).
- Install the generator exhaust system according to safe automotive practices.
- Use enough exhaust system hangers to prevent any part of the system from being dislocated.
- Use exhaust system parts recommended by the manufacturer. Using unapproved exhaust mufflers and exhaust system parts is the responsibility of the person(s) installing such unauthorized parts.
- Do not terminate the exhaust system under any opening, window or vent that can be opened or is not permanently sealed from the vehicle interior.
- Exhaust piping must be large enough to prevent excessive back pressure on the generator engine.
- Never tee the generator engine exhaust pipe into the vehicle engine exhaust piping. This causes excessive back pressure on the generator engine. Also, water from one engine can damage the other engine.
- Plan exhaust system installation carefully. Comply with all applicable codes, standards and regulations.

2.6 ELECTRICAL CONNECTIONS

Be sure to read section "Generator AC Connection System".

The following general rules apply to electrical connections in a recreational vehicle:

- Qualified electricians who are familiar with applicable codes, standards and regulations should install electrical wiring.
- The wiring should comply with codes, standards and regulations. The National Electrical Code (NFPA 70), and state and local codes apply.
- Switches and circuit breakers should be of a type approved for use in recreational vehicles and must be mounted and installed to prevent damage from road shock.

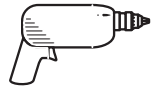

- Wiring must be of adequate size, have approved insulative qualities and be properly supported.
- Conduit and wire openings into the generator compartment (if used) must be vapor-sealed to prevent entry of flammable, explosive or poisonous gases into the vehicle.

◆ **2.6.1 ELECTRICAL JUNCTION BOX**

Install an approved, square electrical junction box with a blank cover on the interior or exterior wall of the area planned for installation of the generator (NOT on the generator). Route the generator's AC output leads into this junction box through approved flexible conduit. This is the point of first termination for generator AC output leads.

◆ **2.6.2 WIRING**

- Wiring should be of stranded copper to reduce the chance that vibration may cause breakage.
 - Wire gauge size should be large enough to handle at least 115 percent of the installed generator's rated maximum current.
 - Neutral conductors must be the same size as other leg wires.
 - Route power supply conductors from generator AC output leads (white), (black) and the green ground wire through approved flexible conduit to the electrical junction box on the compartment wall.
- If flexible metal conduit is used between the generator and the compartment junction box, the conduit end that terminates the compartment junction box must be vapor-sealed. Flexible metal conduit is NOT vapor tight along its entire length.
- From the junction box, route power supply wires through approved conduit to either (a) double-pole, double-throw transfer switch, or (b) approved isolation receptacle. Connecting to a transfer switch or isolation receptacle must prevent vehicle electrical circuits from being connected to two different power supplies at the same time (such as generator and dockside power).
 - Conductors must be rated 221° F (105° C) or must be of a larger conductor size.

◆ **2.6.3 GENERATOR AC CONNECTIONS**

Generator AC output leads (BLACK) “hot” and (WHITE) grounded neutral come out of the generator as shown in Figure 2.13. There is also a green lead that connects to ground in the junction box of the recreational vehicle.

Leads BLACK to WHITE are protected against overload by a 30-amp circuit breaker (CB1). Use this line-to-neutral connection separately to operate 120-volt, single-phase, 60 Hertz, AC loads requiring up to 3,400 watts (3.4 kW) of power.

Figure 2.13 – Generator AC Output Leads

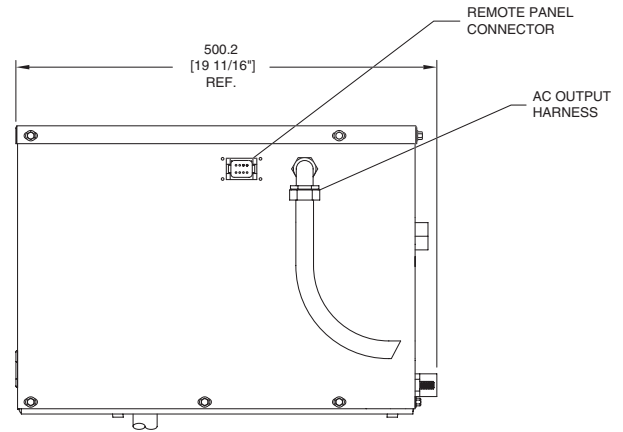

⚠ Do NOT connect electrical loads in excess of any circuit breaker rating or problems with circuit breaker tripping will develop, which causes a loss of AC output. Also, do NOT exceed the generator's rated wattage capacity. Add the watts or amperes of all lighting, appliance, tool and motor loads the generator will operate at one time. This total should be less than the unit's rated wattage/amperage capacity.

◆ **2.6.4 CONDUIT**

Route the connections between the generator and the junction box through approved, flexible conduit. The following general rules apply:

- Cut wiring to the required length and allow extra wire for junction box connections.
- Carefully prepare conduit ends to prevent sharp edges from cutting through wiring insulation.
- Route conduit so it does not interfere with generator movement.
- If using metallic conduit, vapor seal the end of the conduit where it enters the junction box. Do this because flexible metallic conduit is not vaporproof along its entire length.

◆ **2.6.5 ISOLATING DIFFERENT POWER SOURCES**

Connections from the junction box must terminate in a double-pole, double-throw transfer switch (Figure 2.14). An alternate method for isolating different power sources is by using an isolating receptacle (Figure 2.15). Whichever method is used, be certain that both power sources are NOT connected at the same time.

Figure 2.14 – Transfer Switch Isolation Method

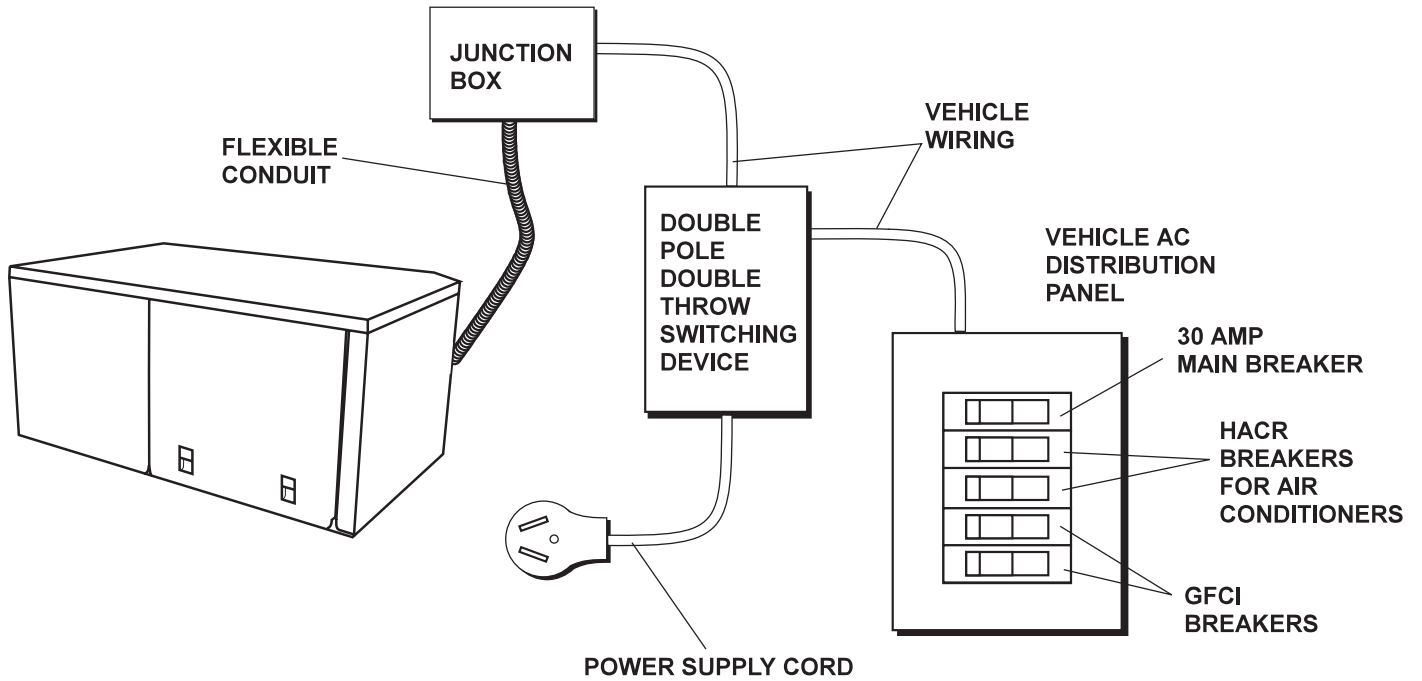
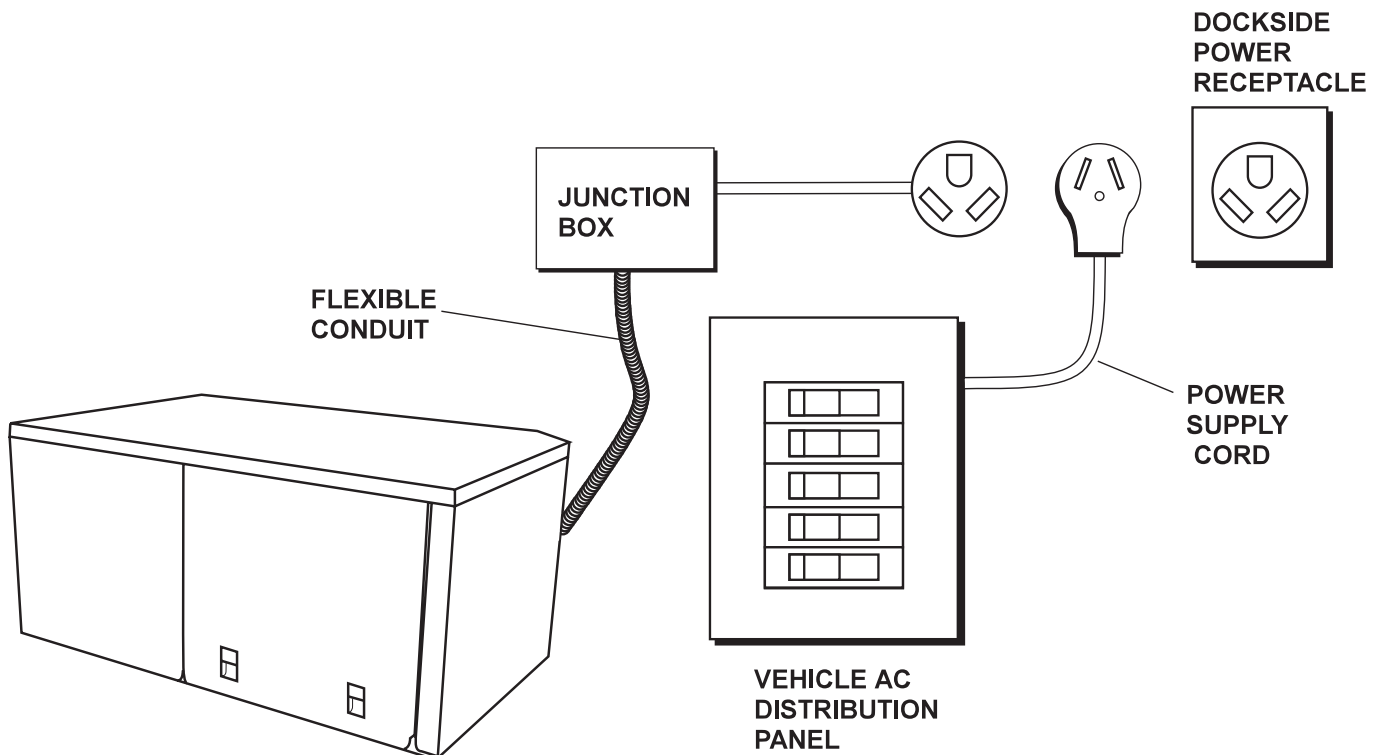
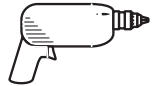

Figure 2.15 – Installation With Isolation Receptacle





◆ 2.6.6 POWER SUPPLY CORD

The power supply cord must comply with all applicable codes, standards and regulations. It must be large enough to handle the full amperage to which it will be subjected.

◆ 2.6.7 GROUND FAULT CIRCUIT INTERRUPTERS

The National Electrical Code (NFPA 70, 551-7) requires that a ground fault circuit interrupters (GFCIs) be installed on all external and some internal electrical receptacles. Contact the dealer for recommendations.

2.7 BATTERY INSTALLATION

◆ 2.7.1 RECOMMENDED BATTERY

Install a battery that meets the following requirements:

- The battery must be a 12-volt, automotive type storage battery.
- For prevailing ambient temperatures above 32° F (0° C), use a battery rated 70 amp-hours and capable of delivering 400 cold-cranking amperes.
- For prevailing ambient temperatures below 32° F (0° C), use a battery rated 95 amp-hours and capable of delivering 400 cold-cranking amperes.

NOTE:

If the battery is to be used to power other vehicle accessories, as well as start the generator, a battery with a larger capacity may be needed.

◆ 2.7.2 BATTERY CABLES

Using battery cables that are too long or too small in diameter may cause a drop in voltage, which causes starting problems. For the best cold weather starting, the voltage drop between battery terminals and the generator connection point should not exceed 0.12 volts per 100 amperes of cranking current.

These generators are rated at about 100 DC amperes of cranking current.

Select battery cables based on (a) cable length and (b) prevailing ambient temperatures. Generally, the longer the cable and the colder the weather, the larger the cable size must be, as shown in the following chart.

CABLE LENGTH in Feet (Meters)	CABLE SIZE
0 to 10 (0 to 3)	2*
11 to 15 (3.4 to 4.5)	0
16 to 20 (4.5 to 6)	000

* For warm weather, use No. 2 cable up to 20 feet.

◆ 2.7.3 BATTERY CABLE CONNECTIONS

1. Connect the battery cable from the battery post or terminal indicated by a POSITIVE, POS or (+) to the lug on the starter contactor (Figure 2.16).

NOTE:

Check to be sure the battery cable boot for the starter cable has been installed.

2. Connect the battery cable from the battery post indicated by a NEGATIVE, NEG or (-) to the frame ground connection (Figure 2.16).
3. Connect cables so the connectors are clean and tight.

Figure 2.16 – Connecting Battery Cables

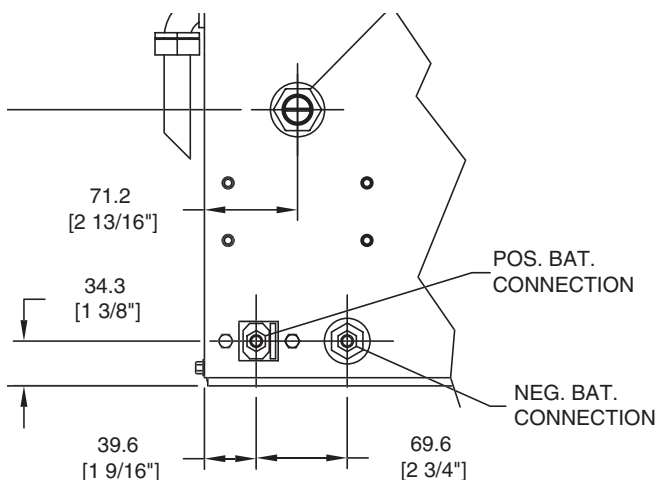

◆ 2.7.4 BATTERY COMPARTMENT

Install the generator battery in its own, vented compartment. Place the battery compartment away from any source of heat, sparks or flame.

Provide ventilation openings in the battery compartment. The minimum size of openings should be 2 square inches at the top of the compartment. Mount the battery on a strong, rigid supporting structure, where leaks and spills of battery fluid will not cause damage.

2.8 OPTIONAL ACCESSORIES

A plug-in receptacle (Figure 2.17) is provided on the generator set. Use this receptacle to connect an optional remote-mounted start/stop panel to the generator. Installation of such a panel will permit starting and stopping the generator engine from any convenient location inside the vehicle.

Figure 2.17 – Remote Panel Plug-in Receptacle

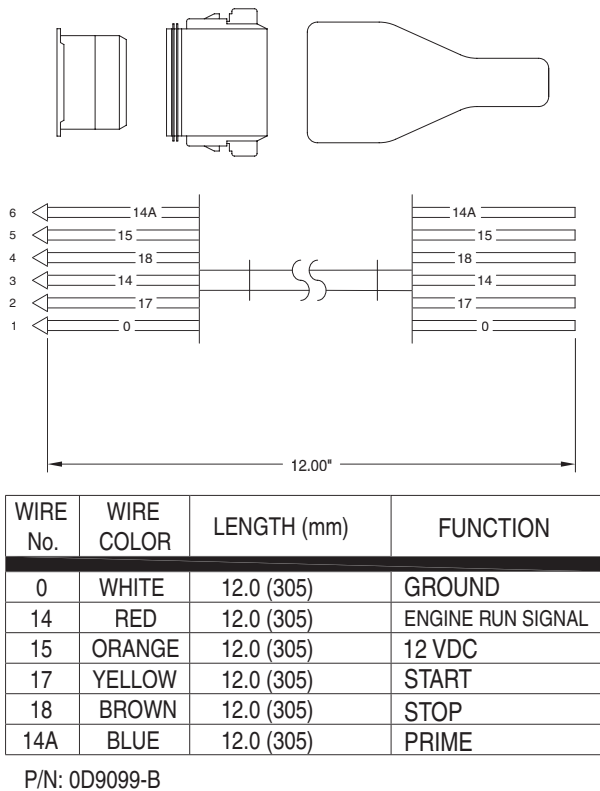

◆ 2.8.1 REMOTE START/STOP PANEL

A remote mounted Start/Stop panel (Figure 2.18) is available that allows the user to start and stop the generator engine conveniently from inside the vehicle. The remote panel includes a Start/Stop switch, hour-meter, generator run lamp, a fuel prime switch, and a wire harness. The hourmeter should be used in conjunction with the maintenance operations found in Part I of this manual.

Figure 2.18 – Optional Remote Panel

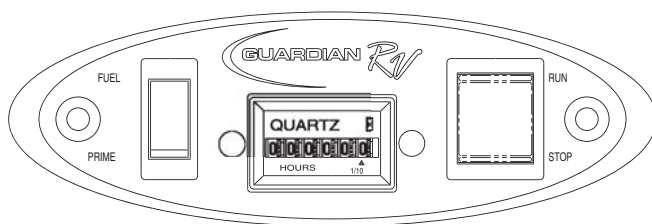

3.1 POST INSTALLATION TESTS

The air-cooled generator set was factory tested and adjusted. It should not be required to adjust the unit any further except under special circumstances.



- ⚠ Do not make any unnecessary adjustments. Factory settings are correct for most applications. When making adjustments, however, be careful to avoid overspeeding the engine.

3.2 BEFORE INITIAL START-UP

Before starting, complete the following:

1. Check the engine crankcase oil level and, if necessary, fill to the dipstick "FULL" mark (cross-hatched area) with the recommended oil. Do not fill above the FULL mark.
2. Check the fuel supply. Gas fuel lines must have been properly purged and leak tested in accordance with applicable fuel codes. All fuel shutoff valves in the fuel supply lines must be open.



- ⚠ If a liquid propane (LP) gas fuel system has been installed, it must be properly tested for leaks before operating the system in compliance with ANSI A119.2/NFPA 501C. No leakage is permitted. Be sure no gasoline fuel vapors enter the vehicle interior.

3.3 INITIAL START

When absolutely certain that the unit has been properly installed and prepared for use, start the engine as follows:

1. Turn off all electrical loads. Do this by setting the generator's main circuit breakers to their "OFF" (or open) position.
2. Refer to Part I, section "Starting the Generator", for cranking and starting instructions. The engine may require more cranking for initial starting since the fuel lines have to be primed (use of the primer switch will shorten this time).
3. Let the engine warm up for about five minutes to allow internal temperatures to stabilize.
4. Carefully inspect the engine/generator for fuel, oil and exhaust system leaks. Before proceeding to the next step, correct any leakage immediately.
5. When all tests and adjustments at no-load are completed, apply electrical loads and check for proper operation under load. See the "Testing Under Load" section. Run the unit at least 30 minutes with loads applied.

6. Turn off all electrical loads by setting the generator's main circuit breakers to their "OFF" (or open) position.
7. Let the unit run at no-load for a few minutes to stabilize internal engine/generator temperatures. Then, shut down the engine.

NOTE:

The generator set was thoroughly tested and adjusted at the factory before shipping. No additional adjustment should be necessary. Only qualified service technicians who have been trained should perform adjustments outlined in this manual.

3.4 TESTING UNDER LOAD

Apply electrical loads equal to about 75 to 100 percent of the unit's rated wattage/ampere capacity.

Let the unit run at least 30 minutes with load applied. During this part of the test, check that the unit is not running excessively hot and that adequate cooling airflow is available. Do not allow the unit to overheat during prolonged operation.

NOTE:

The generator engine is equipped with a high temperature switch. The switch has normally closed (N.C.) contacts. When the engine temperature is too high, switch contacts close, and the engine shuts down automatically.

THE MANUFACTURER RECOMMENDS THAT THE GENERATOR BE TESTED FOR ADEQUATE COOLING.

3.5 INSTALLATION CHECKLIST

◆ LOCATION AND SUPPORT

- Generator is properly located.
- Generator is properly supported.
- Generator is properly restrained.

◆ GENERATOR COMPARTMENT

- Compartment construction is proper.
- Holes/Openings are vapor-sealed.
- Compartment size is correct.
- Compartment is vapor-sealed.
- Sound insulation is correct.
- Floor cutouts are properly completed.

◆ COOLING AND VENTILATING AIR

- Airflow is adequate.
- Air inlet opening is correct.
- Compensate for restrictions.
- Check that installation has been tested.

◆ OPTIONAL LP GAS FUEL SYSTEM

- Fuel system is properly installed and checked for leaks.
- Pressure at regulator inlet is correct.
- Rated flow of primary regulator is correct.
- All parts are properly installed.
- Fuel system is properly tested/adjusted.

◆ EXHAUST SYSTEM

- Exhaust system complies with all applicable codes.
- Exhaust system is properly and safely installed.

◆ ELECTRICAL CONNECTIONS

- Connections comply with local code requirements and all National Electrical Codes.
- Junction box is properly installed.
- Wiring meets all standards.
- All connections are correct.
- Conduit is properly installed and sealed.
- Generator is properly bonded to the vehicle.

◆ BATTERY INSTALLATION

- Recommended battery is installed.
- Recommended cables are installed.
- Cables are clean and tight.
- Cables are connected properly.
- Proper ventilation is provided.
- Terminals are coated with anti-corrosion grease, and terminal covers are positioned.

◆ OPTIONAL ACCESSORIES

- Check that remote start/stop panels (if used) are installed properly.
- Check that hourmeter kit (if used) is installed properly.
- Check that any other options and accessories (if used) are installed properly.

◆ POST INSTALLATION TESTS

- Check that all tests are completed properly.

DATE OF INSTALLATION _____

NAME OF INSTALLER _____

SIGNATURE OF INSTALLER _____



TROUBLESHOOTING GUIDE

Problem	Cause	Correction
The engine will not crank.	<ol style="list-style-type: none"> 1. Fuse blown 2. Loose, corroded or defective battery cables 3. Defective engine Start/Stop switch 4. Defective starter contactor 5. Defective starter motor 6. Low or defective battery 	<ol style="list-style-type: none"> 1. Replace fuse. 2. Tighten, clean or replace as necessary. 3. Replace Start/Stop switch. 4. Replace contactor. 5. Replace starter motor. 6. Charge or replace battery.
The engine cranks but will not start.	<ol style="list-style-type: none"> 1. Out of fuel 2. Defective fuel solenoid 3. Open #14 wire from engine control board 4. Flooded engine 5. Defective spark plug(s) 6. Fuel line shut-off closed 	<ol style="list-style-type: none"> 1. Replenish fuel. 2. Replace fuel solenoid. 3. Check connections and insulation of #14 wires. 4. Wait 5-10 minutes before trying. 5. Clean, re-gap or replace plug(s). 6. Open fuel line shut-off.
The engine starts hard and runs rough.	<ol style="list-style-type: none"> 1. Air cleaner plugged or damaged 2. Defective spark plug(s) 	<ol style="list-style-type: none"> 1. Check, clean or replace air cleaner. 2. Clean, re-gap or replace plug(s).
The engine starts, but shuts down when the Start/Stop switch is released.	<ol style="list-style-type: none"> 1. Engine oil level low 2. Defective low oil pressure switch 3. Defective high temperature switch 4. Defective engine control board 5. Overheated engine 	<ol style="list-style-type: none"> 1. Check oil and add oil as needed. 2. Replace pressure switch. 3. Replace temperature switch. 4. Replace control board. 5. Check that the airflow openings are adequate.
The Start/Stop switch is set to Stop, but the engine continues to run.	<ol style="list-style-type: none"> 1. Defective Start/Stop switch 2. Open/Disconnected #18 wire between Start/Stop switch and engine control board 3. Open/Disconnected #0 wire between Start/Stop switch and engine control board 4. Defective engine control board 	<ol style="list-style-type: none"> 1. Replace switch. 2. Reconnect or close wire. 3. Reconnect or close wire. 4. Replace control board.
There is no AC output from the generator.	<ol style="list-style-type: none"> 1. Main line circuit breaker open 2. Fault with vehicle circuit breaker and/or fuses 3. Transfer switch set to NORMAL 4. Start switch not held long enough to flash the field 5. Generator internal failure 	<ol style="list-style-type: none"> 1. Reset circuit breaker to ON (or closed). 2. Reset and replace if necessary. 3. Set switch to GENERATOR. 4. Stop, then restart the engine (Hold Start switch for at least 2 seconds). 5. Contact an Authorized Service Dealer.

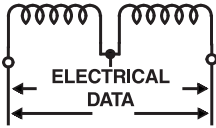

Section 6 – Electrical Data

Recreational Vehicle Generator

Electrical Schematic and Wiring Diagram – Drawing No. 0D8063-D

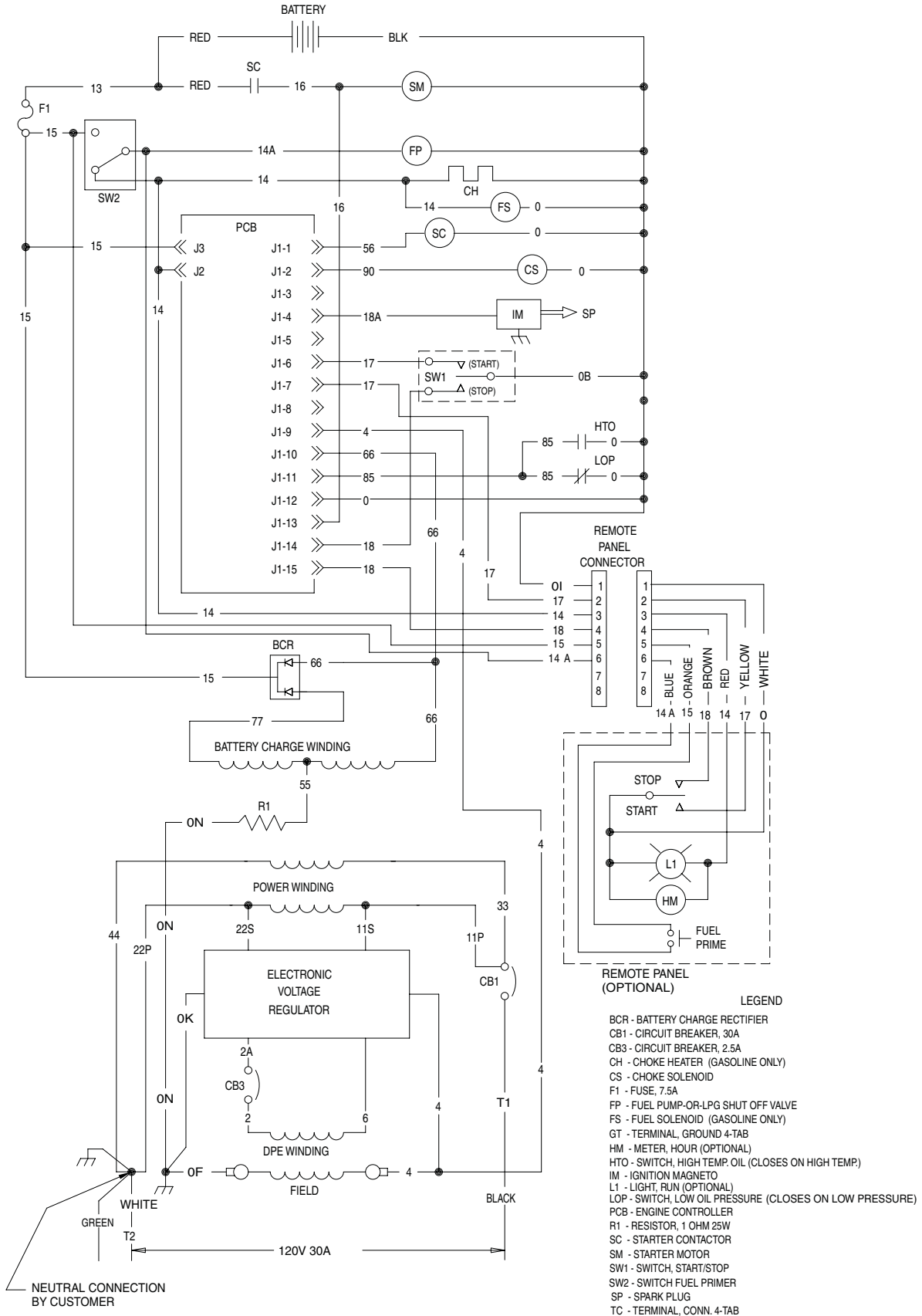

Section 6 – Electrical Data
Recreational Vehicle Generator
Electrical Schematic and Wiring Diagram – Drawing No. 0D8063-D

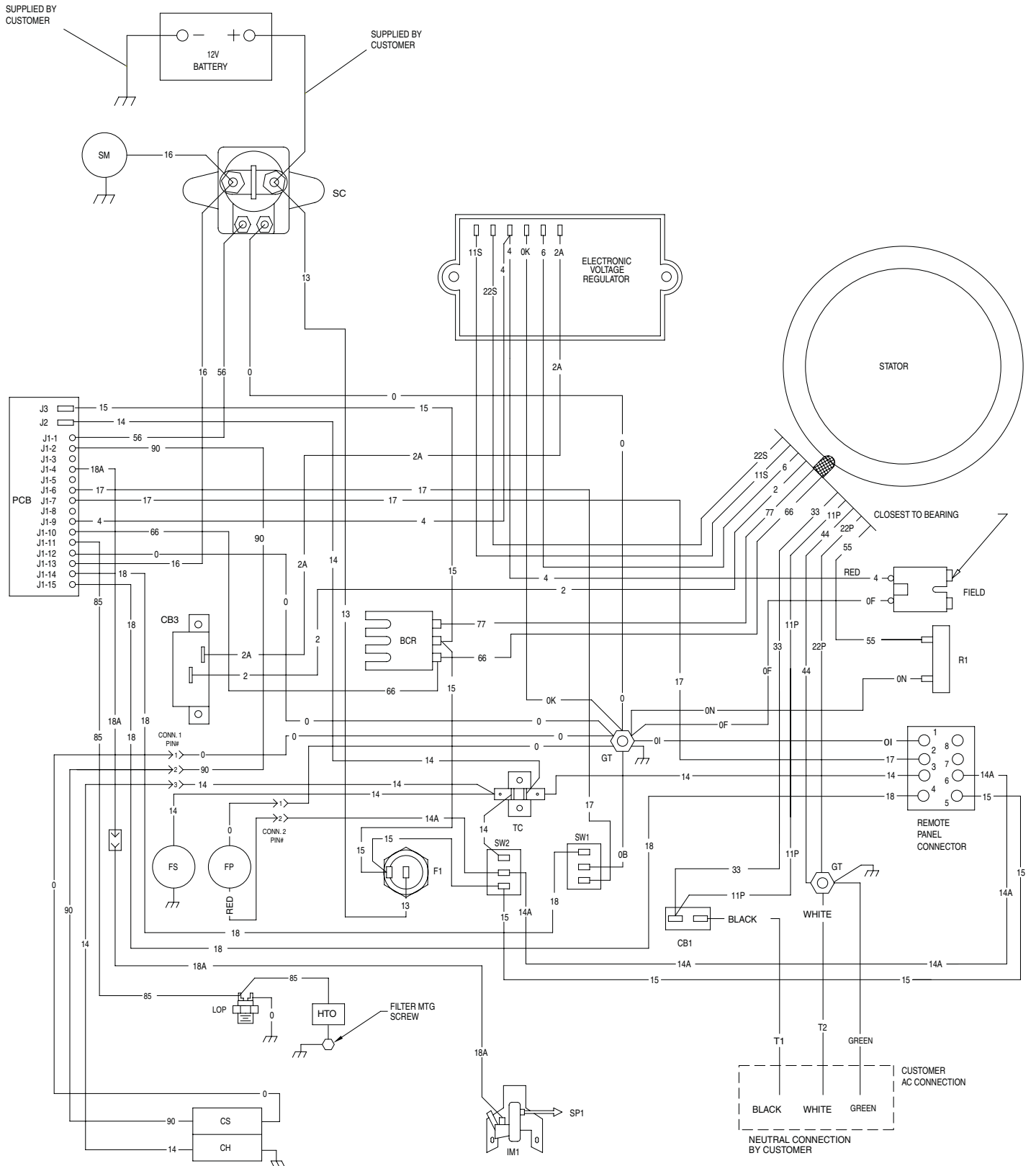
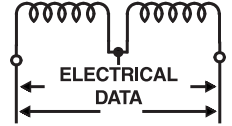

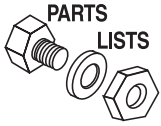

Section 7 – Exploded Views and Parts Lists

Recreational Vehicle Generator Enclosure – Drawing No. 0F4589-B

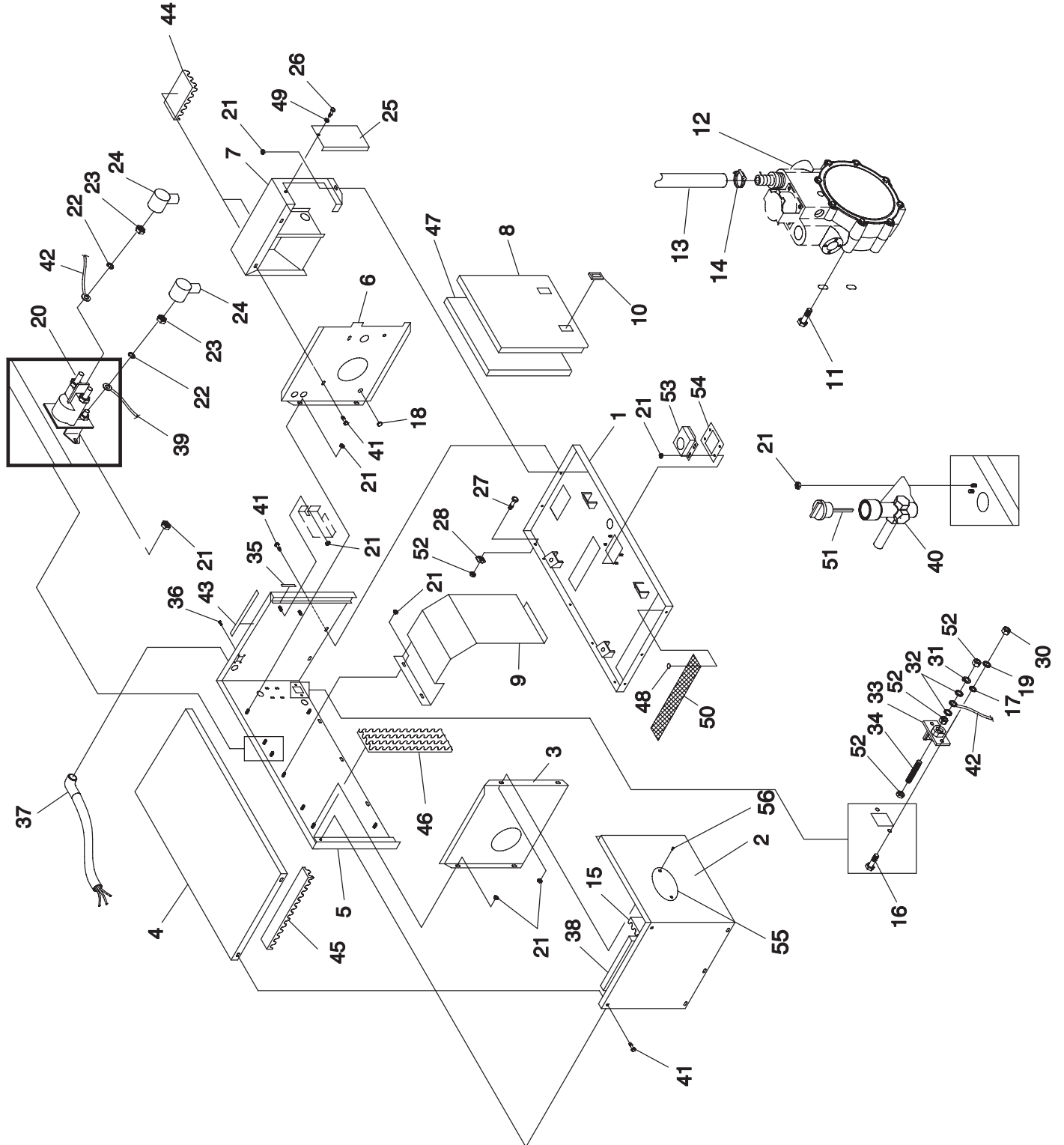

Section 7 – Exploded Views and Parts Lists

Recreational Vehicle Generator Enclosure – Drawing No. 0F4589-B

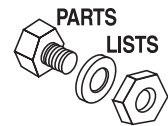

ITEM	PART NO.	QTY.	DESCRIPTION
1	0F3916	1	TRAY, ENCLOSURE
2	0D6942	1	PANEL, ENCLOSURE SIDE
3	0D6939	1	PANEL, REAR DIVIDER
4	0F3920	1	PANEL, ENCLOSURE ROOF
5	0F3917	1	PANEL, ENCLOSURE BACK
6	0F3918	1	PANEL, FRONT DIVIDER
7	0F3919	1	COMPARTMENT, AIR INTAKE
8	0G7329	1	PANEL, ENCLOSURE DOOR
9	0D8254	1	SHIELD, MUFFLER
10	0C5644	2	SLIDE LATCH, FLUSH
11	0A1495	4	SCREW HHTT M4-0.7 X 10mm
12	0E1742A	1	LP REGULATOR
13	047290	1	HOSE 3/8" I.D. SINGLE BRAID 33" LONG
14	048031E	1	HOSE CLAMP BAND 3/8"
15	0D8628B	1	FOAM, FRONT AIR OUT COMPARTMENT
16	047411	2	SCREW HHC M6-1.0 X 16
17	022473	2	WASHER FLAT 1/4"
18	023484S	1	BUSHING, 1.09" SNAP
19	022097	2	WASHER LOCK M6-1/4"
20	086729	1	CONTACTOR, STARTER
21	0D3700	22	NUT FLANGE M6-1.0 NYLOK
22	022129	2	WASHER LOCK M8-5/16"
23	022259	2	NUT HEX 5/16"-18
24	075763A	2	BOOT BATTERY CABLE
25	0D7293	1	PANEL AIR BOX COVER
26	064113	1	SCREW, M6-1.00 x 20mm WING
27	0C7561	1	BOLT CARR 3/8"-16 X 1" BRASS
28	0A4456	1	3/8" SPECIAL L/WASHER
30	049813	2	NUT HEX M6 X 1.0
31	022237	1	WASHER LOCK 3/8"
32	022131	2	WASHER FLAT 3/8-M10"
33	0C5443	1	BLOCK, TERMINAL BATTERY POST
34	0C7423	1	STUD 3/8"-16 X 2"-1/4" BRASS
35	029451	2.1'	TAPE FOAM 1/8" x 1/2"
36	074908	4	SCREW HHTT M5-0.8 X 10
37	0D8717	1	CUSTOMER CONNECTION HARNESS
38	0D9020	1	FOAM, AIR OUT COMPARTMENT SIDE
39	0742600144	1	CABLE, STARTER
40	0E0724	1	ASSEMBLY OIL DRAIN
41	0G4933	20	SCREW SWT 1/4-20 X 5/8 W/W
42	0742600143	1	CABLE, BATTERY CONNECTION
43	029451A	8.75'	FOAM TAPE 1/16" X 1/2"
44	0D8627	2	FOAM, AIR INTAKE COMPARTMENT
45	0D8628	1	FOAM, ROOF AIR OUT COMPARTMENT
46	0D8628A	1	FOAM, BACK COMPARTMENT
47	0D8691	1	FOAM, DOOR PANEL
48	0D7176	4	WASHER SELF LOCKING 1"
49	0A2115	1	WASHER NYLON .250"
50	0D9282	1	HARDWARE CLOTH COMPARTMENT AIR OUT
51	0E0393	1	ASSEMBLY, CAP & DIPSTICK
52	0C7968	4	NUT HEX JAM 3/8"-16 BRASS
53	0E0014	1	BOX, MUFFLER TAIL PIPE
54	0E0017	1	GASKET, MUFFLER TAIL PIPE BOX
55	0G7366	1	LOGO, QP
56	0A9973	2	RIVET, POP

Section 7 – Exploded Views and Parts Lists

Recreational Vehicle Generator
Generator – Drawing No. 0F4590-C

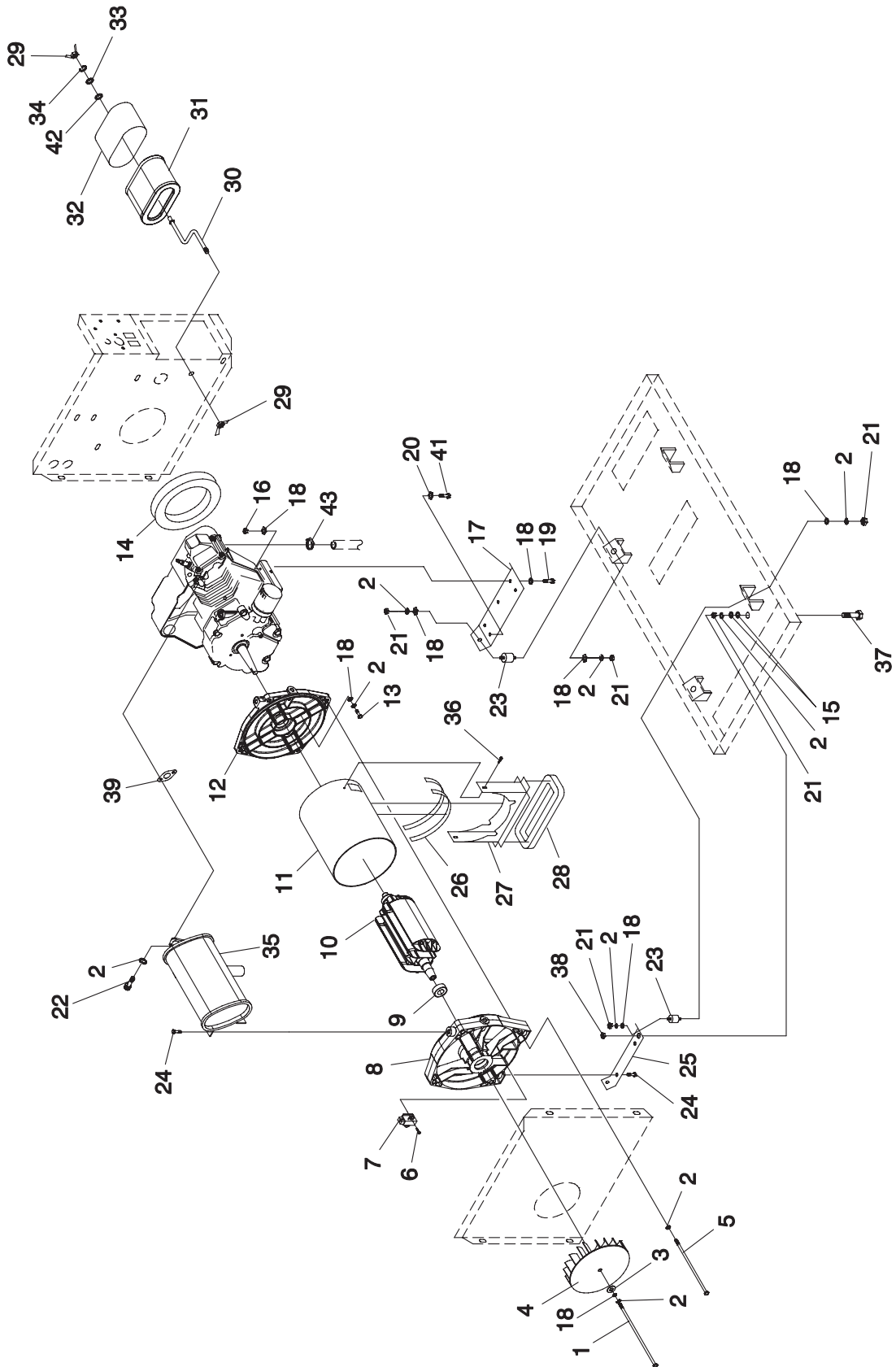

Section 7 – Exploded Views and Parts Lists

Recreational Vehicle Generator Generator – Drawing No. 0F4590-C

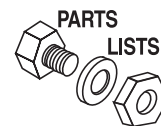

ITEM	PART NO.	QTY.	DESCRIPTION
1	029092	1	SCREW IHHC 5/16"-24 X 11-1/4" G5
2	022129	22	WASHER LOCK M8-5/16"
3	049451	1	WASHER FLAT .406" I.D. X 1.62" O.D.
4	0C8096A	1	FAN, 8" CURVE BLADE, 16.5MM I.D.
5	0D8120	4	SCREW IHHC M8-1.25 X 260MM
6	066849	2	SCREW HHTT M5-0.8 X 16
7	066386	1	ASSEMBLY, BRUSH HOLDER
8	0D4217	1	CARRIER, REAR BEARING
9	073159	1	BEARING
10	0D4484H	1	ROTOR
11	0D4430H	1	STATOR
12	0D4216	1	ADAPTOR, ENGINE
13	048614	4	SCREW HHC 5/16"-24 X 3/4"
14	0F9533	1	GASKET, FRONT DIVIDER
15	022131	4	WASHER FLAT 3/8"-M10
16	027028	4	NUT LOCK HEX 5/16"-18 NYLON INSERT
17	0D6832	1	BRACKET, ENGINE MOUNTING
18	022145	18	WASHER FLAT 5/16"
19	030231	3	SCREW HHC 5/16"-18 X 1-1/2"
20	0C3168	1	5/16" SPECIAL LOCK WASHER
21	022259	10	NUT HEX 5/16"-18
22	0C8565	2	SCREW SHC M8-1.25 X 18MM
23	0D8048	4	VIBRATION MOUNT
24	083512	6	SCREW HHTT M8-1.2 X 16MM
25	0D6831	1	BRACKET, ALTERNATOR MOUNTING
26	029451	2.14'	TAPE ELEC. UL FOAM 1/8" X 1/2"
27	0D6918	1	DUCT, ALTERNATOR AIR
28	0D2558	1	GASKET, ALTERNATOR DUCT
29	087680	2	NUT WING M6-1.0
30	0D7530	1	STUD, M6-1.0 OFFSET
31	0D9723	1	ELEMENT, AIR FILTER
32	0D4511	1	PRECLEANER, AIR
33	0D8451	1	WASHER FLAT .281" I.D. X 1.50" O.D.
34	022097	1	WASHER LOCK M6-1/4"
35	0G3671	1	MUFFLER
36	090388	2	SCREW HHTT M6-1.0 X 12MM
37	0G3671	2	BOLT CARR 5/16"-18 X 2"
38	081105	2	NUT FLANG 5/16"-18 LOCK
39	089476	1	GASKET, EXHAUST
41	022531	1	SCREW HHC 5/16"-18 X 1-3/4"
42	0D8981	1	FILTER GASKET RV
43	048031E	1	HOSE CLAMP 3/8"

Section 7 – Exploded Views and Parts Lists

**Recreational Vehicle Generator
Control Panel – Drawing No. 0F4591-A**

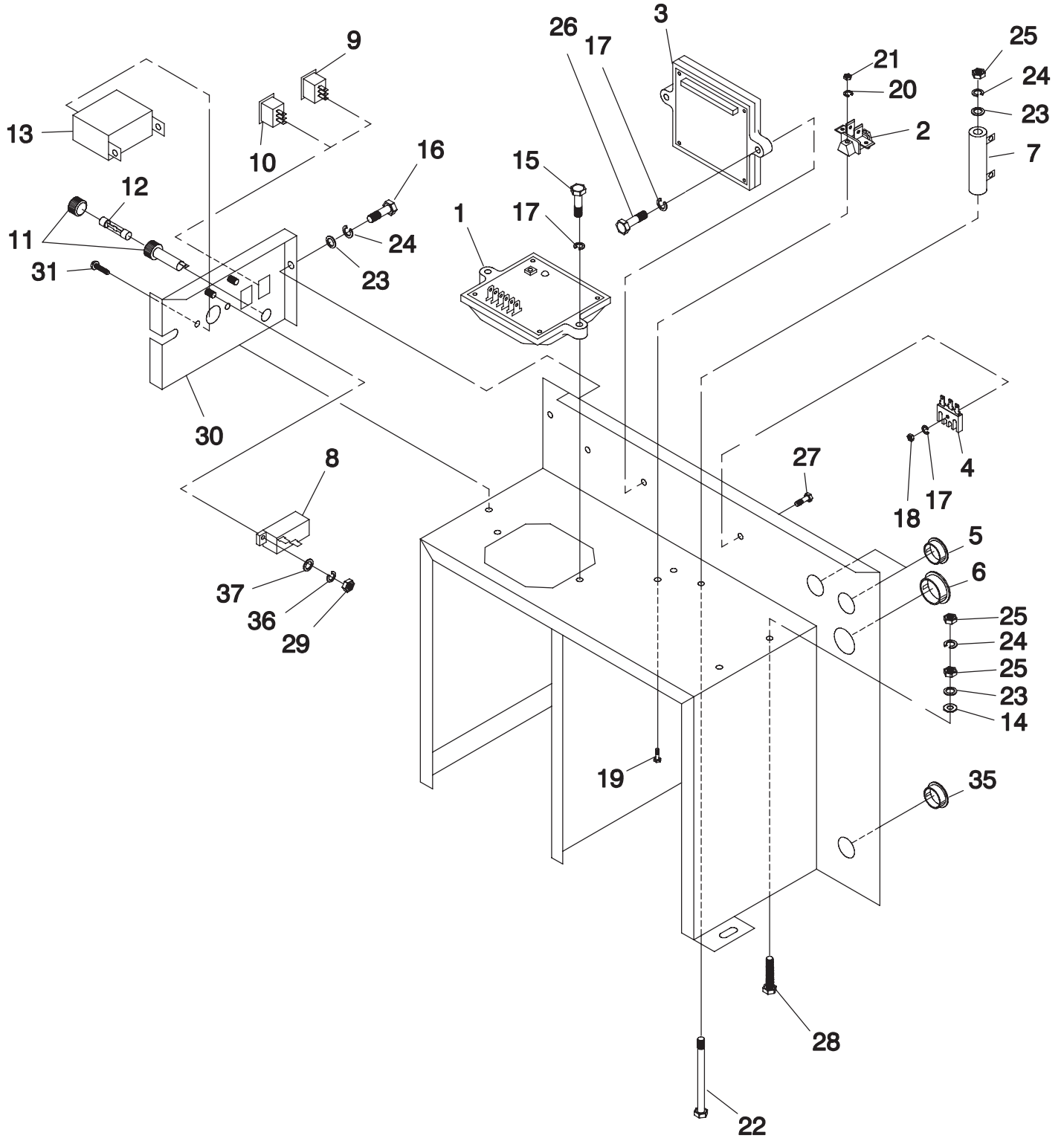

Section 7 – Exploded Views and Parts Lists

Recreational Vehicle Generator Control Panel – Drawing No. 0F4591-A

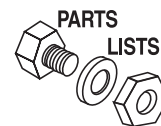

ITEM	PART NO.	QTY.	DESCRIPTION
1	0F9719	1	REGULATOR VOLTAGE
2	075210A	1	TERMINAL BLOCK
3	092234	1	CONTROLLER P.C.B.
4	065795	1	BATTERY CHARGER RECTIFIER
5	023484F	2	BUSHING SNAP 1"
6	023484R	1	BUSHING SNAP 1-1/4"
7	075234	1	RESISTOR, 1 OHM 25W
8	057159	1	CIRCUIT BREAKER 2.0 AMP (60HZ)
	054502	1	CIRCUIT BREAKER 3.0 AMP (50HZ)
9	087798	1	SWITCH S.P.D.T.
10	092113	1	SWITCH S.P.D.T. ON-MOM-ON
11	032300	1	HOLDER FUSE
12	0A9611	1	FUSE 7.5A
13	090145	1	CIRCUIT BREAKER, 30 X 1 (60HZ)
	0E2314	1	CIRCUIT BREAKER, 15A 2 POLE (50HZ)
14	0A1658	2	LOCK WASHER SPECIAL
15	075235	2	SCREW HHC M5-0.8 X 30MM
16	047411	2	SCREW HHC M6-1.0 X 16MM
17	049226	5	WASHER LOCK M5
18	051716	1	NUT HEX M5-0.8
19	075476	2	SCREW PPHM M4-0.7 X 16MM
20	022264	2	WASHER LOCK #8-M4
21	051715	4	NUT HEX M4-0.7
22	0A2053	1	SCREW HHC M6-1.0 X 65MM
23	022473	5	WASHER FLAT 1/4"
24	022097	4	WASHER LOCK M6-1/4"
25	049813	4	NUT HEX M6-1.0
26	055440	2	SCREW HHC M5-0.8 X 25MM
27	049815	1	SCREW HHC M5-0.8 X 16MM
28	038750	2	SCREW HHC M6-1.0 X 30MM
29	051714	2	NUT, HEX M3-0.5
30	0D8794	1	PANEL CONTROL
31	025105	2	SCREW RHM #6-32 X 1/4" SIMS
32	028739	2	TIE WRAP UL 4" (NOT SHOWN)
33	0D8308	1	DECAL (NOT SHOWN)
34	0F5025	1	HARNESS (NOT SHOWN)
35	023484S	1	BUSHING, SNAP 1.09"
36	043182	2	WASHER LOCK M3
37	031879	2	WASHER FLAT M3

Section 7 – Exploded Views and Parts Lists

**Recreational Vehicle Generator
GN-220 H/SH Engine – Drawing No. 0F5791-G Part 1**

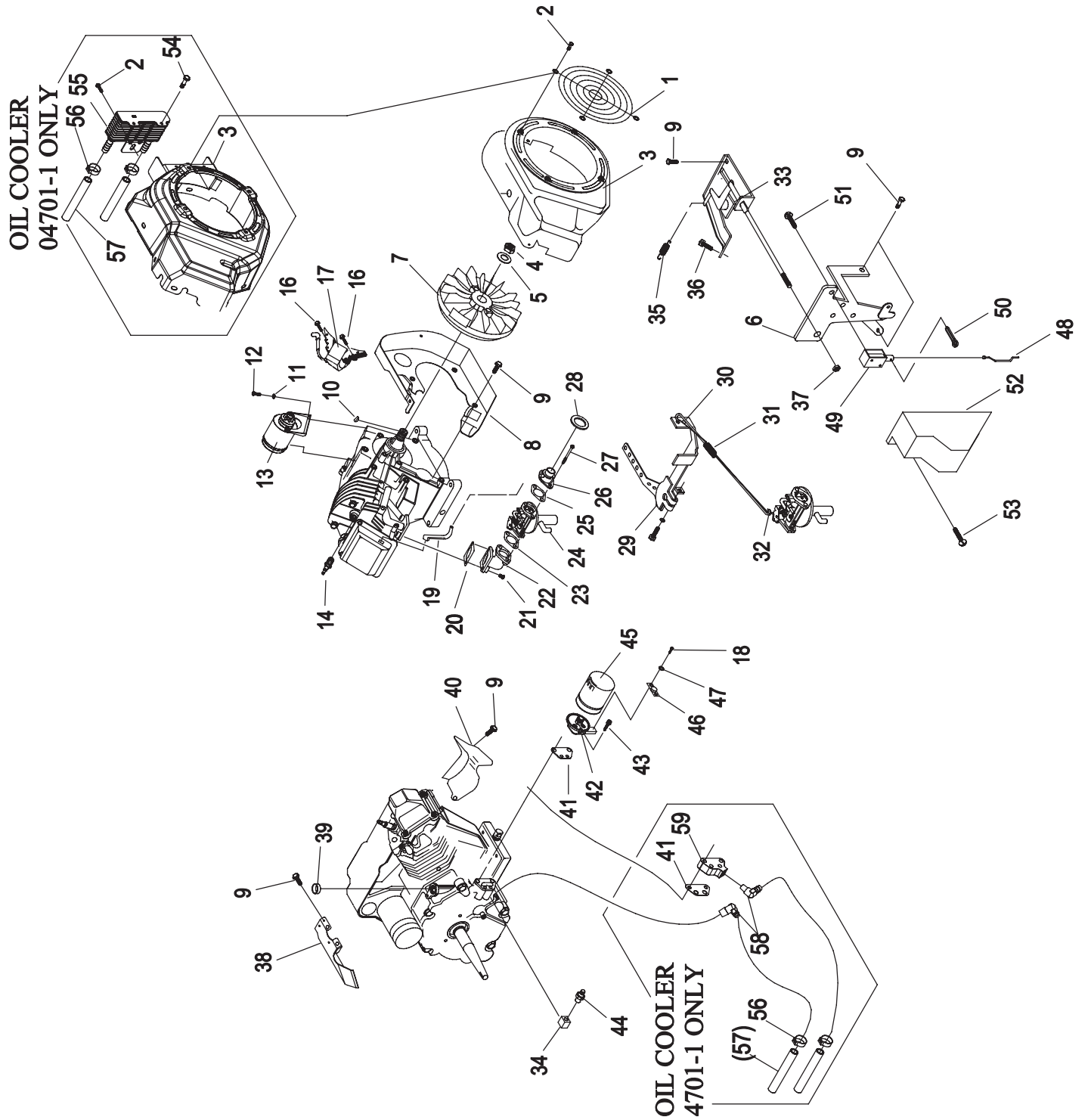

Section 7 – Exploded Views and Parts Lists

Recreational Vehicle Generator GN-220 H/SH Engine – Drawing No. 0F5791-G Part 1

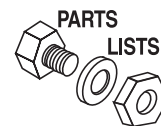

ITEM	PART NO.	QTY.	DESCRIPTION	ITEM	PART NO.	QTY.	DESCRIPTION
1	0D8433	1	GUARD, FAN	31	0C3979	1	SPRING, ANTI LASH
2	0C1069	10	SCREW, HHTT M6-1.0 X 8mm	32	085953	1	WASHER, CARB WEAR
		11	(04701-1 ONLY)	33	0D8739A	1	ASSEMBLY BRACKET GOVERNOR ADJUST
3	090695F	1	BLOWER HOUSING	34	0D9689	1	ELBOW 90D STREET 1/8NPT
	0G6468	1	BLOWER HOUSING (04701-1 ONLY)	35	0E7019	1	SPRING, GOVERNOR
4	081810	1	NUT, HEX M16-1.5	36	083512	1	SCREW HHTT M8-1.2 x 16mm
5	083312	1	WASHER, M16 CONICAL	37	082025	1	NUT HEX LOCK M5-0.8 NYLOCK
6	0D8400	1	ASSEMBLY, CHOKE SOLENOID BRACKET	38	092984	1	TOP WRAPPER
7	0C8917D	1	FLYWHEEL, WITH RING GEAR	39	094820	1	PLUG, EXPANSION
8	0C8798A	1	BACKPLATE, ELECTRIC START	40	089739	1	LOWER WRAPPER
9	045756	10	SCREW HHTT M6-1.0 X 10mm	41	091848	1	GASKET, OIL PSI PAD
10	082774	1	KEY, WOODRUFF 4 x 19D		091848	2	(04701-1 ONLY)
11	022129	2	5/16"-M8 LOCK WASHER	42	0D8778	1	ADAPTER, OIL FILTER
12	081990	2	SCREW SHC M8-1.25 X 40mm	43	0D8803	2	SCREW SHC M6-1.0 X 22mm
13	0D9004A	1	STARTER ASSEMBLY		040946	2	SCREW SHC M6-1.0 X 35MM G12.9
14	0E7585	1	SPARKPLUG				(04701-1 ONLY)
15				44	0D9235	1	SWITCH, OIL- 5 PSI
16	082981	2	TAPTITE, M6-1.0 x 30mm	45	070185B	1	FILTER, OIL
17	0G3231	1	ASSEMBLY, IGNITION COIL ADV. W/DIODE	46	0G6437	1	THERMAL SWITCH 305F
18	0C1085	2	SCREW PPHM M3-0.5 X 8mm	47	043182	2	WASHER LOCK M3
19	0D7666A	1	BREATHER TUBE	48	0D8397	1	ROD, CHOKE CONTROL
20	090051	1	GASKET, MANIFOLD/ HEAD	49	0D8591	1	SOLENOID, CHOKE
21	080316	2	SCREW HHFC M6-1.0 X 30mm	50	077091	1	PIN, COTTER
22	090948	1	INTAKE MANIFOLD	51	0A7095	2	SCREW PRHMS #4-40 x 1-1/8" LONG
23	078631	1	GASKET CARBURETOR/MANIFOLD	52	077075	1	COVER, CHOKE COIL
24	0F5759A	1	CARBURETOR LP WITH CHOKE NO IDLE PORT	53	0C2824	2	SCREW TAP-R #10-32 X 9/16"
25	091846	1	GASKET, CARB/ ADAPTOR	54	045764	2	SCREW HHTT M4-0.7 X 8 BP
26	0D7558	1	ADAPTOR, CARB	55	0E9406A	1	OIL COOLER 220
27	078643	2	BOLT, CARB MOUNT M6-1.0 x 75mm	56	0G3662	4	CLAMP, HOSE OETIKER STEPLESS 17
28	0D8372	1	GASKET, CARB TO AIRBOX	57	0G4695B	2	HOSE 3/8" X 16.25" BRAID-WRAP
29	0C2756	1	ASSEMBLY, GOVERNOR LEVER	58	0A6344	2	BARBED EL 90 1/8 NPT X 3/8
30	0D7458	1	ROD, GOVERNOR	59	0G6502	1	OIL FILTER SPACER 220RV

Section 7 – Exploded Views and Parts Lists

Recreational Vehicle Generator

GN-220 H/SH Engine – Drawing No. 0F5791-G Part 2

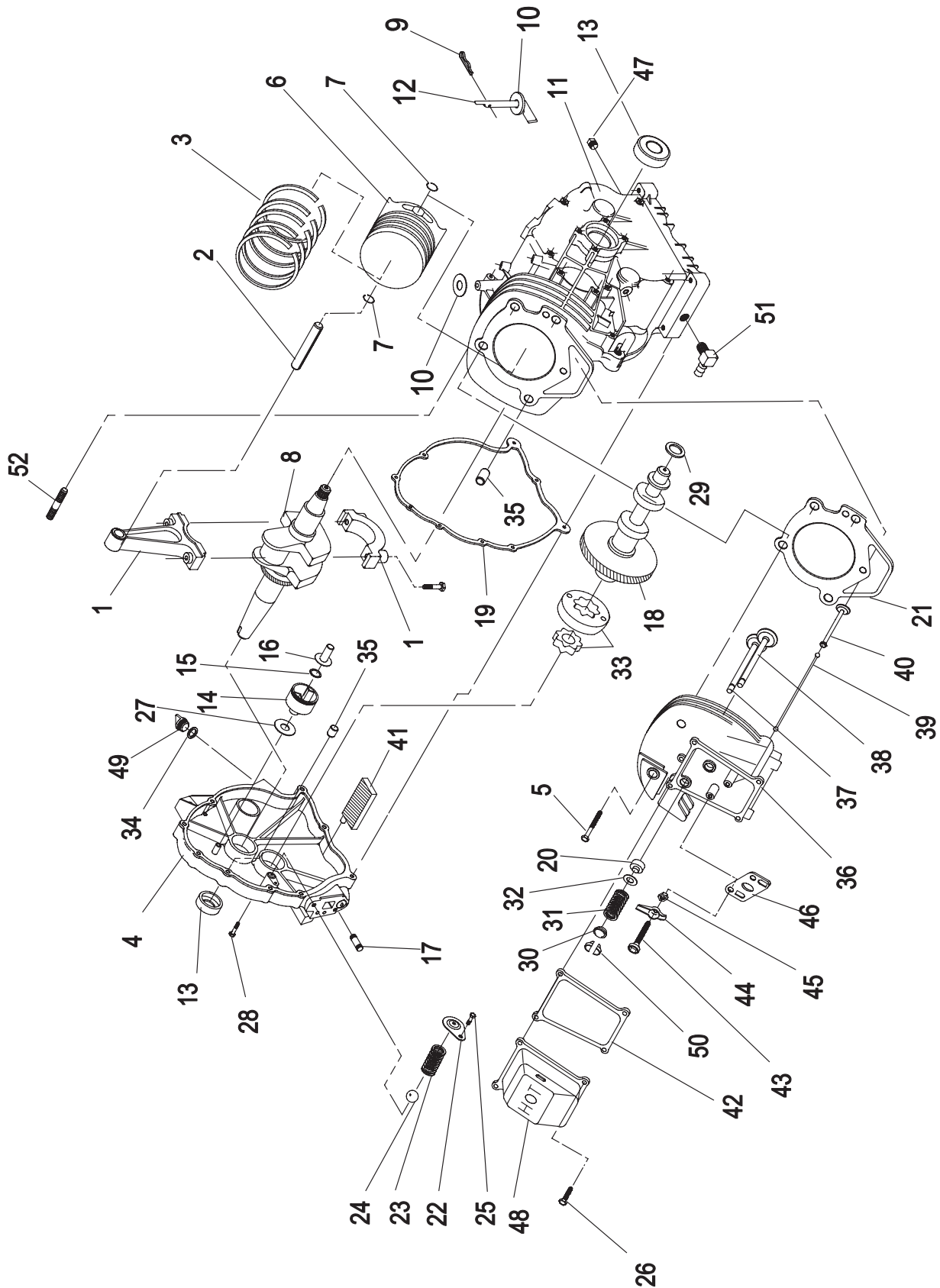

Section 7 – Exploded Views and Parts Lists
Recreational Vehicle Generator
GN-220 H/SH Engine – Drawing No. 0F5791-G Part 2

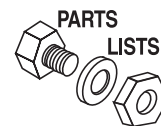

ITEM	PART NO.	QTY.	DESCRIPTION
N/A	0F5800	1	LONG BLOCK ASSEMBLY 220 RV LP
1	078621	1	CONNECTING ROD ASSEMBLY
2	076389	1	PISTON PIN
3	0G4379	1	RING SET, PISTON DIA 75
4	0A8897B	1	GEAR COVER ASSEMBLY
5	077168	5	M8 x 56mm HEAD BOLT
6	0G4331	1	PISTON, COATED DIA 75
7	076390	2	PIN RETAINER RING
8	0G5827	1	ASSY, CRANKSHAFT GH220 TAPER
9	078658	1	GOVERNOR "R" PIN
10	0F0967	2	WASHER FLAT 1/4, .015 THK
11	089213E	1	CRANKCASE ASSEMBLY
12	0A7637	1	GOVERNOR ARM
13	0E3811	2	OIL SEAL
14	0D1303	1	GOVERNOR GEAR ASSEMBLY
15	078645	1	GOVERNOR GEAR C-RING
16	0A7811	1	GOVERNOR SPOOL
17	072683A	1	1/8" NPT PIPE PLUG
18	0F0687	1	CAMSHAFT ASSEMBLY
19	089096	1	CRANKCASE GASKET
20	088156	1	VALVE STEM SEAL
21	0A8822	1	CYLINDER HEAD GASKET
22	078691	1	OIL PRESSURE RELIEF COVER
23	0A5772	1	OIL PRESSURE SPRING
24	0A5776	1	11/32" BALL
25	074908	1	M5 FORM SCREW
26	078606	4	M6-1.0 x 12mm SCREW
27	076361	1	GOVERNOR GEAR THRUST WASHER
28	0D2414	6	SCREW, HHFC M8-1.25 X 35mm
29	099922	1	SPRING WASHER
30	0C3733	2	VALVE RETAINER
31	0C4390	2	VALVE SPRING
32	084186	2	VALVE SPRING WEAR WASHER
33	083192	1	GEROTER SET
34	0E0057	1	"O" RING
35	078699B	4	SLEEVE, SEAM DWL
36	021705B	1	CYLINDER HEAD ASSEMBLY
37	0C3590	1	EXHAUST VALVE
38	0C3591	1	INTAKE VALVE
39	0D9853A	2	PUSH ROD
40	083235	2	TAPPET
41	080336	1	OIL PICK-UP ASSEMBLY
42	0C8754	1	ROCKER COVER GASKET
43	077161	2	PIVOT BALL STUD
44	077160	2	GN- 191/220 ROCKER ARM
45	076307	2	ROCKER ARM JAM NUT
46	088403	1	PUSH ROD GUIDE PLATE
47	026073A	1	1/4" NPT PIPE PLUG
48	088412A	1	ROCKER COVER ASSEMBLY
49	076329	1	PLASTIC OIL FILL PLUG
50	0C3592	4	VALVE SPRING KEEPER
51	049340	1	BARBED ELBOW 90 1/4" NPT X 3/8"
52	045761A	1	STUD M8-1.25 / 10mm X 30mm

Section 7 – Exploded Views and Parts Lists

Recreational Vehicle Generator Regulator – Drawing No. 0F5819

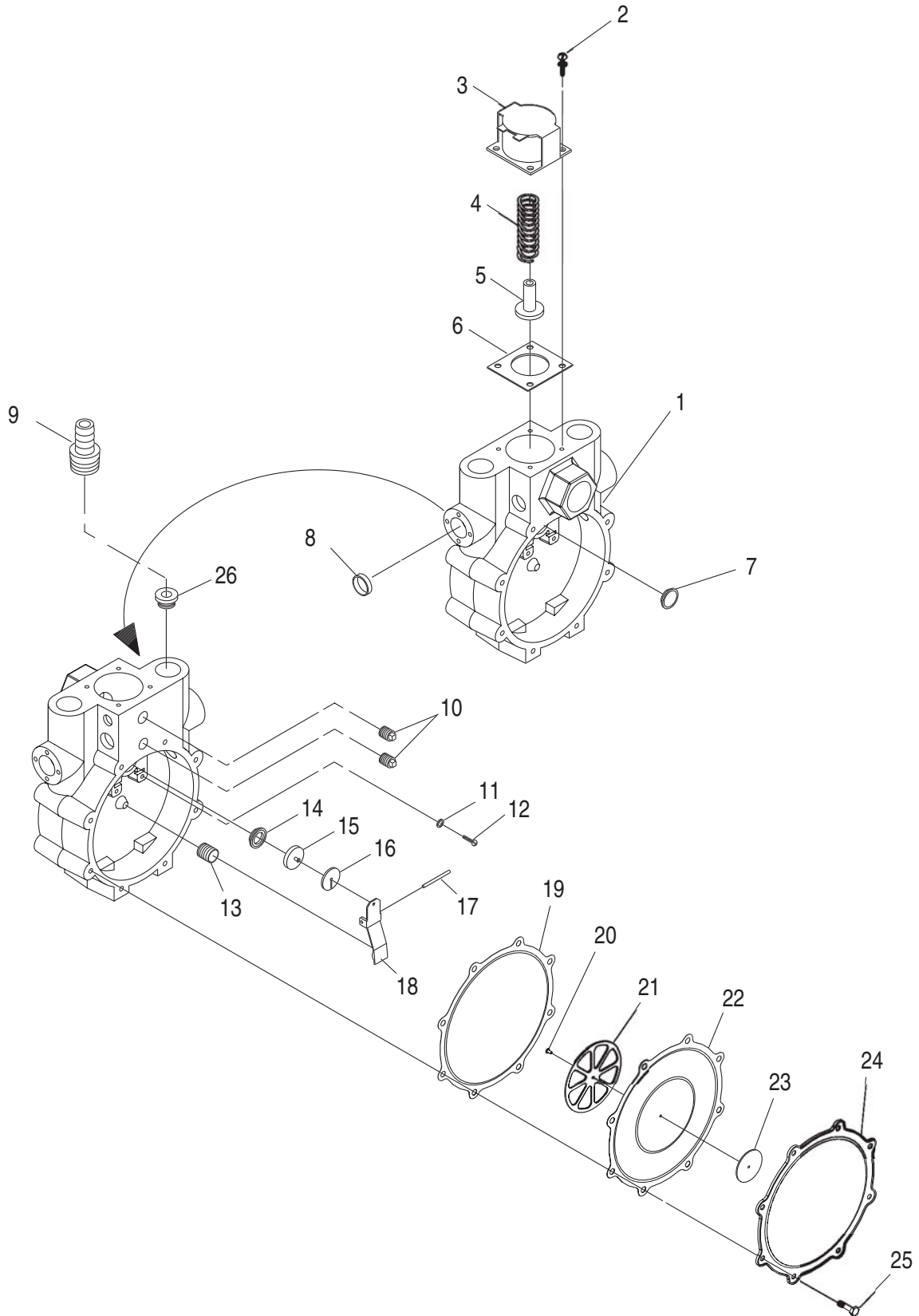

Section 7 – Exploded Views and Parts Lists

Recreational Vehicle Generator Regulator – Drawing No. 0F5819

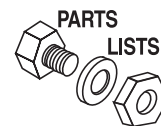

ITEM	PART NO.	QTY.	DESCRIPTION
1	0D5694	1	CASTING, TWIN REGULATOR HOUSING
2	0F4795	4	SCREW PPHM SEMS M4-0.7 X 10
3	0F5022	1	SOLENOID COIL, 12VDC
4	0C6070	1	SPRING-SOLENOID PLUNGER
5	0C4680	1	PLUNGER LP REG. ASSY
6	0C4647	1	GASKET, SOLENOID
7	0C4643	1	INLET, TWIN REGULATOR NO HOLE
8	0D3973	1	PLUG, EXPANSION 16MM TWINREG
9	0D7020A	1	BARBED STR 1/2NPT X 3/8" W/VS
10	026073	2	PLUG STD PIPE 1/8 STEEL SQ HD
11	0D3308	2	WASHER FLAT 3.2MM ID X 10MM OD
12	070728	2	SCREW PFILHM M3-0.5 X 5
13	0C5764	1	SPRING, REGULATOR
14	0C4643A	1	INLET, TWIN REG 11.11 DIA.
15	0C5764	1	SEAL, INLET REGULATOR
16	0C5968	1	SUPPORT, INLET SEAL
17	0C5759	1	PIN, PIVOT ARM
18	0C5761	1	LEVER, REGULATOR
19	0C6069	1	GASKET, DIAPHRAGM
20	0C6731	1	RIVET .118 X .125 ALUMINUM
21	0C6067	1	SUPPORT, DIAPHRAGM
22	0C4706	1	DIAPHRAGM, TWIN REGULATOR
23	0C6068	1	CAP, DIAPHRAGM SUPPORT
24	0C5762	1	COVER, TWIN REGULATOR
25	045764	8	SCREW HHTT M4-0.7 X 8 BP
26	0C5760K	1	JET LP



CALIFORNIA AND FEDERAL EMISSION CONTROL WARRANTY STATEMENT

YOUR WARRANTY RIGHTS AND OBLIGATIONS

The California Air Resources Board (CARB) and the United States Environmental Protection Agency (EPA), together with Generac Power Systems, Inc. (Generac), are pleased to explain the Emission Control System Warranty on your new engine.* New utility, and lawn and garden equipment engines must be designed, built and equipped to meet stringent anti-smog standards for the state of California and the federal government. Generac will warrant the emission control system on your engine for the periods of time listed below provided there has been no abuse, neglect, unapproved modification or improper maintenance of your engine.

Your emission control system may include parts such as the carburetor, ignition and exhaust systems. Generac will repair your engine at no cost to you for diagnosis, replacement parts and labor, should a warrantable condition occur.

MANUFACTURER'S EMISSION CONTROL SYSTEM WARRANTY COVERAGE:

Emissions control systems on 1997 and later model year engines are warranted for two years as hereinafter noted. If, during such warranty period, any emission-related component or system on your engine is found to be defective in materials or workmanship, repairs or replacement will be performed by a Generac Authorized Warranty Service Facility.

PURCHASER'S/OWNER'S WARRANTY RESPONSIBILITIES:

As the engine purchaser/owner, you are responsible for the completion of all required maintenance as listed in your factory supplied Owner's Manual. For warranty purposes, Generac recommends that you retain all receipts covering maintenance on your engine. However, Generac cannot deny warranty solely because of the lack of receipts or for your failure to ensure the completion of all scheduled maintenance.

As the engine purchaser/owner, you should, however, be aware that Generac may deny any and/or all warranty coverage or responsibility if your engine, or a part/component thereof, has failed due to abuse, neglect, improper maintenance or unapproved modifications, or the use of counterfeit and/or 'grey market' parts not made, supplied or approved by Generac.

You are responsible for presenting your engine to a Generac Authorized Warranty Service Facility as soon as a problem occurs. The warranty repairs should be completed in a reasonable amount of time, not to exceed 30 days.

Warranty service can be arranged by contacting either your selling dealer or a Generac Authorized Warranty Service Facility. To locate the Generac Authorized Warranty Service Facility nearest you, call our toll-free number:

1-800-333-1322

IMPORTANT NOTE: This warranty statement explains your rights and obligations under the Emission Control System Warranty (ECS Warranty), which is provided to you by Generac pursuant to California and federal law. See also the "Generac Limited Warranties for Generac Power Systems, Inc.," which is enclosed herewith on a separate sheet, also provided to you by Generac. The ECS Warranty applies only to the emission control system of your new engine. If there is any conflict in terms between the ECS Warranty and the Generac Warranty, the ECS Warranty shall apply except in circumstances where the Generac Warranty may provide a longer warranty period. Both the ECS Warranty and the Generac Warranty describe important rights and obligations with respect to your new engine.

Warranty service can be performed only by a Generac Authorized Warranty Service Facility. When requesting warranty service, evidence must be presented showing the date of the sale to the original purchaser/owner. The purchaser/owner shall be responsible for any expenses or other charges incurred for service calls and/or transportation of the product to/from the inspection or repair facilities. The purchaser/owner also shall be responsible for any and/or all damages or losses incurred while the engine is being transported/shipped for inspection or warranty repairs.

If you have any questions regarding your warranty rights and responsibilities, you should contact Generac at the following address:

**ATTENTION WARRANTY DEPARTMENT
GENERAC POWER SYSTEMS, INC.
P.O. BOX 297
WHITEWATER, WI 53190**



EMISSION CONTROL SYSTEM WARRANTY

Emission Control System Warranty (ECS Warranty) for 1997 and later model year engines:

- (a) Applicability: This warranty shall apply to 1997 and later model year engines. The ECS Warranty Period shall begin on the date the new engine or equipment is purchased by/delivered to its original, end-use purchaser/owner and shall continue for 24 consecutive months thereafter.
- (b) General Emissions Warranty Coverage: Generac warrants to the original, end-use purchaser/owner of the new engine or equipment, and to each subsequent purchaser/owner, that each of its engines is ...
- (1) Designed, built and equipped so as to conform with all applicable regulations adopted by the EPA and CARB pursuant to their respective authority, and
 - (2) Free from defects in materials and workmanship which, at any time during the ECS Warranty Period, may cause a warranted emissions-related part to fail to be identical in all material respects to the part as described in the engine manufacturer's application for certification.
- (c) The ECS Warranty only pertains to emissions-related parts on your engine, as follows:
- (1) Any warranted, emissions-related parts that are not scheduled for replacement as required maintenance in the Owner's Manual shall be warranted for the ECS Warranty Period. If any such part fails during the ECS Warranty Period, it shall be repaired or replaced by Generac according to Subsection (4) below. Any such part repaired or replaced under the ECS Warranty shall be warranted for the remainder of the ECS Warranty Period.
 - (2) Any warranted, emissions-related part that is scheduled only for regular inspection as specified in the Owner's Manual shall be warranted for the ECS Warranty Period. A statement in such written instructions to the effect of "repair or replace as necessary" shall not reduce the ECS Warranty Period. Any such part repaired or replaced under the ECS Warranty shall be warranted for the remainder of the ECS Warranty Period.
 - (3) Any warranted, emissions-related part that is scheduled for replacement as required maintenance in the Owner's Manual shall be warranted for the period of time prior to the first scheduled replacement point for that part. If the part fails prior to the first scheduled replacement, the part shall be repaired or replaced by Generac according to Subsection (4) below. Any such emissions-related part repaired or replaced under the ECS Warranty shall be warranted for the remainder of the ECS Warranty Period prior to the first scheduled replacement point for such emissions-related part.
 - (4) Repair or replacement of any warranted, emissions-related part under this ECS Warranty shall be performed at no charge to the owner at a Generac Authorized Warranty Service Facility.
 - (5) When the engine is inspected by a Generac Authorized Warranty Service Facility, the owner shall not be held responsible for diagnostic costs if the repair is deemed warrantable.
 - (6) Generac shall be liable for damages to other original engine components or approved modifications proximately caused by a failure under warranty of any emission-related part covered by the ECS Warranty.
 - (7) Throughout the ECS Warranty Period, Generac shall maintain a supply of warranted emission-related parts sufficient to meet the expected demand for such emission-related parts.
 - (8) Any Generac authorized and approved emission-related replacement part may be used in the performance of any ECS Warranty maintenance or repairs and will be provided without charge to the purchaser/owner. Such use shall not reduce Generac's ECS Warranty obligations.
 - (9) Unapproved, add-on, modified, counterfeit and/or 'grey market' parts may not be used to modify or repair a Generac engine. Such use voids this ECS Warranty and shall be sufficient grounds for disallowing an ECS Warranty claim. Generac shall not be held liable hereunder for failures of any warranted parts of a Generac engine caused by the use of such an unapproved, add-on, modified, counterfeit and/or 'grey market' part.

EMISSION RELATED PARTS INCLUDE THE FOLLOWING:

- | | |
|--|---|
| <p>1) Fuel Metering System:</p> <ol style="list-style-type: none">1.1) Gasoline carburetor assembly and its internal components (if so equipped).a) Fuel filter (if so equipped)b) Carburetor gasketsc) Fuel pump (if so equipped)1.2) LPG carburetion assembly and its internal components (if so equipped).a) Fuel controller (if so equipped)b) Mixer and its gaskets (if so equipped)c) Carburetor and its gaskets (if so equipped)d) Primary gas regulator (if so equipped)e) LP liquid vaporizer (if so equipped) | <p>2) Air Induction System including:</p> <ol style="list-style-type: none">a) Intake pipe/manifoldb) Air cleaner3) Ignition System including:a) Spark plugb) Ignition module4) Catalytic Muffler Assembly (if so equipped) including:a) Muffler gasketb) Exhaust manifold5) Crankcase Breather Assembly including:a) Breather connection tube |
|--|---|

*Generac engine types covered by this warranty statement include the following:

- 1) Utility
- 2) Lawn and Garden Equipment
- 3) Recreational Vehicle (RV) Generator
- 4) Industrial Mobile (IM) Generator



Section 8 – Warranty
Recreational Vehicle Generator

**GENERAC POWER SYSTEMS' THREE-YEAR LIMITED WARRANTY
FOR GUARDIAN RECREATIONAL VEHICLE GENERATORS**

NOTE: ALL UNITS MUST BE INSTALLED BY GENERAC POWER SYSTEMS AUTHORIZED SERVICE FACILITIES. For a period of 3 (three) years of operation from the date of original sale, Generac Power Systems, Inc. (Generac) will, at its option, repair or replace any part which, upon examination, inspection and testing by Generac or a Generac Authorized Warranty Service Facility, is found to be defective under normal use and service, in accordance with the warranty schedule set forth below. Any equipment that the purchaser/owner claims to be defective must be returned to and examined by the nearest Generac Authorized Warranty Service Facility. All transportation costs under the warranty, including return to the factory, are to be borne and prepaid by the purchaser/owner. This warranty applies only to Generac generators sold and rated for "Recreational Vehicle" (RV) applications, as Generac has defined Recreational Vehicle generator applications. The factory recommends exercising the unit one half-hour every month.

WARRANTY SCHEDULE – COMMERCIAL APPLICATIONS

YEAR ONE – 100% (one hundred percent) coverage on part(s), labor, removal and reinstallation listed:

- **Engine** – All components
- **Alternator** – All components

WARRANTY SCHEDULE – CONSUMER/PERSONAL APPLICATIONS

YEARS ONE AND TWO – 100% (one hundred percent) coverage on part(s), labor, removal and reinstallation listed:

- **Engine** – All components
- **Alternator** – All components

YEAR THREE – 100% (one hundred percent) only on selected part(s) and labor listed [Any labor and part(s) not listed, and removal and reinstallation are the owner's responsibility]:

- Rotor, Stator, Computer Control Board (part numbers 0A6060 and 0A3369) and inverter, (if applicable with regard to the generator) Cylinder Block, Cylinder Head, Crankshaft, Piston(s), Valve, Valve Lifter(s), Intake and Exhaust Manifolds

Generac RV generators manufactured prior to December 31, 1997, **DO NOT** have a transferable warranty. Generac RV generators manufactured after January 1, 1998, have a transferable warranty to the second owner **ONLY** for the remainder of the three-year limited warranty. Proof-of-purchase is required and must be presented to a Generac Authorized Warranty Service Facility prior to the performance of any warranty service.

All warranty expense allowances **are** subject to the conditions defined in Guardian's Warranty Policies and Procedures Guide.

THIS WARRANTY SHALL NOT APPLY TO THE FOLLOWING:

- Generac Guardian generators that utilize non-Generac replacement parts.
- Costs of normal maintenance, adjustments, installation and start-up.
- Repairs or diagnostics performed by individuals other than Guardian/Generac authorized dealers not authorized in writing by Generac Power Systems.
- Failures caused by any contaminated fuels, oils, coolants or lack of proper fluid amounts.
- Failures due, but not limited, to normal wear and tear, accident, misuse, abuse, negligence or improper installation. As with all mechanical devices, the Generac engines need periodic part(s) service and replacement to perform well. This warranty will not cover repair when normal use has exhausted the life of a part(s) or engine.
- Failures caused by any external cause or act of God, such as collision, theft, vandalism, riot or wars, nuclear holocaust, fire, freezing, lightning, earthquake, windstorm, hail, volcanic eruption, water or flood, tornado or hurricane.
- Damage related to rodent and/or insect infestation.
- Products that are modified or altered in a manner not authorized by Generac in writing.
- Any incidental, consequential or indirect damages caused by defects in materials or workmanship, or any delay in repair or replacement of the defective part(s).
- Failure due to misapplication.
- Telephone, cellular phone, facsimile, internet access or other communication expenses.
- Living or travel expenses of person(s) performing service, except as specifically included within the terms of a specific unit warranty period.
- Expenses related to "customer instruction" or troubleshooting where no manufacturing defect is found.
- Rental equipment used while warranty repairs are being performed.
- Overnight freight costs for replacement part(s).
- Overtime labor.
- Starting batteries, fuses, light bulbs and engine fluids.

THIS WARRANTY IS IN PLACE OF ALL OTHER WARRANTIES, EXPRESSED OR IMPLIED. SPECIFICALLY, GENERAC MAKES NO OTHER WARRANTIES AS TO THE MERCHANTABILITY OR FITNESS FOR A PARTICULAR PURPOSE. Some states do not allow limitations on how long an implied warranty lasts, so the above limitation may not apply to you.

GENERAC'S ONLY LIABILITY SHALL BE THE REPAIR OR REPLACEMENT OF PART(S) AS STATED ABOVE. IN NO EVENT SHALL GENERAC BE LIABLE FOR ANY INCIDENTAL OR CONSEQUENTIAL DAMAGES, EVEN IF SUCH DAMAGES ARE A DIRECT RESULT OF GENERAC'S NEGLIGENCE. Some states do not allow the exclusion or limitation of incidental or consequential damages, so the above limitation may not apply to you.

This warranty gives you specific legal rights. You also have other rights from state to state.

GENERAC® POWER SYSTEMS, INC.
P.O. BOX 297 • WHITEWATER, WI 53190

Revision 02.05