

SD150

Liquid Cooled Diesel Engine Generator Sets

Standby Power Rating
150KW 60 Hz / 150KVA 50 Hz

Prime Power Rating
120KW 60 Hz / 120KVA 50 Hz

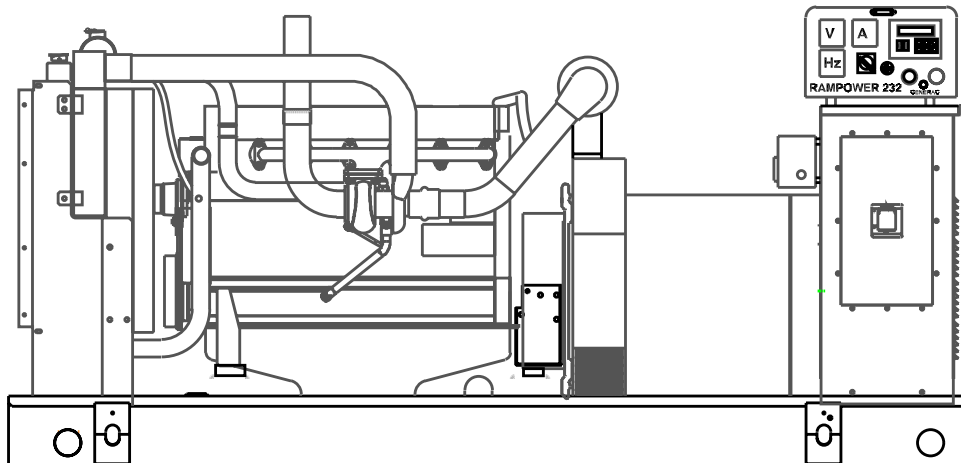

Power Matched
GENERAC 7.1DTA ENGINE
Turbo After Cooled

FEATURES

- **INNOVATIVE DESIGN & PROTOTYPE TESTING** are key components of GENERAC'S success in "IMPROVING POWER BY DESIGN." But it doesn't stop there. Total commitment to component testing, reliability testing, environmental testing, destruction and life testing, plus testing to applicable CSA, NEMA, EGSA, and other standards, allows you to choose GENERAC POWER SYSTEMS with the confidence that these systems will provide superior performance.
- **TEST CRITERIA:**
 - ✓ PROTOTYPE TESTED
 - ✓ SYSTEM TORSIONAL TESTED
 - ✓ ELECTRO-MAGNETIC INTERFERENCE
 - ✓ NEMA MG1 EVALUATION
 - ✓ MOTOR STARTING ABILITY
 - ✓ SHORT CIRCUIT TESTING
 - ✓ UL COMPLIANCE AVAILABLE
- **SOLID-STATE, FREQUENCY COMPENSATED VOLTAGE REGULATION.** This state-of-the-art power maximizing regulation system is standard on all Generac models. It provides optimized
- FAST RESPONSE to changing load conditions and MAXIMUM MOTOR STARTING CAPABILITY by electronically torque-matching the surge loads to the engine.
- **SINGLE SOURCE SERVICE RESPONSE** from Generac's dealer network provides parts and service know-how for the entire unit, from the engine to the smallest electronic component. You are never on your own when you own a GENERAC POWER SYSTEM.
- **ECONOMICAL DIESEL POWER.** Low cost operation due to modern diesel engine technology. Better fuel utilization plus lower cost per gallon provide real savings.
- **LONGER ENGINE LIFE.** Generac heavy-duty diesels provide long and reliable operating life.
- **GENERAC TRANSFER SWITCHES, SWITCHGEAR AND ACCESSORIES.** Long life and reliability is synonymous with GENERAC POWER SYSTEMS. One reason for this confidence is that the GENERAC product line includes its own transfer systems, accessories, switchgear and controls for total system compatibility.

GENERAC[®]
POWER SYSTEMS, INC.

APPLICATION & ENGINEERING DATA

SD150

GENERATOR SPECIFICATIONS

TYPE	Four-pole, revolving field
ROTOR INSULATION	Class H
STATOR INSULATION	Class H
TOTAL HARMONIC DISTORTION	<3%
TELEPHONE INTERFERENCE FACTOR (TIF)	<50
ALTERNATOR	Self-ventilated and drip-proof
BEARINGS (PRE-LUBED & SEALED)	1
COUPLING	Direct, Flexible Disc
LOAD CAPACITY (STANDBY)	100%
LOAD CAPACITY (PRIME)	110%

NOTE: Emergency loading in compliance with NFPA 99, NFPA 110, paragraph 5-13.2.6. Generator rating and performance in accordance with ISO8528-5, BS5514, SAE J1349, ISO3046 and DIN6271 standards.

EXCITATION SYSTEM

- PERMANENT MAGNET EXCITER Eighteen pole exciter ✓
 - Magnetically coupled DC current ✓
 - Mounted outboard of main bearing ✓
- REGULATION
- Solid-state ✓
- ±1% regulation ✓

GENERATOR FEATURES

- Four pole, revolving field generator, directly connected to the engine shaft through a heavy-duty, flexible disc for permanent alignment.
- Generator meets the temperature rise standards for class "F" insulation as defined by NEMA MG1-32.6, while the insulation system meets the requirements for the higher class "H" rating.
- All prototype models have passed a three-phase symmetrical short circuit test to assure system protection and reliability.
- All prototype models are tested for motor starting ability by measuring the instantaneous voltage dip with a waveform data acquisition system.
- All models utilize an advanced wire harness design for reliable interconnection within the circuitry.
- Magnetic circuit, including amortisseur windings, tooth and skewed stator design, provides a minimal level of waveform distortion and an electromagnetic interference level which meets accepted requirements for standard AM radio, TV, and marine radio telephone applications.
- Voltage waveform deviation, total harmonic content of the AC waveform, and T.I.F. (Telephone Influence Factor) have been evaluated to acceptable standards in accordance with NEMA MG1-32.
- Alternator is self-ventilated and drip-proof constructed.
- Fully life-tested protective systems, including "field circuit and thermal overload protection" and optional main-line circuit breakers capable of handling full output capacity.
- System Torsional acceptability confirmed during Prototype Testing.

ENGINE SPECIFICATIONS

MAKE	GENERAC/DEUTZ
MODEL	BF6M1013FC Deutz
CYLINDERS	6
DISPLACEMENT	7.1 Liter (433 cu.in.)
BORE	108 mm (4.25 in.)
STROKE	130 mm (5.12 in.)
COMPRESSION RATIO	17.6:1
INTAKE AIR	Turbocharged/Aftercooled
NUMBER OF MAIN BEARINGS	7
CONNECTING RODS	Drop Forged Steel
CYLINDER HEAD	Cast Iron
PISTONS	Aluminum Alloy
CRANKSHAFT	Die Forged, Induction Hardened Steel

VALVE TRAIN

LIFTER TYPE	Solid
INTAKE VALVE MATERIAL	Heat Resistant Steel
EXHAUST VALVE MATERIAL	Heat Resistant Steel
HARDENED VALVE SEATS	Replaceable

ENGINE GOVERNOR

- ELECTRONIC
- Standard
- FREQUENCY REGULATION, NO-LOAD TO FULL LOAD ... 0.5%
- STEADY STATE REGULATION
- 0.25%

LUBRICATION SYSTEM

TYPE OF OIL PUMP	Gear
OIL FILTER	Full flow, Cartridge
CRANKCASE CAPACITY	21 Liters (22.2 qts.)

COOLING SYSTEM

TYPE OF SYSTEM	Pressurized, Closed Recovery
WATER PUMP	Pre-Lubed, Self-Sealing
TYPE OF FAN	Pusher
NUMBER OF FAN BLADES	6
DIAMETER OF FAN	660 mm (26 in.)
COOLANT HEATER	120V, 1800 W

FUEL SYSTEM

FUEL	#2D Fuel (Min Cetane #40)
	(Fuel should conform to ASTM Spec.)
FUEL FILTER	5 Micron
FUEL INJECTION PUMP	Bosch, Unit type cam driven
FUEL PUMP	Mechanical
INJECTORS	Multi-Hole, Nozzle Type
ENGINE TYPE	Direct Injection
FUEL LINE (Supply)	6.35 mm (0.25 in.)
FUEL RETURN LINE	6.35 mm (0.25 in.)

ELECTRICAL SYSTEM

BATTERY CHARGE ALTERNATOR	20 Amps at 12 V
STARTER MOTOR	12 V
RECOMMENDED BATTERY	12 Volt, 90 A.H., 27F
GROUND POLARITY	Negative

SD150

OPERATING DATA

	STANDBY				PRIME				
	SD150				SD150				
GENERATOR OUTPUT VOLTAGE/KW-60Hz	Rated AMP				Rated AMP				
120/240V, 1-phase, 1.0 pf	150			625	120			500	
120/208V, 3-phase, 0.8 pf	150			520	120			416	
120/240V, 3-phase, 0.8 pf	150			451	120			361	
277/480V, 3-phase, 0.8 pf	150			226	120			180	
600V, 3-phase, 0.8 pf	150			180	120			144	
	NOTE: Consult your Generac dealer for additional voltages.								
GENERATOR OUTPUT VOLTAGE/KVA-50Hz	Rated AMP				Rated AMP				
110/220V, 1-phase, 1.0 pf	120			545	96			436	
115/200V, 3-phase, 0.8 pf	150			433	120			346	
100/200V, 3-phase, 0.8 pf	150			433	120			346	
231/400V, 3-phase, 0.8 pf	150			217	120			173	
480V, 3-phase, 0.8 pf	150			180	120			144	
	NOTE: Consult your Generac dealer for additional voltage								
MOTOR STARTING KVA									
Maximum at 35% instantaneous voltage dip with standard alternator; 50/60 Hz	231/240V		400/480V		231/240V		400/480V		
	390		405		390		405		
with optional alternator; 50/60 Hz	325		338		325		338		
FUEL									
Fuel consumption—60 Hz	Load	25%	50%	75%	100%	25%	50%	75%	100%
	liters/hr.	9.3	17.3	25.1	32.6	7.4	13.8	20.1	26.0
	gal./hr.	2.5	4.6	6.6	8.6	2.0	3.6	5.3	6.9
Fuel consumption—50 Hz	liters/hr.	7.4	13.8	20.1	26.0	5.9	11.0	16.0	20.8
	gal./hr.	2.0	3.6	5.3	6.9	1.6	2.9	4.2	5.5
COOLING									
Coolant capacity	System - lit. (gal)	19.0 (5.0)			19.0 (5.0)				
	Engine - lit. (gal)	9.8 (2.6)			9.8 (2.6)				
	Radiator - lit. (gal)	9.2 (2.4)			9.2 (2.4)				
Coolant flow/min.	60 Hz - lit. (gal)	159.0 (42.0)			159.0 (42.0)				
	50 Hz - lit. (gal)	132.5 (35.0)			132.5 (35.0)				
Heat rejection to coolant @ full load	BTU/hr.	344,700			275,760				
Air to radiator in	60 Hz - m ³ /min. (cfm)	159 (5,600)			159 (5,600)				
enclosed unit	50 Hz - m ³ /min. (cfm)	132 (4,667)			132 (4,667)				
Max. external pressure drop on radiator	in. H ₂ O	0.5			0.5				
Max. air temperature to radiator	°C (°F)	48.9 (120)			48.9 (120)				
Max. ambient temperature	°C (°F)	43.3 (110)			43.3 (110)				
COMBUSTION AIR REQUIREMENTS									
Flow at rated power	60 Hz - m ³ /min. (cfm)	14.2 (501.0)			11.3 (400.8)				
	50 Hz - m ³ /min. (cfm)	11.3 (398.9)			9.0 (319.2)				
EXHAUST									
Exhaust flow at rated output	60 Hz - m ³ /min. (cfm)	38.6 (1362)			30.9 (1090)				
	50 Hz - m ³ /min. (cfm)	30.7 (1085)			24.6 (868)				
Max recommended back pressure	in. Hg (kPa)	5.1 (1.5)			5.1 (1.5)				
Exhaust temperature at rated output	°C (°F)	538 (1000)			538 (1000)				
Exhaust outlet size	mm. (in.)	127 (5.0)			127 (5.0)				
ENGINE									
Rated RPM	60 Hz / 50 Hz	1800 / 1500			1800 / 1500				
HP at rated KW	60 Hz / 50 Hz	221 / 176			178 / 141				
Piston speed	60 Hz - m./sec. (ft./min.)	7.8 (1535)			7.8 (1535)				
	50 Hz - m./sec. (ft./min.)	6.5 (1280)			6.5 (1280)				
BMEP	60 Hz / 50 Hz - psi	223 / 213			180 / 171				
DERATION FACTORS									
Temperature									
	-3.5% for every 10°C above - °C	40			40				
	-2.77% for every 10°F above - °F	104			104				
Altitude									
	-1.1% for every 100 m above - m	1066			1066				
	-3.5% for every 1000 ft. above - ft.	3500			3500				

STANDARD ENGINE & SAFETY FEATURES

SD150

- High Coolant Temperature Automatic Shutdown
- Low Coolant Level Automatic Shutdown
- Low Oil Pressure Automatic Shutdown
- Overspeed Automatic Shutdown (Solid-state)
- Crank Limiter (Solid-state)
- Oil Drain Extension
- Radiator Drain Extension
- Factory-Installed Cool Flow Radiator
- Closed Coolant Recovery System
- UV/Ozone Resistant Hoses
- Rubber-Booted Engine Electrical Connections
- Coolant Heater
- Secondary Fuel Filter
- Fuel Lockoff Solenoid
- Stainless Steel Flexible Exhaust Connection
- Battery Charge Alternator
- Battery Cables
- Battery Tray
- Vibration Isolation of Unit to Mounting Base
- 12 Volt, Solenoid-activated Starter Motor
- Air Cleaner
- Fan Guard
- Control Console
- Radiator Duct Adaptor

OPTIONS

- **OPTIONAL COOLING SYSTEM ACCESSORIES**
 - 208/240V Coolant Heater
- **OPTIONAL FUEL ACCESSORIES**
 - Flexible Fuel Lines
 - UL Listed Fuel Tanks
 - Base Tank Low Fuel Alarm
 - Primary Fuel Filters
- **OPTIONAL EXHAUST ACCESSORIES**
 - Critical Exhaust Silencer
- **OPTIONAL ELECTRICAL ACCESSORIES**
 - 2A Battery Charger
 - 10A Dual Rate Battery Charger
 - Battery, 12 Volt, 135 A.H.
- **OPTIONAL ALTERNATOR ACCESSORIES**
 - Alternator Upsizing
 - Alternator Strip Heater
 - Alternator Tropicalization
 - Voltage Changeover Switch
 - Main Line Circuit Breaker
- **CONTROL CONSOLE OPTIONS**
 - Analog Control "C" Panel (Bulletin 0151160SBY)
 - Analog/Digital Control "E" Panel (Bulletin 0161310SBY)
- **ADDITIONAL OPTIONAL EQUIPMENT**
 - Automatic Transfer Switch
 - Isochronous Governor
 - 3 Light Remote Annunciator
 - 5 Light Remote Annunciator
 - 20 Light Remote Annunciator
 - Remote Relay Panels
 - Unit Vibration Isolators
 - Oil Make-Up System
 - Oil Heater
 - 5 Year Warranties
 - Export Boxing
 - GenLink® Communications Software
- **OPTIONAL ENCLOSURE**
 - Weather Protective
 - Sound Attenuated
 - Aluminum and Stainless Steel
 - Enclosed Muffler

Distributed by:

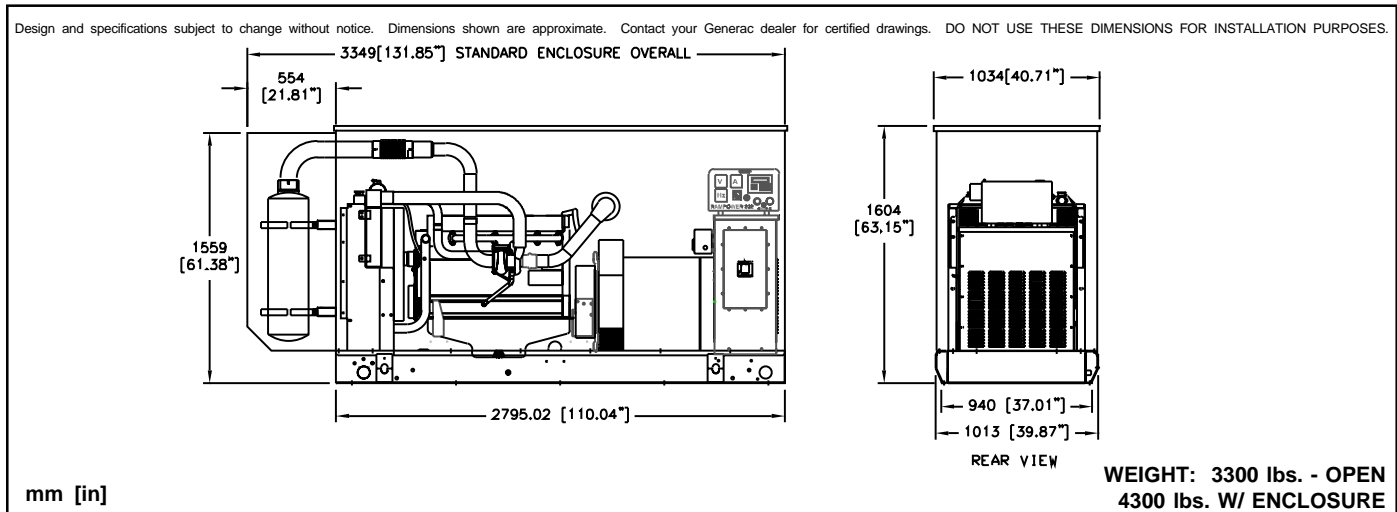

GENERAC® POWER SYSTEMS, INC. • P.O. BOX 8 • WAUKESHA, WI 53187

262/544-4811 • FAX 262/544-4851