

## V5 Node B Installation Guide

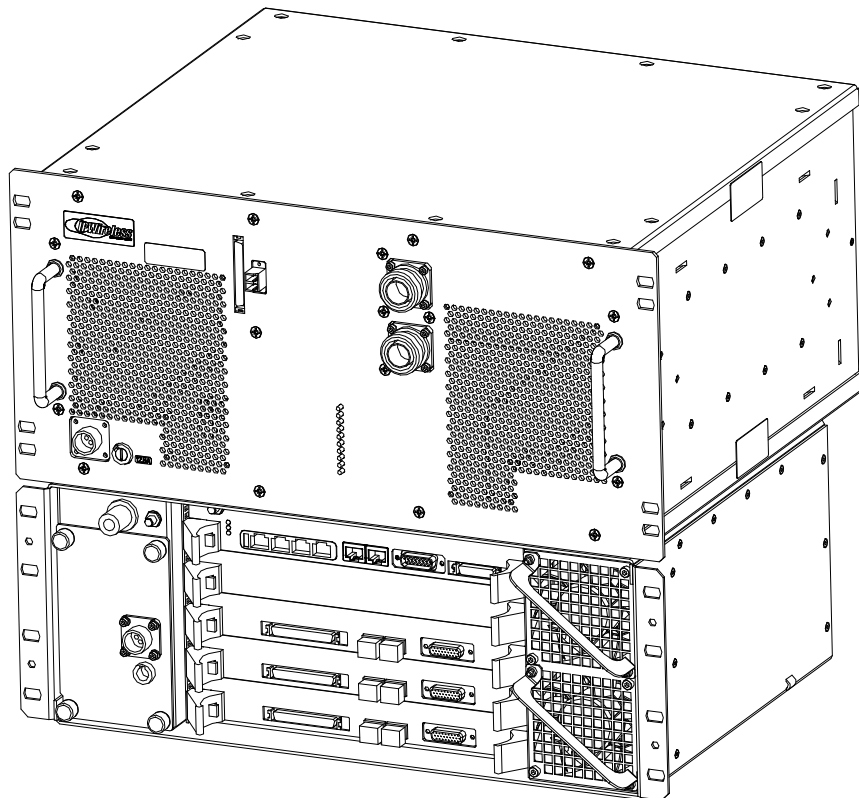

**Information in this document and the products described are subject to change without notice.**

**©2000-2007 IPWireless, Inc. All rights reserved.**

Reproduction, alteration, or distribution in any manner whatsoever without the written permission of IPWireless Inc, is strictly forbidden.

Trademarks used in this text: the IPWireless logo, icon and IPWireless Broadband Modem are trademarks of IPWireless, Inc.; Microsoft, Windows, and Windows NT are registered trademarks of Microsoft Corporation.

Other trademarks and trade names may be used in this document to refer to either the entities claiming the marks and names or their products, IPWireless, Inc., disclaims any proprietary interest in trademarks and trade names other than its own.

**February 2010**

**Part No. IPW-1442**

### WEEE Compliance



In compliance with the requirements for marking electrical and electronic equipment as directed in article 11 (2) of Directive 2002/96/EC, Waste from Electrical and Electronic Equipment (WEEE), IPWireless applies a crossed-out bin symbol to all Node B products.

The mark signifies that the IPWireless equipment is to be reprocessed or recycled using IPWireless authorized recyclers and processes.

This minimizes the disposal of unsorted municipal waste, achieves a high level of separate collection of WEEE, and ensures the environmentally sound disposal of electrical and electronic equipment placed on the market after 13 August 2005.

To dispose of equipment marked with the WEEE symbol, IPWireless has contracted with certified companies that can reprocess this equipment per European Union requirements.

To find out further information regarding disposal of IPWireless equipment within the EU visit the IPWireless web site, [ipwireless.com](http://ipwireless.com), or contact your IPWireless representative.

**Contents**

<b>1. Release Version .....</b>	<b>6</b>
<b>2. Safety Precautions .....</b>	<b>7</b>
<b>3. General Warnings .....</b>	<b>7</b>
<b>4. Overview.....</b>	<b>9</b>
<b>5. General Specifications .....</b>	<b>10</b>
<b>6. Installation.....</b>	<b>15</b>
<b>Step 1 Pre-Installation .....</b>	<b>15</b>
<b>Step 2 Parts Shipped &amp; Tools Required .....</b>	<b>16</b>
<b>Step 3 Site Preparations for Node B Installation .....</b>	<b>20</b>
<b>Step 4 Mounting Installations.....</b>	<b>24</b>
<b>Step 5 Ground Installation .....</b>	<b>27</b>
<b>Step 6 DC Power Connection-Control Shelf .....</b>	<b>28</b>
<b>Step 7 DC Power Connection-Radio Equipment Shelf.....</b>	<b>29</b>
<b>Step 8 Inter-Shelf Connections .....</b>	<b>30</b>
<b>Step 9 Backhaul Connections (lub) to INC.....</b>	<b>32</b>
<b>Step 9 Backhaul Connections (lub) to INC.....</b>	<b>32</b>
<b>Step 10 Antenna Cabling - Installation .....</b>	<b>35</b>
<b>Step 11 Alarm Connections .....</b>	<b>36</b>
<b>Step 12 GPS Installation &amp; Operation.....</b>	<b>38</b>
<b>Step 13 TTLNA Interfaces .....</b>	<b>40</b>
<b>7. APPENDIX .....</b>	<b>41</b>
<b>Appendix A - Installation Check Card.....</b>	<b>41</b>
<b>Appendix B – Glossary .....</b>	<b>42</b>

## Tables

Table 2-1 : Safety Symbols .....	7
Table 5-1 : Specifications .....	10
Table 5-2 : Node B Model Types .....	12
Table 6-1 : Control Shelf - Packing List.....	17
Table 6-2 : Radio Equipment Shelf - Packing List.....	18
Table 6-3 : Tools Required.....	19
Table 6-4 : Materials Required.....	19
Table 6-5 : Site Preparation Checklist .....	20
Table 6-6 : Ethernet Pin-outs using RJ45 .....	33
Table 6-7 : T1/E1 Pin-outs (RJ48C) .....	34
Table 6-8 : Alarm Inputs & Outputs .....	37

## Figures



Figure 5-1 : Node B Rack Mount – Control Shelf Physical Dimensions .....	11
Figure 5-2 : Node B Rack Mount – Radio Equipment Physical Dimensions .....	11
Figure 5-3 : General Description – Front View .....	12
Figure 5-4 : Control Shelf Faceplate (dims mm).....	13
Figure 5-5 : Radio Equipment Shelf Faceplate .....	14
Figure 6-1 : Control Shelf Package + Contents .....	17
Figure 6-2 : Radio Equipment Shelf Package + Contents .....	18
Figure 6-3 : Node B Rack Mount – Single Support Shelf (all cables shown) .....	21
Figure 6-4 : V5C Node B Rack Mount – Alternative Stack-ups .....	22
Figure 6-5 : Mounting Rack + Support Shelves/Rails .....	24
Figure 6-6: Installing Control Shelf.....	25
Figure 6-7 : Installing Radio Equipment Shelf.....	26
Figure 6-8 : Earth Connection on the rear of each shelf .....	27
Figure 6-9 : Power Connection to the Control shelf .....	28
Figure 6-10 : Power Connection to the Radio Equipment shelf .....	29
Figure 6-11: Interface MMF Cable Connection .....	30
Figure 6-12: Interface Cable Connection – V5C .....	31
Figure 6-13 : Backhaul Connections .....	32
Figure 6-14 : Ethernet Pin-outs using RJ45.....	33
Figure 6-15 : Antenna Connections & Routing.....	35
Figure 6-16 : Alarm Outputs & Inputs.....	36
Figure 6-17 : GPS Antenna .....	38
Figure 6-18 : GPS Antenna Connection .....	39
Figure 6-19 : TTLNA Connections.....	40

## 1. Release Version

<b>Date</b>	<b>Version</b>	<b>Author</b>	<b>Reason For Change Issue</b>
23rd January 2007	1.0.0	L. Mujegu	First Issue
05 <sup>th</sup> March 2007	1.0.1	L. Mujegu	Additional specs on optical i/f
8 <sup>th</sup> March 2007	1.0.2	L. Mujegu	Minor typo corrections
10 <sup>th</sup> July 2007	1.0.3	P Warburg	Safety Update
10 <sup>th</sup> August 2007	1.0.4	P Warburg	FCC Regulatory Information added
29 <sup>th</sup> January 2010	1.0.5	P Warburg	FCC Regulatory Information added
4 <sup>th</sup> February 2010	1.0.6	P Warburg	FCC Regulatory Information added

## 2. Safety Precautions

**Table 2-1 : Safety Symbols**

GENERAL WARNING	ELECTRICAL HAZARD	GROUND
		
<p><b>GENERAL SAFETY PRECAUTION</b></p>	<p><b>VOLTAGE:</b> Care should be taken when servicing this area. Misuse or inappropriate contact with these areas could result in physical harm and property damage</p>	<p><b>GROUND:</b> Site for grounding equipment</p>

These cautionary signs are used on the equipment and within this manual. For safety of personnel and protection of equipment observe these precautions when installing, operating or servicing the equipment and surrounding areas.

## 3. General Warnings

### Electrical

**Power Supply** – the power cords supplied are for DC. DO NOT adapt to a different configuration.

Power supply circuits may carry high voltages. Remove rings, watches, and other jewellery before working with this type of equipment.

**Batteries** – Certain installation of this equipment may require working with lead acid batteries, batteries present chemical, electric and gaseous hazards. Batteries are not supplied by IPWireless for the Node B equipment although UPS systems may be coupled with the Node B equipment in order to provide back up power in case of power outages.

### Physical

**Weight** –The Radio Equipment or Control shelves of the Rack Node B can weigh up to 25kgs (55 pounds) each depending on configurations. Precautions should be taken, depending on the installation site conditions, in lifting and general handling the device.

### Environmental

There are different precautions to take within each installation situation. Specific precautions are listed in the installation section for that situation.

### Site Location

The Node B Rack Mount basestation is designed to be installed in restricted access locations only. The site locations are accessible by suitably trained service/installation personnel only.

### Network Connections

The Node B Rack Mount basestation is NOT suitable for direct connection to Public Switched Networks. This means that the Node B is NOT suitable for direct connection to TNV circuits.

**FCC Regulatory Information**

This device complies with Part 15 of the FCC Rules. Operation is subject to the following two conditions: (1) this device may not cause harmful interference, and (2) this device must accept any interference received, including interference that may cause undesired operation.

No changes shall be made to the equipment without the manufacturer's permission as this may void the user's authority to operate the equipment.

To comply with FCC requirements, the V5 Node B has been approved for use with antennae that have a maximum gain of 20dBi.

To comply with the FCC RF exposure rules, see relevant section.

The 2.5GHz V5 Node B has been evaluated against the Maximum Permissible Exposure (MPE) limits defined in Section 1.1310 of the FCC rules for the uncontrolled environment. During normal operation, all persons should maintain a distance of at least 1.64m from the antenna for operation at 7.68Mcps and at least 2.31m from the antenna for operation at 3.84Mcps to ensure compliance with the MPE limits.

The 2.3GHz V5 Node B has been evaluated against the Maximum Permissible Exposure (MPE) limits defined in Section 1.1310 of the FCC rules for the uncontrolled environment. During normal operation, all persons should maintain a distance of at least 2.83m from the antenna to ensure compliance with the MPE limits.

The 700MHz V5 Node B has been evaluated against the Maximum Permissible Exposure (MPE) limits defined in Section 1.1310 of the FCC rules for the uncontrolled environment. During normal operation, all persons should maintain a distance of at least 4.06m from the antenna to ensure compliance with the MPE limits.



## Overview

Node B is the European Technical Standards Institute's (ETSI) name for the radio base station. The basic function of the Node B is to convert 100 BaseT, E1/T1 or E3/T3 into the UTRAN TD-CDMA air interface used between the Node B and the 3G Modem. One V5 Node B can provide up to 3 sectors of RF coverage (V5C) and can also be configured to operate in a pseudo-sectored mode using splitters (V5A). The Node B is controlled by an IPWireless INC (Integrated network Controller) or other vendors' RNC.

The Node B supports both 7.68Mcps (10MHz bandwidth) and 3.84Mcps (5MHz bandwidth) operation.

## Scope

This document covers the physical installation and mounting of the V5 Node B in a rack installation. It contains the specific mounting requirements for installing within a rack.

Specifications for the rack or cabinet indoor or outdoor are outside the scope of this guide and the responsibility of the customer.

Any installation must comply with the specifications within this document.

The manual does not detail custom or specialised installations or applications.

Additionally, antenna rigging/mounting, lightning protection, tower work, feeder installation / termination are all considered to be outside the scope of this guide.

If in any doubt about the suitability of this guide to successfully install at the proposed location, then please consult IPWireless technical support for assistance.

## 4. General Specifications

**Table 4-1 : Specifications**

<b>Unit</b>	<b>Specification</b>
Rack Specifications	19inch Mounting Racks with support shelves Front Securing
Measurements – incl front brackets	Control Shelf: 180 H / (4U) x 485 W x 310 D mm Radio Equipment Shelf: 222 H/(5U) x 485 W x 380 D mm
Measurements with front handles & cable	Control Shelf: 180 H / (4U) x 485 W x 510 D mm Radio Equipment Shelf: 222 H/(5U) x 485 W x 510 D mm
Node B Weight	Control Shelf: ≤13Kgs / 28 lbs Radio Equipment Shelf: ≤25kgs / 55 lbs
Power Consumption	Control Shelf: 350 Watts max (8Amp Fused). <b>Note:</b> Fuse Size: ( ¼ x 1 ¼ inch ) / (6.3 x 32 mm)
Heat Dissipation	Control Shelf 350 Watts - max Radio Equipment Shelf – 600 Watts - max
Input Power Nominal	-48 V DC
Input Range	-36V to -70V DC
Ambient Operational Environment	-20°C to +55°C 0 to 95% Relative Humidity- Non-condensing IP20 – IEC529 No water or Ice precipitation All other requirements to ETS300-019 Class 3.1E
Cooling	Forced Convection – Fan Assisted Cool Air Intake front & Exhaust rear
Operating Frequencies Note: Variant Radio Equipment shelf for each frequency	a) 2496 MHz – 2690 MHz b) 1900MHz – 1920MHz (20MHz or 5MHz bandwidths) c) 2010-2025MHz d) 3400MHz – 3615MHz e) 698-798MHz f) 2305-2360MHz
Connections - External	Antenna – DIN 7/16 Female (Radio Equipment shelf) GPS – N-type Female ( Control shelf) Power Circular Connectors – cables provided for each shelf Ethernet – RJ45 ( Control shelf) Optical MMF - LC-LC Duplex OM2 50/125um E1/T1 – RJ45 ( Control shelf-Control Card) – optional PMC module E3/T3 – BNC 75Ω ( Control shelf-Control Card) – optional PMC module Alarm – 15wayD ( Control shelf-Control Card) Earthing – M8 Bolt hole @ rear of each shelf

Figure 4-1 : Node B Rack Mount – Control Shelf Physical Dimensions

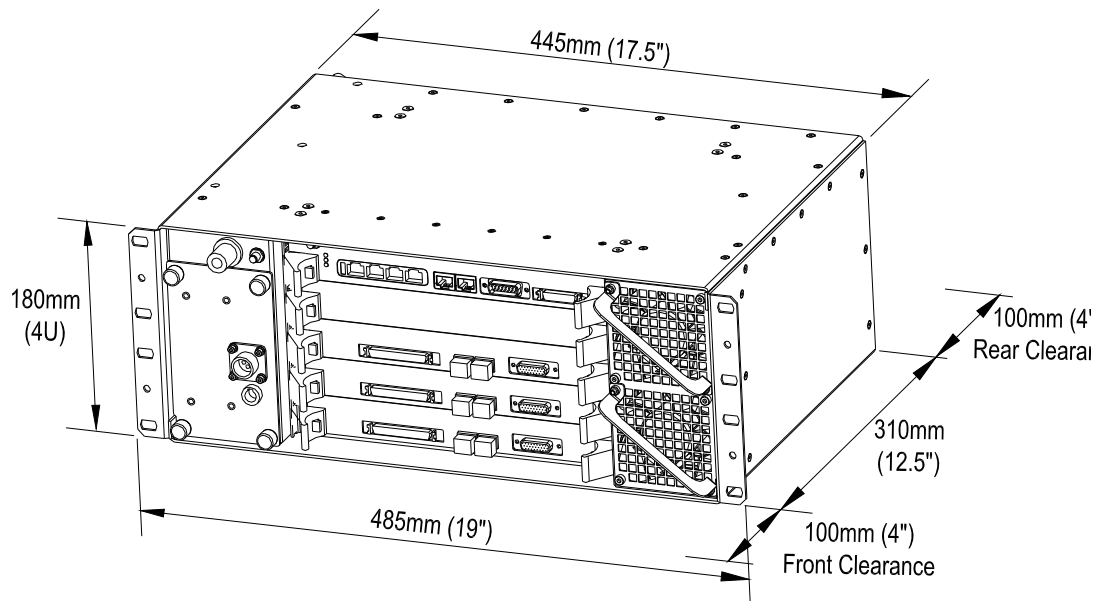
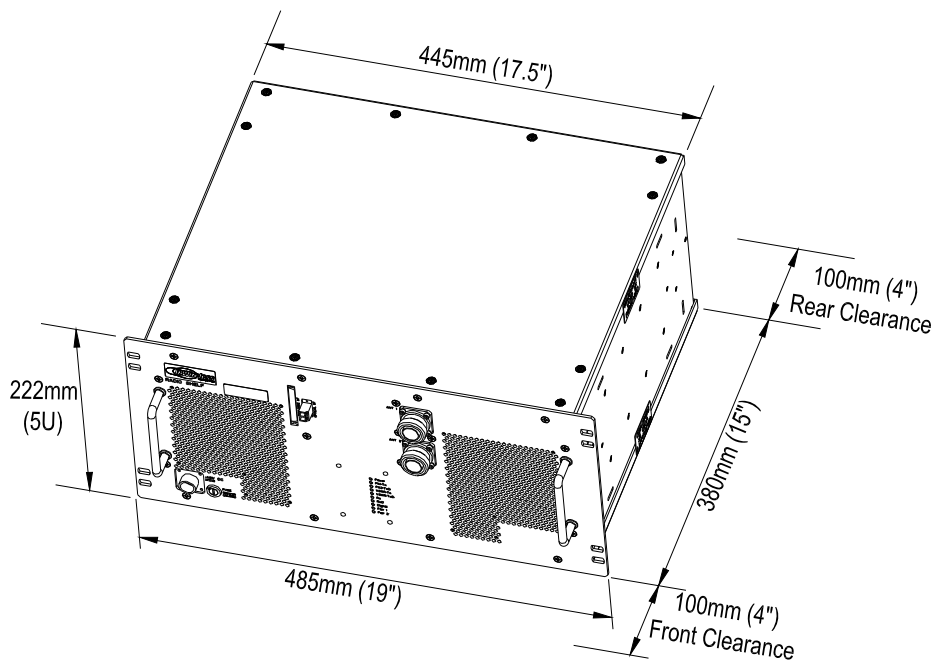

Figure 4-2 : Node B Rack Mount – Radio Equipment Physical Dimensions



**Table 4-2 : Node B Model Types**

	TxD 3.84Mcps +40dBm	TxD 7.68Mcps +37dBm	Non-TxD 3.84Mcps +40dBm	Non-TxD 7.68Mcps +37dBm
<b>Node B Frequency</b>				
698-798 MHz	√			
1900-1905 MHz	√		√	
1905-1910 MHz	√		√	
1910-1915 MHz	√		√	
1915-1920 MHz	√		√	
1900-1920 MHz	√	√	√	√
2010-2015 MHz	√	√	√	√
2305-2360MHz	√			
2496-2690 MHz	√	√	√	√
3400-3615 MHz	√	√	√	√

**Figure 4-3 : General Description – Front View**

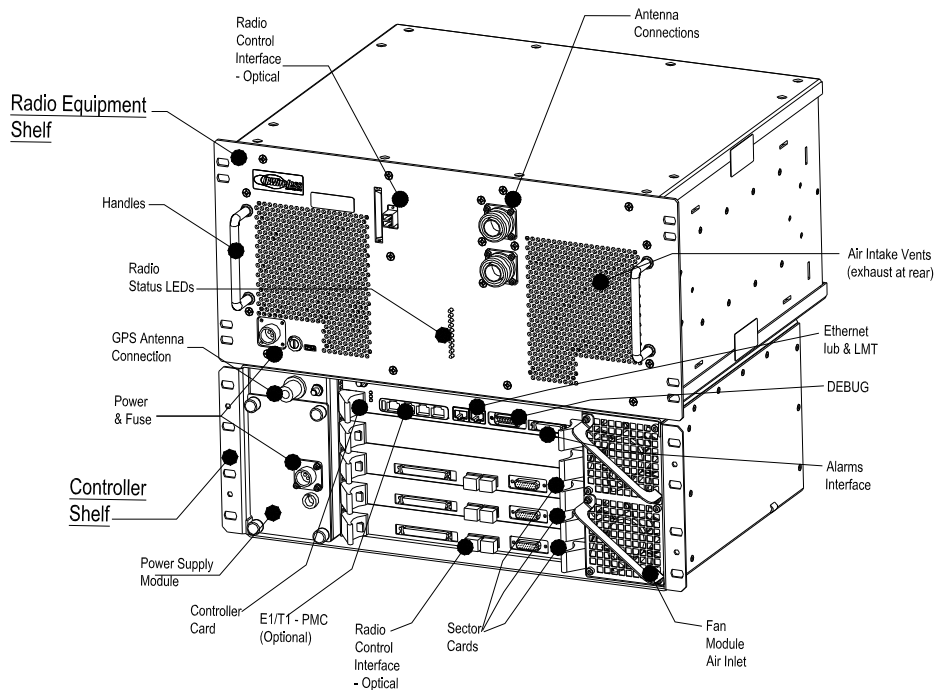

The Control shelf has the following interfaces on the front panel

- Mains DC supply + fuse
- Optical – MMF – Radio Control Interfaces
- IUB Interfaces
  - Ethernet 1000BaseT
  - or optional PMC E1/T1 or E3 / T3 (left-Rx & right-Tx)
- GPS Antenna Interface
- Alarm Interfaces – input & output
- LMT – 100BaseT
- Debug ports

On the rear the earth point and access to the rear fans.

**Figure 4-4 : Control Shelf Faceplate (dims mm)**

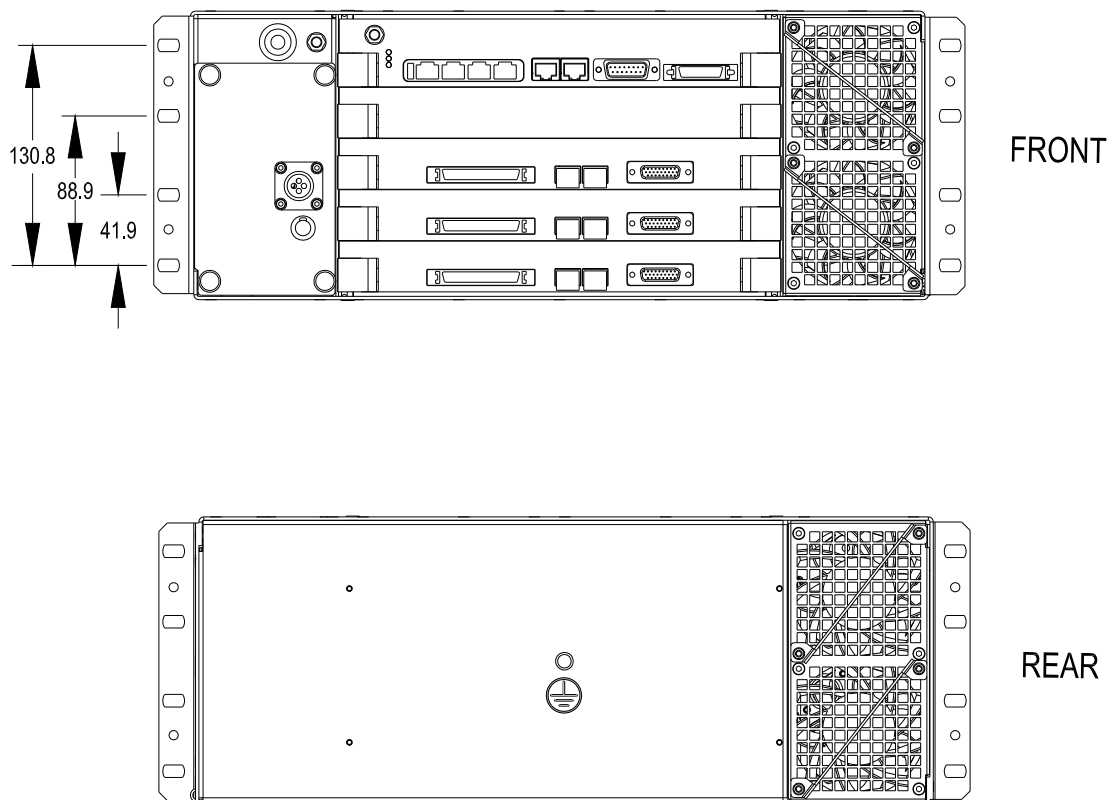

The Radio Equipment shelf has the following interfaces.

- Mains DC supply
- Optical MMF – Radio Control Interfaces to Control Shelf
- Antenna Ports
- Status – LEDs

On the rear the earth point and access to the fans.

**Figure 4-5 : Radio Equipment Shelf Faceplate**

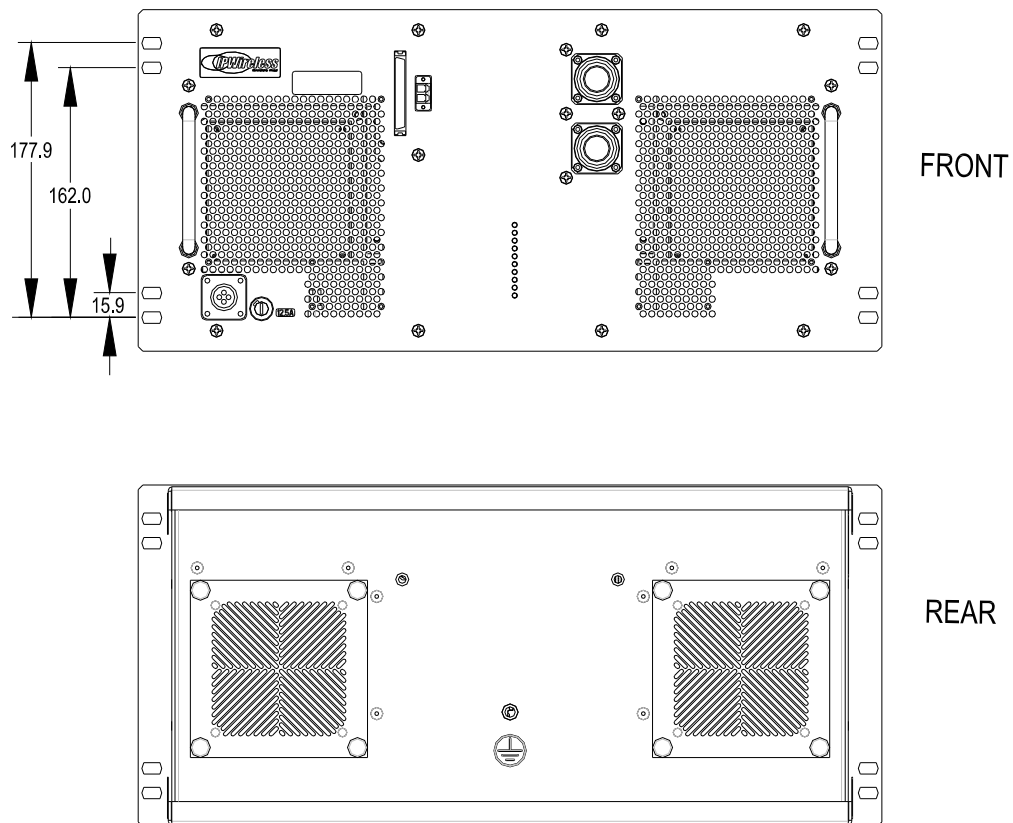

## **5. Installation**

This section describes the steps to be followed to physically install the Node B.

The Rack Mount installation has two basic physical configurations V5A or V5C Installation.

This section shall describe both configurations.

### **Step 1 Pre-Installation**

The following are the initial checks that should be carried out to ensure that preparation for the installation is complete.

For Installation Check Card please see Appendix A at the back of this manual.

1. Review site construction drawings to determine if site was constructed according to the drawings.
2. Review drawings and actual installation to determine location of Node B installation.
3. Check availability of electrical, grounding and antenna connections.
4. Complete site survey.
5. Check structural strength of mounting rack or frame including shelves/rails to support Node B total weight (V5A) or multiples if a multi-sector installation, V5C, (refer to Table 5-1).

## **Step 2 Parts Shipped & Tools Required**

This section reviews the parts, ancillary materials and tools required to install the Node B.

Use this checklist (Table 6-1 & 6-2, below) to check quantity and quality of parts as they are unpacked.

The Control Shelf crate contains the items listed in **Table 5-1** and is illustrated in **Figure 5-1**.

The Radio Equipment shelf crate contains the items listed **Table 6-2** and illustrated in **Figure 6-2**.



**Table 5-1 : Control Shelf - Packing List**

#	Description	Qty
	<b>Control Shelf Package - contents</b>	
1	<b>Node B Control Shelf Unit</b>	1
2	<b>GPS Antenna Kit incl Mounting</b> contains: 1 x GPS antenna 1 x GPS antenna mounting NOTE: The GPS kit can be supplied separately.	1
3	<b>Alarm Connector Kit</b> contains: 1 x 15wayD conn+backshell	1
4	<b>Power Connection Kit-Digital</b> contains 1 x power connection – digital	1
5	<b>Earth Fixing Kit</b> contains: 1 x M8 Nut 1 x M8 Spring Washer 2 x M8 Plain Washer	1
6	Fuse Kit contains 2 x Fuse – 7A	1

**Figure 5-1 : Control Shelf Package + Contents**

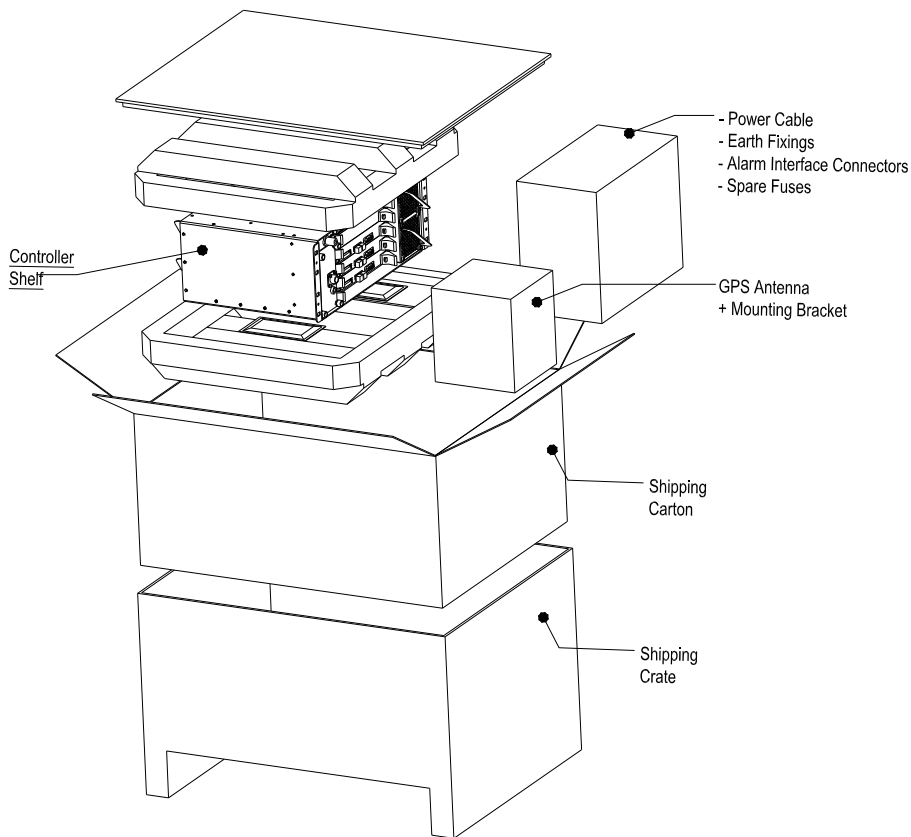

**Table 5-2 : Radio Equipment Shelf - Packing List**

#	Description	Qty
<b>Radio Shelf Package</b>		
1	Radio Shelf Unit	1
2	Power Connection Kit-Radio <u>contains</u> 1 x power connection – radio	1
3	Earth Fixing Kit <u>contains:</u> 1 x M8 Nut 1 x M8 Spring Washer 2 x M8 Plain Washer	1
4	Fuse Kit <u>contains</u> 2 x Fuse – 12.5A	1

**Figure 5-2 : Radio Equipment Shelf Package + Contents**

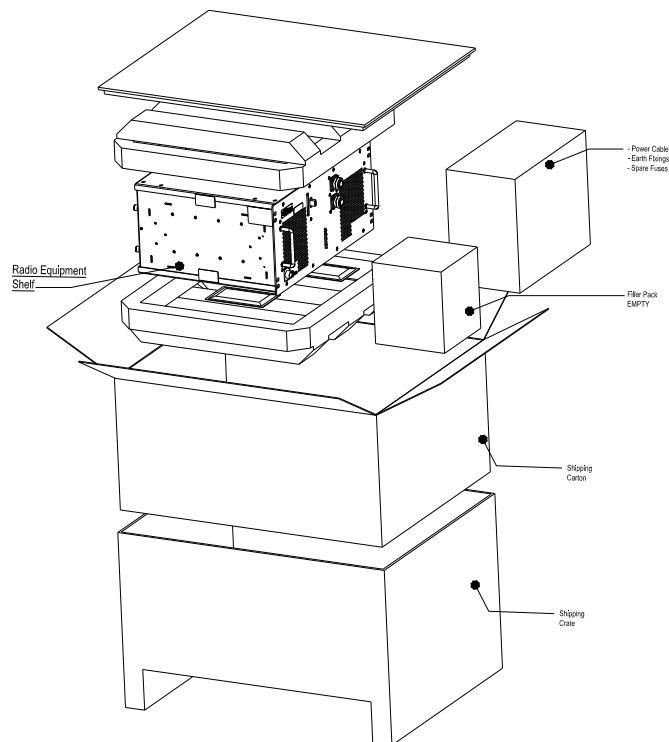

In addition to standard construction equipment, the following tools and materials should be available prior to installation:

**Table 5-3 : Tools Required**

<b>Tools</b>	<b>Description/Use</b>
Basic telecommunications tool kit	Includes screwdriver, socket wrenches, etc.
Voltmeter	Fluke meter
Cable Stripper & Crimper	RJ 45 crimper connector
Ethernet cable test set	Test for all Ethernet cables
Handheld GPS with signal indicator	Test for GPS signal at site location
Compass	Establish antenna directions

**Table 5-4 : Materials Required**

<b>Material</b>	<b>Description</b>
CAT5 - 4 pair, double screened cable, recommended Alcatel LANmark-5 F <sup>2</sup> TP or equivalent	IUB / LMT
RJ48C, 24AWG solid, 120 Ω, Straight-thru cable, each pair individually, screened cable	T1 / E1 Cable
RJ45 Connectors	IUB / LMT (optional T1 / E1 Connections)
CAT5 - 4 pair, double screened cable, recommended Alcatel LANmark-5 F <sup>2</sup> TP or equivalent	Alarm distribution cable
33mm <sup>2</sup> maximum Ground cable (2AWG)	Grounding termination
M8 ring terminal	Grounding termination
BNC Right Angle Connectors (75Ω)	Connectors for E3/T3 Connections (optional)
RG59 B/U-LSF and UV stabilised or equivalent	Cable for E3/T3 Connections
Rack mounting cage nuts + screws – note these are required to secure the shelves to the rack	typically M6 Thread screws, washers & rack cage nuts
Rack/Cabinet or Enclosure	Installation and/or site specific
Shelf Supports or rails	Specific to rack/cabinet or enclosure
DIN 7/16 antenna connections	Connectors specific to antenna cable chosen
Antenna Cable	Site specific selection

**Step 3 Site Preparations for Node B Installation**

The section specifies the facilities that need to be available at the site prior to installation. The table below is a site checklist that should be completed prior to installation.

It is assumed that the site has already been selected from RF network planning and site acquisition/permission has been granted.

**Table 5-5 : Site Preparation Checklist**

#	Facility	Complete Y/N
1	Mains power supply –48Vdc plus breaker.	
2	Availability of suitable Ethernet, E1/T1, E3/T3 Interfaces	
3	Connections and trunking/conduits for interfaces	
4	Suitable earth	
5	Rack or cabinet suitable to mount the Node B	
6	Clearance around the Node B for cable entry and cooling Note: if installed within enclosure/cabinet rack the environment for the Node B must meet the requirements as specified in Table 5-1.	

**Assumptions**

It is assumed that prior to Node B installation all civil, electrical distribution, structured cabling termination work has been completed.

Additionally, all antenna rigging, feeder runs and terminations, associated lightning protection plus grounding is complete, with certification for safety / compliance issued as required by local regulations.

It is also strongly recommended that all VSWR plots of the feeder / antenna installations should be available for inspection.

**Positioning the Node B with a rack or cabinet**

- The Control and Radio Equipment shelves may be mounted on a single shelf/shelf support as a pair (**Figure 5-3**) or can be mounted on separate shelves/supports.
- For the V5A and V5C illustrations the 1 or 3 RF shelves are shown on top with the Control shelf. The Control shelf may be positioned on top with the Radio Equipment shelves as shown in **Figure 5-4**.
- The maximum vertical distance between the shelves should not be greater than 1U (44mm or 1 3/4”).
- Selection of a suitable position for the Node B shall be done by surveying possible sites with regard to the availability of facilities i.e. power, relative position to the INC and consulting the site plans.
- Where the Node B is directly connected to the INC ie co-sited with the INC, the Node B should be sited not more than 100m from the INC using Shielded Category 5 Ethernet cable as specified.
- Care should be taken to position the Node B for easy front and rear access.
- The Node B will need to be connected near the feeder terminations and earthing points provided on site.
- Where the Node B is installed using a microwave link ensure that the microwave link can support the Ethernet requirements for the IUB interface i.e. 100Base-T or 10Base-T full / half duplex as the Node B and INC. If not the Node B and INC may need to be configured manually to support different configuration. Note: 100Base-T full duplex is recommended.

**Figure 5-3 : Node B Rack Mount – Single Support Shelf (all cables shown)**

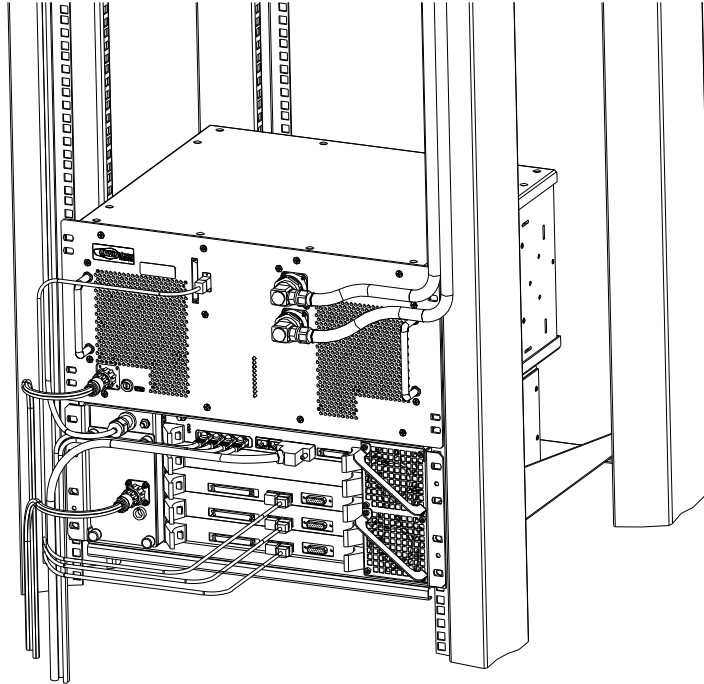
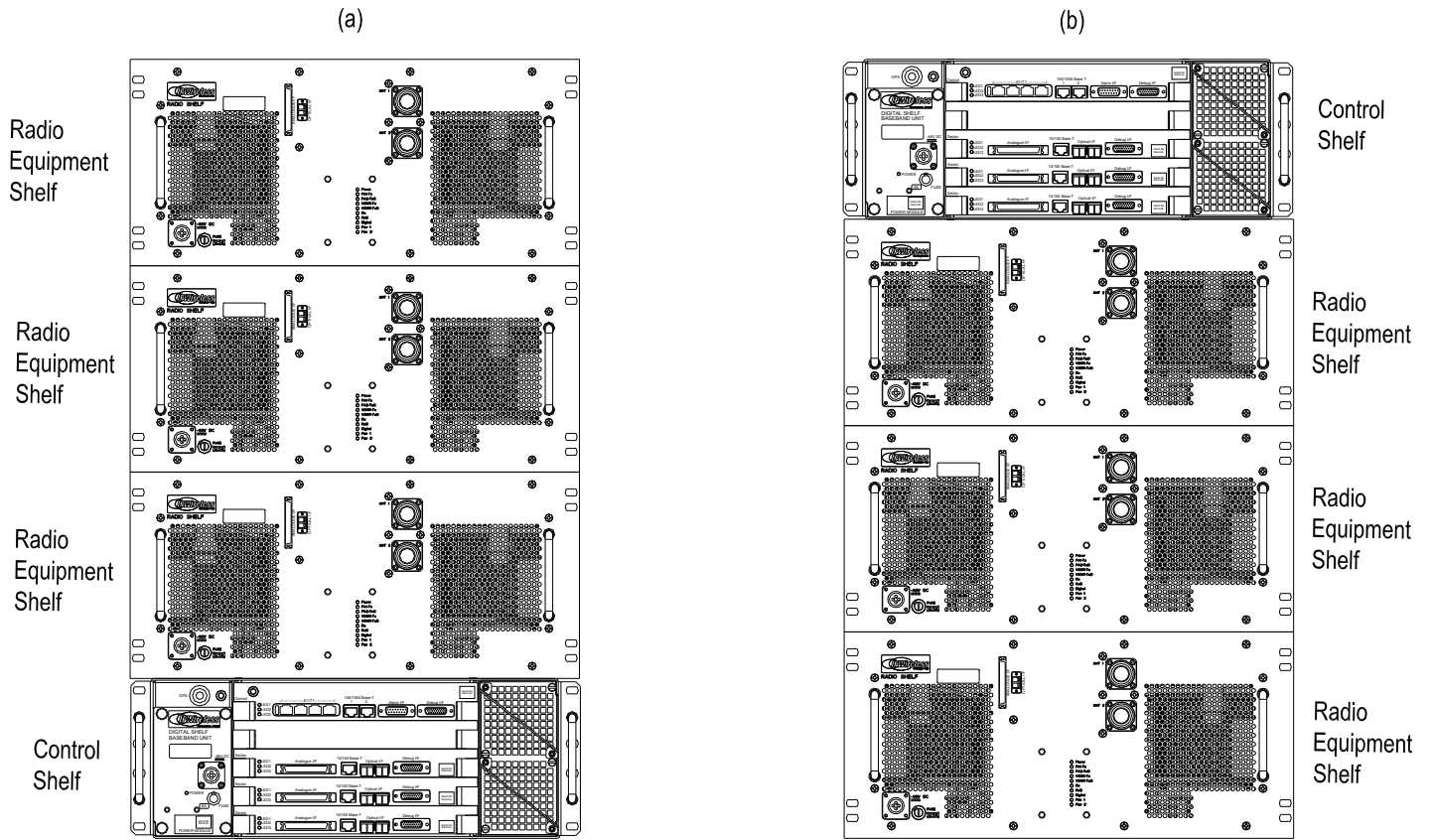

Figure 5-4 : V5C Node B Rack Mount – Alternative Stack-ups



**General Considerations**

The following consideration and checks are applicable to all mounting types :-

- ❑ The V5 Node B is designed for indoor or weather-proof enclosure use only - refer to Table 4-1.
- ❑ Review the GPS installation guidelines (step 12) to ensure that the location will allow proper operation of the Node B GPS remote antenna. i.e. a Southern Exposure is required for outside installations (Northern Hemisphere), a GPS repeater may be necessary in areas where the active GPS antenna cannot reach.
- ❑ There should be a minimum clearance of 100mm in front and behind the Node B rack mount (Figure 4-1 & Figure 5-2) for cable routing, air intake/exhaust and access to fans at the rear.
- ❑ Ensure that the rack or cabinet is sufficiently strong to support the Node B and other equipment that may be installed with it.
- ❑ The Node B requires un-restricted airflow at the front for air inlet and to the rear for air exhaust (see figures 5-1 & 5-2).
- ❑ Air filtration for the Node B environment should be specified at the cabinet/enclosure or building level see table 5-1 for specification.

## Step 4 Mounting Installations

This section explains how to mount the Node B Rack Mount shelves into racks.

### Mounting Rack

The figure below illustrates the 19inch mounting rack plus support shelves, some racks or cabinets can use support rails. This construction can be within an enclosure or cabinet.

The support shelves or rails are specific to the rack, enclosure or cabinet being installed, thus their specification shall be part of same selection.

Support shelves are required for easy of installation and support of the weight of the V5 Radio Equipment and Control shelves.

**Figure 5-5 : Mounting Rack + Support Shelves/Rails**

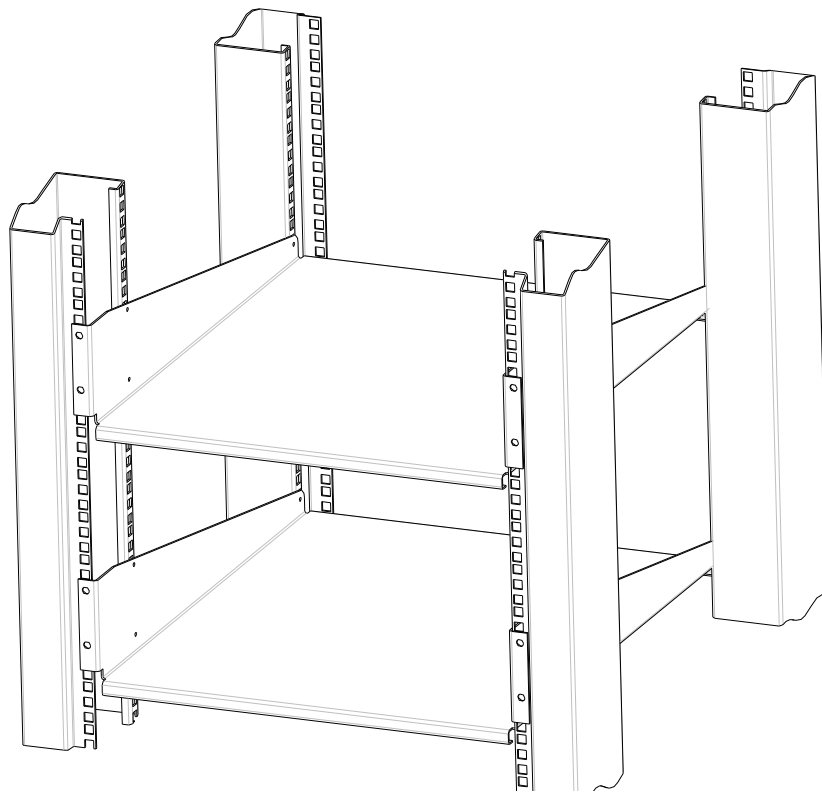





### Precautions

The following precautions and checks are applicable to all mounting types:-

- ❑ Connectors have been manufactured to fit their specific cables and function. Do not modify or force connectors.
- ❑ Check Site Plans for engineering approval.
- ❑ Ensure that good ground resistance is available at the installation site ( $\leq 10\Omega$ )
- ❑ Where installed in an outdoor enclosure attention should be paid to cooling and water+dust sealing prevention refer to Table 4-1.

### Rack Mounting – Installing Digital Shelf

Ensure the shelf or shelf supports are secure, then insert the digital shelf into the rack and secure from the front.

#### Notes:

- ❑ If there is no rear access it may be required to make the ground connection prior to inserting the shelf into the rack.
- ❑ Where additional securing is required at the rear this shall require custom brackets depending on the rack specifications/construction.

Figure 5-6: Installing Control Shelf

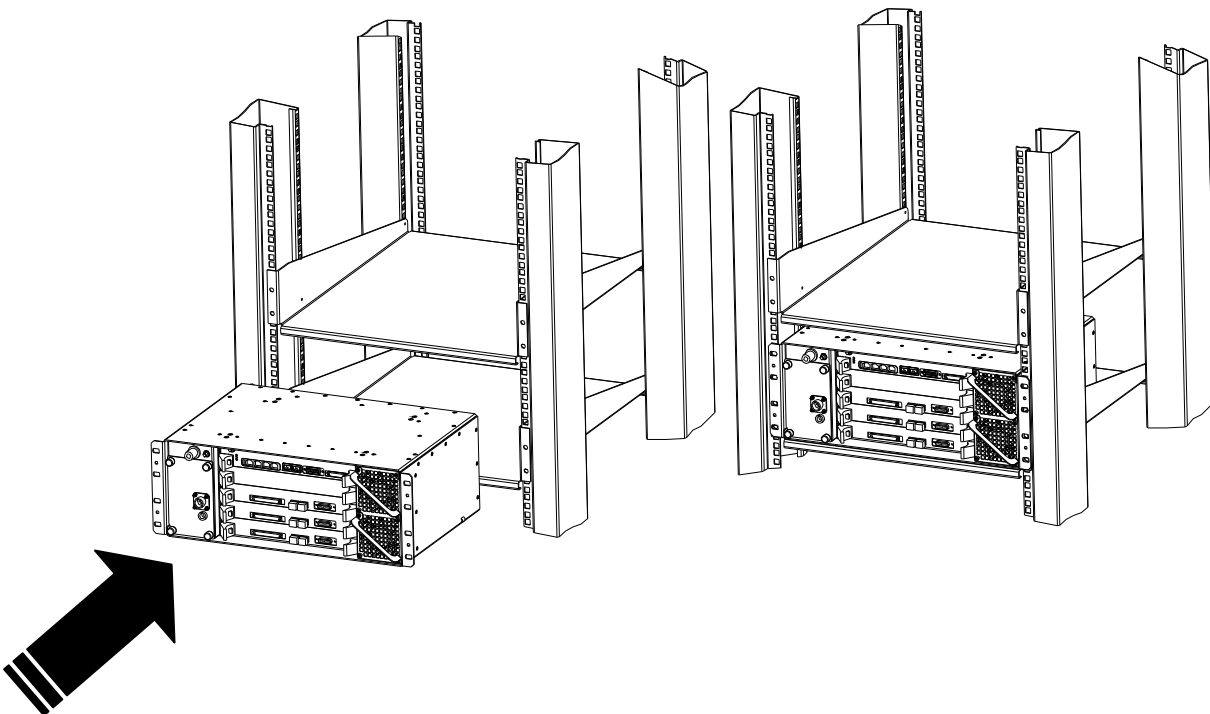

### Rack Mounting – Installing Radio Equipment Shelf

Ensure the shelf or shelf supports are secure, then insert the Radio Equipment shelf into the rack and secure from the front.

**Notes:**

- ❑ If there is no rear access it may be required to make the ground connection prior to inserting the shelf into the rack.
- ❑ Where additional securing is required at the rear this shall require custom brackets depending on the rack specifications/construction.

**Figure 5-7 : Installing Radio Equipment Shelf**

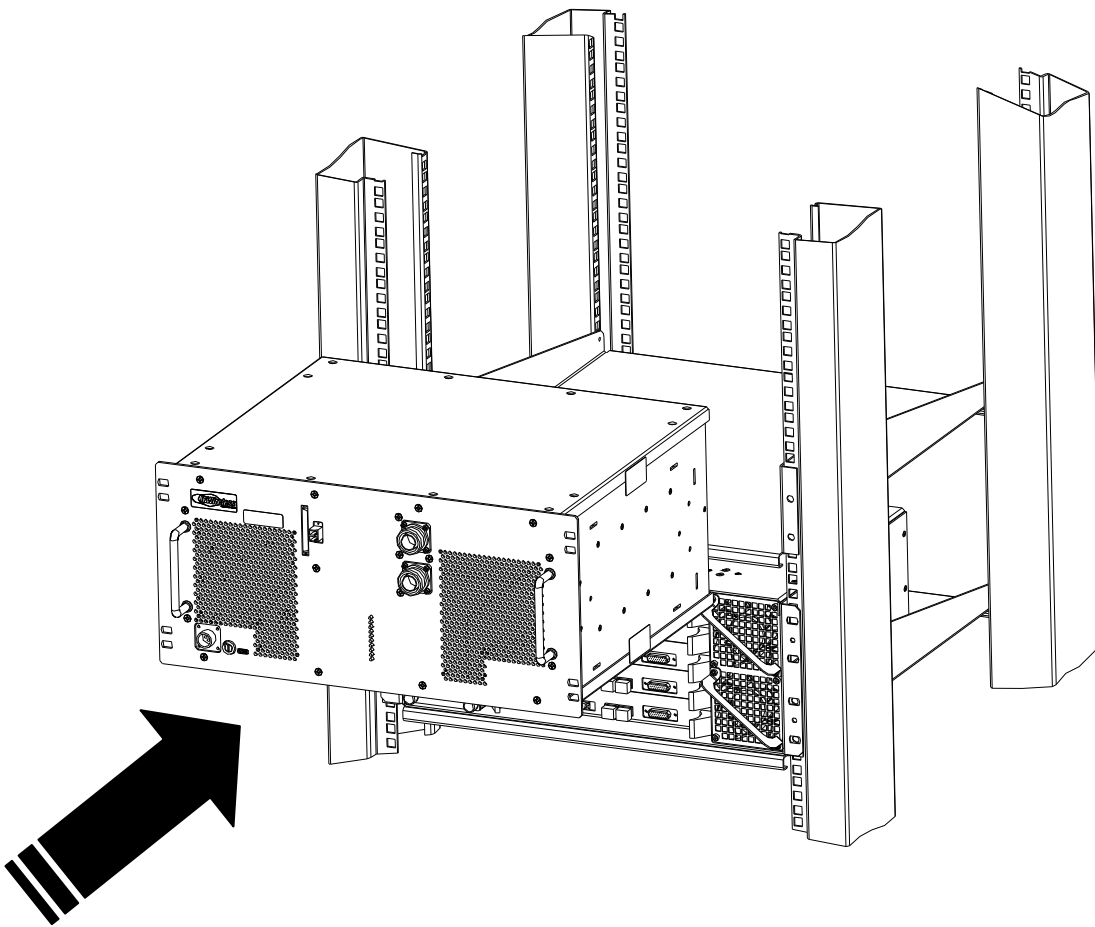



### Step 5 Ground Installation

The main Node B ground cable shall use a minimum #2 AWG (Diameter 6.6mm or CSA 33mm<sup>2</sup>) stranded wire or equivalent earth braid.

The ground cable is terminated on the rear of both shelves of the Node B Rack Mount using a terminal that shall fit the M8 bolt on the rear of each shelf.

The grounding wire is terminated onto the site grounding ring.

It should be noted that each site shall be designed for specific site, country or local installation requirements.



**CAUTION:** Ensure that the earth braid or cable is bonded to a common earth with equipment that is co-located with the Node B.

Figure 5-8 : Earth Connection on the rear of each shelf

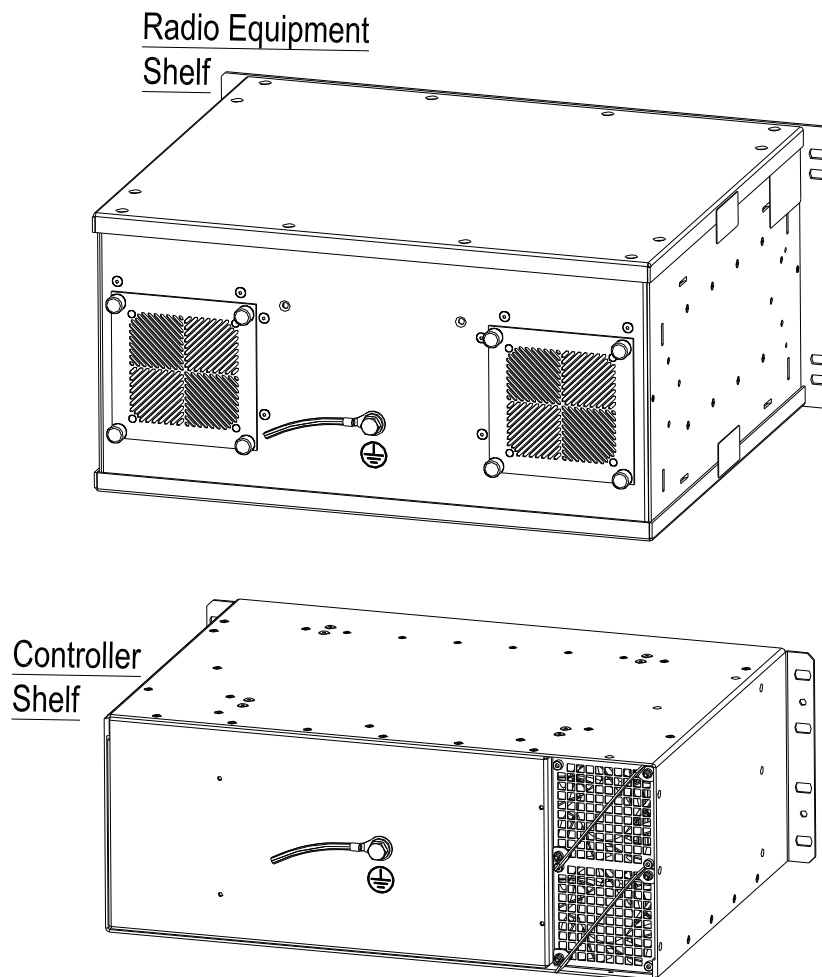

## Step 6 DC Power Connection-Control Shelf

The power supply input must be a nominal -48Vdc input, refer to Table 4-1.

The connection of the mains DC supply is via the cable provided as part of the digital shelf package.

The provided cable assembly has 3 metres of cable with a connector to provide connection to the digital shelf. The tail ends of the cable are stripped and must be terminated to a permanent connection junction/terminal block. The length of the cable may be shortened to facilitate installation.

### Notes:

- ❑ The Main DC supply should be configured with a separate DC return conductor and be bonded to the common protective earth according to ETSI EN 300 253 v2.1.1 (2002-04) Clause 6.1
- ❑ The Main DC supply to the equipment shall also be protected either by a fuse or circuit breaker at the connection point of the control shelf power cable.
- ❑ Only the cable provided with the Control shelf should be used.
- ❑ The connector is keyed to prevent wrong insertion.
- ❑ Cable connection voltages 0V and -48V are identified on the stripped ends of the power cable.

**Figure 5-9 : Power Connection to the Control shelf**

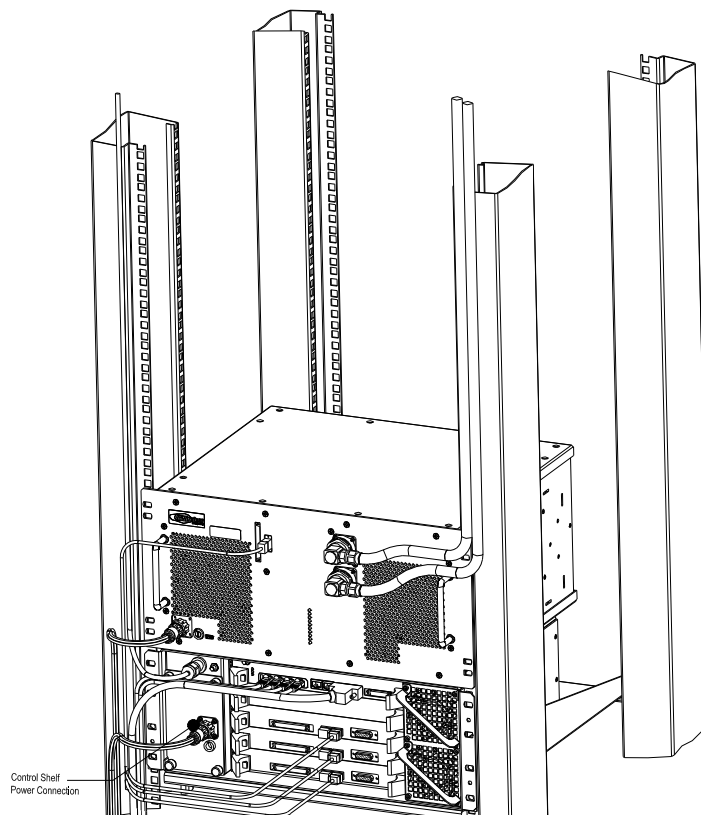

## Step 7 DC Power Connection-Radio Equipment Shelf

The power supply input must be a nominal -48Vdc input, refer to Table 4-1

The connection of the main DC supply is via the cable provided as part of the Radio Equipment shelf package.

The provided cable assembly has 3 metres of cable with a connector to provide connection to the Radio Equipment shelf. The tail ends of the cable are stripped and must be terminated to a permanent connection junction/terminal block. The length of the cable may be shortened to facilitate installation.

### Notes:

- ❑ The Main DC supply should be configured with a separate DC return conductor and be bonded to the common protective earth according to ETSI EN 300 253 v2.1.1 (2002-04) Clause 6.1
- ❑ The Main DC supply to the equipment shall also be protected either by a fuse or circuit breaker at the connection point of the radio equipment shelf power cable.
- ❑ Only the cable provided with the Radio Equipment shelf should be used.
- ❑ The connector is keyed to prevent wrong insertion.
- ❑ Cable connection voltages 0V and -48V are identified on the stripped ends of the power cable.

**Figure 5-10 : Power Connection to the Radio Equipment shelf**

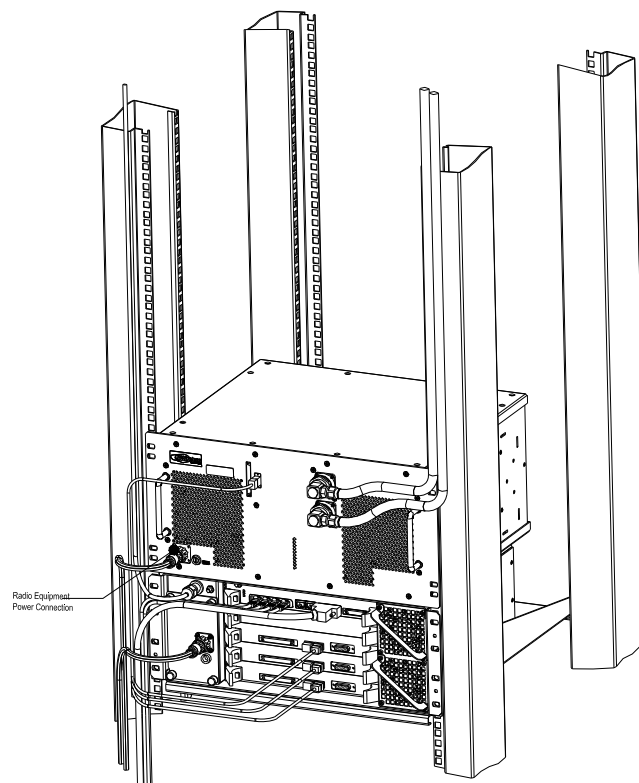

## Step 8 Inter-Shelf Connections

The optical MMF connections between the Control Shelf and Radio Equipment Shelves are required to be made in the field.

The SFP optical modules used in the V5 limit the maximum length for the MMF optical interface to

- ◇ 500metres (550yards) for 50/125um MMF
- ◇ 300metres (270yards) for 62.5/125um MMF

If longer lengths are required please contact IPWireless technical support for assistance.

The figures below illustrate the optical connections for these cables between the Control and Radio Equipment shelf V5A configuration for illustrations.

**Figure 5-11: Interface MMF Cable Connection**

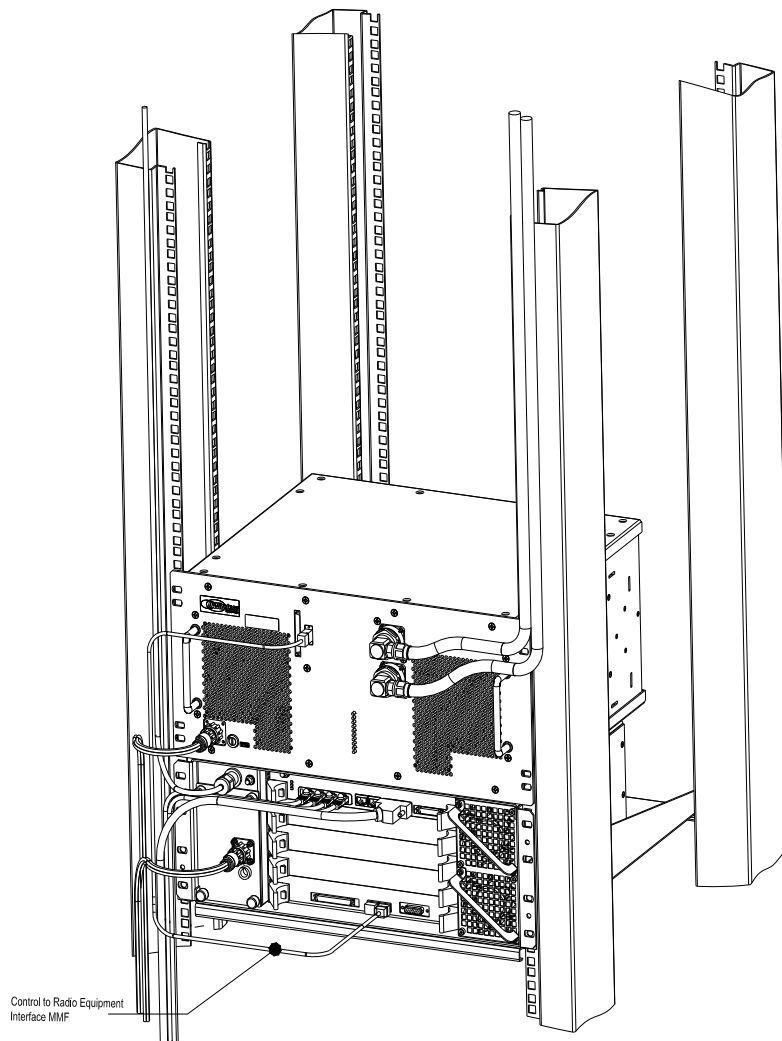

The figure below illustrates the front connections of power, antenna and inter-shelf cables between the digital and radio shelves for the V5C configurations.

**Figure 5-12: Interface Cable Connection – V5C**

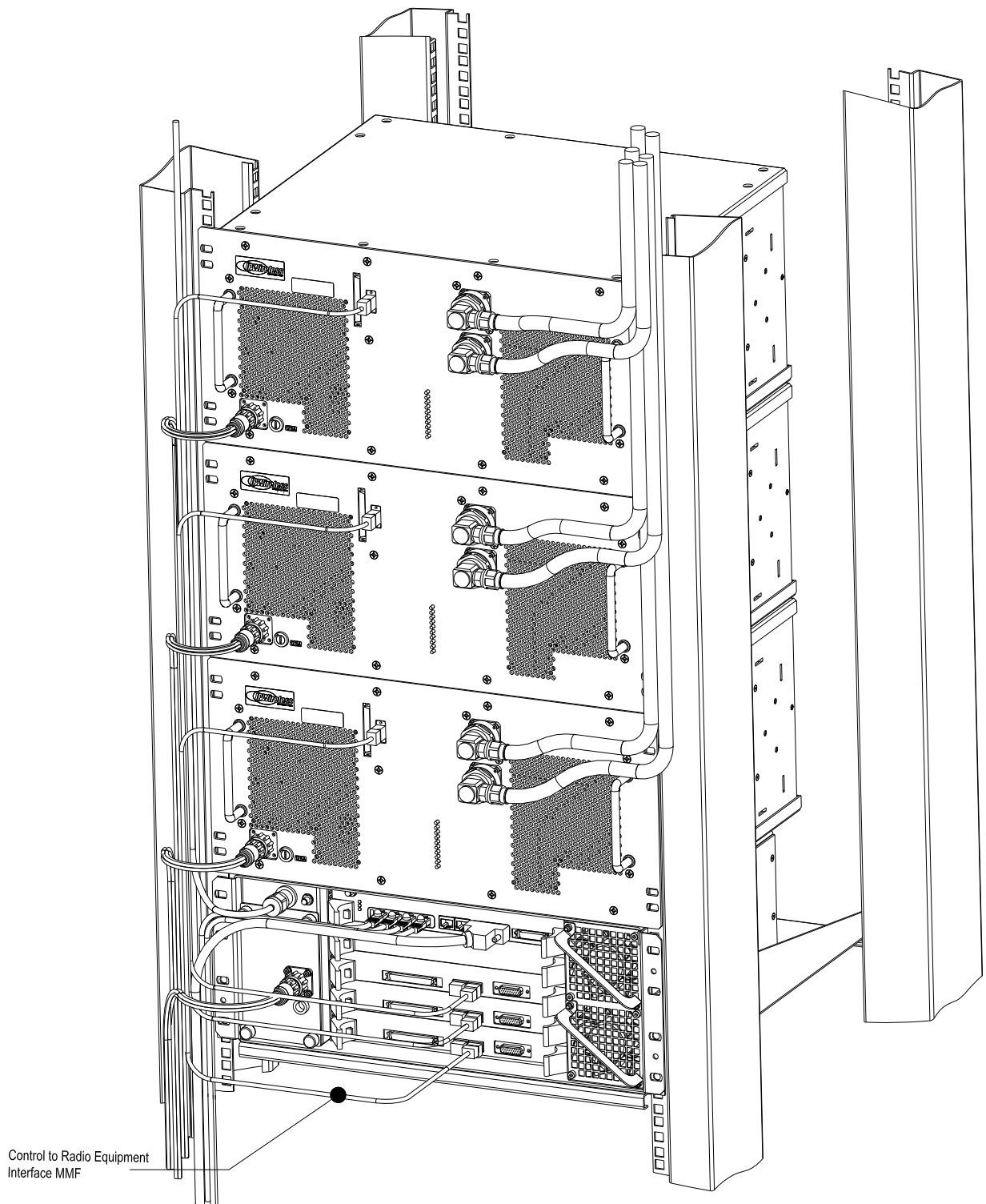



## Step 9 Backhaul Connections (Iub) to INC

The Control Shelf faceplate contains the backhaul connections. The installation can be selected from the following interfaces

- 1000BaseT
- E3/T3 – optional PMC card on Control Card
- E1/T1 – optional PMC card on Control Card

The connections are labeled and shown in the figure below.

**Note:** If the Node B is in not in the same site location as the serving INC, there must be no greater than a 5 millisecond delay on the backhaul connection. This can be provided by microwave or land based facilities with a reliability rate of 99.9995%.

**Figure 5-13 : Backhaul Connections**

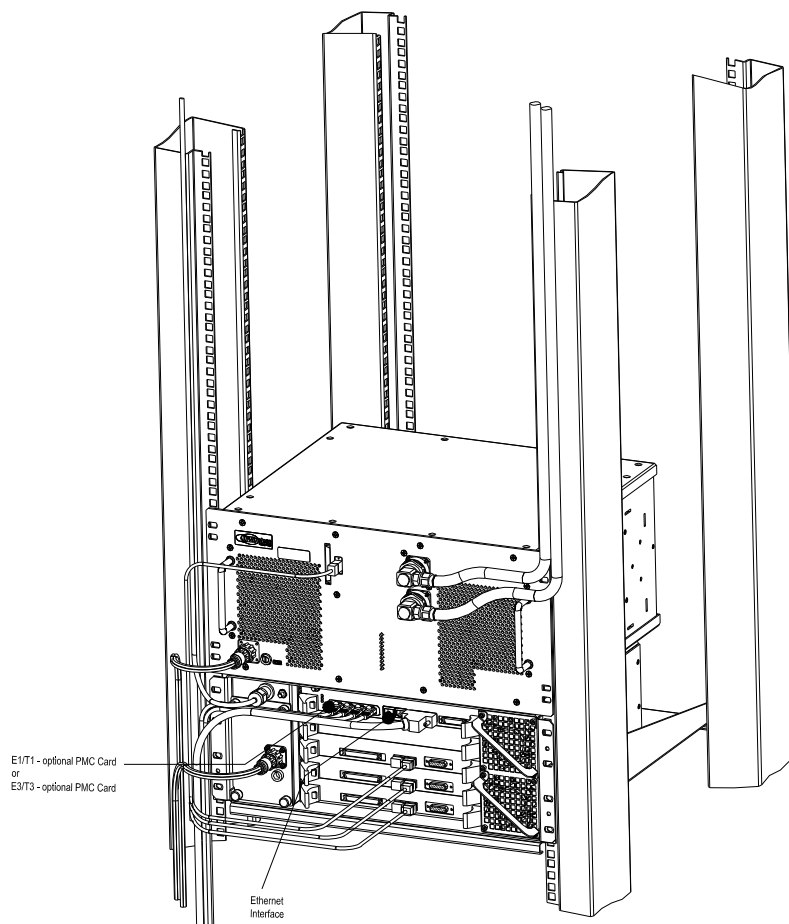



**1000BaseT Connection - (Eth)**

Terminate the Ethernet cables with RJ45 connectors and the cables may be secured to the brackets on the face of the Control Shelf (Figure 5-13). Test the continuity for the Ethernet cables with test equipment consisting of a main and a remote unit.

The termination for these interfaces is specified within the datasheets for the interfaces. The specification for both cables should be CAT5 - 4 pair, screened cable, recommended Alcatel LANmark-5 F2TP or equivalent.

**Notes:** Points to remember when installing Category 5 cables for the Node B 1000Base T Ethernet Backhaul.

1. Do not kink the cable as the pairs are twisted to support 100MHz operation and splitting the pairs could reduce the performance of the cable.
2. When installing the RJ45 plugs onto the cable ensure pairs are untwisted to the minimum and that the cable sheath is clamped within the connector. Again this is to ensure the performance of the cable is not reduced.

The pin-outs for the external Ethernet interfaces are given in the following table & figure.  
Source: <http://www.dcbnet.com/notes/9611t1.html>

**Table 5-6 : Ethernet Pin-outs using RJ45**

1	RX +	White w/Green
2	RX -	Green
3	TX +	White w/Orange
4		Blue
5		White w/Blue
6	TX -	Orange
7		White w/Brown
8		Brown

**Figure 5-14 : Ethernet Pin-outs using RJ45**

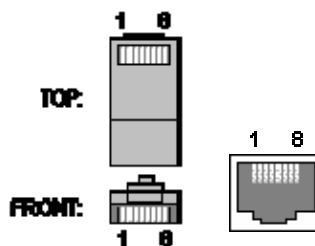

**E3/T3 Connections – (Tx + Rx)**

Terminate the E3/T3 cables with BNC connectors and the cables may be secured to the brackets on the face of the Digital Shelf (Figure 5-13). Test the continuity for the E3/T3 cables with test equipment consisting of a main and a remote unit.

The termination for these interfaces is specified within the datasheets for the interfaces. The specification for both cables should be 75Ω.

**E1/T1 Connections – (1 to 4)**

Terminate the E1/T1 cables with RJ45 connectors and the cables may be secured to the brackets on the face of the Digital Shelf (Figure 5-13).

Test the continuity for the E1/T1 cables with test equipment consisting of a main and a remote unit. The pin-outs for this interface are shown in the table below.

The termination for these interfaces is specified within the datasheets for the interfaces. The specification for both cables should be E1/T1 RJ48C, 24AWG solid, 120 Ω, Straight-thru cable, each pair individually, screened cable, recommended SC-7348 Stonewall Cable Inc, or equivalent.

**Table 5-7 : T1/E1 Pin-outs (RJ48C)**

T1 Pin-outs		Cable	E1 Pin-outs	
1	Rx (ring)	White w/Green	Rx (ring)	1
2	Rx (tip)	Green	Rx (tip)	2
3	Not used	White w/Orange	Not used	3
4	Tx (ring)	Blue	Tx (ring)	4
5	Tx (tip)	White w/Blue	Tx (tip)	5
6	Not used	Orange	Not used	6
7	Not used	White w/Brown	Not used	7
8	Not used	Brown	Not used	8

### Step 10 Antenna Cabling - Installation

Antennae and coaxial cable should be available at the site, and are part of the construction checklist and general assumptions.

Two antennae per Node B Radio Equipment Shelf are optimum, allowing receiver diversity and transmit diversity (note: if option fitted), therefore two coaxial cables per Node B are needed. Diversity can be via polarization, in which case two feeder runs to the same antenna are needed, feeding oppositely polarised sectors in the same physical enclosure.

Cables should be properly marked to indicate what antenna the coaxial cables are to be connected to the Node B serving the sector or area.

In the case where only one feeder / antenna is being used, this must be connected to the top connector when viewed from the front of the Node B. The unused port shall be terminated with a 50Ω load.

The following installation describes the position of the antenna ports and designations.

**Figure 5-15 : Antenna Connections & Routing**

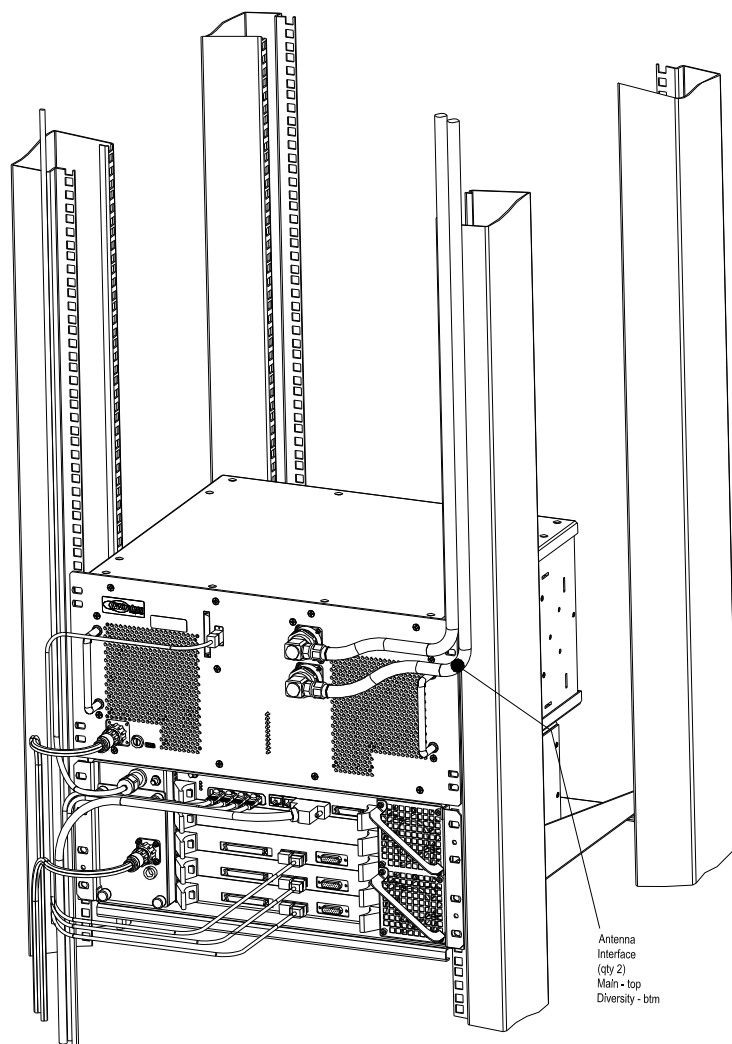

### Step 11 Alarm Connections

If local alarms are to be utilised one D-type connector is provided with the Node B Control shelf. The specifications for those interface requirements are below:-

**Figure 5-16 : Alarm Outputs & Inputs**

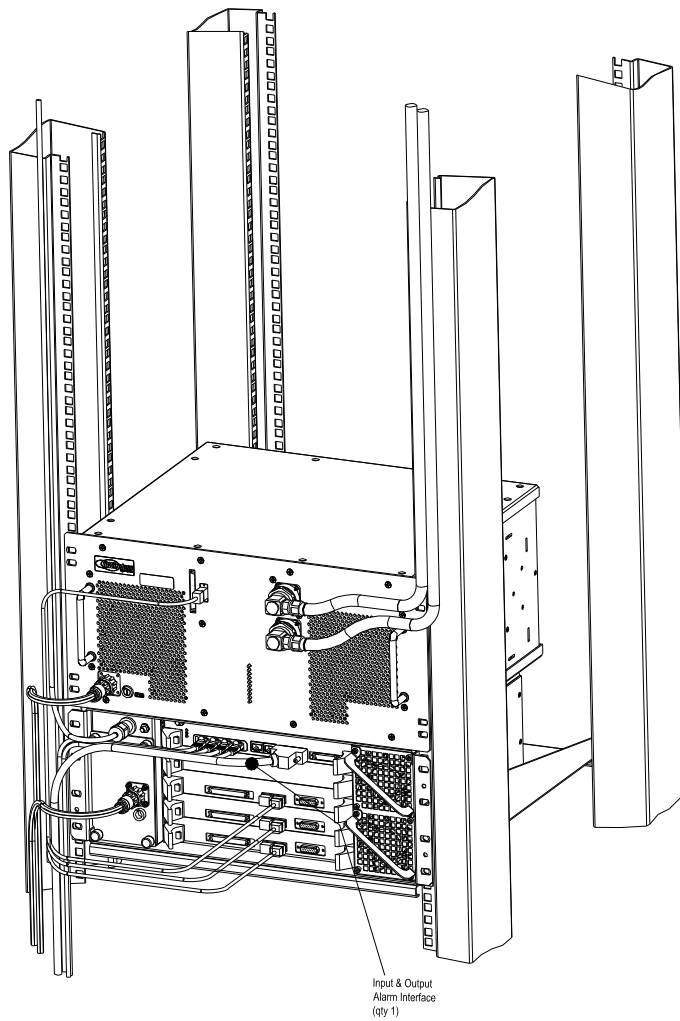

**Alarm Inputs**

There are five external alarm inputs are connected via the 15wayD male type located on the Control Card of the Control shelf.

The maximum input voltage is restricted to 12V and 2.5mA with a minimum working voltage of 6V. All five input circuits are the same.

The external alarm inputs are opto-isolated current loops. The voltage and currents shall be supplied by the external source.

The pin-out for the alarm inputs are shown in the table below.

**Table 5-8 : Alarm Inputs & Outputs**

Pin #	Signal
4	ALARM_IN_A0 +
11	ALARM_IN_B0 -
5	ALARM_IN_A1 +
12	ALARM_IN_B1 -
6	ALARM_IN_A2 +
13	ALARM_IN_B2 -
7	ALARM_IN_A3 +
14	ALARM_IN_B3 -
1	ALARM_OUT_A0 +
9	ALARM_OUT_B0 -
2	ALARM_OUT_A1 +
10	ALARM_OUT_B1 -
15	Earth
GND	D-Shell /Chassis GND

**Alarm Outputs**

The external alarm outputs are connected via the same 15wayD male located on the Control Card of the Control shelf.

The external alarm outputs shall be isolated normally-open relay contacts capable of switching 100mA DC.

The pin-out for the alarm inputs are shown in the table above.

**Step 12 GPS Installation & Operation**

The Node B has an external/remote GPS antenna and receiver. The connection for the antenna (N-Type) is located on the Control Shelf, **Figure 5-17**.

The GPS timing signal is used by the Node B for the TDD frame timing, so that all Node B's in a network are synchronized. The GPS signal is also used by the master oscillator for a frequency reference. The Node B can operate for two hours after a loss of GPS timing but a gradual drift of the frame timing will result in system interference and a loss of Node B selection / reselection capability.

A suitable Node B GPS antenna is shipped with every Node B. This antenna should be used with a total cable attenuation of minimum 8dB to maximum 25dB with male N-type connectors at each end. By example cable RG6 8dB  $\approx$  30m and 25dB  $\approx$  90m. For long runs, the cable losses will affect signal strength and could impede GPS signal performance.

For proper operation of the GPS receiver, the Node B GPS Antenna must have a clear southern view of the sky (northern hemisphere installations). A site survey should be done before Node B installation to verify that the Node B installation location is suitable for GPS reception.

A simple survey method is to take a handheld GPS receiver to the site and verify that GPS lock is obtained in the location of the Node B installation. The handheld GPS should be able to obtain a "locked" condition within 2 minutes of power-on, and should be able to see a minimum of 4 satellites at all times.

The GPS receiver, integral to the Node B Control shelf, is automatically enabled when the Node B is powered and there are no adjustments or settings to be made by the user.

**Note:** When the Node B installation is on or near a tower or building wall, the GPS survey should replicate the configuration.

**Figure 5-17 : GPS Antenna**

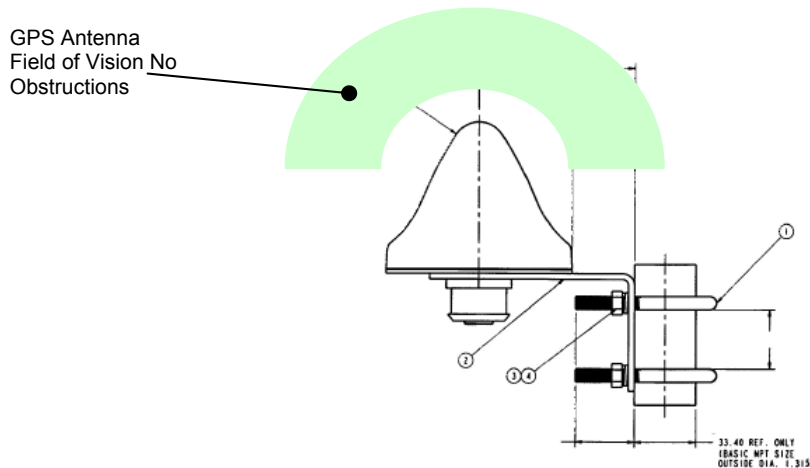
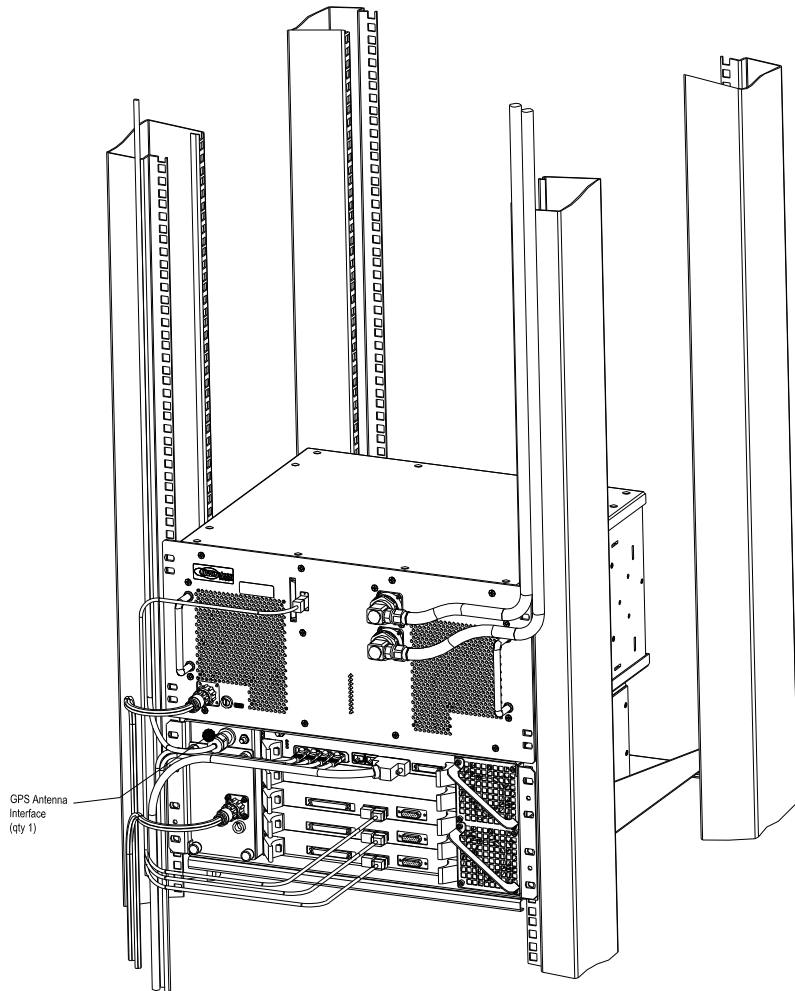

Figure 5-18 : GPS Antenna Connection



### Step 13 TTLNA Interfaces

Each V5 Radio Equipment shelf can support a TTLNA, the power and control are provided through the Antenna Coax connections.

Notes:

1. RF and Control cables to the TTLNA should not be disconnected while the Node B is transmitting.

The lightning protection on the TTLNA interfaces is 8kV/20mS to K21-ITU specification. If further protection is required then shall be added separately at the cabinet or building interface.

Figure 5-19 : TTLNA Connections

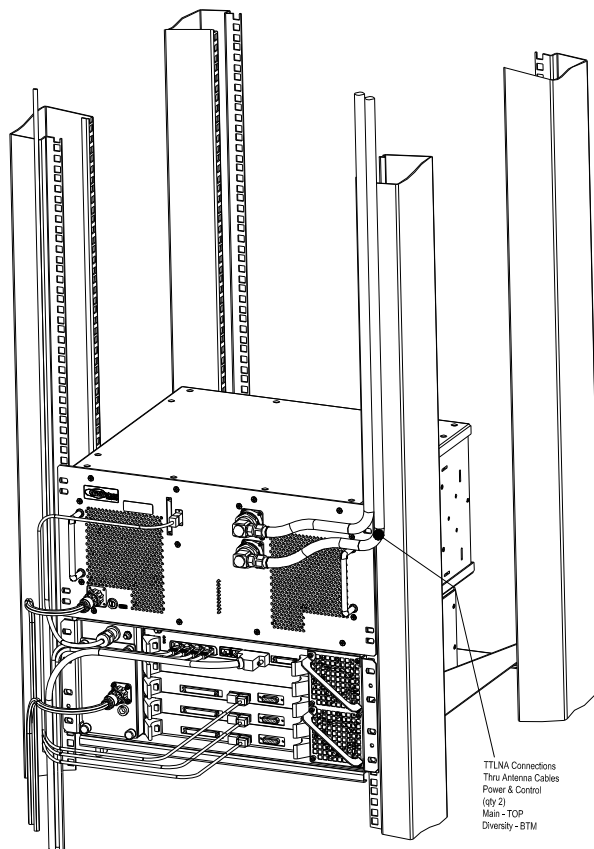



## 6. APPENDIX

### Appendix A - Installation Check Card

Step	Action	Complete	Comment	Page
1	Perform pre-installation site check			
2	Parts shipped/tools required			
3	Site Preparation			
4	Mounting rack/cabinet installation			
5	Grounding installation (all shelves)			
6	DC Power Connection-Digital Shelf			
7	DC Power Connection-Radio Shelf(s)			
8	Inter-shelf interface connections			
9	Backhaul Connections to INC			
10	Antennas Cabling - Installation			
11	Alarm Connections			
12	GPS Installation & Operation			
13	TTLNA Interfaces			

## Appendix B – Glossary

GLOSSARY	
ADC	Analog to Digital Converter
ARP	Address Resolution Protocol
BTS	Base Transceiver Station
DAC	Digital to Analog Converter
Downlink	From Network to the User Equipment
DSCH	Downlink Shared Channel
ESD	Electro Static Discharge
EM	Element Manager
EIA	Engineering Industry Association
Ethernet	10BaseT or 100baseT
ETSI	European Telecommunications Standardization Institute
FCC	Federal Communication Commission
FPGA	Field Programmable Gate Array
GPS	Global Positioning System
HTTP	Hyper-Text Transfer Protocol
INC	Integrated Network Controller
IP	Internet Protocol
ISP	Internet Service Provider
ITFS	Instructional Television Fixed Service
IuB	Interface Between the INC & Node B
LMT	Local Maintenance Terminal
LNA	Low Noise Amplifier
MCP	Multimedia Communications Port
MAC	Media Access Control
Mcps	Mega Chips per Second
MMDS	Multichannel Multipoint Distribution Service
MSPS	Mega Samples Per Second
MTU	Maximum Transmission Unit
Node B	A UMTS Radio Base Station
PDU	Protocol Data Unit
PLL	Phase Locked Loop
QPSK	Quadrature Phase Shift Keying
RAM	Random Access Memory
RLC	Radio Link Control
SRAM	Static RAM
T1/E1	1536kbps/ 2048Kbps pipe
T3/E3	45Mbps or 34Mbps
UE	User Equipment
UMTS	Universal Mobile Telecommunications System
Uplink	From User Equipment to the Network

<b>GLOSSARY</b>	
USB	Universal Serial Bus
USCH	Uplink Shared Channel
UPS	Uninterruptible Power Supply Unit
UTRAN	UMTS Terrestrial Radio Access Network
VSWR	Voltage Standing wave ratio
VCXO	Voltage Controlled Crystal Oscillator

**END OF DOCUMENT**