

Developer Board 4 Hub

UserGuide

Powered by:

Geniatech

Contents

1	Introduction	4
2	What's in the Box	7
3	Getting started.....	8
3.1	Prerequisites.....	8
3.2	Starting the board for the first time.....	8
4	DB4 Overview	9
4.1	System Block diagram.....	9
4.2	Processor	9
4.3	Memory.....	9
4.4	MicroSDHC.....	9
4.5	Ethernet.....	10
4.6	WiFi/BT/RF	10
4.7	Display Interface	10
4.7.1	HDMI	10
4.7.2	MIPI-DSI	11
4.8	Camera Interfaces	11
4.9	USB Ports	11
4.9.1	USB-Host ports	11
4.9.2	USB-Device port.....	12
4.10	Audio.....	12
4.10.1	BT Audio.....	12
4.10.2	HDMI Audio.....	12
4.11	DC-power and Battery Power.....	12
4.12	Measurements	13
4.13	Buttons	13
4.14	External Fan connection	13
4.15	UART.....	13
4.16	JTAG	13
4.17	System and user LEDs.....	13
4.18	Expansion Connector	13
4.19	Additional Functionality	14
4.19.1	On Board Analog Microphone	14
4.19.2	Analog Connector.....	14
5	Low speed Expansion connector	15
5.1	UART {0/1}.....	17
5.2	I2C {0/1}.....	17
5.3	GPIO {A-L}.....	17

5.4	SPI 0	17
5.5	PCM/I2S.....	17
5.6	Power and Reset	18
5.7	Power Supplies	18
6	High speed expansion connector.....	19
6.1	MIPI DSI 0	21
6.2	MIPI CSI {0/1}	21
6.3	I2C {2/3}.....	21
6.4	HSIC.....	22
6.5	Reserved	22
6.6	SD/SPI.....	22
6.7	Clocks	22
6.8	USB	22
7	Analog Expansion Connector	23
7.1	Speaker.....	23
7.2	Mic.....	23
7.3	Headset	23
7.4	FM Antenna	23
8	Power management	25
8.1	DC Power Input	25
8.2	Power Source Selection	25
8.3	Power Consumption.....	26
8.4	Power Sequencing.....	26
8.5	Voltage Rails.....	26
8.6	Power Measurements	26
	8.6.1 Power-In measurement	26
	8.6.2 PMIC Power-In measurement	26
9	Buttons and status LED's	27
9.1	Buttons	27
	9.1.1 Volume up	27
	9.1.2 Volume down	27
	9.1.3 Power Button.....	27
	9.1.4 Reset Button	27
9.2	LED's	27
	9.2.1 User LED 1-4.....	27
	9.2.2 Bluetooth status.....	27
	9.2.3 WiFi status	27
	9.2.4 Ethernet status	27
10	Boot configuration	28

1 Introduction

The Developer Board 4 Hub(hereinafter referred to as DB4) is a 96Boards compliant community board based on Qualcomm® Snapdragon 400 series of SoC's.

The following table lists its key features:

Processor	Qualcomm Snapdragon 410 Quad-core ARM® Cortex® A53 at up to 1.2 GHz per core 64-Bit capable Qualcomm Adreno 306 400MHz GPU for PC-class graphics with support for advanced APIs, including OpenGL ES 3.0, OpenCL, DirectX, and content security
Memory/ Storage	1GB or 2GB LPDDR3 533MHz 8GB or 16GB eMMC 4.51 SD 3.0 (UHS-I)
Video	1080p@30fps HD video playback and capture with H.264 (AVC), and 720p playback with H.265 (HEVC)
Camera Support	Integrated ISP with support for image sensors up to 13MP
Audio	PCM/AAC+/MP3/WMA, ECNS, Audio+ post-processing (optional)
Connectivity	WLAN 802.11 b/g/n 2.4GHz 10/100M Ethernet Bluetooth 4.1 One USB 2.0 micro B (device mode only) Two USB 2.0 (host mode only) On-board BT and WLAN antenna
I/O Interfaces	One 40-pin Low Speed (LS) expansion connector • UART, SPI, I2S, I2C x2, GPIO x12, DC power One 60-pin High Speed (HS) expansion connector • 4L-MIPI DSI, USB, I2C x2, 2L+4L-MIPI CSI Footprint for one optional 16-pin analog expansion connector for stereo headset/ line-out, speaker and analog line-in The board can be made compatible with Arduino using an add-on mezzanine board

External Storage	Micro SD card slot
User Interface	<p>Power/Reset</p> <p>Volume Up/down</p> <p>7 LED indicators</p> <ul style="list-style-type: none"> • 4 - user controllable • 3 - for BT、WLAN and Ethernet activity
OS-support	<p>Android 5.1</p> <p>Linux based on Debian</p> <p>Windows 10 IoT core</p>
Power, Mechanical and Environmental	<p>Power: +6.5V to +18V</p> <p>Dimensions: 60mm by 85mm meeting 96Boards™ Consumer Edition standard dimensions specifications.</p> <p>Operating Temp: -25°C to +70°C</p> <p>RoHS and Reach compliant</p>

1.1 Board overview

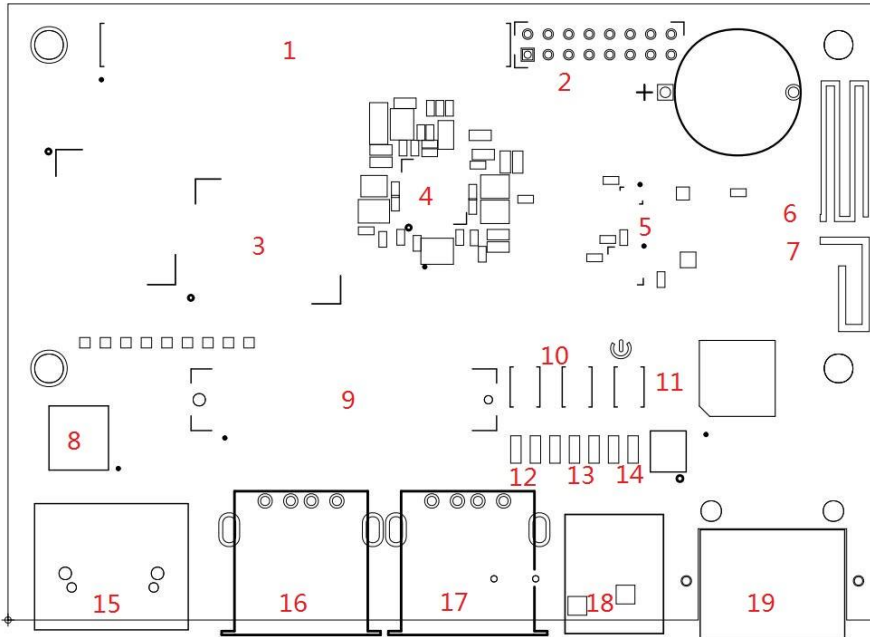

1.	(J8) Low Speed Expansion Connector
2.	(J7) Analog Expansion Connector
3.	APQ8016 Snapdragon Processor
4.	(U9) Power Management PMIC
5.	WLAN/Bluetooth
6.	Bluetooth/WLAN Antenna
7.	(S6) Boot Switches
8.	(J9) High Speed Connector
9.	(S3-4) Vol+ / Vol- Buttons
10.	(S2) Power Button
11.	Bluetooth/WLAN LED's
12.	User LED's 1-4
13.	Ethernet LED
14.	(J6) HDMI Type A Port
15.	(J3) USB Host2 Connector
16.	(J2) USB Host1 Connector
17.	(J1) Power Jack
18.	(J16) Ethernet Connector
19.	(J5) uSD Card Socket
20.	(J4) Micro USB Type B Connector
21.	Apple Authentication IC

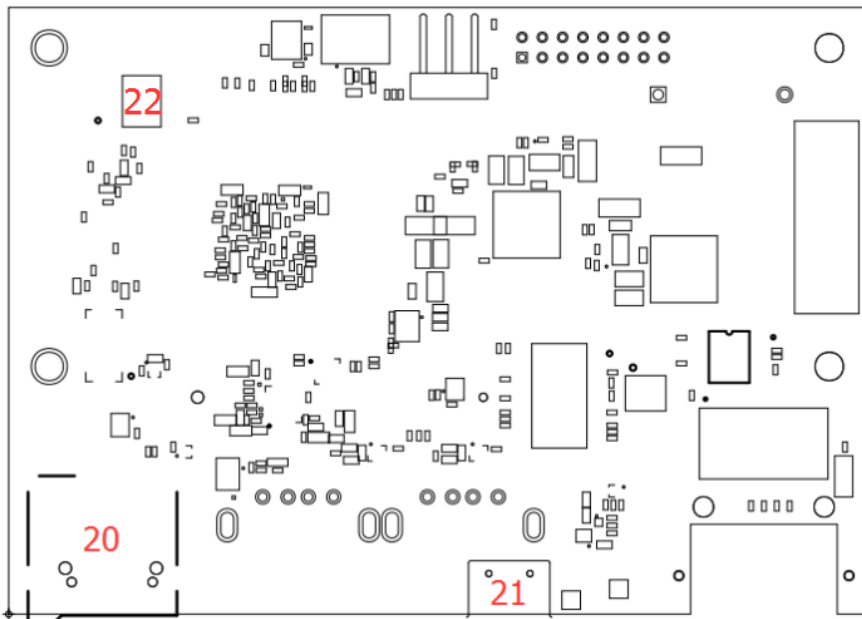

2 What's in the Box

The box contains one DB4.

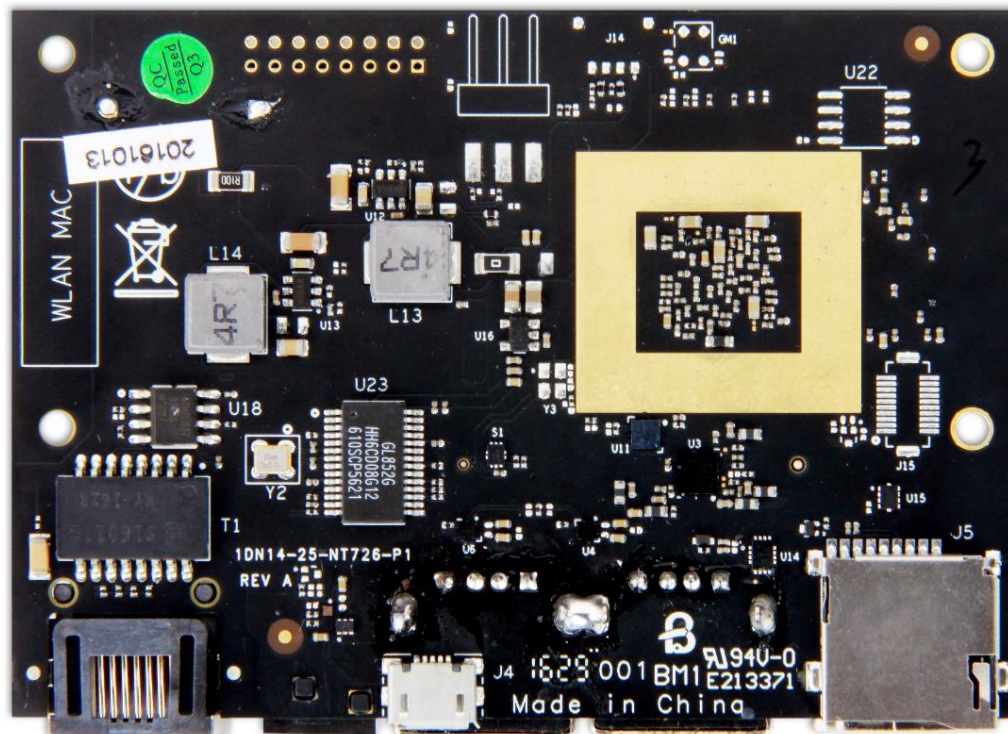
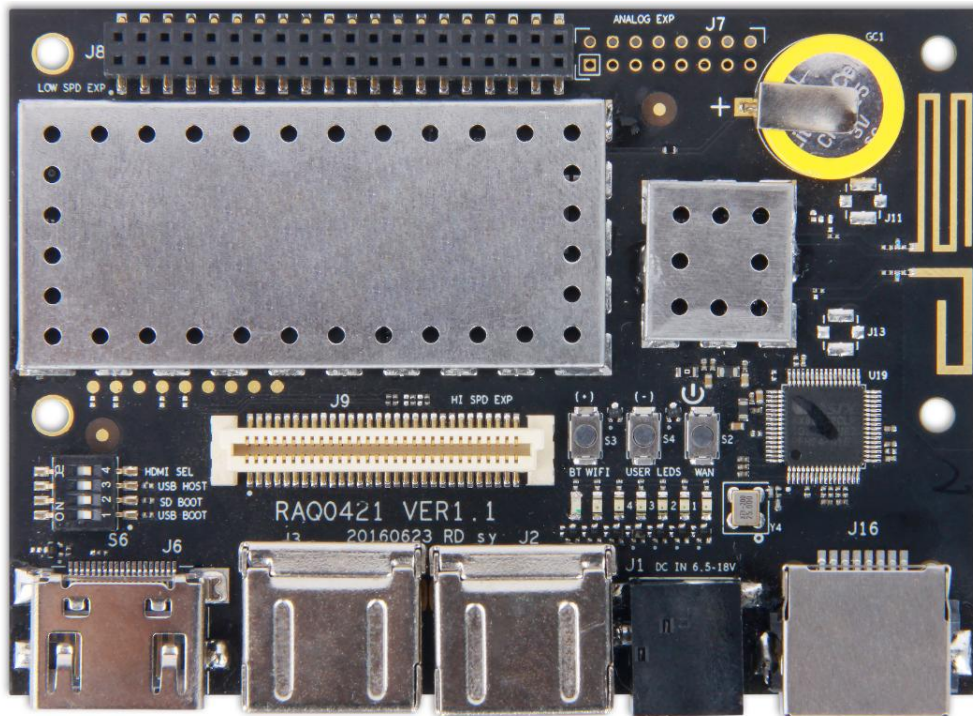

3 Getting started

3.1 Prerequisites

Before you power up your DB4 for the first time you will need the following:

- DB4 board.
- A 96Boards compliant power supply (sold separately by Geniatech).
- A HDMI or DVI LCD Monitor that supports a resolution of 1080P/30Hz.
- HDMI-HDMI cable or HDMI-DVI cable to connect the board to the Monitor.
- A computer keyboard with USB interface
- A computer mouse with USB interface.

3.2 Starting the board for the first time

To start the board, follow these simple steps:

- step 1. Connect the HDMI cable to the DB4 HDMI connector (marked J6) and to the LCD Monitor.
- step 2. Connect the keyboard to the boards USB connector marked J3 and the mouse to the USB connector marked J2. (It doesn't matter which order you connect them in. You can also connect via an external USB Hub.)
- step 3. *Ensure that the boot switches S6 are set to '0000', all in Off position.***
- step 4. Connect the power supply to power connector J1.

Once you plug the power supply into a power outlet the board will start the booting process, and you should see Android boot up.

Please note that the first boot takes several minutes due to Androids initialization. Subsequent boot times should be faster.

4 DB4 Overview

4.1 System Block diagram

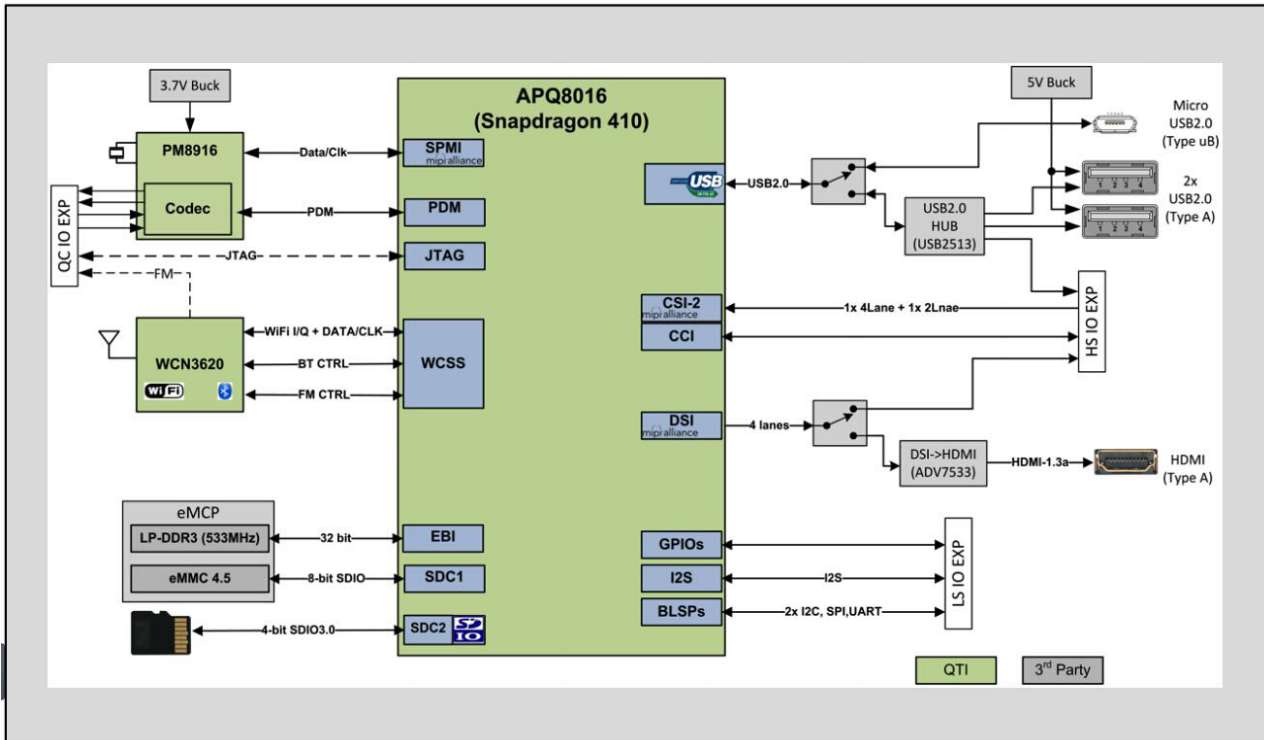

4.2 Processor

The Snapdragon 410 APQ8016 is a quad 64-bit ARM Cortex-A53 MPcore Harvard Superscalar core, supports both LP-DDR2 / LP-DDR3 SDRAM interface, Hexagon QDSP6, 13.5 MP camera input support, Adreno 306 GPU, 1080p video encode/decode, Bluetooth 4.1, OpenGL ES 3.0, DirectX, OpenCL, Renderscript Compute, FlexRender support.

4.3 Memory

The DB4 uses a single embedded Multi Chip Package (eMCP) dual function LPDDR3/eMMC memory solution. The installed chip provides 16Gbyte of solid state storage and 2Gbyte of LPDDR3.

- The LPDDR3 is a 32bit width bus implementation interfacing directly to the APQ8016 build-in LPDDR controller. The maximum DDR clock is 533Mhz
- The eMMC is an 8bit implementation interfacing with APQ8016 SDC1 interface supporting eMMC 4.5 specifications.

4.4 MicroSDHC

The 96Boards specification calls for a microSDHC socket to be present on the board.

The DB4 μ SD slot (J5) signals are routed directly to the APQ8016 SDC2 interface. The slot is a push-push type with a dedicated support for card detect signal (many μ SD slots do not have a dedicated CD pins, they use DATA3 state as the card detected signal). The DB4 uses APQ GPIO_38 as the SD_CARD_DET_N.

4.5 Ethernet

The DB4 deployed ASIX' USB2.0 to 10/100M Fast Ethernet Controller AX88772C solution which enables a low cost, small form factor, and simple plug-and-play Fast Ethernet network connection capability.

4.6 WiFi/BT/RF

The 96Boards specifications calls for a WiFi (minimally 802.11g/n) and Bluetooth 4.1 (Bluetooth Low Energy)

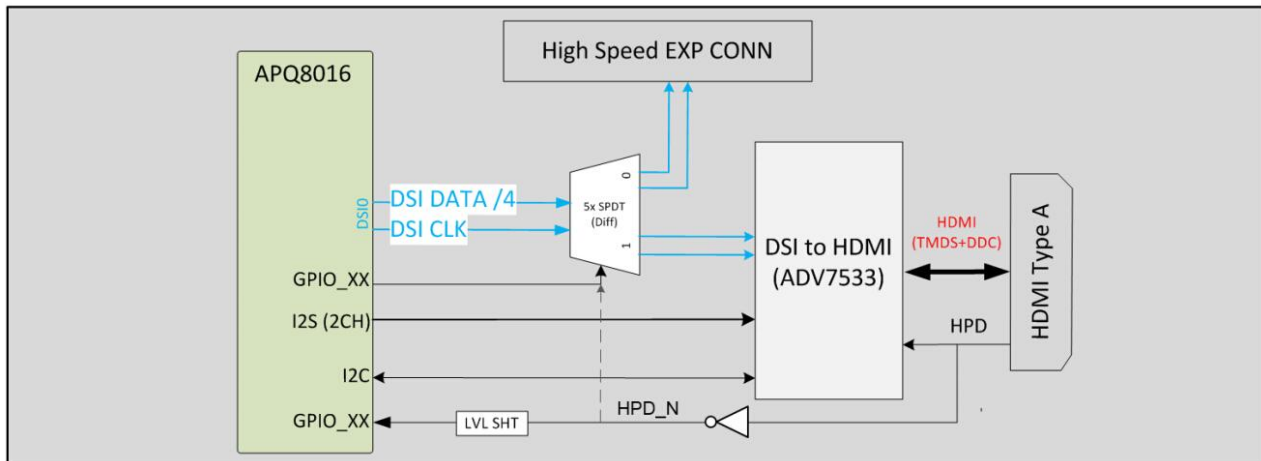

The DB4 deployed Qualcomm's RF chip WCN3620 (U5) solution that integrates three different wireless connectivity technologies into a single device, the interfaces are:

- WLAN compliant with IEEE 802.11 b/g/n specifications, meeting 96Boards minimal requirements for WiFi.
- Bluetooth compliant with the BT specifications version 4.1 (BR/EDT + BLE), meeting the 96Boards requirements for BT
- Worldwide FM radio, this interface is not part of the 96Boards mandatory specification. It is an optional addition that has not been tested is not officially supported.

4.7 Display Interface

4.7.1 HDMI

The 96Boards specification calls for an HDMI port to be present on the board. The APQ8016 doesn't include a built-in HDMI interface. The DB4 deploys the built-in MIPI-DSI 4 lanes interface as the source for the HDMI output. A peripheral DSI to HDMI Bridge (U3, Analog Devices ADV7533) performs this task and it supports a resolution from 480i to 1080p at 30Hz.

While the ADV7533 supports automatic input video format timing detection (CEA-861E), an I2C channel from the APQ8016 allows the user to configure the operation of this bridge. It is I2C3 interface from the SoC that connects to the bridge.

This bridge supports audio as well (meeting the 96Boards requirements to provide audio via HDMI). The DB4 uses a single bit I2S2 interface from the APQ8016 for this task.

Please note that the 96Boards specification calls for a MIPI-DSI interface to be routed to the High Speed Expansion connector. Since the APQ8016 has only one MIPI-DSI interface. A muxing device (U11, FSA644UCX) is being use on the board. Only one interface, HDMI, or the Expansion MIPI-DSI can be active at a given time. The controlling signal is named 'DSI_SW_SEL_APQ'. When this signal is logic low, '0', the MIPI-DSI is routed to the DSI-HDMI Bridge. When 'DSI_SW_SEL_APQ' is logic level high, '1', the MIPI-DSI is routed to the High Speed Expansion connector. This design assigned the 'DSI_SW_SEL_APQ' function to GPIO_32.

User can overwrite the software control by sliding switch 4 of DipSwitch S6 to the 'ON' position. That action forces the DSI mux to route the MIPI-DSI to the DSI-HDMI Bridge. The overwrite option exist for the HDMI only, you cannot hardware overwrite the mux to the High Speed Expansion connector.

4.7.2 MIPI-DSI

The 96Boards specification calls for a MIPI-DSI implementation via the High Speed Expansion Connector.

The DB4 implemented a four-lane MIPI_DSI interface meeting this requirement. More information about this implementation can be found in chapter 6 High speed expansion connector.

4.8 Camera Interfaces

The 96Boards specification calls for two camera interfaces.

The DB4 implements two camera interfaces, one with a four-lane MIPI_CSI interface and one with two-lane MIPI_CSI interface, meeting this requirement. More information about this implementation can be found in chapter 6 High speed expansion connector.

4.9 USB Ports

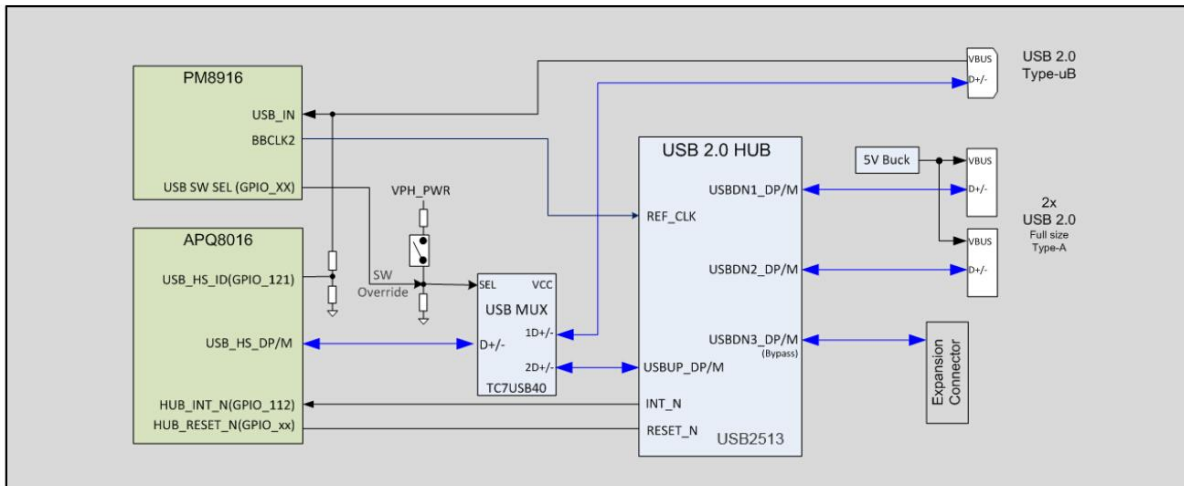

4.9.1 USB-Host ports

The 96Boards specification calls for three USB host ports. The APQ8016 includes a single USBOTG channel. A USB Mux, S1, routes this single USB channel either to a USB HUB or to the MicroUSB connector (J4). The control of S1 is done via a software controlled GPIO (USB_SW_SEL_PM, GPIO_4 from the board PMIC). When this signal is logic low, '0', the USB data lines are routed to the MicroUSB connector and the APQ8016 built-in USBOTG port is set to device mode. When 'USB_SW_SEL_PM' is logic level high, '1', the USB data lines are routed to U10 (a 3-port USB HUB) and the APQ8016 built-in USBOTG port is set to host mode. The user can overwrite the software control by sliding switch 3 of DipSwitch S6 to the 'ON' position. That action forces the USB-mux S1 to route the built-in USBOTG data lines to the USB HUB. The overwrite

option exists for the host mode only, you cannot hardware overwrite the mux to force device mode.

Port 1 of the USB HUB is routed to J3, a Type 'A' USB Host connector. A current limited controller (U4) sets the Power Current limit to 1.18A. This port is named HOST2 in the board schematic.

Port 2 of the USB HUB is routed to J2, a Type 'A' USB Host connector. A current limited controller (U6) sets the Power Current limit to 1.18A. This port is named HOST1 in the board schematic.

Port 3 of the USB HUB is routed to the High Speed Expansion connector. No current limited controller is implemented on the board for this channel.

Please note: *the board can work in one mode at a time, Host mode or Device mode, not both.*

Please note: Since the APQ8016 has only a single USBOTG channel, care needs to be taken when the USB HOST function is to be used. Please verify that no cable is connected to the MicroUSB type B connector (and to a host on the other side of the cable) as the hardware of the DB4 will inform software about the presence of a request to configure the USBOTG to device mode. Depending on the software release that is used on the board, the driver may configure the USB Mux to Device mode and none of the USB HOST ports will be connected to the SoC.

4.9.2 USB-Device port

The 96Boards specification calls for a USB port to be implemented as an OTG port or a device port.

The DB4 implements a device port. The port is located at J4, a MicroUSB type B. If an application requires the use of the device port, USB_SW_SEL_PM signal must be set to low '0' and the user must verify that switch 3 of Dip Switch S6 is set to the 'OFF' position.

Please note: *the board can work in one mode at a time, Host mode or Device mode, not both.*

4.10 Audio

The 96Boards specifications calls for a minimum of single channel audio through two interfaces, BT and HDMI/MHL/DisplayPort..

The DB4 meets this requirement and has additional audio channels. More information about these additional channels can be found in chapter 4.18 Additional Functionality.

4.10.1 BT Audio

The BT implementation on the DB4 is via a MAC in the APQ8016 and an external modem, WCN3620 (U5). A two wire interface between the SoC and the modem carries all communication including audio.

4.10.2 HDMI Audio

A 3-wire (audio out only) I2S channel is routed directly from the APQ8016 SoC I2S interface pins to the DSI-HDMI bridge (U3).

4.11 DC-power and Battery Power

The 96Boards specification calls for power to be provided to the board in one of the following ways:

- An 6.5V to 18V power from a dedicated DC jack
- An 6.5V to 18V power from the SYS_DCIN pins on the Low Speed Expansion Connector
- A USB Type C port at 5V

Please see section 9.1 for detailed information on DB4 implementation of DC Power

4.12 Measurements

The 96Boards specification calls for support for measuring power consumptions of the board.

Please see section 8.6 for detailed information on DB4 power measurement implementation.

4.13 Buttons

The 96Boards specification calls for the present of two buttons, a Power on/sleep button and a Reset button.

The DB4 meets these requirements. Please see section 10 for detailed information on the buttons of the DB4.

4.14 External Fan connection

The 96Boards specification calls for support for an external fan. That can be achieved by using the 5V or the SYS_DCIN, both present on the Low Speed Expansion connector.

4.15 UART

The 96Boards specification calls for support for one SoC UART and an optional second UART both to be routed to the Low Speed Expansion Connector.

The DB4 meets these requirements and additionally routes UART0 Tx/Rx lines to an on-board connector (J15). If the user wants to use this on-board UART, J15 needs to be soldered to the board as well as R173 and R174 (0 ohm 0201).

4.16 JTAG

The 96Boards specification does not call for a dedicated JTAG connector. However the DB4 has JTAG and UART signals routed to J15. The J15 connector does not have a standard JTAG connector pitch and is not populated on the board.

4.17 System and user LEDs

The 96Boards specifications calls for six LEDs to be implemented on the board. The specification defines the LEDs color and mechanical location on the board.

Three activity LEDs:

- WiFi activity LED – DB4 drives this Yellow LED via MPP_2, an IO from the PMIC.
- BT activity LED – DB4 drives this Blue LED via MPP_3, an IO from the PMIC.
- Ethernet activity LED – Ax88772C drives this Green LED.

Four User-LED's:

The four user LEDs are surface mount Green in 0603 size located next to the two USB type A connector and labeled 'USER LED'S 4 3 2 1'. The DB4 drives two LEDs from the SoC GPIO, APQ GPIO_21 and APQ GPIO_120. The other two User LEDs are driven by the PMIC via PM GPIO_1 and PM GPIO_2.

4.18 Expansion Connector

The 96Boards specification calls for two Expansion Connectors, a Low Speed and a High Speed.

The DB4 meets this requirement, please review section 6.0 for detailed information regarding the Low Speed Expansion Connector and section 7.0 for detailed information regarding the High Speed Expansion Connector.

4.19 Additional Functionality

The 96Boards specifications allows for additional functionality provided that all mandatory functionality is available and there is no impact on the physical footprint specifications including height and do not prevent the use of the 96Boards CE low speed and high speed expansion facilities.

The DB4 implements a few additional functions, which are listed in the following sub-chapters.

4.19.1 On Board Analog Microphone

Information on the on board microphone can be found in section 8.2.

4.19.2 Analog Connector

Detailed information on the analog connector is provided in section 8.0.

5 Low speed Expansion connector

The following tables show the Low Speed Expansion Connector pin out:

PIN	96Boards Signals	DB4 Signals	Note
1	GND	GND	
3	UART0_CTS	UART0_CTS_N (APQ GPIO_2)	
5	UART0_TxD	UART0_TX (APQ GPIO_0)	
7	UART0_RxD	UART0_RX (APQ GPIO_1)	
9	UART0_RTS	UART0_RTS_N (APQ GPIO_3)	
11	UART1_TxD	UART1_TX (APQ GPIO_4)	
13	UART1_RxD	UART1_RX (APQ GPIO_5)	
15	I2C0_SCL	I2C0_SCL (APQ GPIO_7)	
17	I2C0_SDA	I2C0_SDA (APQ GPIO_6)	
19	I2C1_SCL	I2C1_SCL (APQ GPIO_23)	
21	I2C1_SDA	I2C1_SDA (APQ GPIO_22)	
23	GPIO-A	LS_EXP_GPIO_A (APQ GPIO_36) (APQ INT)	
25	GPIO-C	LS_EXP_GPIO_C (APQ GPIO_13) (TS_INT_N)	
27	GPIO-E	LS_EXP_GPIO_E (APQ GPIO_115) (GYRO_ACCL_INT)	
29	GPIO-G	LS_EXP_GPIO_G (APQ GPIO_24) (DSI_VSYNC)	
31	GPIO-I	LS_EXP_GPIO_I (APQ GPIO_35) (CSI0_RST)	
33	GPIO-K	LS_EXP_GPIO_K (APQ GPIO_28) (CSI1_RST)	
35	+1V8	LS_EXP_1P8	
37	+5V	SYS_5P0	
39	GND	GND	

PIN	96Boards Signals	DB4 Signals	Note
2	GND	GND	
4	PWR_BTN_N	PHONE_ON_N	
6	RST_BTN_N	PM_RESIN_N	
8	SPIO_SCLK	SPIO_CLK (APQ GPIO_19)	
10	SPIO_DIN	SPIO_MISO (APQ GPIO_17)	
12	SPIO_CS	SPIO_CS_N (APQ GPIO_18)	
14	SPIO_DOUT	SPIO_MOSI (APQ GPIO_16)	
16	PCM_FS	LS_EXP_MI2S_WS (APQ GPIO_110)	
18	PCM_CLK	LS_EXP_MI2S_SCK (APQ GPIO_113) (ALPS_INT)	
20	PCM_DO	LS_EXP_MI2S_DATA0 (APQ GPIO_114)	
22	PCM_DI	N.C.	<i>I2S only supports audio out</i>
24	GPIO-B	LS_EXP_GPIO_B (APQ GPIO_12) (TS_RST_N)	
26	GPIO-D	LS_EXP_GPIO_D (APQ GPIO_69) (MAG_INT)	
28	GPIO-F	LS_EXP_GPIO_F (PM_MPP_4) (DSI_BLCTRL))	<i>Borrowed GPIO from PMIC</i>
30	GPIO-H	LS_EXP_GPIO_H (APQ GPIO_25) (DSI_RST)	
32	GPIO-J	LS_EXP_GPIO_J (APQ GPIO_34) (CSIO_PWDN)	
34	GPIO-L	LS_EXP_GPIO_L (APQ GPIO_33) (CSI1_PWDN)	
36	SYS_DCIN	SYS_DCIN	
38	SYC_DCIN	SYS_DCIN	
40	GND	GND	

5.1 UART {0/1}

The 96Boards specifications calls for a 4-wire UART implementation, UART0 and an optimal second 2-wire UART, UART1 on the Low Speed Expansion Connector.

The DB4 implements UART0 as a 4-wire UART that connects directly to the APQ8016 SoC. These signals are driven at 1.8V.

The DB4 implements UART1 as a 2-wire UART that connects directly to the APQ8016 SoC. These signals are driven at 1.8V.

5.2 I2C {0/1}

The 96Boards specification calls for two I2C interfaces to be implemented on the Low Speed Expansion Connector.

The DB4 implements both interfaces, I2C0 and I2C1 that connects directly to the APQ8016SoC. A 2K resistor is provided as pull-up for each of the I2C lines per the I2C specifications, these pull-ups are connected to the 1.8V voltage rail.

5.3 GPIO {A-L}

The 96Boards specifications calls for 12 GPIO lines to be implemented on the Low Speed Expansion Connector. Some of these GPIOs may support alternate functions for DSI/CSI control

The DB4 implements this requirement. 11 GPIOs are routed to the APQ8016 SoC and one GPIO is connected to the on-board PMIC.

- GPIO A - Connects to GPIO_36 of APQ8016 SoC, can serves as AQP_INT supporting the 96Boards requirements to create a wake-up event for the SoC. It is a 1.8V signal
- GPIO B - Connects to GPIO_12 of APQ8016 SoC. It is a 1.8V signal
- GPIO C - Connects to GPIO_13 of APQ8016 SoC. It is a 1.8V signal. Can be configured to be an IRQ line
- GPIO D - Connects to GPIO_69 of APQ8016 SoC. It is a 1.8V signal. Can be configured to be an IRQ line
- GPIO E - Connects to GPIO_115 of APQ8016 SoC. It is a 1.8V signal. Can be configured to be an IRQ line
- GPIO F - Connects to MPP_4 of PM8916 PMIC. It is a 1.8V signal. Can be configured to be the DSI backlight control
- GPIO G - Connects to GPIO_24 of APQ8016 SoC. It is a 1.8V signal. Can be configured to be DSI VSYNC signal.
- GPIO H - Connects to GPIO_25 of APQ8016 SoC. It is a 1.8V signal. Can be configured to be a DSI_RST signal.
- GPIO I - Connects to GPIO_35 of APQ8016 SoC. It is a 1.8V signal. Can be configured to be a CSIO_RST signal.
- GPIO J - Connects to GPIO_34 of APQ8016 SoC. It is a 1.8V signal. Can be configured to be a CSIO_PWDN signal.
- GPIO K - Connects to GPIO_28 of APQ8016 SoC. It is a 1.8V signal. Can be configured to be a CSI1_RST signal.
- GPIO L - Connects to GPIO_33 of APQ8016 SoC. It is a 1.8V signal. Can be configured to be a CSI1_PWDN signal.

5.4 SPI 0

The 96Boards specification calls for one SPI bus master to be provided on the Low Speed Expansion Connector.

The DB4 implements a full SPI master with 4 wires, CLK, CS, MOSI and MISO all connect directly to the APQ8016 SoC. These signals are driven at 1.8V.

5.5 PCM/I2S

The 96Boards specification calls for one PCM/I2S bus to be provided on the Low Speed Expansion Connector. The CLK, FS and DO signals are required while the DI is optional.

The DB4 implements a PCM/I2S with 3 wires, CLK, FS and DO, the optional DI signal is not implemented on the DB4 board. The I2S signals are connected directly to the APQ8016 SoC. These signals are driven at 1.8V.

5.6 Power and Reset

The 96Boards specification calls for a signal on the Low Speed Expansion Connector that can power on/off the board and a signal that serves as a board reset signal.

The DB4 routes the PWR_BTN_N (named PHONE_ON_N on DB4 schematic) signal to the KYPD_PWR_N pin of the PM8916 PMIC.

This signal is driven by S2 as well, the on-board power on push-button switch. Please note that the push button only provides an On/Sleep function and not OFF functionality.

A mezzanine implementation of this signals should not drive it with any voltage, the only allowed operation is to force it to GND to start the board from a sleep mode. A board shutdown will occur when this signal is held to ground for more than 15 seconds (based on the current Android release).

The DB4 routes the RST_BTN_N (named PM_RESIN_N on DB4 schematic) signal to the RESIN_N pin of the PM8916 PMIC. This signal is driven by S4, the on-board reset switch. This signals is a dual purpose, any press lasting less than 10 seconds serves as Volume Down or Zoom out, a press longer than 10 seconds will reset the board.

5.7 Power Supplies

The 96Boards specification calls for three power rails to be present on the Low Speed Expansion Connector:

- +1.8V : Max of 100mA
- +5V : Able to provide a minimum of 5W of power (1A).
- SYS_DCIN : 9-18V input with enough current to support all the board functions or the output DCIN from on-board DC Connector able to provide a minimum of 7W of power.

The DB4 supports these requirements as follows:

+1.8V : Driven by two PMIC LDOs, LDO15 and LDO16, each can provide 55mA. The PM8916 allows connecting the two LDOs in parallel to provide 110mA on a 1.8V rail which meets the 96Boards requirement.

+5V : Driven by the 4A 5.0V buck switcher (U13). This buck switcher powers both USB limit current devices (each at 1.18A max). The remaining capacity provides a max current of 1.64A to the Low Speed Expansion Connector, for a total of 8.2W which meets the 96Boards requirements.

SYS_DCIN: Can serves as the board's main power source or can receive power from the board.

6 High speed expansion connector

PIN	96Boards Signals	DB4 Signals	Note
1	SD_DAT0/SPI1_DOUT	SPI1_MOSI (APQ GPIO_8)	<i>This is a SPI implementation. not an SD interface</i>
3	SD_DAT1	N.C.	
5	SD_DAT2	N.C.	
7	SD_DAT3/SPI1_CS	SPI1_CS_N (APQ GPIO_10)	
9	SD_SCLK/SPI1_SCLK	SPI1_CLK (APQ GPIO_11)	
11	SD_CMD/SPI1_DIN	SPI1_MISO (APQ GPIO_9)	
13	GND	GND	
15	CLK0/CSI0_MCLK	CSI0_MCLK (APQ GPIO_26)	
17	CLK1/CSI1_MCLK	CSI1_MCLK (APQ GPIO_27)	
19	GND	GND	
21	DSI_CLK+	MIPI_DSIO_CLK_P_EXP_CONN	
23	DSI_CLK-	MIPI_DSIO_CLK_M_EXP_CONN	
25	GND	GND	
27	DSI_D0+	MIPI_DSIO_DATA0_P_EXP_CONN	
29	DSI_D0-	MIPI_DSIO_DATA0_M_EXP_CONN	
31	GND	GND	
33	DSI_D1+	MIPI_DSIO_DATA1_P_EXP_CONN	
35	DSI_D1-	MIPI_DSIO_DATA1_M_EXP_CONN	
37	GND	GND	
39	DSI_D2+	MIPI_DSIO_DATA2_P_EXP_CONN	
41	DSI_D2-	MIPI_DSIO_DATA2_M_EXP_CONN	
43	GND	GND	
45	DSI_D3+	MIPI_DSIO_DATA3_P_EXP_CONN	
47	DSI_D3-	MIPI_DSIO_DATA3_M_EXP_CONN	
49	GND	GND	
51	USB_D+	USB_HS_D_P_EXP	<i>No HSIC implementation</i>
53	USB_D-	USB_HS_D_M_EXP	
55	GND	GND	
57	HSIC_STR	N.C.	
59	HSIC_DATA	N.C.	

The following table shows the High Speed Expansion Connector pin out:

PIN	96Boards Signals	DB4 Signals	Note
2	CSI0_C+	MIPI_CSI0_CLK_P	
4	CSI0_C-	MIPI_CSI0_CLK_M	
6	GND	GND	
8	CSI0_D0+	MIPI_CSI0_DATA0_P	
10	CSI0_D0-	MIPI_CSI0_DATA0_M	
12	GND	GND	
14	CSI0_D1+	MIPI_CSI0_DATA1_P	
16	CCSI0_D1-	MIPI_CSI0_DATA1_M	
18	GND	GND	
20	CSI0_D2+	MIPI_CSI0_DATA2_P	
22	CSI0_D2-	MIPI_CSI0_DATA2_M	
24	GND	GND	
26	CSI0_D3+	MIPI_CSI0_DATA3_P	
28	CSI0_D3	MIPI_CSI0_DATA3_M	
30	GND	GND	
32	I2C2_SCL	I2C2_SCL (APQ GPIO_30)	
34	I2C2_SCL	I2C2_SDA (APQ GPIO_29)	
36	I2C3_SDA	I2C3_SCL (APQ GPIO_15)	
38	I2C3_SDA	I2C3_SDA (APQ GPIO_14)	
40	GND	GND	
42	CSI1_D0+	MIPI_CSI1_DATA0_P	
44	CSI1_D0-	MIPI_CSI1_DATA0_M	
46	GND	GND	
48	CSI1_D1+	MIPI_CSI1_DATA1_P	
50	CSI1_D1-	MIPI_CSI1_DATA1_M	
52	GND	GND	
54	CSI1_C+	MIPI_CSI1_CLK_P	
56	CSI1_C-	MIPI_CSI1_CLK_M	
58	GND	GND	
60	RESERVED	N.C.	

*R61 & R62 need to be
Installed to enable I2C3*

6.1 MIPI DSI 0

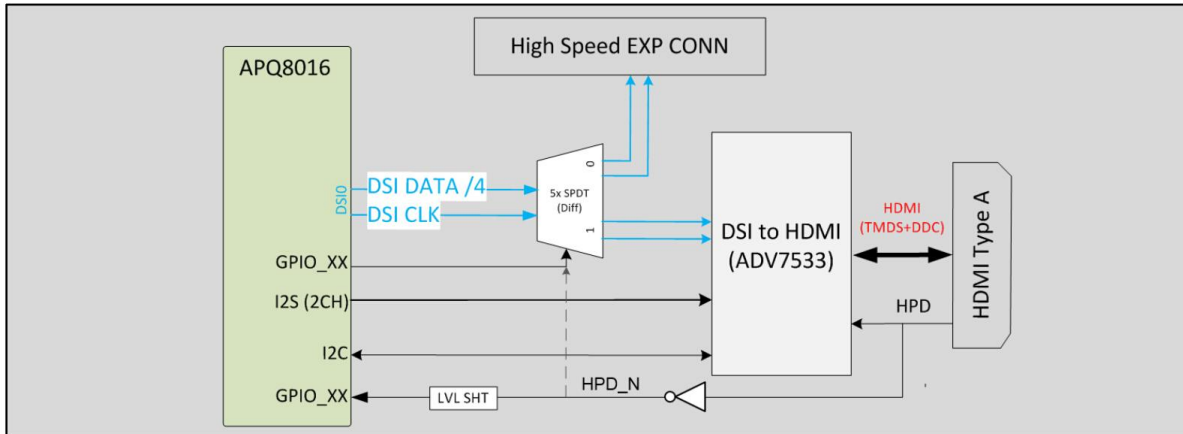

The 96Boards specification calls for a MIPI-DSI to be present on the High Speed Expansion Connector. A minimum of one lane is required and up to four lanes can be accommodated on the connector.

The DB4 implementation supports a full four lane MIPI-DSI interface that is routed to the High Speed Expansion Connector. Since the APQ8016 has only single MIPI-DSI interface and it may be used to drive the DSI-HDMI Bridge, DSI muxing is required.

A muxing device, U11 (FSA644UCK) is used on the board. Only one interface, HDMI, or the Expansion MIPI-DSI can be active at a given time. The controlling signal is named 'DSI_SW_SEL_APQ'. When this signal is logic low, '0', the MIPI-DSI is routed to the DSI-HDMI Bridge.

When 'DSI_SW_SEL_APQ' is logic level high, '1', the MIPI-DSI is routed to the High Speed Expansion connector. This design assigned the 'DSI_SW_SEL_APQ' function to GPIO_32.

The user can override the software control by sliding switch 4 of DipSwitch S6 to the 'ON' position. That action forces the DSI mux to route the MIPI-DSI to the DSI-HDMI Bridge. The override option exists for HDMI only. You cannot force the mux to the High Speed Expansion connector. While hardware forces the ESI Mux to the HDMI, software must configure the HDMI bridge for proper functionality.

Please note: If configuring the board to use the MIPI-DSI is done via software, the user must verify the switch 4 of DipSwitch S6 is set to the 'off' position

6.2 MIPI CSI {0/1}

The 96Boards specification calls for two MIPI-CSI interfaces to be present on the High Speed Expansion Connector. Both interfaces are optional. CSI0 interface can be up to four lanes while CSI1 is up to two lanes.

The current DB4 implementation supports a full four lane MIPI-CSI interface on CSI0 and two lanes of MIPI-CSI on CSI1. All MIPI-CSI signals are routed directly to/from the APQ8016.

6.3 I2C {2/3}

The 96Boards specification calls for two I2C interfaces to be present on the High Speed Expansion Connector. Both interfaces are optional unless a MIPI-CSI interface has been implemented. Then an I2C interface shall be implemented.

The current DB4 implementation supports two MIPI-CSI interfaces and therefore must support two I2C interfaces.

For MIPI-CSI0 the companion I2C2 is routed directly from the APQ8016. For MIPI-CSI1, the companion I2C is I2C3.

Note: You will need to add R61 and R62, 0 ohm 0201 resistors, to the board to support the routing of I2C3 interface to the High Speed Expansion Connector. Both interfaces, I2C2 and I2C3 have an on-board 2K pull-up resistors pulled-up to the

1.8V voltage rail.

6.4 HSIC

The 96Boards specification calls for an optional MIPI-HSIC interface to be present on the High Speed Expansion Connector.

The DB4 implementation doesn't support this optional requirement.

6.5 Reserved

The 96Boards specification calls for a 10K pull-up to 1.8V to be connected to pin 60 of the High Speed Expansion Connector.

The current DB4 implementation does not support this requirement. This issue will be addressed on a future revision of the DB4.

6.6 SD/SPI

The 96Boards specification calls for an SD interface or a SPI port to be part of the High Speed Expansion Connector.

The DB4 implements a full SPI master with 4 wires (96Boards SPI Configuration), CLK, CS, MOSI and MISO all connect directly to the APQ8016 SoC. These signals are driven at 1.8V.

6.7 Clocks

The 96Boards specification calls for one or two programmable clock interfaces to be provided on the High Speed Expansion Connector. These clocks may have a secondary function of being CSIO_MCLK and CSI1_MCLK. If these clocks can't be supported by the SoC than an alternative GPIO or No-Connect is allowed by the specifications.

The DB4 implements two CSI clocks, CSIO_MCLK via APQ GPIO_26 and CSI1_MCLK via APQ GPIO_27. These signals are driven at 1.8V.

6.8 USB

The 96Boards specification calls for a USB Data line interface to be present on the High Speed Expansion Connector.

The DB4 implements this requirements by routing USB channel 3 from the USB HUB to the High Speed Expansion Connector.

7 Analog Expansion Connector

PIN	Function	Connect to	Note
1	SPKR_OUT_P	PM8916 Audio signal CDC_SPKDRV_P	Datasheet pin SPKR_DRV_P
2	SPKR_OUT_M	PM8916 Audio signal CDC_SPKDRV_M	Datasheet pin SPKR_DRV_M
3	VPH_PWR	A 3.7V from U12 buck switcher	
4	GND		
5	GND_CFILT	PM8916 Audio signal CDC_GND_CFILT	
6	CDC_MIC2_P	PM8916 Audio signal CDC_IN2_P	Datasheet pin MIC2_IN
7	CDC_MIC3_P	PM8916 Audio signal CDC_IN3_P	Datasheet pin MIC3_IN
8	CDC_HPH_R	PM8916 Audio signal CDC_HPH_R	
9	CDC_HPH_REF	PM8916 Audio signal CDC_HPH_REF	
1	CDC_HPH_L	PM8916 Audio signal CDC_HPH_L	
0	CDC_HS_DET	PM8916 Audio signal CDC_HS_DET	
11	CDC_MIC_BIAS1	PM8916 Audio signal CDC_MIC_BIAS1	
12	N.C.		
13	N.C.		
14	N.C.		
15	FM_RX_ANT	WCN3620 RF signal FM_HS_RX	
16	N.C.		

7.1 Speaker

The speaker signals are routed from the PM8916 PMIC built-in Audio CODEC, the two signals are:

- SKPR_DRV_P - Class-D speaker amplifier output+
- SKPR_DRV_M - Class-D speaker amplifier output-

7.2 Mic

The microphone signals are rounded to the PM8916 PMIC Built-In CODEC, the three signals are:

- MIC2_IN - Headset mic
- MIC3_IN - Second mic, please note that the first microphone input, MIC1_IN is routed from an on-board analog microphone (not installed on current DB4 builds)
- MIC_BIAS1 - Ground reference for PMIC bias

7.3 Headset

The headset signals are rounded from the PM8916 PMIC Built-In CODEC, one signal is routed from the connector to the CODEC, the singles are:

- HPH_R - Headphone PA right channel output
- HPH_L - Headphone PA left channel output
- HPH_REF - Headphone PA ground sensing
- HS_DET - Headset detection

7.4 FM Antenna

The FM_RX_ANT signal is the path for the FM antenna to reach the WCN3620 (u5), an integrated three different connectivity technologies device:

- WLAN IEEE802.11 b/g/n
- BT 4.0 (BR/EDR/BLE)
- Worldwide FM radio

8 Power management

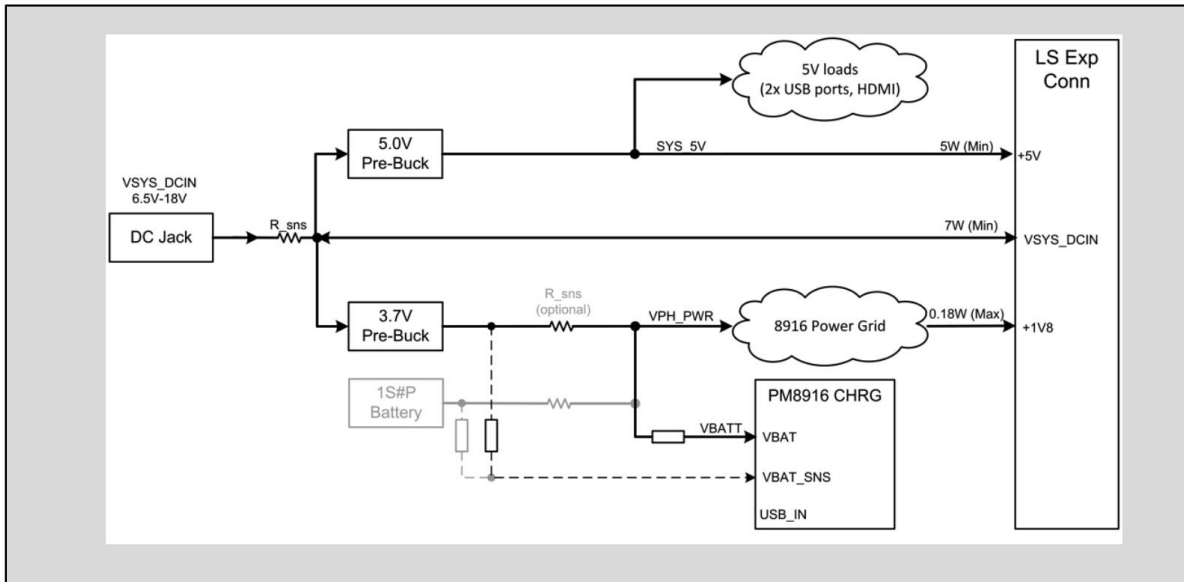

The 96Boards specification defines how power arrives to the board and few supplies that the board needs to provide. The on board power requirement for each 96Boards implementation depends on the SoC and the set of peripherals that are specific to that implementation.

The DB4 uses two buck regulators, U13 and U12. U13 takes the power in to the board and generates 5V at 4A. This voltage feeds the USB HOST power limit switches and provides power to the Low Speed Expansion port. U12 takes the power in to the board and generates 3.7V at 4A. This voltage serves as the power in voltage to the on-board PMIC, PM8916 (U9). The PM8916 can generate 25 different voltage rails.

8.1 DC Power Input

The 96Boards specification calls for a power to be provided to the board in one of the following ways:

- An 8V to 18V power from a dedicated DC jack.
The DB4 supports this requirement through the use of J1, 'SYS_DCIN' power connector.
Please note: the SYS_DCIN can be as low as 6.5V on the DB4.
- An 8V to 18V power from the SYS_DCIN pins on the Low Speed Expansion Connector.
Please note: the SYS_DCIN can be as low as 6.5V on the DB4.
The DB4 supports incoming power through this connector.
- A USB Type C port at 5V.
Please note: **The DB4 does not implement a USB Type C port and therefore cannot be powered over USB.**

8.2 Power Source Selection

Following the information in section 9.1, the DB4 has only two sources for board incoming power. The 96Boards specification calls for only one power source to be applied to the board at any given time. Following this requirement, **the user of the DB4 should never apply power to the board from J1 and the Low Speed Expansion connector at the**

same time. There is no active or passive mechanism on the DB4 to prioritize one source over the other.

8.3 Power Consumption

The power consumption of DB4 will be less than 5W.

8.4 Power Sequencing

Upon applying power to the DB4 (either one of the two sources), both buck regulators will be enabled and will start regulating their target voltages. When the output of U12 is on, it will power the on-board PMIC, the PM8916. This PMIC has four buck regulators, one boost regulator and 20 LDOs. The sequencing of all power rails is set within the PM8916 configuration scheme during the production of this part. The user has no access to alter, modify or change the PMIC power up sequencing.

8.5 Voltage Rails

Please see section 10 for detailed list of the power rails on the DB4.

8.6 Power Measurements

The 96Boards specification calls for a minimum of one current sense resistor to be placed on the board permitting a basic power measurement functions.

The DB4 implements two different power measurements.

8.6.1 Power-In measurement

A 0.1ohm resistor is placed inline to the SYS_DCIN power line coming from J1 (please note that this power in measurement only works for SYS_DCIN from J1, it will not measure SYS_DCIN applied from the Low Speed Expansion Connector). Placing a probe over this resistor will provide a voltage measurement of the voltage drop across the resistor. Dividing this measurement by 0.1 will give you the amount of the current flowing into the board. The board provides a means to use ARM Energy probe for this measurement, please verify that JP3 and JP4 are each shorted and J10 is soldered to the board to take advantage of this probe.

8.6.2 PMIC Power-In measurement

A 0.1ohm resistor should replace the existing inline 0 ohm resistor on VPH_PWR line, the output of U12 buck regulator that feeds the PMIC. Placing a probe over this resistor will provide a voltage measurement of the voltage drop across the resistor. Dividing this value by 0.1 will give you the amount of the current flowing into the PMIC. The board provides a means to use an ARM Energy probe for this measurement, the following steps are required to get this probe measuring this rail:

1. **Remove R122 and R123 from the board to prevent a short between SYS_DCIN and VPH_PWR**
2. J10 needs to be soldered to the board.
3. R124 and R125, 0 ohm 0201 resistors, need to be soldered to the board.

9 Buttons and status LED's

9.1 Buttons

9.1.1 Volume up

The Volume UP button is used to control the output speaker volume of the DB4.

9.1.2 Volume down

The Volume Down button is used to control the output speaker volume of the DB4.

9.1.3 Power Button

The push-button S2 serves as the power-on/sleep button. Upon applying power to the board, the boot process will start. Once the board is running you can turn power-off by pressing the power button for more than **x** seconds. If the board is in a sleep mode, pressing the power button for more than 3 seconds will wake up the board.

9.1.4 Reset Button

The on-board S4 push-button has two functions, it serves as a reset button and as a Volume/Zoom- button.

A button press with duration of less than 10 second will be interpreted by software as a volume down or zoom out request. Duration of more than 10 seconds will cause a system reset.

9.2 LED's

There are two status LEDs and four User LEDs on the DB4. The Status LEDs report the status of the Bluetooth and Wi-Fi devices onboard. The user LEDs are driven by the SoC directly.

9.2.1 User LED 1-4

The four user LEDs are surface mount Green LED, 0603 size, located next to the two USB type A connector and labeled 'USER LED 4 3 2 1'.

9.2.2 Bluetooth status

The BT LED on the DB4 is located next to the USBOTG connector; this LED reflects the status of the Bluetooth device.

9.2.3 WiFi status

The WIFI LED on the DB4 is located beside the BT LED, this LED reflects the status of the Wi-Fi device.

9.2.4 Ethernet status

The Ethernet LED on the DB4 is located beside the User LED, this LED reflects the status of the Ethernet status.

10 Boot configuration

There is a 4 switch DipSwitch marked S6 located at the bottom side of the DB4. For normal operation all four switched need to be set to the 'off' position.

Switch 1, 'USB BOOT', when set to 'on' position, will force boot over USB connection with a PC. This is only required for eMMC boot image upgrade. Please review the proper OS User Guide for more information on this process.

Switch 2, 'SD BOOT', when set to 'on' position, will force the μ SD, J5, to serve as the boot source for the DB4 when set. You can use uSD as the main boot source or it can serve as a method for eMMC boot image upgrade. Please review the proper OS User Guide for more information on this process.

Switch 3, 'USB HOST', is described in section 5.8. This switch is not part of the boot configuration.

Switch 4, 'HDMI SEL', is described in section 5.6.1. This switch is not part of the boot configuration.

FCC warning

This equipment has been tested and found to comply with the limits for a Class B digital device, pursuant to Part 15 of the FCC rules. These limits are designed to provide reasonable protection against harmful interference in a residential installation. This equipment generates, uses and can radiate radio frequency energy and, if not installed and used in accordance with the instructions, may cause harmful interference to radio or television reception, which can be determined by turning the equipment off and on.

The user is encouraged to try to correct the interference by one or more of the following measures.

- Reorient or relocate the receiving antenna.
- Increase the separation between the equipment and receiver.
- Consult the dealer or an experienced radio/TV technician for help.
- This class B digital product meets all requirements of the Canadian Interference - Causing Equipment Regulations.

This equipment complies with FCC radiation exposure limits set forth for an uncontrolled environment. This equipment should be installed and operated with minimum distance 20cm between the radiator & your body.

You are cautioned that changes or modifications not expressly approved by the party responsible for compliance could void your authority to operate the equipment.

The distance between user and products should be no less than 20cm