

Genie®



Operator's Manual *with Maintenance Information*

Third Edition
First Printing
Part No. 114002

AWP™ Super Series™

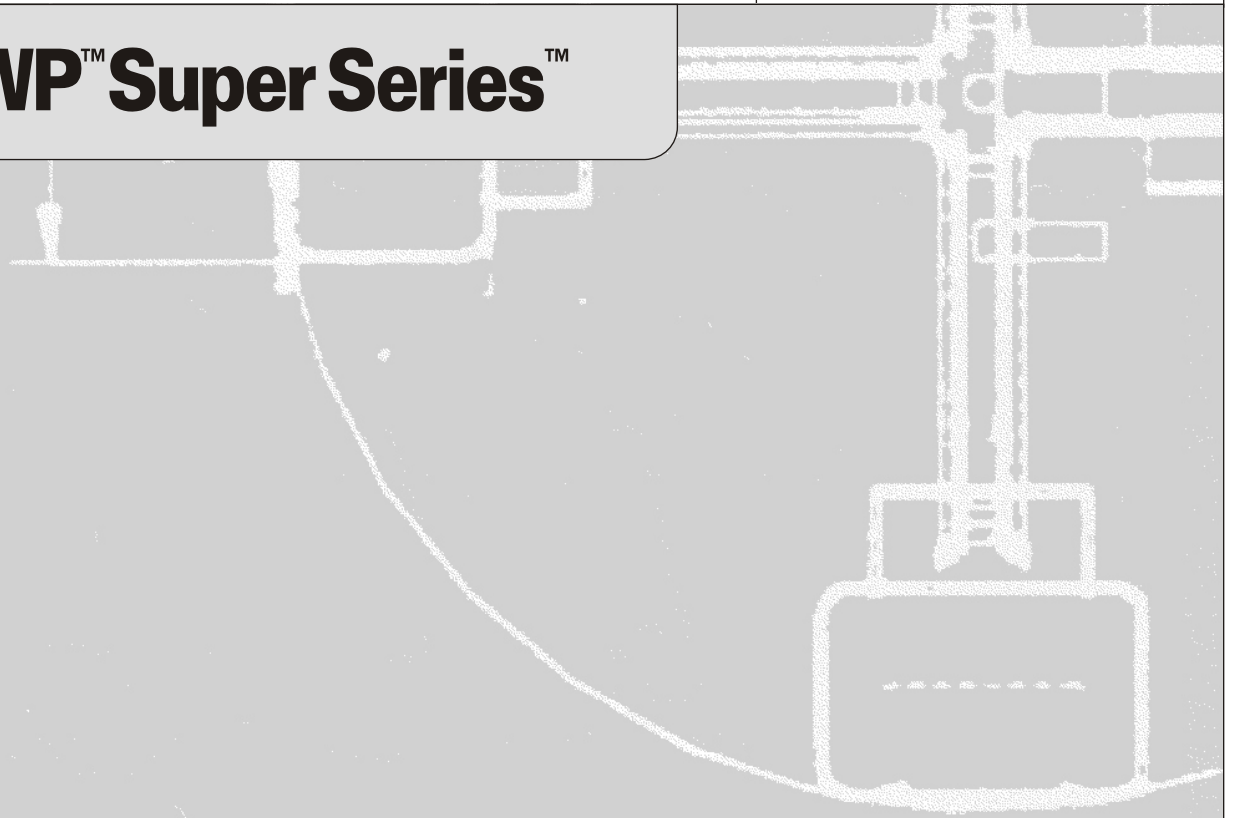

Important

Read, understand and obey these safety rules and operating instructions before operating this machine. Only trained and authorized personnel shall be permitted to operate this machine. This manual should be considered a permanent part of your machine and should remain with the machine at all times. If you have any questions, call Genie Industries.

Contents

	Page
Safety Rules	1
Controls	8
Legend	9
Pre-operation Inspection	10
Maintenance	12
Function Tests	15
Workplace Inspection	18
Operating Instructions	19
Battery Charging Instructions	21
Transport Instructions	22
Tilt-back Operation Instructions	25
Decals	28
Specifications	32

Contact us:

Internet: <http://www.genielift.com>
 e-mail: techpub@genieind.com

Copyright © 1996 by Genie Industries

First Edition: Eighth Printing, October 2001

Second Edition: Second Printing, April 2004

Third Edition: First Printing, August 2005

"Genie" and "AWP" are registered trademarks of Genie Industries in the U.S.A. and many other countries. "Super Series" is a trademark of Genie Industries.

This machine complies with
ANSI/SIA 92.3-1990.

 Printed on recycled paper

Printed in U.S.A.

Safety Rules



Danger

Failure to obey the instructions and safety rules in this manual will cause death or serious injury.

Do Not Operate Unless:

- You learn and practice the principles of safe machine operation contained in this operator's manual.

1 Avoid hazardous situations.

Know and understand the safety rules before going on to the next section.

- 2 Always perform a pre-operation inspection.
- 3 Always perform function tests prior to use.
- 4 Inspect the workplace.
- 5 Only use the machine as it was intended.

- You read, understand and obey the manufacturer's instructions and safety rules—safety and operator's manuals and machine decals.
- You read, understand and obey employer's safety rules and worksite regulations.
- You read, understand and obey all applicable governmental regulations.
- You are properly trained to safely operate the machine.
- The first time this machine is set up for use, a breather cap is installed. See Pre-operation Inspection section.

SAFETY RULES

Electrocution Hazards

This machine, even with an optional fiberglass platform, is not electrically insulated and will not provide protection from contact with or proximity to electrical current.

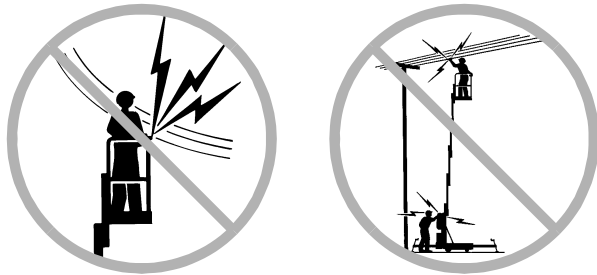

Keep away from the machine if it contacts energized power lines or becomes electrically charged. Personnel on the ground or in the platform must not touch or operate the machine until energized power lines are shut off.

Maintain safe distances from electrical power lines and apparatus in accordance with applicable governmental regulations and the following chart.

Voltage Phase to Phase	Minimum Safe Approach Distance	
	Feet	Meters
0 to 300V	Avoid Contact	
300V to 50KV	10	3.05
50KV to 200KV	15	4.60
200KV to 350KV	20	6.10
350KV to 500KV	25	7.62
500KV to 750KV	35	10.67
750KV to 1000KV	45	13.72

Allow for platform movement, electrical line sway or sag and movement due to strong or gusty winds.

Do not use the machine as a ground for welding.

Do not operate an AC powered machine or a DC battery charger unless using a 3-wire grounded extension cord connected to a grounded AC circuit. Do not alter or disable 3-wire grounded plugs.

Tip-over Hazards

Do not raise the platform unless the base is level, all four outriggers are properly installed and the leveling jacks firmly contact the floor.

Do not adjust or remove the outriggers while the platform is occupied or raised.

Do not move the machine while the platform is raised.

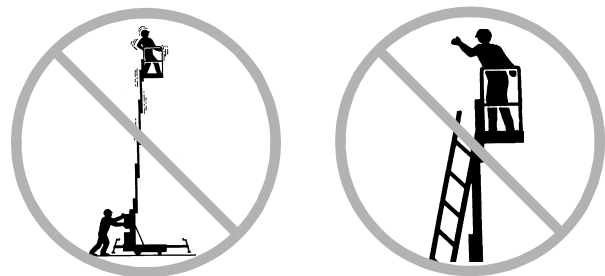

Do not place ladders or scaffolds in the platform or against any part of this machine.

Do not place or attach overhanging loads to any part of this machine.

Do not transport tools and materials unless they are evenly distributed and can be safely handled by the person in the platform.

SAFETY RULES

Do not raise the platform unless the machine is level. Do not set the machine up on a surface where it cannot be leveled using only the leveling jacks.

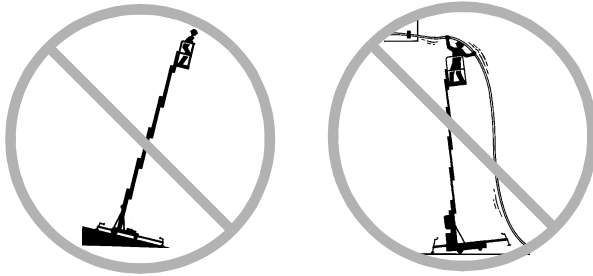

Do not cause a horizontal force or side load to the machine by raising or lowering a fixed or overhanging load.

Do not push off or pull toward any object outside the platform.

Maximum allowable side force

ANSI / CSA
50 lbs / 222 N

Maximum allowable manual force

CE / AUS
45 lbs / 200 N



Do not operate the machine near drop-offs, holes, bumps, debris, unstable or slippery surfaces or other possible hazardous conditions.

Do not alter or disable machine components that in any way affect safety and stability.

Do not replace items critical to stability with items of different weight or specification. Use only Genie authorized replacement parts.

Do not push the Genie AWP from the platform side

of the machine.

When moving the machine with a forklift or other transport vehicle, the platform should be fully lowered, the machine should be turned off and no personnel shall remain in the platform.

Do not use the machine on a moving or mobile surface or vehicle.

Do not raise the platform when wind speeds may exceed 28 mph / 12.5 m/s. If wind speeds exceed 28 mph / 12.5 m/s when platform is raised, lower the platform and do not continue to operate the machine.

Do not operate the machine in strong or gusty winds. Do not increase the surface area of the platform or the load. Increasing the area exposed to the wind will decrease machine stability.

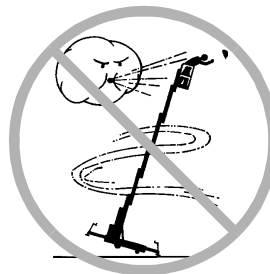

Occupants, equipment and materials shall not exceed the maximum platform capacity.

Maximum capacity

AWP-20S	350 lbs	159 kg
AWP-25S	350 lbs	159 kg
AWP-30S	350 lbs	159 kg
AWP-36S	350 lbs	159 kg
AWP-40S	300 lbs	136 kg

Maximum occupancy

1 person

SAFETY RULES

Fall Hazards

The guard rail system provides fall protection. If occupants of the platform are required to wear personal fall protection equipment (PFPE) due to job site or employer rules, PFPE equipment and its use shall be in accordance with the PFPE manufacturer's instructions and applicable governmental requirements.



Do not sit, stand or climb on the platform guard rails. Maintain a firm footing on the platform floor at all times.

Do not exit the platform while raised. If a power failure occurs, have ground personnel activate the manual lowering valve.

Keep the platform floor clear of debris.

Lower the platform entry mid-rail or gate before operating.

Collision Hazards

Operators must comply with employer, job site and governmental rules regarding the use of personal protective equipment.

Check the work area for overhead obstructions or other possible hazards.



Be aware of crushing hazard when grasping the platform guard rail.



Do not lower the platform unless the area below is clear of personnel and obstructions.



Use common sense and planning to control the movement of the machine on or near inclines.

Stay clear of descending platform.

SAFETY RULES

Improper Use Hazard

Do not leave the machine unattended unless the key is removed to secure from unauthorized use.

Bodily Injury Hazard

Do not operate the machine with a hydraulic oil or air leak. An air leak or hydraulic leak can penetrate and/or burn skin.

Explosion and Fire Hazard

Do not operate the machine or charge the battery in hazardous locations or locations where potentially flammable or explosive gases or particles may be present.

Damaged Machine Hazards

Do not use a damaged or malfunctioning machine.

Be sure all maintenance has been performed as specified in this manual and the Genie AWP Super Series service manual.

Be sure all decals are in place and legible.

Be sure the operator's, safety and responsibilities manuals are complete, legible and in the storage container located on the platform.

Conduct a thorough pre-operation inspection of the machine and test all functions before each work shift. Immediately tag and remove from service a damaged or malfunctioning machine.

Do not use the machine as a ground for welding.

SAFETY RULES

Battery and Charger Safety - DC Models

Burn Hazards

Batteries contain acid. Always wear protective clothing and eye wear when working with batteries.

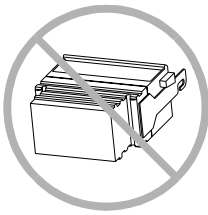

Avoid spilling or contacting battery acid. Neutralize battery acid spills with baking soda and water.

The battery pack must remain in an upright position.

Explosion Hazards



Batteries emit explosive gas. Keep sparks, flames and lighted tobacco away from the battery.

Charge the battery in a well-ventilated area.

Do not disconnect charger DC output wires from the battery when the charger is on.

Electrocution Hazards



Connect the charger to a grounded AC circuit only.

Do not expose the battery or charger to water or rain.

Before each use, inspect for damage. Replace damaged components before operating.

Lifting Hazard

The battery pack weighs 90 lbs / 40.8 kg. Use the appropriate number of people and proper lifting techniques when lifting the battery pack.

SAFETY RULES

Decal Legend

Genie product decals use symbols, color coding and signal words to identify the following:



Safety alert symbol—used to alert personnel to potential personal injury hazards. Obey all safety messages that follow this symbol to avoid possible injury or death.



Red—used to indicate the presence of an imminently hazardous situation which, if not avoided, will result in death or serious injury.



Orange—used to indicate the presence of a potentially hazardous situation which, if not avoided, could result in death or serious injury.



Yellow with safety alert symbol—used to indicate the presence of a potentially hazardous situation which, if not avoided, may cause minor or moderate injury.



Yellow without safety alert symbol—used to indicate the presence of a potentially hazardous situation which, if not avoided, may result in property damage.



Green—used to indicate operation or maintenance information.

Controls

Ground Controls - AC and DC Models

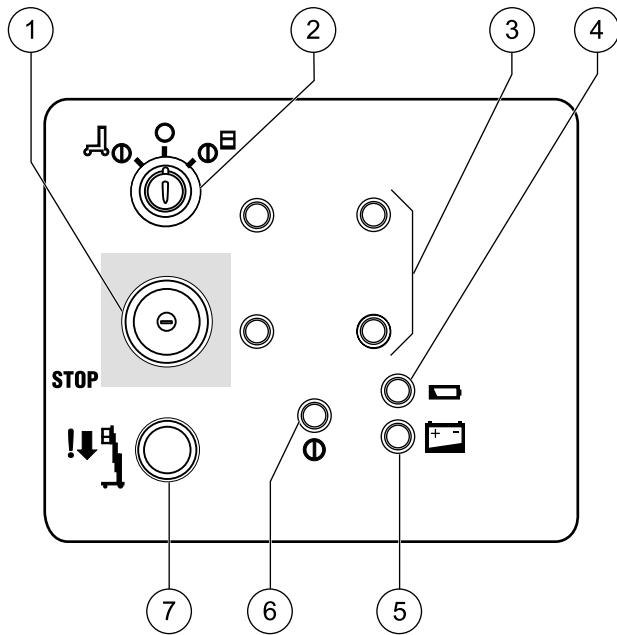

Ground Controls - Air Models

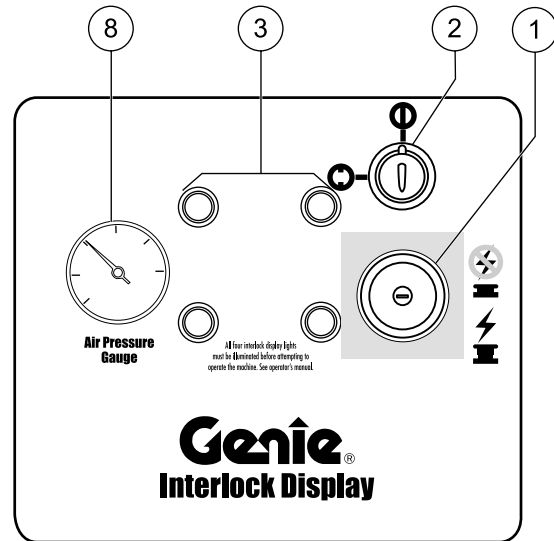

Platform Controls

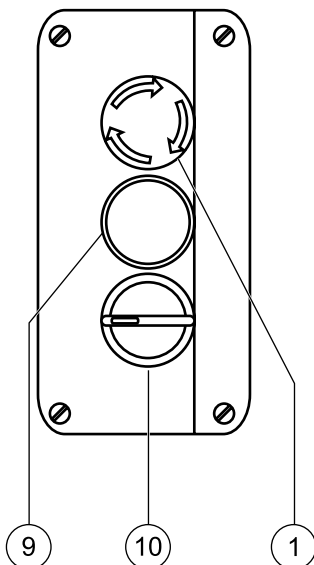

- 1 Red Emergency Stop button
- 2 Key switch
- 3 Outrigger interlock display lights (four)
- 4 Low battery indicator light for auxiliary lowering
- 5 DC models: Low battery indicator light
- 6 Power light
- 7 Auxiliary platform lowering button
- 8 Air pressure gauge
- 9 Control activate button
- 10 Up/Down switch

Legend

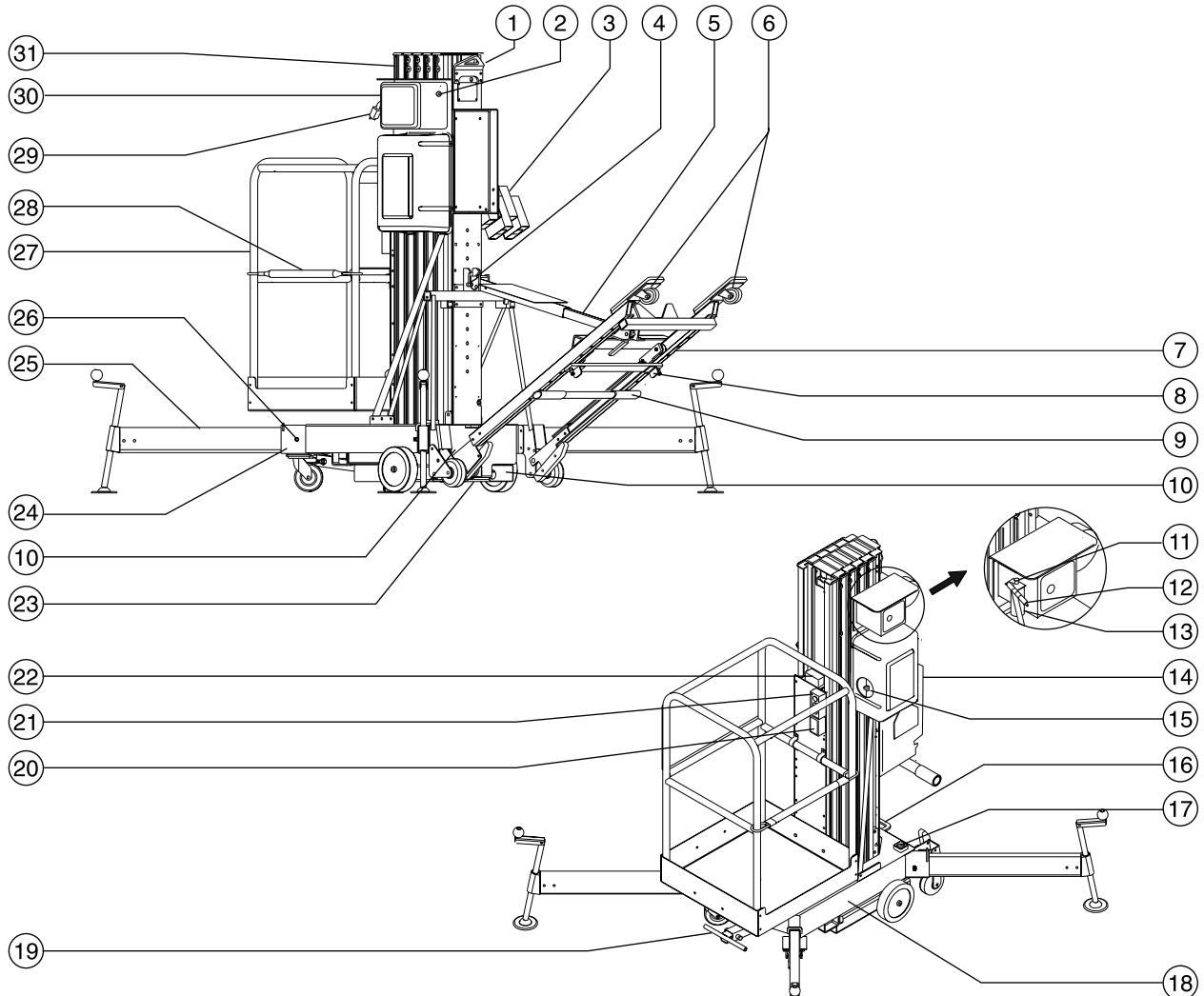

- | | | |
|---|--|--|
| 1 Lifting eye | 9 Loading pivot bar | 25 Outrigger with leveling jack |
| 2 AC models: Circuit breaker | 10 Forklift pocket | 26 Outrigger lock pin |
| 3 Outrigger storage socket | 11 Airline lubricator adjustment knob | 27 Platform |
| 4 Tilt-back frame retaining pin in strut socket | 12 Air supply for machine | 28 Platform entry mid-rail or gate |
| 5 Tilt-back strut | 13 Airline lubricator | 29 AC models: Power supply for machine
DC models: Power to platform |
| 6 Swivel lock | 14 DC models: Battery pack with charger | 30 Ground controls |
| 7 Tilt-back frame | 15 Hydraulic power unit | 31 Mast |
| 8 Loading stop bracket | 16 Winching/tie-down point | |
| | 17 Bubble level | |
| | 18 Base | |
| | 19 Sliding T-handle | |
| | 20 AC outlet | |
| | 21 Platform controls | |
| | 22 Operator's manual storage container | |
| | 23 Manual lowering valve (under machine) | |
| | 24 Base outrigger socket | |



Pre-operation Inspection



Do Not Operate Unless:

- You learn and practice the principles of safe machine operation contained in this operator's manual.

1 Avoid hazardous situations.

2 Always perform a pre-operation inspection.

Know and understand the pre-operation inspection before going on to the next section.

3 Always perform the function tests prior to use.

4 Inspect the workplace.

5 Only use the machine as it was intended.

Breather Cap - AC & DC Models

Component damage will occur if the machine is operated without a breather cap. Check to make sure the breather cap is in place in the hydraulic reservoir.

AWP-36 & AWP-40: The first time these machines are set up for use, the pipe plug in the hydraulic reservoir should be removed and permanently replaced with a breather cap.

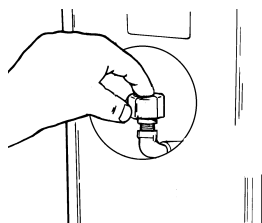

A breather cap is supplied and can be found in an envelope taped to the mast near the platform controls.

Fundamentals

It is the responsibility of the operator to perform a pre-operation inspection and routine maintenance.

The pre-operation inspection is a visual inspection performed by the operator prior to each work shift. The inspection is designed to discover if anything is apparently wrong with a machine before the operator performs the function tests.

The pre-operation inspection also serves to determine if routine maintenance procedures are required. Only routine maintenance items specified in this manual may be performed by the operator.

Refer to the list on the next page and check each of the items.

If damage or any unauthorized variation from factory delivered condition is discovered, the machine must be tagged and removed from service.

Repairs to the machine may only be made by a qualified service technician, according to the manufacturer's specifications. After repairs are completed, the operator must perform a pre-operation inspection again before going on to the function tests.

Scheduled maintenance inspections shall be performed by qualified service technicians, according to the manufacturer's specifications and the requirements listed in the responsibilities manual.

PRE-OPERATION INSPECTION

Pre-operation Inspection

- Be sure that the operator's, safety and responsibilities manuals are complete, legible and in the storage container located on the platform.
- Be sure that all decals are legible and in place. See Decals section.
- Check for battery fluid leaks and proper fluid level. Add distilled water if needed. See Maintenance section.
- AC & DC models: Check for hydraulic oil leaks and proper oil level. Add oil if needed. See Maintenance section.
- RT base models: Check for proper tire pressure. Add air to tires if needed. See Maintenance section.
- Air models: Check the oil level of the airline lubricator. See Maintenance section.
- Air models: Check the oil lubricator canister drip rate. Adjust as needed. See Maintenance section.
- Air models: Check the air filter/regulator canister. Drain water as needed. See Maintenance section.

Check the following components or areas for damage, improperly installed or missing parts and unauthorized modifications:

- Electrical components, wiring and electrical cables
- AC & DC models: Hydraulic power unit, hoses, fittings and cylinder
- Air models: Air power unit, air lines, fittings and cylinder
- Platform entry mid-rail or gate

- Sequencing cables and pulleys
- Lifting chains and idler wheels
- Nuts, bolts and other fasteners
- Mast columns and counterweight
- Breather cap
- Outriggers, leveling jacks and footpads
- Adjustable glide pads

Check entire machine for:

- Dents or damage
- Corrosion or oxidation
- Cracks in welds or structural components
- Inspect and clean battery terminals and all battery cable connections.
- Be sure that all structural and other critical components are present and all associated fasteners and pins are in place and properly tightened.

Maintenance



Observe and Obey:

- ☑ Only routine maintenance items specified in this manual shall be performed by the operator.
- ☑ Scheduled maintenance inspections shall be completed by qualified service technicians, according to the manufacturer's specifications and the requirements specified in the responsibilities manual.

Maintenance Symbols Legend

NOTICE

The following symbols have been used in this manual to help communicate the intent of the instructions. When one or more of the symbols appear at the beginning of a maintenance procedure, it conveys the meaning below.



Indicates that tools will be required to perform this procedure.



Indicates that new parts will be required to perform this procedure.

Check the Battery - DC Models



Proper battery condition is essential to good machine performance and safe operation. Improper fluid levels or damaged cables and connections can result in component damage and hazardous conditions.

⚠ WARNING

Electrocution hazard. Contact with hot or live circuits could result in death or serious injury. Remove all rings, watches and other jewelry.

⚠ WARNING

Bodily injury hazard. Batteries contain acid. Avoid spilling or contacting battery acid. Neutralize battery acid spills with baking soda and water.

NOTICE

Perform this test after fully charging the battery.

- 1 Put on protective clothing and eye wear.
- 2 Remove the battery vent caps.
- 3 Check the battery acid level. If needed, replenish with distilled water to the bottom of the battery fill tube. Do not overfill.
- 4 Install the vent caps.

MAINTENANCE

Check the Hydraulic Oil Level



Maintaining the hydraulic oil at the proper level is essential to machine operation. Improper hydraulic oil levels can damage hydraulic components. Daily checks allow the inspector to identify changes in oil level that might indicate the presence of hydraulic system problems.

- 1 Be sure the platform is fully lowered.
 - 2 Check the sight gauge on the side of the hydraulic reservoir.
- ⦿ Result: The hydraulic oil level should be visible in the middle of the sight gauge. Do not overfill.

Hydraulic oil specifications

Hydraulic oil type	Chevron Rykon Premium MV equivalent
--------------------	--

Check the Tire Pressure - RT Base Models



It is essential to maintain proper pressure in all air-filled tires. Improperly inflated tires can affect machine handling.

- 1 Check each tire with an air pressure gauge. Add air as needed. The proper air pressure is stamped on the tire.

Check the Air Line Lubricator Oil Level - Air Models



Maintaining the proper oil level in the lubricator canister is essential to safe operation and good machine performance. Failure to keep the lubricator canister at the proper oil level could result in unsafe operating conditions and possible component damage.

- 1 Be sure the platform is fully lowered.
 - 2 Inspect the lubricator canister for the proper oil level.
- ⦿ Result: The oil level must be within $\frac{1}{2}$ inch / 12.7 mm from the top of the lubricator canister.
- 3 To add oil, remove the oil lubricator canister from the lubricator base and fill with oil. Install the canister back onto the lubricator base.

Oil Specifications

Oil Type	10W automotive engine oil
----------	---------------------------

MAINTENANCE

Check the Oil Lubricator Canister Drip Rate - Air Models



Maintaining the proper oil drip rate into the lubricator canister is essential to safe operation and good machine performance. Failure to maintain the proper drip rate could result in machine component damage.

- 1 While raising the platform, visually inspect the oil lubricator sight gauge.
- ⦿ Result: There should be a maximum of 1 to 2 drops of oil visible in the sight gauge.
- 2 To adjust the drip rate, turn the oil flow control valve clockwise to decrease the flow or counterclockwise to increase the flow.
- 3 Repeat this procedure until the proper oil drip rate is achieved.

Check the Air Filter/Regulator Canister - Air Models



It is essential to drain the air filter/regulator canister of water to ensure good air motor performance and service life. A water-filled canister could cause the air motor to perform poorly and continued use could cause component damage.

- 1 Check the air filter/regulator canister for any water accumulation.
- 2 If water is visible, loosen the drain plug at the bottom of the canister and allow the water to drain out.
- 3 Tighten the drain plug.

Scheduled Maintenance

Maintenance performed quarterly, annually and every two years must be completed by a person trained and qualified to perform maintenance on this machine according to the procedures found in the service manual for this machine.

Machines that have been out of service for more than three months must receive the quarterly inspection before they are put back into service.

Function Tests



Do Not Operate Unless:

- You** learn and practice the principles of safe machine operation contained in this operator's manual.
 - 1 Avoid hazardous situations.
 - 2 Always perform a pre-operation inspection.
 - 3 Always perform the function tests prior to use.**
- Know and understand the function tests before going on to the next section.**
 - 4 Inspect the workplace.
 - 5 Only use the machine as it was intended.

Fundamentals

The function tests are designed to discover any malfunctions before the machine is put into service. The operator must follow the step-by-step instructions to test all machine functions.

A malfunctioning machine must never be used. If malfunctions are discovered, the machine must be tagged and removed from service. Repairs to the machine may only be made by a qualified service technician, according to the manufacturer's specifications.

After repairs are completed, the operator must perform a pre-operation inspection and function tests before putting the machine into service.

FUNCTION TESTS

Function Tests

Setup

- 1 Position the machine on a firm surface directly below the desired work area.
- 2 Connect to the appropriate power source:
DC models: Connect the battery pack.
AC models: Connect to a grounded 15A AC power supply. Use a 12 gauge / 3.3mm² 3-wire grounded extension cord no longer than 50 feet / 13 m.
Air models: Connect the air line.
- 3 Insert the key and turn to platform control.
- 4 Pull out the red Emergency Stop button to the on position at the ground controls.
- 5 Twist to release the red Emergency Stop button at the platform controls.
- ⦿ Result: AC & DC models: The power light should come on.
Air models: The air pressure gauge should read 80-110 psi / 5.5 - 7.8 bar.

- 6 Select an outrigger and slide it into a base socket until the outrigger lock pin snaps into place. Adjust the outrigger to level the machine and raise the base casters slightly off the ground. Level the machine using only the outriggers.

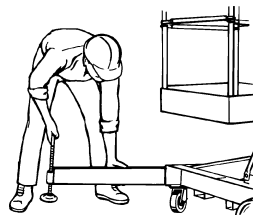

- 7 Check the interlock display lights at the ground controls. Confirm that the corresponding light is on.

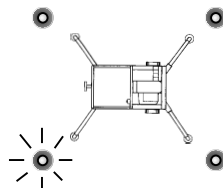

- 8 Repeat this procedure for each of the remaining outriggers.
- 9 Use the bubble level and adjust the leveling jacks until the machine base is level.

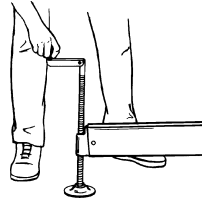

Test Emergency Stop

- 10 Push in the red Emergency Stop button at the ground controls to the off position.
- 11 Push in the control activate button and rotate the up/down switch in the direction of intended travel.
- ⦿ Result: The up/down function should not operate.

FUNCTION TESTS

- 12 Push in the red Emergency Stop button at the platform controls to the off position.
 - 13 Pull out the red Emergency Stop button at the ground controls to the on position.
 - 14 Push in the control activate button and rotate the up/down switch in the direction of intended travel.
- ⊙ Result: The up/down function should not operate.

Test Outrigger Interlock

- 15 Twist to release the red Emergency Stop button at the platform controls.
- ⊙ Result: The up/down functions should operate.
- 16 Unscrew one leveling jack until the corresponding interlock display light turns off.
- ⊙ Result: The up/down function should not operate.
- 17 Return the leveling jack to the previous setting and check the bubble level.
 - 18 Repeat this procedure for each outrigger.

**Test Auxiliary Platform Lowering
- AC & DC Models**

- 19 Raise the platform slightly.
 - 20 Disconnect the power source from the machine.
 - 21 Turn the key switch to ground control.
 - 22 Push in the auxiliary platform lowering button at the ground controls.
- ⊙ Result: The platform should lower.

- 23 Connect the power source to the machine.
 - 24 Turn the key switch to platform control.
 - 25 Raise the platform slightly.
 - 26 Disconnect the power source from the machine.
 - 27 Push in the control activate button and rotate the up/down switch in the down direction.
- ⊙ Result: The platform should lower.
- 28 Connect the power source to the machine.

Test Manual Lowering

- 29 Raise the platform slightly.
- 30 Activate the manual lowering valve located at the bottom of the hydraulic cylinder.

- ⊙ Result: The platform should lower.

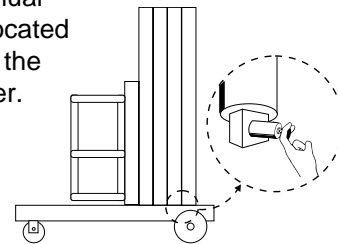

Workplace Inspection



Do Not Operate Unless:

You learn and practice the principles of safe machine operation contained in this operator's manual.

- 1 Avoid hazardous situations.
- 2 Always perform a pre-operation inspection.
- 3 Always perform function tests prior to use.

4 Inspect the workplace.

Know and understand the work place inspection before going on to the next section.

- 5 Only use the machine as it was intended.

Workplace Inspection

Be aware of and avoid the following hazardous situations:

- drop-offs or holes
- bumps, floor obstructions or debris
- slopes that exceed the machine's leveling capability
- unstable or slippery surfaces
- overhead obstructions and high voltage conductors
- hazardous locations
- inadequate surface support to withstand all load forces imposed by the machine
- wind and weather conditions
- the presence of unauthorized personnel
- other possible unsafe conditions

Fundamentals

The workplace inspection helps the operator determine if the workplace is suitable for safe machine operation. It should be performed by the operator prior to moving the machine to the workplace.

It is the operator's responsibility to read and remember the workplace hazards, then watch for and avoid them while moving, setting up and operating the machine.

Operating Instructions



Do Not Operate Unless:

- You learn and practice the principles of safe machine operation contained in this operator's manual.
 - 1 Avoid hazardous situations.
 - 2 Always perform a pre-operation inspection.
 - 3 Always perform function tests prior to use.
 - 4 Inspect the workplace.
 - 5 Only use the machine as it was intended.**

Fundamentals

The Operating Instructions section provides instructions for each aspect of machine operation. It is the operator's responsibility to follow all the safety rules and instructions in the operator's, safety and responsibilities manuals.

Using the machine for anything other than lifting personnel, along with their tools and materials, to an aerial work site is unsafe and dangerous.

If more than one operator is expected to use a machine at different times in the same work shift, each operator is expected to follow all safety rules and instructions in the operator's manual. That means every new operator should perform a pre-operation inspection, function tests and a work place inspection before using the machine.

Setup

- 1 Position the machine on a firm surface directly below the desired work area.
- 2 Connect to the appropriate power source:
DC models: Connect the battery pack.
AC models: Connect to a grounded 15A AC power supply. Use a 12 gauge / 3.3mm² 3-wire grounded extension cord no longer than 50 feet / 13 m.
Air models: Connect the air line.
- 3 Insert the key and turn to platform control.
- 4 Pull out the red Emergency Stop button at the ground controls and twist to release the red Emergency Stop at the platform controls. Be sure the power light is on or the air pressure gauge reads 80-110 psi / 5.5 - 7.8 bar.
- 5 Install the outriggers and adjust to level the machine and raise the base casters slightly off the ground.

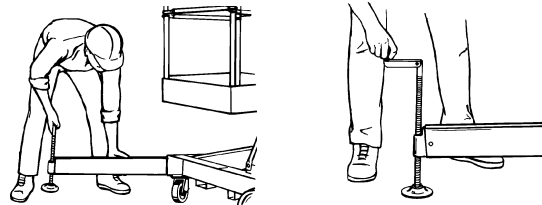

- 6 Be sure all four interlock display lights at the ground controls are on and all four outriggers are in firm contact with the ground.
- 7 Use the bubble level to make sure the machine is level.



Note: If adjustment is necessary, check the bubble level and interlock display again to make sure the machine is level and all four interlock display lights are on.

OPERATING INSTRUCTIONS

Emergency Stop

Push in the red Emergency Stop button at the platform controls or at the ground controls to stop the up function.

Platform Raise and Lower

- 1 Pull out the red Emergency Stop button to the on position at the ground controls. Twist to release the red Emergency Stop button at the platform controls.
- 2 Push in the control activate button and rotate the up/down switch in the desired direction of travel.

Manual Lowering

- 1 Activate the manual lowering valve located at the bottom of the hydraulic cylinder.

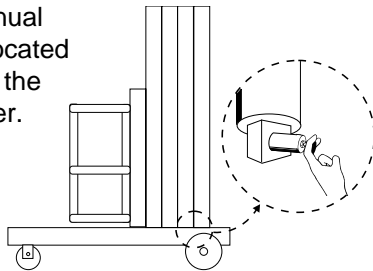
**Auxiliary Platform Lowering
- AC & DC Models**

- 1 Turn the key switch to ground control. Pull out the red Emergency Stop button to the on position.
- 2 Activate the auxiliary platform lowering button at the ground controls.

Fall Protection

Personal fall protection equipment (PFPE) is not required when operating this machine. If PFPE is required by job site or employer rules, the following shall apply:

All PFPE must comply with applicable governmental regulations and must be inspected and used in accordance with the manufacturer's instructions.

After Each Use

- 1 Select a safe storage location—firm, level surface, weather protected, clear of obstruction and traffic.
- 2 Chock the wheels to prevent the machine from rolling.
- 3 Remove the key to secure from unauthorized use.
- 4 DC models: Recharge the battery.

Battery Charging Instructions



Battery and Charger Instructions

Observe and Obey:

- Do not use an external charger or booster battery.
- Charge the battery in a well-ventilated area.
- Use proper AC input voltage for charging as indicated on the charger.
- Use only Genie authorized battery and charger.

To Charge Battery

- 1 Open the battery pack lid to access the battery.
- 2 Remove the battery vent caps and check the battery acid level. If necessary, add only enough distilled water to cover the plates. Do not overfill prior to the charge cycle.
- 3 Replace the battery vent caps.
- 4 Be sure that the DC output cord is properly connected to the battery.
Black to negative, red to positive.
- 5 Connect the battery charger to a grounded AC circuit.
- 6 The charger will turn off automatically when the battery is fully charged.
- 7 Check the battery acid level when the charge cycle is complete. Replenish with distilled water to the bottom of the fill tube. Do not overfill.

Dry Battery Filling and Charging Instructions

- 1 Remove the battery vent caps and permanently remove the plastic seal from the battery vent openings.
- 2 Fill each cell with battery acid (electrolyte) until the level is sufficient to cover the plates.

Do not fill to maximum level until the battery charge cycle is complete. Overfilling can cause the battery acid to overflow during charging. Neutralize battery acid spills with baking soda and water.

- 3 Install the battery vent caps.
- 4 Charge the battery.
- 5 Check the battery acid level when the charging cycle is complete. Replenish with distilled water to the bottom of the fill tube. Do not overfill.

Transport Instructions



Transport Instructions

Observe and Obey:

- Be sure the transport vehicle capacity and loading surfaces are sufficient to support the machine weight. See the serial label for the machine weight. Some pick-up truck tailgates are not strong enough to support the weight of the machine and may require reinforcement.
- Do not load the machine onto a transport vehicle unless it is parked on a level surface.
- The transport vehicle must be secured to prevent rolling while the machine is being loaded.
- The machine must be securely fastened to the transport vehicle. Use chains or straps of ample load capacity.
- Be sure to lock both swivel casters on the tilt-back frame.
- Do not transport with the machine resting on the tilt-back frame.

Lifting Instructions

The number of people required to load and unload a machine is dependent on a number of factors, including but not limited to:

- the physical condition, strength and disabilities or prior injuries of the people involved
- the vertical and horizontal distances the machine has to be moved
- the number of times the machine will be loaded or unloaded
- the stance, posture and grip used by the people involved
- the lifting techniques used
- the site conditions and weather in which the activity is being performed (i.e., slippery, icy, raining)

The appropriate number of people and proper lifting techniques must be used to prevent physical injury.

TRANSPORT INSTRUCTIONS

Loading for Transport

- 1 Fully lower the platform.
- 2 Push in the red Emergency Stop buttons, turn the key switch to the off position and remove the key.
- 3 Remove the outriggers from the base and place them in the storage sockets.
- 4 DC models: Disconnect the battery cable and remove the battery pack.
- 5 Inspect the entire machine for loose or unsecured items.
- 6 Slide the stop bracket to the top lock position.

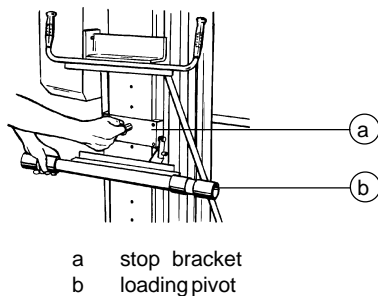

All models without tilt-back frame

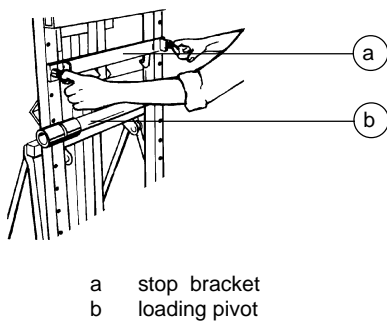

All models with tilt-back frame

- 7 Hook the loading pivot to the stop bracket.

- 8 Position the machine flush against the loading surface. Lower and lock the stop bracket to the lowest lock pin position above the loading surface.

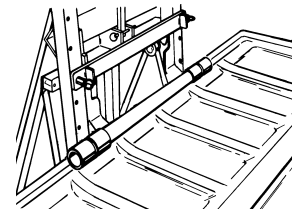

- 9 All models with tilt-back frame:
Be sure both stop bracket lock pins are fully locked.
Be sure both tilt-back frame swivel casters are locked.
- 10 Slide out the T-handle until the lock pin snaps into place.

- 11 Lift the T-handle to tilt the machine onto the loading surface. Use the appropriate number of people and proper lifting techniques.

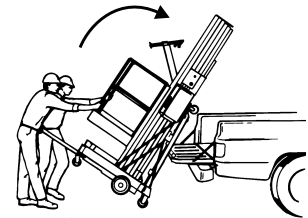

- 12 Carefully push the machine into the transport position.

- 13 Return the sliding T-handle to the stowed position.

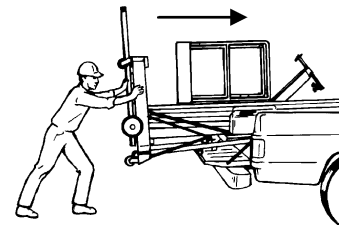

- 14 Secure the machine base and mast to the transport vehicle. See Securing the Machine on the next page.

- 15 Reverse this procedure to unload the machine.

TRANSPORT INSTRUCTIONS

Securing the Machine

Use chains or straps of ample load capacity.

Use a minimum of 2 chains.

Adjust the rigging to prevent damage to the chains.

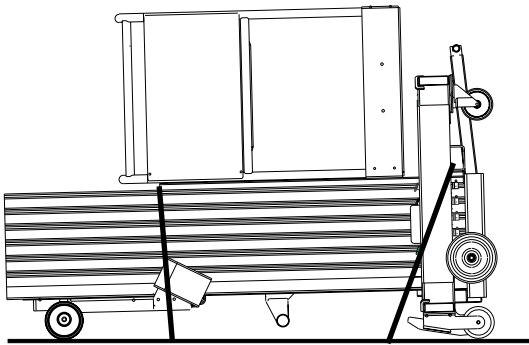
**Winching the Machine onto a Flatbed Truck**

- 1 Fully lower the platform.
- 2 Push in the red Emergency Stop buttons, turn the key switch to the off position and remove the key.
- 3 Remove the outriggers from the base and place them in the storage sockets.
- 4 Inspect the entire machine for loose or unsecured items.
- 5 Connect the cable to the winching point located at the rear of the base.
- 6 Carefully winch the machine onto the truck.
- 7 Secure the machine base to the transport vehicle. See Securing the Machine.

Loading the Machine With a Crane

Use the lifting eye mounted on the rear mast column.

The battery pack must be removed before lifting the machine with a crane. Disconnect the battery plug before removing the battery pack.

Be sure to inspect the machine and remove any loose or unsecured items.

Always place the lifting hook through the lifting eye so that it points away from the machine.

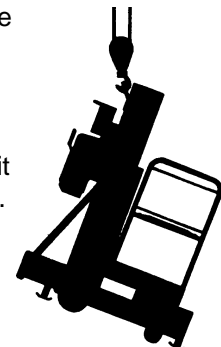
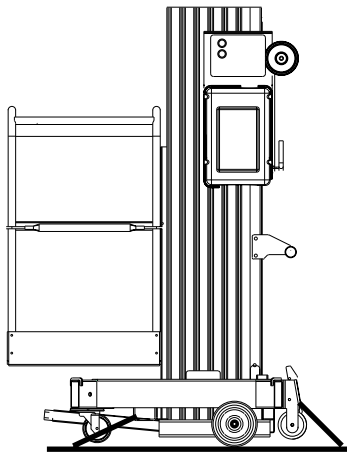

Tilt-back Operation Instructions



Tilt-back Operation Instructions

Observe and obey:

- The retaining pin must be inserted to prevent the spring-loaded tilt-back frame from dropping.
- Do not tilt the machine back unless the area is clear of personnel and obstructions.
- Do not stand behind or under the tilt-back frame when raising or lowering it.

Tilt-back Frame

The Genie AWP Super Series has a tilt-back frame which allows the machine to roll through a standard doorway. The tilt-back frame is standard equipment on standard base AWP-36S and 40S models, and optional on standard base AWP-15S, 20S, 25S and 30S models. The tilt-back frame is not available on narrow base machines or rough terrain base machines.

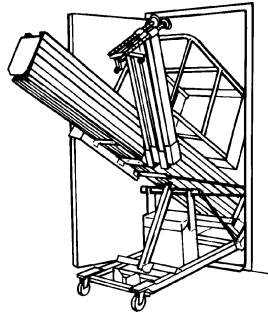

Lifting Instructions

The number of people required to load and unload a machine is dependent on a number of factors, including but not limited to:

- the physical condition, strength and disabilities or prior injuries of the people involved
- the vertical and horizontal distances the machine has to be moved
- the number of times the machine will be loaded or unloaded
- the stance, posture and grip used by the people involved
- the lifting techniques used
- the site conditions and weather in which the activity is being performed (i.e., slippery, icy, raining)

The appropriate number of people and proper lifting techniques must be used to prevent physical injury.

TILTBACK OPERATION INSTRUCTIONS

Lowering the Tilt-back Assembly

- 1 Be sure the area behind the machine and under the tilt-back frame is clear of personnel and obstructions.
- 2 Fully lower the platform.
- 3 Remove the outriggers from the base and place them in the storage sockets.

The tilt-back frame is spring loaded and will immediately fall outward when the retaining pin is removed. Maintain a firm grasp on the tilt-back frame and remove the retaining pin.

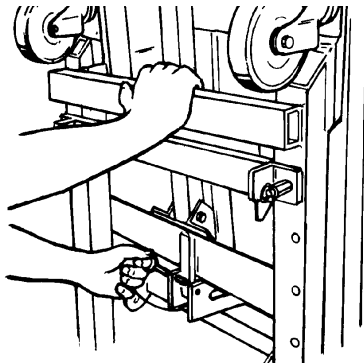

- 4 Lower the tilt-back frame and guide the tilt-back strut into the strut socket.

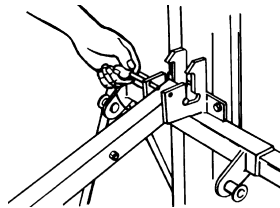
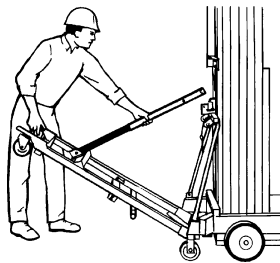

- 5 Insert the retaining pin into the strut socket.

Tilting Back the Machine

- 1 Slide out the T-handle until the lock pin snaps into place.
- 2 Lift the machine with the T-handle to mid-tilt position—casters on the tilt-back frame are in contact with the floor, and the machine is supported by the extended tilt-back strut. Use the appropriate number of people and proper lifting techniques.

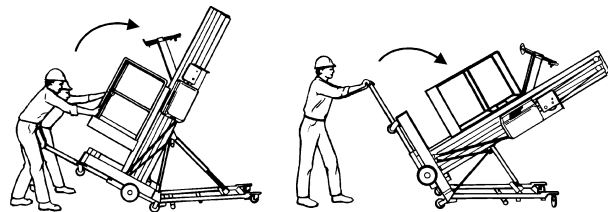
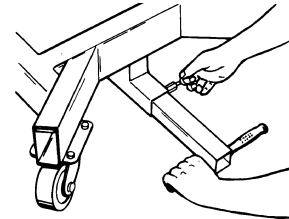

- 3 Continue lifting until the telescoping tilt-back strut is completely compressed.
- 4 Return the sliding T-handle to the stowed position.

TILTBACK OPERATION INSTRUCTIONS

Returning the Machine to Standing Position

- 1 Be sure the area below the machine base and T-handle is clear of personnel and obstructions.
- 2 Slide out the T-handle until the lock pin snaps into place.
- 3 Carefully pull down the T-handle until the machine rests at mid-tilt position.
- 4 Lower the machine with the T-handle until the base casters are in contact with the ground. Use the appropriate number of people and proper lifting techniques.
- 5 Return the sliding T-handle to the stowed position.

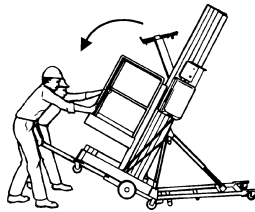

Stowing the Tilt-back Assembly

- 1 Remove the retaining pin.

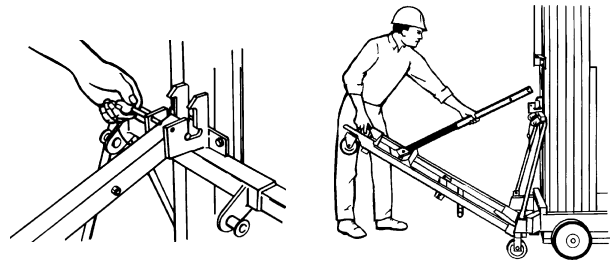

- 2 Firmly grasp the tilt-back frame and remove the tilt-back strut from the strut socket.
- 3 Lift the tilt-back frame, hold in an upright position against the spring and secure with the retaining pin.

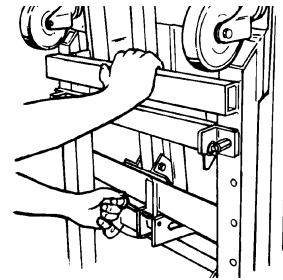

Decals

Inspection for Decals with Words

Determine whether the decals on your machine have words or symbols. Use the appropriate inspection to verify that all decals are legible and in place.

Part No.	Description	Quantity
27838	Warning - Tilt-back Hazards/Instructions	1
27839	Label - Sliding T-handle	1
27840	Label - Retaining Pin	1
27841	Label - Stop Bracket	1
27842	Label - Loading Pivot	1
27843	Label - Tilt-back Strut	1
27844	Label - Strut Socket	1
27857	Caution - Pipe Plug	1
27863	Warning - Collision Hazard	3
27864	Notice - Lower Stop Bracket Before . . .	1
27865	Label - Bubble Level	1
27867	Label - Swivel Lock	1
27868	Danger - Relief Valve	1
27872	Danger - Tip-over Hazard, Outriggers	1
27873	Notice - Maintain Firm Grasp	1
27874	Label - Insert Retaining Pin	1
28174	Label - Power to Platform, 230V	2
28235	Label - Power to Platform, 115V	2
28372	Caution - Quick Disconnect	1
31070	Danger - Tip-over Hazard, Moving	1
31071	Warning - Failure to Read	1
31245	Warning - Collision Hazard	1
37141	Notice - Manual Lowering Instructions	1
37142	Notice - Operating Instructions	1
37143	Notice - Max Capacity 350 lbs / 136 kg AWP-20S, 25S, 30S, 36S	1
37144	Notice - Max Capacity 300 lbs / 159 kg AWP-40S	1

Part No.	Description	Quantity
37145	Label - Manual Lowering Valve	1
38122	Label - Manual Storage Container	1
38142	Label - Circuit Breaker, AC models	1
41266	Label - Interlock Display, Air Models, Standard Base	1
41268	Label - Interlock Display, Air Models, Narrow Base and Rough Terrain Base	1
52996	Cosmetic - Genie Logo	1
52999	Cosmetic - AWP-20S	2
62992	Cosmetic - AWP-25S	2
62993	Cosmetic - AWP-30S	2
62994	Cosmetic - AWP-36S	2
62995	Cosmetic - AWP-40S	2
72086	Label - Lifting Eye	1
82366	Label - Chevron Rykon	1
82780	Label - Interlock Display	1
82781	Label - Interlock Display	1
82802	Label - Function Enable	1
82907	Danger - Battery Charger Safety	1
82975	Danger - Collision Hazard	1
82986	Danger - Electrocutation Hazard	1
97522	Label - Wheel Load	4
97523	Label - Outrigger Load	4
114008	Notice - Max Side Force 50 lbs / 222 N, ANSI/CSA	1
114009	Notice - Max Manual Force 45 lbs / 200N, AUS	1
114011	Danger - General Safety	1

DECALS

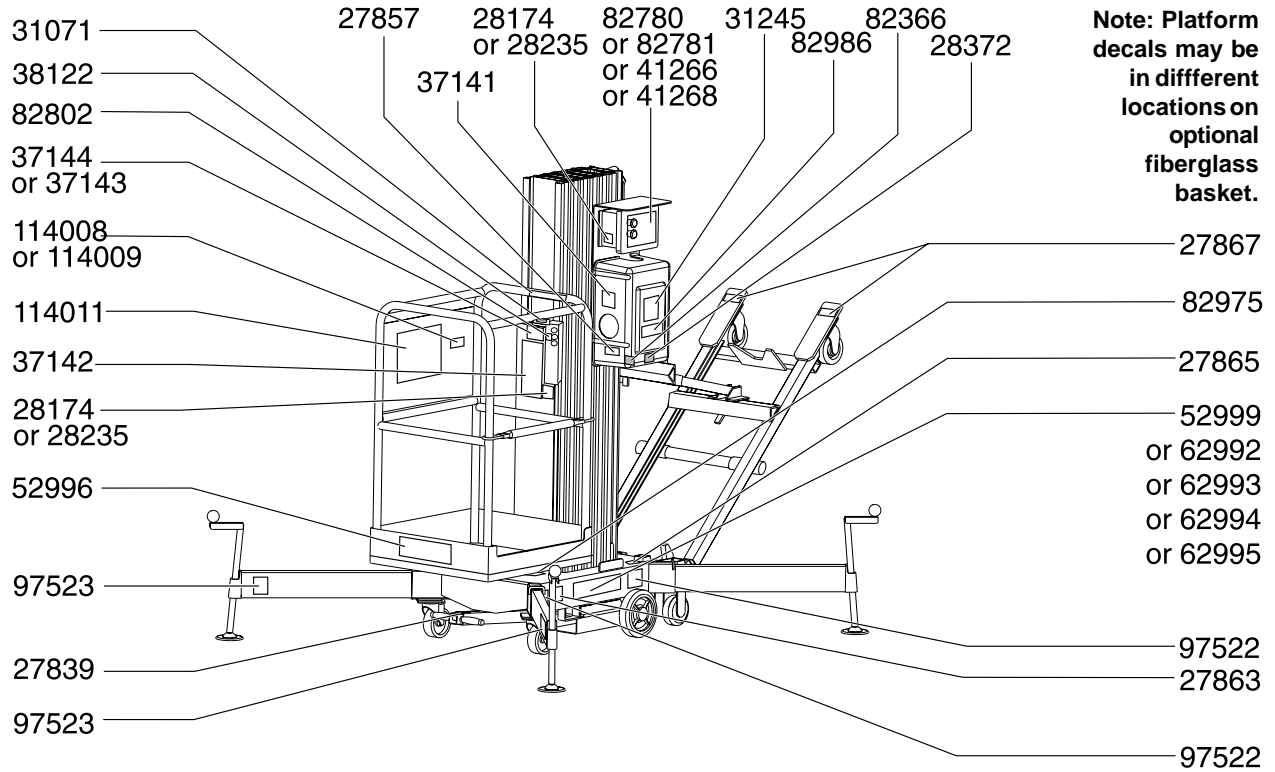

Models with Tilt-back Frame

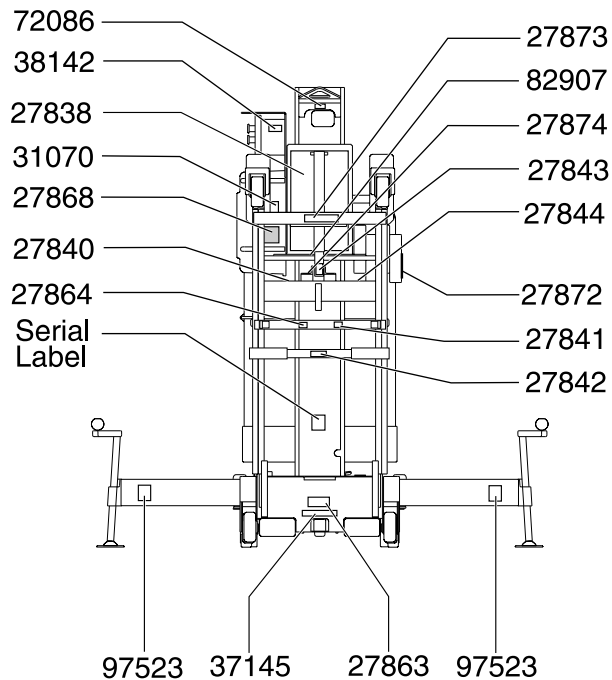

Models without Tilt-back Frame

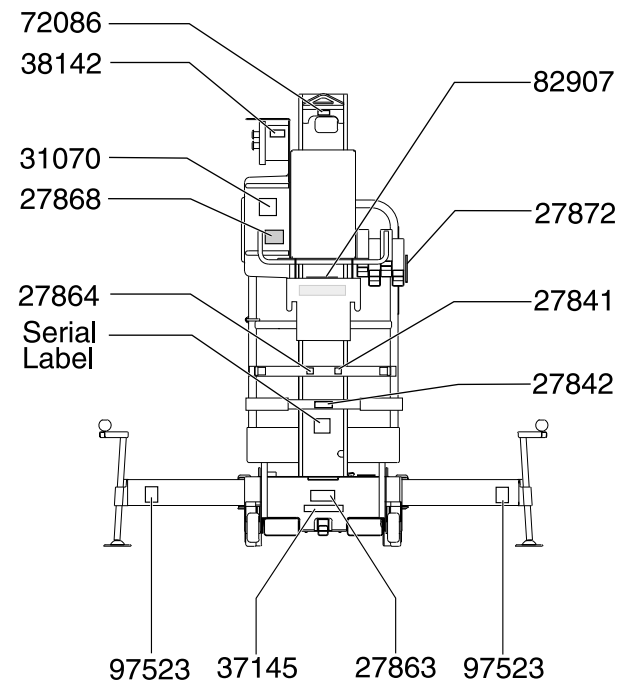

DECALS

Inspection for Decals with Symbols

Determine whether the decals on your machine have words or symbols. Use the appropriate inspection to verify that all decals are legible and in place.

Part No.	Description	Quantity
28174	Label - Power to Platform, 230V	2
28235	Label - Power to Platform, 115V	2
52996	Cosmetic - Genie Logo	1
52999	Cosmetic - AWP-20S	2
62992	Cosmetic - AWP-25S	2
62993	Cosmetic - AWP-30S	2
62994	Cosmetic - AWP-36S	2
62995	Cosmetic - AWP-40S	2
82481	Danger - Battery Charger Safety	1
82487	Label - Read the Manual	1
82614	Caution - Collision Hazard	1
82780	Label - Interlock Display	1
82781	Label - Interlock Display	1
82802	Label - Function Enable	1
82913	Danger - Max Capacity, 159 kg AWP-20S, 25S, 30S, 36S	1
82914	Danger - Max Capacity, 136 kg AWP-40S	1
82915	Label - Manual Lowering Valve	1
82916	Danger - Maximum Manual Force 200N, CE	1

Part No.	Description	Quantity
82973	Warning - Insert Pin	1
82974	Warning - Collision Hazard	1
82976	Danger - Wind Speed, 51 cm Outrigger	4
82977	Danger - Wind Speed, 66 cm Outrigger	4
82978	Danger - Wind Speed, 77 cm Outrigger	4
82979	Danger - Wind Speed, 91 cm Outrigger	4
82980	Danger - Wind Speed, 1.02 m Outrigger	4
82981	Danger - Wind Speed, 1.17 m Outrigger	4
82982	Danger - Wind Speed, 1.52 m Outrigger	4
82983	Danger - Wind Speed, 1.91 m Outrigger	4
82984	Danger - Wind Speed, 2.16 m Outrigger	4
82987	Danger - Electrocution Hazard	1
82988	Label - Read the Manual, Tilt-back Frame	1
97522	Label - Wheel Load	4
97523	Label - Outrigger Load	4
97815	Label - Lower Mid-rail	1
114010	Danger - Maximum Side Force 222N, ANSI	1

DECALS

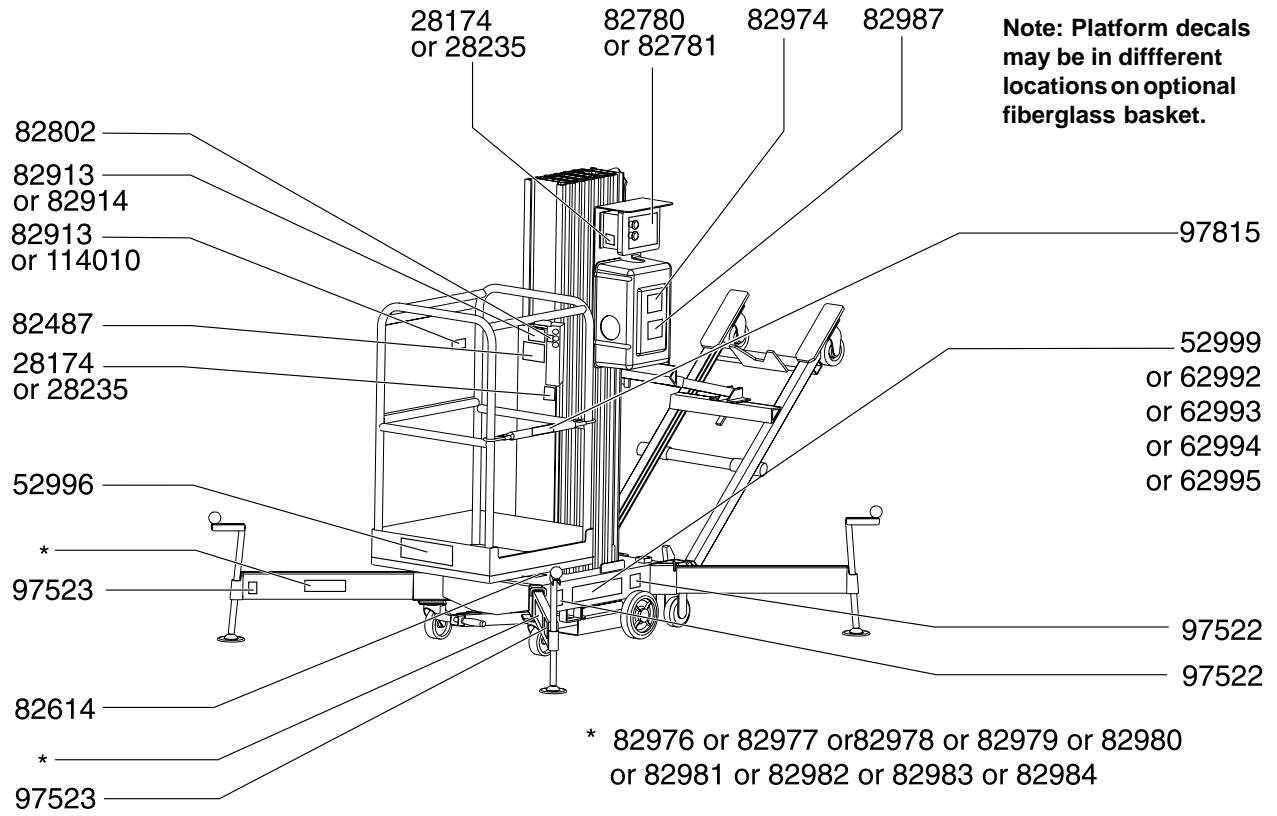

Models with Tilt-back Frame

Models without Tilt-back Frame

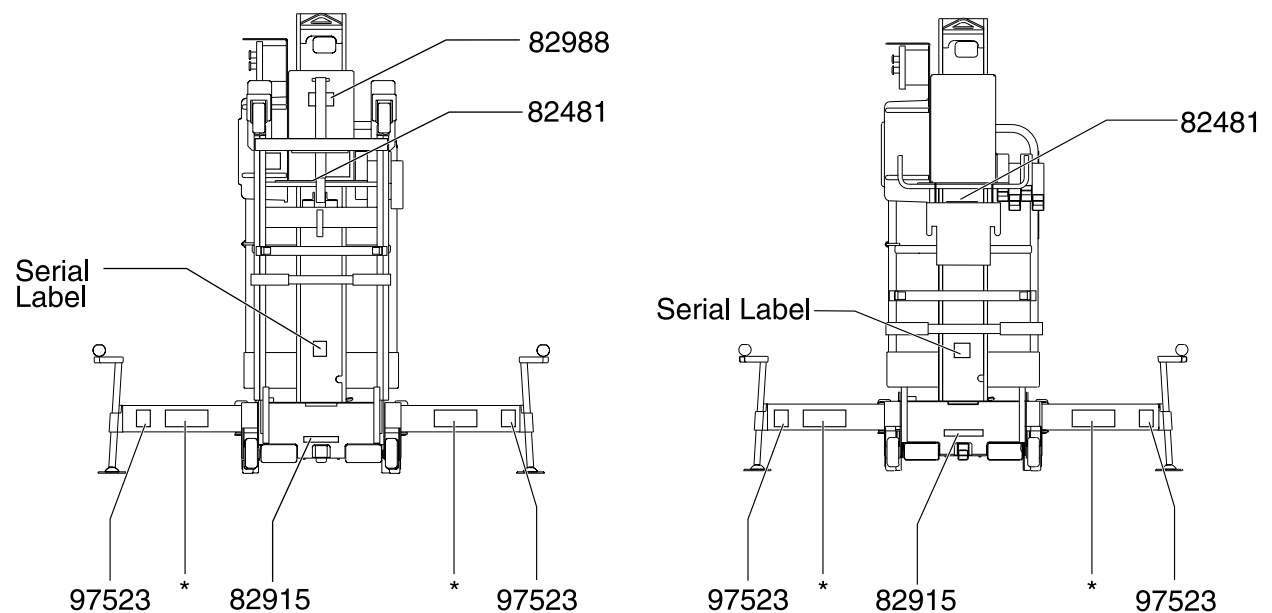

Specifications

Machine Specifications

Height, working maximum	
AWP-20S	26 ft 1 in / 8.0 m
AWP-25S	30 ft 9 in / 9.4 m
AWP-30S	35 ft 6 in / 10.8 m
AWP-36S	42 ft 5 in / 12.9 m
AWP-40S	46 ft 3 in / 4.1 m
Height, platform maximum	
AWP-20S	20 ft 1 in / 6.1 m
AWP-25S	24 ft 9 in / 7.6 m
AWP-30S	29 ft 6 in / 9.0 m
AWP-36S	36 ft 6 in / 11.1 m
AWP-40S	40 ft 3 in / 12.3 m
Height, stowed	
AWP-20S, 25S, 30S	78 in / 2.0 m
AWP-36S, 40S	109 ¹ / ₂ in / 2.8 m
Width	
Standard base	29 in / 73.6 m
Narrow base	22 in / 55.8 cm
Rough terrain base	29 ¹ / ₂ in / 75 cm
Length, AWP-20S, 25S, 30S	
Standard base	46 in / 1.2 m
Narrow base	29 ¹ / ₂ in / 75 cm
Rough terrain base	58 in / 1.5 m
Length, AWP-36S, 40S	
Standard base	55 in / 1.4 m
Weight	See Serial Label
Wheel load, maximum	509 lbs / 231 kg
Outrigger load, maximum	400 lbs / 181 kg

Lift capacity	
AWP-20S, 25S, 30S, 36S	350 lbs / 159 kg
AWP-40S	300 lbs / 136 kg
Power source	
DC model	12V
AC model	110V or 220V
Air motor	100 psi / 6.9 bar @ 80 cfm / 37760 cc/sec
Ambient operating temperature	-20°F to 135°F -29°C to 57°C

Airborne noise emissions	80 dB
Maximum sound level at normal operating workstations (A-weighted)	

Platform dimensions (length x width x height)

Standard platform	27 x 26 x 44 ³ / ₄ in
gated or sliding mid-rail	69 cm x 66 cm x 1.1 m
Gated ultra-narrow platform	22 x 18 x 44 ³ / ₄ in
	56 cm x 46 cm x 1.1 m
Gated narrow platform	26 x 20 x 44 ³ / ₄ in
	66 cm x 51 cm x 1.1 m
Standard fiberglass platform	29 x 26 ¹ / ₂ x 43 ¹ / ₂ in
	74 cm x 67 cm x 1.1 m
Narrow fiberglass platform	26 x 22 x 43 ¹ / ₂ in
	66 cm x 56 cm x 1.1 m
Front entry gated narrow platform	20 x 26 x 44 ³ / ₄ in
	51 cm x 66 cm x 1.1 m
Extra large front and side entry platform	30 x 28 x 44 ³ / ₄ in
	76 cm x 71 cm x 1.1 m

Outrigger Specifications

Standard Base	AWP-20S	AWP-25S	AWP-30S
Outrigger footprint (l x w) ANSI / CSA	60 ³ / ₄ x 52 ³ / ₄ in 1.5 x 1.3 m	60 ³ / ₄ x 52 ³ / ₄ in 1.5 x 1.3 m	69 ¹ / ₄ x 61 ¹ / ₄ in 1.8 x 1.6 m
Outrigger footprint (l x w) CE / AUS Indoor	60 ³ / ₄ x 52 ³ / ₄ in 1.5 x 1.3 m	69 ¹ / ₄ x 61 ¹ / ₄ in 1.8 x 1.6 m	75 ¹ / ₂ x 67 ¹ / ₂ in 1.9 x 1.7 m
Outrigger footprint (l x w) CE / AUS Outdoor	83 ¹ / ₄ x 75 ¹ / ₄ in 2.1 x 1.9 m	89 x 81 in 2.3 x 2.1 m	117 ¹ / ₄ x 109 ¹ / ₂ in 3.0 x 2.8 m
Corner access/wall access* ANSI / CSA	14 ¹ / ₂ / 5 ¹ / ₂ in 36.9 / 7.4 cm	14 / 3 in 35.1 / 7.4 cm	18 ¹ / ₂ / 4 ³ / ₄ in 46.6 / 11.9 cm
Corner access/wall access* CE / AUS Indoor	14 ¹ / ₂ / 5 ¹ / ₂ in 36.9 / 7.4 cm	19 ¹ / ₄ / 7 ¹ / ₄ in 48.6 / 18.2 cm	22 ¹ / ₄ / 8 in 56.5 / 20.3 cm
Corner access/wall access* CE / AUS Outdoor	30 / 16 ³ / ₄ in 76 / 42.4 cm	32 ¹ / ₂ / 17 in 82.5 / 43.4 cm	50 ³ / ₄ / 28 ³ / ₄ in 1.3 m / 73 cm

* Corner of platform top rail to corner of wall with ability to rotate leveling jack.



SPECIFICATIONS

Outrigger Specifications Standard Base	AWP-36S	AWP-40S
Outrigger footprint (l x w) ANSI / CSA	83 ¹ / ₄ x 75 ¹ / ₄ in 2.1 x 1.9 m	89 x 81 in 2.3 x 2.0 m
Outrigger footprint (l x w) CE / AUS Indoor	83 ¹ / ₄ x 75 ¹ / ₄ in 2.1 x 1.9 m	89 x 81 in 2.3 x 2.0 m
Outrigger footprint (l x w) CE / AUS Outdoor	139 x 131 in 3.5 x 3.3 m	153 x 145 in 3.9 x 3.7 m
Corner access/wall access* ANSI / CSA	28 ¹ / ₂ / 14 ¹ / ₄ in 72.7 / 36.2 cm	31 ¹ / ₄ / 14 ¹ / ₂ in 79.4 / 37.1 cm
Corner access/wall access* CE / AUS Indoor	28 ¹ / ₂ / 14 ¹ / ₄ in 72.7 / 36.2 cm	31 ¹ / ₄ / 14 ¹ / ₂ in 79.4 / 37.1 cm
Corner access/wall access* CE / AUS Outdoor	52 / 31 ¹ / ₄ in 1.3 m / 79.3 cm	50 ³ / ₄ / 28 ³ / ₄ in 1.3 m / 73 cm

* Corner of platform top rail to corner of wall with ability to rotate leveling jack.

Outrigger Specifications Narrow Base / Rough Terrain Base	AWP-20S	AWP-25S	AWP-30S
Outrigger footprint (l x w) ANSI / CSA	64 x 48 ¹ / ₄ in 1.6 x 1.2 m	64 x 48 ¹ / ₄ in 1.6 x 1.2 m	71 ¹ / ₂ x 58 in 1.8 x 1.5 m
Outrigger footprint (l x w) CE / AUS Indoor	71 ¹ / ₄ x 58 in 1.8 x 1.5 m	71 ¹ / ₄ x 58 in 1.8 x 1.5 m	74 ¹ / ₂ x 65 ¹ / ₂ in 1.9 x 1.6 m
Outrigger footprint (l x w) CE / AUS Outdoor	83 ¹ / ₄ x 74 in 2.1 x 1.9 m	95 ¹ / ₄ x 89 ³ / ₄ in 2.4 x 2.2 m	112 x 112 in 2.8 x 2.8 m
Corner access/wall access* ANSI / ANSI	14 ¹ / ₄ / 8 ¹ / ₂ in 36.2 / 21.6 cm	13 / 6 in 33 / 15.2 cm	18 ¹ / ₂ / 7 ¹ / ₄ in 47 / 18.4 cm
Corner access/wall access* CE / AUS Indoor	21 / 12 ¹ / ₄ in 53.3 / 31.1 cm	19 ¹ / ₂ / 9 ³ / ₄ in 49.5 / 24.7cm	22 / 9 in 55.8 / 22.8 cm
Corner access/wall access*	76.2 / 44.4 cm	98.4 / 53.3 cm	1.3 m / 67.3 cm

* Corner of platform top rail to corner of wall with ability to rotate leveling jack.

Continuous improvement of our products is a Genie policy. Product specifications are subject to change without notice or obligation.



Genie Scandinavia Phone +46 31 575100 Fax +46 31 579020
Genie France Phone +33 (0)2 37 26 09 99 Fax +33 (0)2 37 26 09 98
Genie Iberica Phone +34 93 579 5042 Fax +34 93 579 5059
Genie Germany Phone +49 (0)4202 88520 Fax +49 (0)4202 8852-20
Genie U.K. Phone +44 (0)1476 584333 Fax +44 (0)1476 584334
Genie Mexico City Phone +52 55 5666 5242 Fax +52 55 5666 3241

Genie North America
 Phone 425.881.1800
 Toll Free USA and Canada
 800.536.1800
 Fax 425.883.3475

Genie Australia Pty Ltd.
 Phone +61 7 3375 1660
 Fax +61 7 3375 1002

Genie China
 Phone +86 21 53852570
 Fax +86 21 53852569

Genie Malaysia
 Phone +65 98 480 775
 Fax +65 67 533 544

Genie Japan
 Phone +81 3 3453 6082
 Fax +81 3 3453 6083

Genie Korea
 Phone +82 25 587 267
 Fax +82 25 583 910

Genie Brasil
 Phone +55 11 41 665 755
 Fax +55 11 41 665 754

Genie Holland
 Phone +31 183 581 102
 Fax +31 183 581 566

Distributed By: