

OWNER'S MANUAL

For Model: GP100SIL

GP100BLK

GP100BLU

GEORGE FOREMAN™

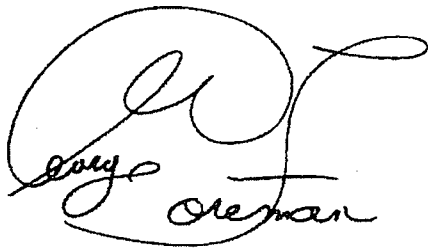

Portable Propane Grill

salton.

FOR YOUR SAFETY

If you smell gas:

- 1. Shut off gas to the appliance.**
- 2. Extinguish any open flame.**
- 3. Open Lid.**
- 4. If odor continues, immediately call your gas supplier or your fire department.**

FOR YOUR SAFETY

- 1. Do not store or use gasoline or other flammable vapors and liquids in the vicinity of this or any other appliance.**
- 2. An LP cylinder not connected for use shall not be stored in the vicinity of this or any other appliance.**

WARNING

- 1. Do not store spare LP cylinder within 10 feet (3 m) of this appliance.**
- 2. Do not store or use gasoline or other flammable liquids or vapors within 25 feet (8 m) of this appliance.**

IMPORTANT SAFEGUARDS

READ AND SAVE THESE INSTRUCTIONS

WARNING: A risk of fire or explosion exists in all propane grills. Read this manual before use. Failure to follow all instructions may result in serious personal injury, property damage, or death.

When using propane grills, basic safety precautions should always be followed to reduce the risk of fire and injury to persons, including the following:

1. Read all instructions before using the grill.
2. Do not touch hot surfaces. Use handles or knobs and oven mitts or pot holders.
3. Keep children and pets away from the grill at all times.
4. This grill is not for use by children.
5. Do not leave this grill unattended while in use.
6. Do not move the grill when in use. Allow to cool before moving, putting on or taking off parts, and before cleaning and storing the grill.
7. To disconnect, turn Temperature Control Knob to LOCK/OFF.
8. Do not operate any grill after the grill malfunctions, or has been dropped or damaged in any manner. Contact Consumer Service for return authorization, examination, repair or adjustment.
9. The use of accessory attachments not recommended by the grill manufacturer may cause injuries.
10. This grill is for outdoor use only. NEVER operate grill in enclosed areas, as this could lead to gas accumulating from a leak, causing an explosion or a carbon monoxide buildup which could result in injury or death. DO NOT USE in garages, sheds or any enclosed areas.
11. Do not use grill for other than intended use.
12. Extreme caution must be used when moving a grill containing hot oil or other hot liquids. Allow liquid to cool before removing and emptying Drip Tray. Do not remove Grill from Base until Grill is cool.
13. Do not attempt to dislodge food or clean the grill when it is hot.
14. Fuel, such as charcoal briquettes, is not to be used with this grill.

SAVE THESE INSTRUCTIONS

**THIS GRILL IS NOT FOR COMMERCIAL USE.
FOR OUTDOOR USE ONLY.**

Additional Important Safeguards

1. **CAUTION: This grill generates heat and escaping steam during use. Proper precautions must be taken to prevent the risk of burns, fires or other damage to persons or property. Use of protective oven mitts or gloves is recommended.**
2. All users of this grill must read and understand this Owner's Manual before operating or cleaning this grill.
3. When using this grill, provide adequate air space above and on all sides for air circulation. Do not allow this grill to touch clothing, dish towels or other flammable materials during use.
4. **IMPORTANT:** Minimum clearance of 16 inches around all sides of the grill should always be maintained and the appliance shall not be located under overhead unprotected combustible construction.
5. If this grill begins to malfunction during use, immediately turn the Temperature Control Knob to LOCK/OFF. Do not use or attempt to repair the malfunctioning grill.
6. This outdoor cooking gas grill is not intended for use in or on recreational vehicles and/or boats.
7. The use of alcohol, prescription or non-prescription drugs may impair the consumer's ability to properly assemble or safely operate the grill.
8. When cooking with oil/grease, fire extinguishing materials shall be readily accessible. In the event of an oil/grease fire do not attempt to extinguish with water. Use Type BC dry chemical fire extinguisher or smother fire with dirt, sand or baking soda.
9. In the event of rain while cooking with oil/grease, turn off the grill burner and gas supply, and immediately cover the Grill Plate. Do not attempt to move the grill or Grill Plate.
10. When cooking, the grill must be on a level and stable surface in an area clear of combustible materials. An asphalt surface (blacktop) may not be acceptable for this purpose.
11. Make sure the grill is in the LOCK/OFF position when placing the Grill Plate into position.
12. The grill is not intended for and should never be used as a heater.
13. Keep grill area clear and free from combustible materials, gasoline and other flammable vapors and liquids.
14. Do not obstruct the flow of combustion and ventilation air.
15. Always remove lid before lighting your grill.
16. Do not attempt to disconnect the regulator or any gas fitting while the unit is in operation.
17. Do not wear clothing with loose flowing sleeves while lighting or using the grill.
18. Use barbecue tools with long, heat-resistant handles.
19. The grill should never face directly into the wind.
20. Do not operate Grill in a high-traffic area.
21. After use, allow Grill to cool completely before cleaning.
22. We recommend storing Grill indoors or, if unable to store indoors, always cover Grill with protective cover. Always keep out of the reach of children.

Special Instructions for the Use of Regulator and LP (Propane) Cylinders

- The propane grill is equipped with a regulator having a CGA No. 600 cylinder connection device which is for connecting to a one pound PROPANE cylinder ONLY. See Illustration.
- Grill installation must conform with local codes, or in the absence of local codes, with the National Fuel Gas Code, ANSI Z223.1, Storage and Handling of Liquefied Petroleum Gases, ANSI/NFPA 58 or CSA B149.1, Natural Gas and Propane Installation Code.
- Use grill only with LP (propane) gas. Use grill only with the regulator/valve assembly supplied.
- Never use charcoal briquettes or lighter fluid in a gas grill.
- Discard used and empty fuel cylinder in a safe place.
- Store spare fuel canisters in a well-ventilated area away from the grill.
- Do not puncture or burn fuel canister.
- Do not operate the grill if there is a gas leak present.
- Do not enlarge orifice or burner ports when cleaning the regulator and burner.
- If you smell gas, turn Temperature Control Knob to LOCK/OFF to shut off gas to the grill. Extinguish any open flame and open Lid. If odor continues, immediately call your gas supplier or your fire department.
- Do not store or use gasoline or other flammable vapors and liquids in the vicinity of this or any other grill.
- An LP cylinder not connected for use shall not be stored in the vicinity of this or any other appliance.
- The LP-gas supply cylinder to be used must be constructed and marked in accordance with the specifications for LP-gas cylinders of the U.S. Department of Transportation (DOT) CFR 49 or the National Standard of Canada, CAN/CSA-B339, Cylinders, Spheres and Tubes for the Transportation of Dangerous Goods.
- If the grill is not in use, the Temperature Control Knob must be turned to LOCK/OFF to shut off the gas cylinder. Storage of a grill indoors is permissible only if the cylinder is disconnected and removed from the grill. Cylinders must be stored outdoors out of the reach of children and must not be stored in a building, garage or any other enclosed area.
- The regulator may make a humming or whistling noise during operation. This will not affect safety or use of grill.
- Save cylinder cap and reinstall when not in use.
- Cylinder supply system must be arranged for vapor withdrawal. The gas cylinder must be upright in use. Do not block the pressure relief valve during use or storage.
- Always remove one pound cylinder from grill when transporting and when not in use.

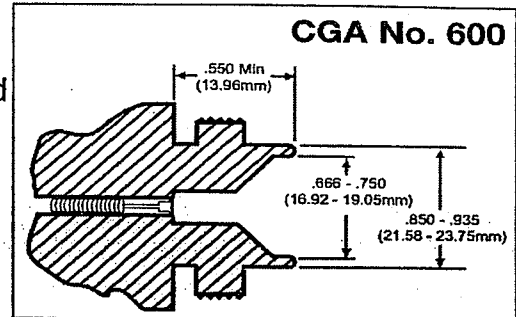

Getting To Know Your GP100* Propane Grill

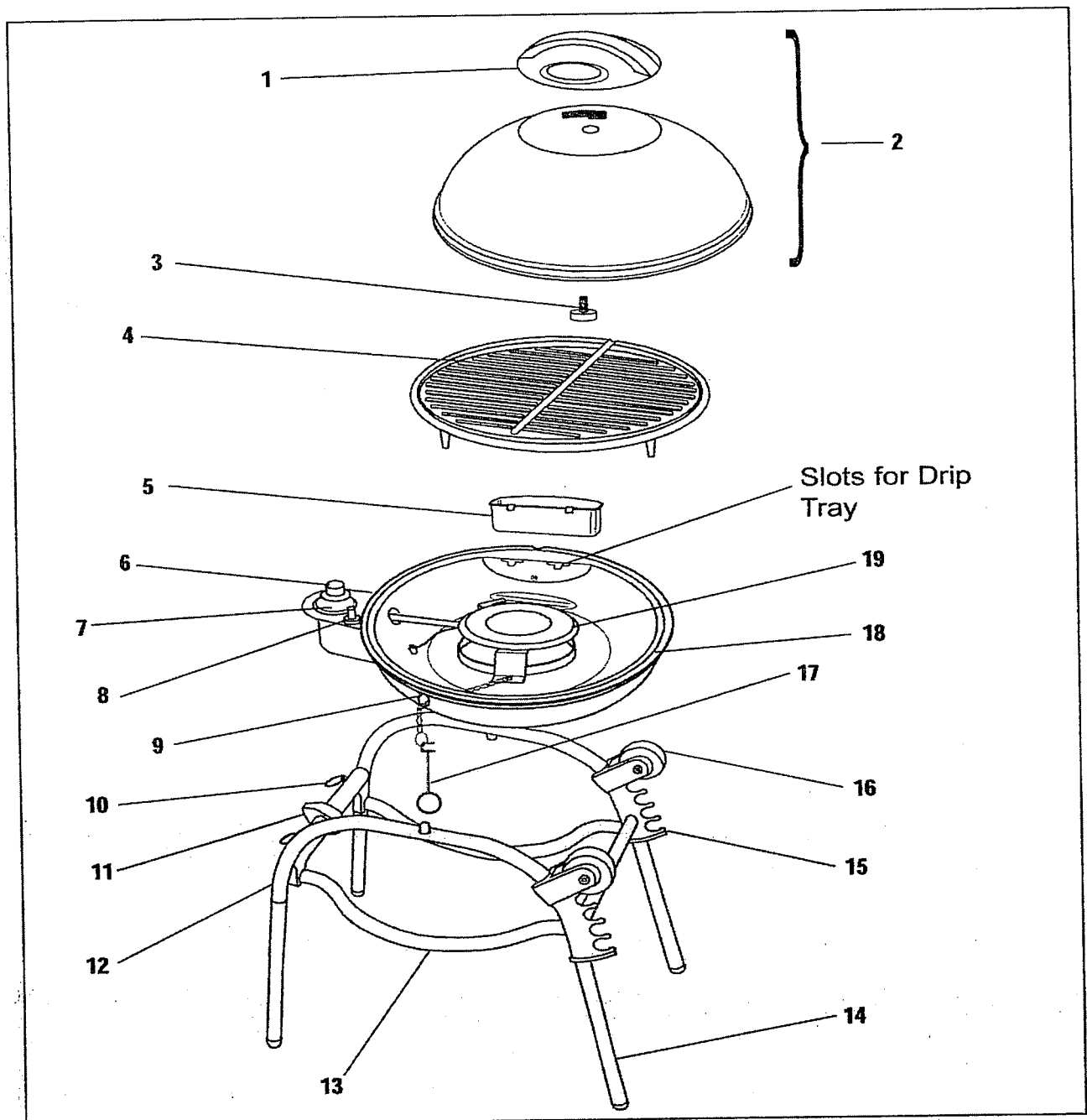

- | | |
|---|--|
| 1. Lid Handle/Vent (P/N 21659) | 12. Base Frame (P/N 21650) |
| 2. Lid Assembly (P/N 21660SIL/BLK/BLU)* | 13. Transport Handle (P/N 21651) |
| 3. Screw/Washer (P/N 21661) | 14. Pedestal Legs (4) (P/N 21652 each) |
| 4. Grill Plate (P/N 21645) | 15. Leg Storage Rack (2) (P/N 21653) |
| 5. Drip Tray (P/N 21646) | 16. Transport Wheels (2) (P/N 21654) |
| 6. Temperature Control Knob (P/N 21647) | 17. Match Holder (P/N 21656) |
| 7. Regulator (P/N 21663) | 18. Grill Base |
| 8. Ignitor Assembly (P/N 21648) | 19. Burner Assembly |
| 9. Flame Viewing Hole | |
| 10. Lock Pin (2) (P/N 21657 each) | |
| 11. Transport Lock (P/N 21649) | |
- * Add suffix "SIL" for silver, "BLK" for black or "BLU" for blue Lid color.

Before First Use

1. Remove the Grill and any packaging materials.
2. Place the Base Frame on a flat, level surface.
3. Slide the Transport Lock to the right and raise the Transport Handle from the storage position.
4. Remove the Grill Plate, Grill Base, Lid and Drip Tray. Wipe the Grill Base and Lid with a damp cloth to remove any dust. Wash the Grill Plate and Drip Tray in warm, soapy water. Rinse and dry thoroughly.

5. The Handle/Vent and mounting hardware, (Screw/Washer) are shipped in an inverted fashion, requiring minor assembly. Remove the Handle/Vent from the inside of the Lid by unscrewing the Screw/Washer. Remove all parts, then properly position the Handle/Vent on the top of the Lid. Make sure the Handle/Vent stop pin enters the Vent slot in the Lid. From the inside of the Lid, place the Screw/Washer through the hole in the Lid and Handle/Vent. Securely fasten with a Phillips head screw driver. See Figure 1.

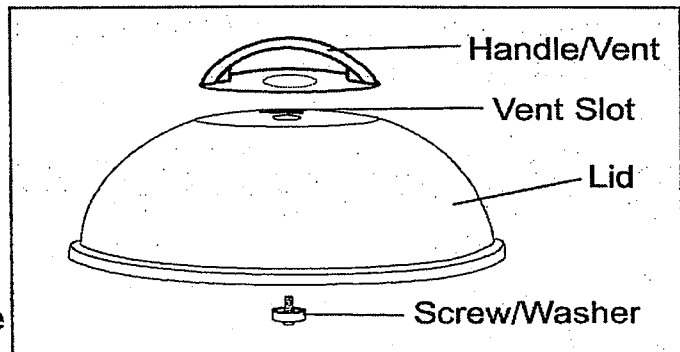

Figure 1

6. Slide the Drip Tray into the slots in the Grill Base.
7. See "Grilling Positions" on the following pages and place the Grill Base on the Base Frame. Refer to Figure 2 and hook the Slotted Bracket around the Locator Peg under the Base Frame. Align the hole in the Grill Base with the Locator Peg on the opposite side of the Base Frame.
8. Place the Grill Plate on the Grill Base and place the Lid over the Grill Plate.

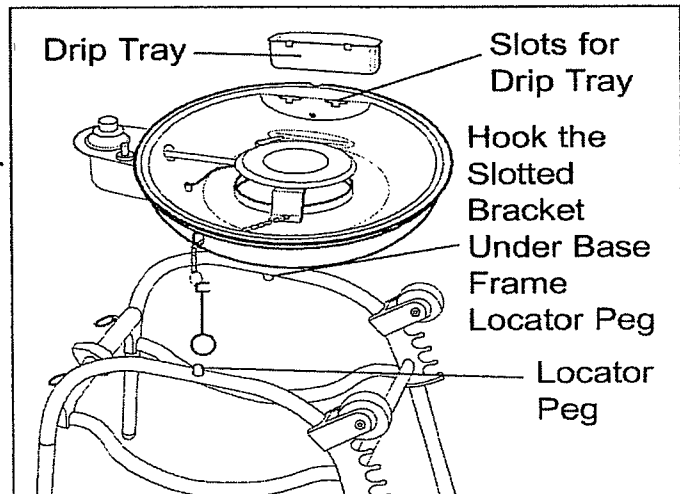

Figure 2

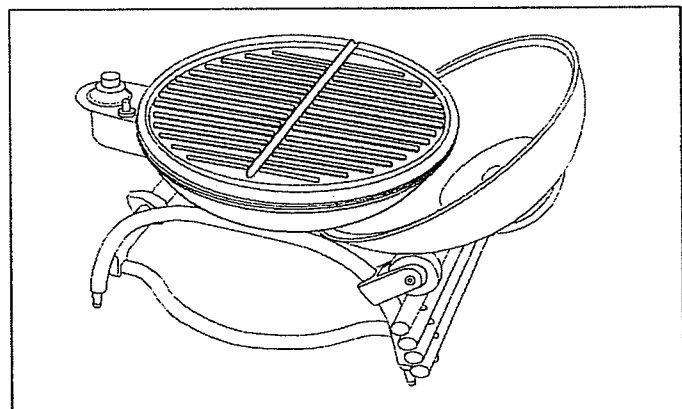

Figure 3

NOTE: If the Lid is to be removed temporarily it may be placed between the Grill and the Wheels as shown in Figure 3.

Grill Positions

The Wheel-It and Grill-It™ Portable Propane Grill is compact enough to transport to any grilling location. Wheel-It from the storage shed to the patio, to a picnic in the park, or off on a camping trip. The Portable Propane Grill easily transforms from storage to transport and to high or low Grill-It positions.

Storage Position: This position makes the Grill compact enough for space saving storage. The Legs are stored in the Leg Storage Rack and the Transport Handle folds over the top of the Lid and snaps into place to secure all parts.

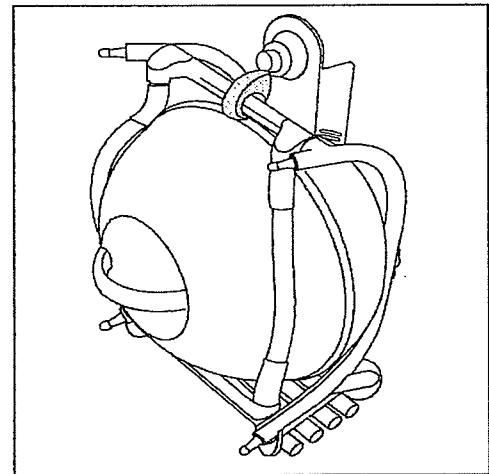

Figure 4

Transport Position: To transform the Grill to the transport position, raise the Transport Handle from the closed position and swing it over the Lid. Pull one of the Lock Pins from its storage location. Slide the Transport Handle sideways until the white marker line is just visible then rotate the Transport Handle to align the two arrows. Insert the Lock Pin into the front location to lock the Transport Handle. Slide the Transport Lock into the locked position and roll away.

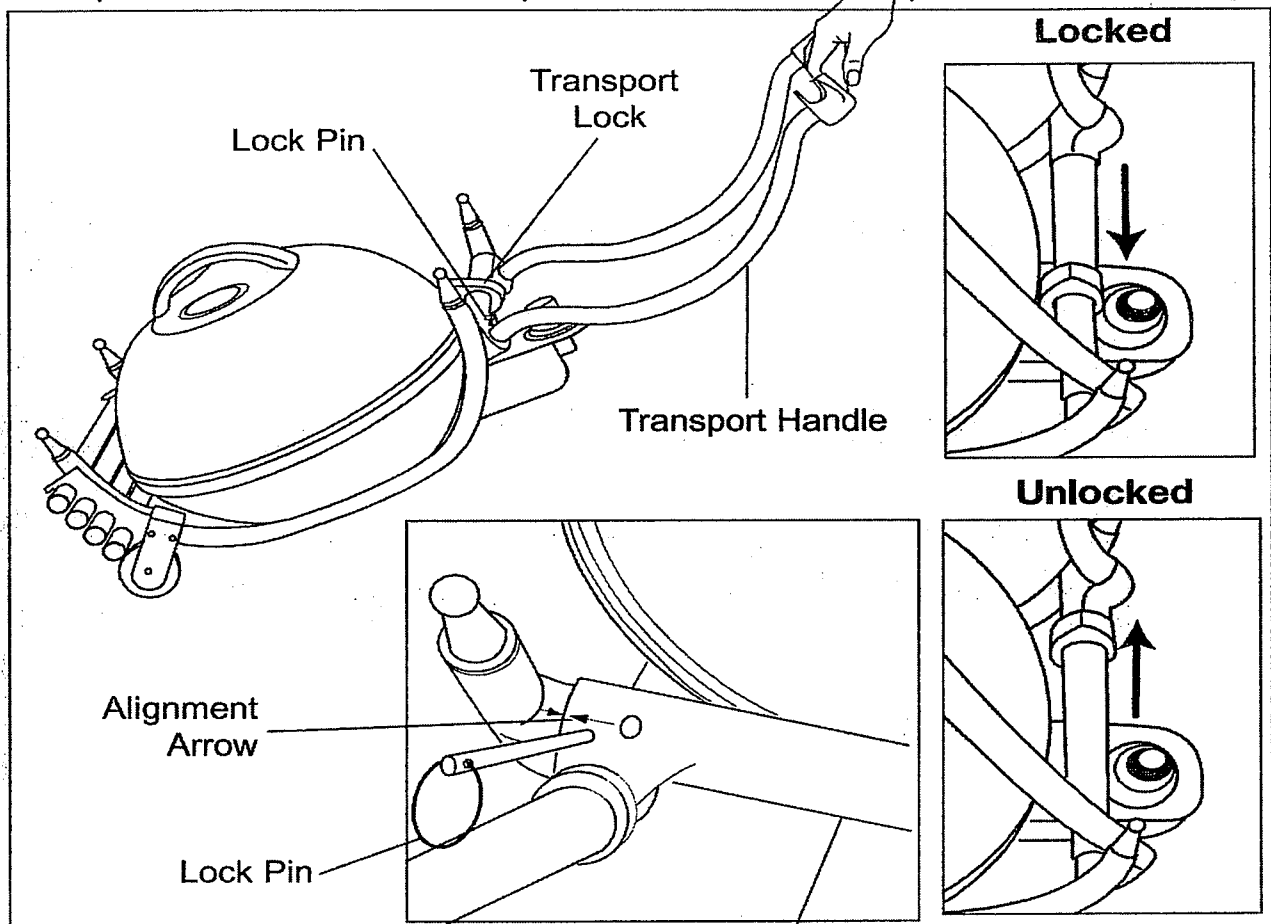

Figure 5

Grill Positions (Cont.)

Low Grilling Position: Using the Grill in this position is great for beach barbeques, camping sites, tail-gate parties or picnics in the park.

To transform the grill from the Transport Position to the Low Grilling Position, release the Transport Lock by sliding it from the middle "locked" position to the side "unlocked" position. Lift the Grill Base, Grill Plate and Lid from the Base Frame and set aside. Rotate the Transport Handle back to the closed position and 'snap' it into place. Turn the Frame over, allowing it to rest on the Leg Connectors.

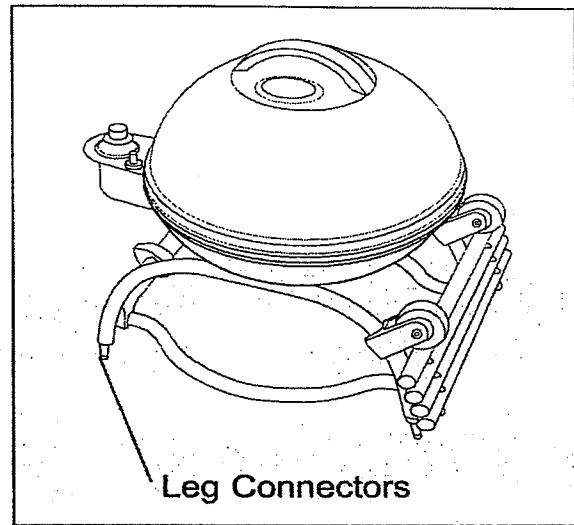

Figure 6

Place the Grill Base on the Base Frame by hooking the slotted bracket around the Locator Peg under the Base Frame. Align the hole in the Grill Base with the Locator Peg on the opposite side of the Base Frame. Place the Grill Plate on the Grill Base. **ATTACH DRIP TRAY INTO THE SLOTS.** (Refer to Figure 2 in 'Before First Use'.) Attach the Propane Cylinder. See 'Attaching Propane Gas Cylinder' for details. The Grill is ready for use.

Upright Grilling Position: This position is ideal for patio use or any time you feel more comfortable Grilling in the standing position.

To establish the Upright Grilling Position, follow the instructions for establishing the Low Grilling position, but before the Frame is turned over, remove the four Legs from the Leg Storage Rack. Firmly fit them on the Leg Connectors and stand the Frame upright. Place the Grill Base, Grill Plate and Drip Tray in position. Attach the Propane Cylinder as instructed in 'Attaching Propane Gas Cylinder'. The Grill is ready for use.

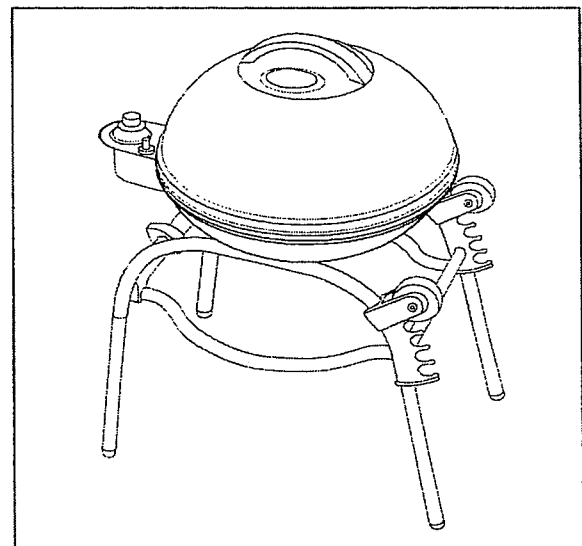

Figure 7

Make sure the Drip Tray is in proper position, and remember that the Grill should always be operated with the Regulator on the left and the Drip Tray in the rear.

Attaching Propane Gas Cylinder

Turn the Temperature Control Knob to the LOCK/OFF Position. Push the one pound propane cylinder slightly into the valve while turning counterclockwise until a snug fit is obtained.

Testing for Leaks

SAFETY PRECAUTIONS:

- Test all gas connections for leaks before using your propane grill.
- Test for leaks every time you connect the gas supply.
- Do not smoke while checking for leaks.
- **DANGER - Do not use an open flame to check for gas leaks. Be sure there are no sparks or open flames in the area while you check for leaks. This will result in a fire or explosion which can cause serious bodily injury or death, and damage to property.**
- Test for leaks outdoors in a well ventilated area.

1. Mix a couple tablespoons of liquid detergent with an equal amount of water. Use mild soap and water. **DO NOT USE HOUSEHOLD CLEANING AGENTS.**
2. Be sure that the Temperature Control Knob is in the LOCK/OFF position.
3. Use a clean paint brush to brush soapy solution onto connection between gas cylinder and Regulator orifice, and watch for bubbles.
4. If bubbles form or if a bubble grows, there is a leak. Retighten connection and repeat steps (2) and (3).

NOTE: If you cannot stop a leak, remove gas cylinder and check for damaged threads, dirt and debris at the connection and gas cylinder. Also check to see if anything is obstructing flow of gas at the connection and gas cylinder openings. Remove any obstruction that may be found and repeat leak test.

Checking the Ignitor:

- The Temperature Control Knob must be in the "LOCK/OFF" position. Press the Ignitor button rapidly. A "CLICK" should be heard and spark seen through Flame Viewing Hole.

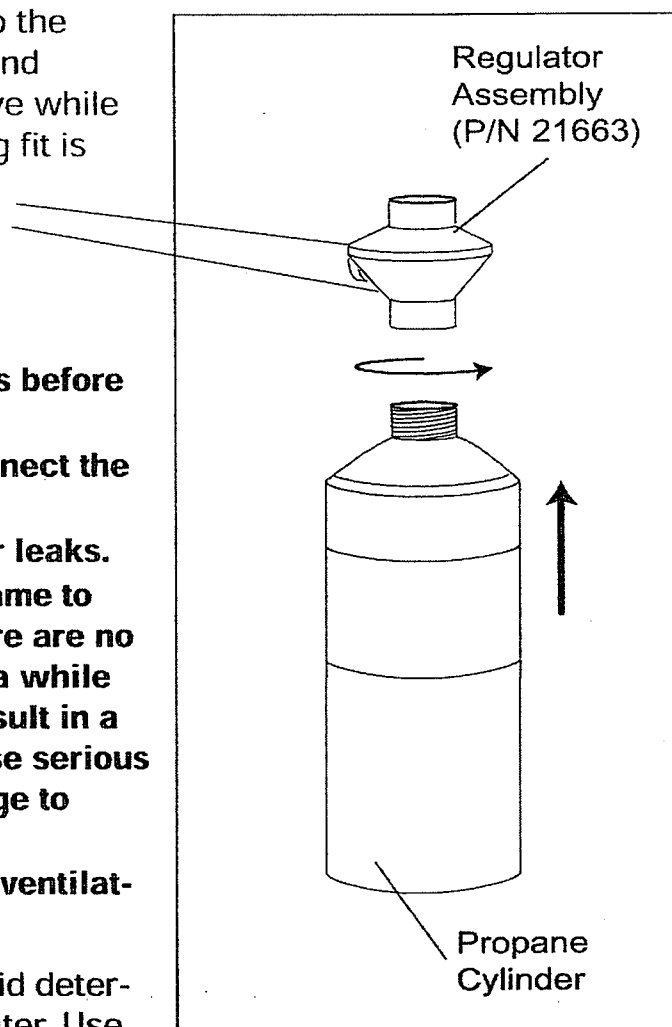

Figure 8

How To Use the George Foreman GP100 Propane Grill

IMPORTANT: Make sure the Drip Tray is in proper position before use.

Lighting Burner with Ignitor:

1. Turn Temperature Control Knob counterclockwise to "OFF", push in, and then turn the Temperature Control knob to your desired setting.
2. To light, rapidly push the Ignitor button down until it "clicks". Use Flame Viewing Hole to be sure all burner ports light and stay lit.
3. If Ignitor **does not** work, turn the Temperature Control Knob to OFF/LOCK. Remove the Lid and Grill Plate to allow the gas to dissipate. Wait five minutes, then follow match lighting instructions below.

Lighting Burner with Matches:

1. Secure a paper match to Match Holder, light the match, and place lit match through the Flame Viewing Hole to the nearest burner ports.
2. Turn Temperature Control Knob counterclockwise to "OFF", push in, and then turn the Temperature Control Knob to "HIGH".

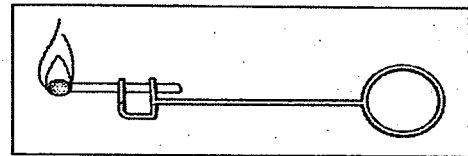

Figure 9

WARNING: If burner does not light within 5 seconds, turn Temperature Control Knob to the LOCK/OFF position. Remove the Lid and Grill Plate to allow the gas to dissipate. Wait 5 minutes, then try again.

Grilling Instructions:

1. Light burner and turn the Temperature Control Knob from HIGH to LOW. Check the flame through the Flame Viewing Hole making sure the burner is lit.
2. **To preheat:** Place the Lid over the Grill Plate and preheat on HIGH for 8 minutes. During the first use, you may notice a slight odor caused by the curing of paint and parts. **IMPORTANT:** Do not leave lid on the Grill Plate for more than 8 minutes, or without food loaded on the Grill Plate. The non-stick coating may be damaged.
3. After the 8 minute preheat period, carefully remove the Lid and place food onto the Grill Plate. Cook until done, turning at least once halfway through cooking time for most foods. Adjust flame with Temperature Control Knob as needed.
4. You can control the moisture of foods to some extent by opening or closing the Lid Vent. Turning the Lid Handle/Vent clockwise will open the vent for drier cooking. Turning the Lid Handle/Vent counter-clockwise will reduce the vent opening and retain moisture within the food.

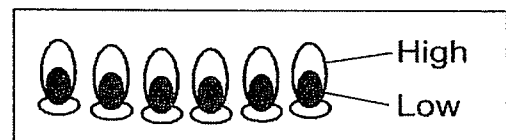

Figure 10

CAUTION: Condensation may collect on the inside of the Lid when cooking. Use caution when removing Lid.

How To Use the George Foreman GP100 Propane Grill (Cont.)

Grilling Instructions Continued:

5. When the food is cooked, remove with heat resistant plastic or wooden spatula or other utensil. Be sure to always use either plastic or wooden utensils so as not to scratch the non-stick surface. Never use metal tongs, forks or knives as these can damage the coating on the Grill Plate.

CAUTION: Do not leave any utensils on the Grill Plate surface while it is hot.

6. When finished cooking, or when the propane cylinder is empty, turn the Temperature Control Knob to the LOCK/OFF position and remove the propane cylinder.
7. Allow the Grill to cool before disassembling and cleaning.
8. When cool, the Drip Tray may be removed and emptied. **Be sure the liquid has cooled before removing Drip Tray.**

Grilling Hints and Tips

- Use tender cuts of meat for grilling.
 - Marinate tougher cuts of meat to tenderize them before grilling.
 - To avoid drying out meat and fish, turn only once and do not pierce.
 - To turn meat and fish, use a large flat plastic or wooden spatula to support the food.
 - Place meat or chicken to be roasted in a shallow baking pan. Using oven mitts carefully place pan on preheated Grill, taking care not to scratch the non-stick surface. Place Lid on the Grill Plate.
- NOTE: Just resting a baking container on top of the non-stick surface will not damage it. Do not use saucepans or plates.
- Do not cut food on non-stick surface.
 - Use only heat resistant plastic or wooden utensils on non-stick surfaces.
 - Adjust heat setting gradually and only as necessary. Cooking foods at too high a temperature can cause them to dry out.
 - When grilling fish or chicken breast fillets, tuck extremely thin parts under to prevent over cooking.

Grilling Guide

The following times are to be used as a guideline only. Preheat the Grill for eight minutes. Cooking times will vary due to the cut or thickness of the meat being cooked. To be sure that the food is done, use a meat thermometer. If the food is not quite done, continue to cook and check periodically so it is not over cooked.

Food & Quantity	Temperature Setting	Approximate Cooking Time	Special Instructions
Beef			
Hamburgers, 4 oz. each, 3/4" thick	Medium High	12-15 min.	Turn halfway through cooking time.
Hamburgers, 8 oz. each, 1" thick	Medium High	15-18 min.	Turn halfway through cooking time.
Ribeye Steak, 12 oz. each, 1/2" thick	Medium High	Med.-Rare 4-5 min. Medium 5-6 min. Well 6-7 min.	Turn halfway through cooking time.
Ribeye Steak, 8 oz. each, 1" thick	Medium High	Med.-Rare 7-8 min. Medium 8-9 min. Well 9-10 min.	Turn halfway through cooking time.
T-bone Steak, 6 oz. each, 1/2" thick	Medium High	Med.-Rare 5-6 min. Medium 6-7 min. Well 7-8 min.	Turn halfway through cooking time.
T-bone Steak, 8 oz. each, 1" thick	Medium High	Med.-Rare 8-9 min. Medium 9-10 min. Well 10-11 min.	Turn halfway through cooking time.
Beef Kabobs	Medium	Well 15-20 min.	Marinate in oil and seasoning. Turn often during cooking time.
Pork			
Pork Chops, bone-in, 4-6 oz. each, 1/2" thick	Medium Low	Med. 6-7 min. Well 8-9 min.	Turn halfway through cooking time.
Pork Chops, boneless, 8 oz. each, 1 1/4" thick	Medium Low	Med. 16-17 min. Well 18-19 min.	Turn halfway through cooking time.
Bacon	Medium	Well 9-15 min.	Turn frequently while cooking
Pork Sausage Patties, 1 1/2 oz. each, 1/2" thick	Medium	Well 6-8 min.	Turn halfway through cooking time.
Spare Ribs, 1 slab, each pc 3 rib sections	Low	Well 50-60 min.	Parboil for 15 minutes before putting on grill. Cook 30 minutes, turn halfway through cooking time. Add barbeque sauce. Turn after 10-15 minutes and add sauce to other side. Cook another 10-15 min.

PLEASE NOTE: The USDA recommends that meats such as beef and lamb, etc. should be cooked to an internal temperature of 145° - 170°F, pork should be cooked to an internal temperature of 160°F - 170°F, and poultry products should be cooked to an internal temperature of 170°F - 180°F to be sure any harmful bacteria has been killed. When reheating meat/poultry products, they should also be cooked to an internal temperature of at least 165°F.

Grilling Guide (Cont.)

Food & Quantity	Temperature Setting	Approximate Cooking Time	Special Instructions
Chicken			
Whole Chicken, 3 1/2 - 5 lbs.	Low	1 - 1 3/4 hrs.	Brush with oil, Kitchen Bouquet® and seasonings. Place in a large size Reynolds® Hot Bag™. Follow directions for whole roast chicken on the grill. Turn halfway through cooking time.
Whole Chicken, cut into pieces	Medium High	Well 17-35 min.	Turn as necessary during cooking time.
Chicken Breast, boneless-skinless, 6 oz. each	Medium High	Well 15-18 min.	Turn halfway through cooking time.
Chicken Wings	Medium High	Well 15-18 min.	Turn as necessary during cooking time.
Leg Quarters	Medium High	Well 25-35 min.	Turn halfway through cooking time.
Chicken Kabobs	Medium	Well 15-20 min.	Marinate in oil and seasoning. Turn often during cooking time.
Seafood			
Tuna Steak, 1" thick	Medium	6-9 min.	Turn halfway through cooking time.
Salmon Steak, 1" thick	Medium	7-9 min.	Turn halfway through cooking time.
Orange Roughy Fillet, 1" thick	Medium Low	10-13 min.	Tuck under thin parts. Turn halfway through cooking time.
Large Black Tail Shrimp, deveined-split shell	Medium Low	4-6 min.	Turn halfway through cooking time.
Miscellaneous			
Corn on the Cob	Low	40-50 min.	Soak in husk for 20 min. and wrap in foil. Turn halfway through cooking time.
Baked Potatoes	High	1 - 1 1/4 hrs.	Pierce potatoes, oil and season skins. Wrap in foil. Turn halfway through cooking time.
Pineapple Slices, 1/2" thick	Medium	10-15 min.	Turn halfway through cooking time.

Grilling Guide (Cont.)

Food & Quantity	Temperature Setting	Approximate Cooking Time	Special Instructions
Miscellaneous			
Zucchini, 1/2" thick, sliced from end to end	Medium	10-15 min.	Brush with oil, and seasonings. Turn halfway through cooking time.
Peppers, (red, yellow & green), rings & slices, 1/2" thick	Medium	10-12 min.	Marinate in oil and seasoning. Turn halfway through cooking time
Peppers, (red, yellow & green), quartered, sliced from end to end	Medium	15-20 min.	Marinate in oil and seasoning. Turn halfway through cooking time
Bratwurst, 1" thick	Medium	Well 15-20 min.	Turn halfway through cooking time.
Cooked Ring Polish Kielbasa, 1 1/2" thick	High	12-15 min.	Turn halfway through cooking time.
Cooked Beef Bratwurst, 1" thick	High	12-15 min.	Turn halfway through cooking time.
Cooked Kielbasa, 1" thick	High	12-15 min.	Turn halfway through cooking time.
Hot Dogs, 3/4" thick	High	8-10 min.	Turn halfway through cooking time.
Jumbo Hot Dogs, 1" thick	High	10-12 min.	Turn halfway through cooking time.

Instructions For Cleaning

CAUTION: Grill surfaces are hot during use. Allow Grill Plate, Drip Tray, Lid and Grill Base to cool completely before handling and cleaning.

1. Turn the Temperature Control Knob to the LOCK/OFF position and allow the Grill to cool before disassembling and cleaning.
2. Remove the propane cylinder.
3. Remove the Grill Plate and empty the Drip Tray.
4. Wash the Grill Plate and Drip Tray with warm, soapy water and a plastic scouring pad. Rinse and dry thoroughly. Do not use steel wool, coarse scouring pads or harsh or abrasive cleaners. If necessary, use a nylon bristle brush to loosen hardened food particles.
5. Wash the inside of the Lid with a solution of mild detergent and water or use a grill cleaner with nylon bristle brush. Rinse and allow to completely air dry. Do not use a caustic grill cleaner.
6. Wash exterior parts with a soft sponge and warm clear water. Nonabrasive cleaners may also be used.
7. Use a damp cloth to clean the inside of the Grill Base.

Cleaning the Burner Assembly

IMPORTANT: Clean burner assembly prior to use after storing, at the beginning of grilling season or an inactive period of one month. Spiders and insects like to build nests in burner tubes, especially during colder months. The nests can cause fires in burner tubes or under grill.

In order to clean the inside of the burner tubes, the Burner Assembly must be removed from the Grill. Make sure the propane cylinder, Lid, Grill Plate and Drip Tray have been removed before proceeding.

1. Turn the Grill Base upside down. Refer to Figure 11 and locate the clip that holds the venturi to the Regulator Assembly. Pull straight up on the clip and set it to the side.
2. Refer to Figure 12 and locate the two machine screws that secure the Burner Assembly to the Grill. Loosen and remove these screws, making sure you retain the screws, washers and hex nuts for reassembly.

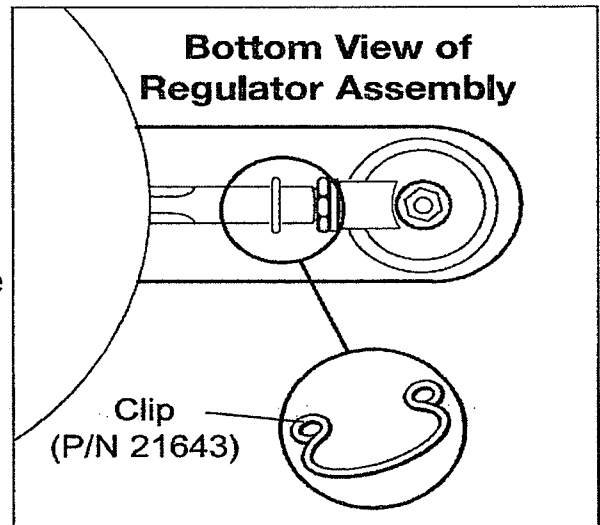

Figure 11

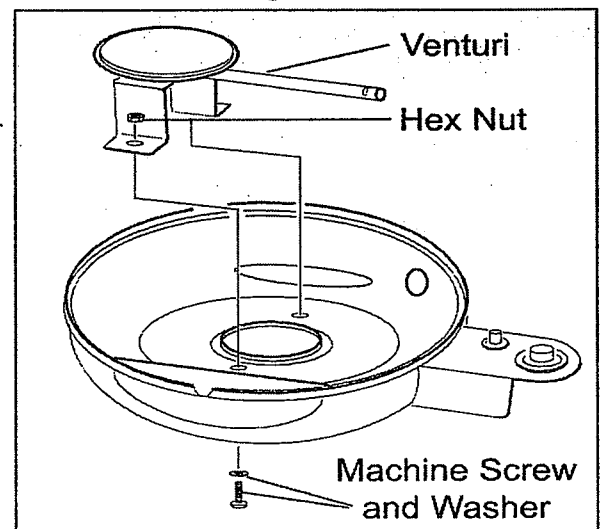

Figure 12

Instructions For Cleaning (Cont.)

3. Carefully pull back on the Burner Assembly, disengaging the venturi from the Regulator Assembly. Please see Figure 12. Since the Ignitor is still attached to the Burner Assembly, use care to avoid stressing the cable. There is enough slack available to allow you to look into the end of the venturi and clean with a pipe cleaner if needed.
4. When clean, carefully reassemble the Burner Assembly, making sure the mounting screws are tight and the venturi tube and clip are properly connected to the Regulator Assembly.
5. Clean the outside of the Burner Assembly with a paper towel or damp sponge. Open any clogged holes with a thin wire.

Storing Your Propane Grill

1. Clean the Grill as instructed above.
2. Store the propane cylinder outdoors in a well-ventilated space and out of reach of children.
3. Cover Grill when stored outdoors.
4. Store Grill indoors only if the propane cylinder is turned off and disconnected, removed from Grill and stored outdoors.
5. When removing Grill from storage, follow the "Cleaning the Burner Assembly" instructions before starting the Grill.

Any servicing requiring disassembly other than the above cleaning must be performed by an authorized appliance repair technician.

Do **NOT** ship gas cylinder if product needs service or repair.

Recipes

The Champ's Sausage Without Guilt

Try this sizzling sausage patty that not only tastes good, but is also good for you. Choose ground turkey breast, which is lower in fat than ground turkey containing dark meat and skin. Turkey, especially the light meat, is a good source of niacin, which is an important B vitamin needed to maintain a healthy nervous system. Early symptoms of niacin deficiency that appear in the nervous system are apprehension, irritability, depression, weakness, and loss of memory. To prevent niacin deficiency, include plenty of lean turkey, fish, whole wheat, potatoes, corn flower, eggs, broccoli, tomatoes, and carrots.

2 slightly beaten egg whites
2/3 cup finely chopped onion
1/2 cup finely snipped dried apples or 1 cup finely chopped fresh red
Delicious apple
1/2 cup seasoned bread crumbs
4 Tbsp. snipped fresh parsley
1 tsp. sea salt
1 tsp. ground sage
1/2 tsp. ground nutmeg
1/2 tsp. black pepper
1/4 tsp. cayenne pepper
1 lb. lean ground turkey breast

- In a medium bowl, combine all ingredients except turkey. Add the ground turkey and mix well.
- Shape the mixture into sixteen to eighteen 2-inch wide patties.
- Preheat the Grill on MED for 8 minutes.
- Place sausage on the Grill. Cover and cook for 6-7 minutes. Turn and cook another 6-7 minutes or until the meat is no longer pink and the juices run clear.
- Serves 8

This recipe is from "The Healthy Gourmet" (Clarkson Potter) by Cherie Calbom.

George's Sausage Texas Style

A spicy sausage with true Southwestern zip! These breakfast sausages are great served with a sautéed vegetable or fresh salsa and scrambled eggs. Buy 90% lean ground beef for the least-fat sausage. Ninety per-cent lean beef has 9 grams of fat with 4 of those grams being saturated fat; whereas 73% lean beef has 18 grams of fat with 7 of the grams being saturated.

2 slightly beaten egg whites
2/3 cup finely chopped onion
1/2 cup seasoned bread crumbs
1/2 cup diced green chili peppers
2 cloves (large) garlic, finely minced
4 Tbsp. snipped fresh cilantro
2 Tbsp. apple cider vinegar
1 Tbsp. chili powder
1/2 tsp. sea salt
1/4 tsp. cayenne pepper
1 lb. lean ground beef

- In a medium bowl, combine all ingredients except ground beef. Add the ground beef and mix well.
- Shape the mixture into sixteen 3-inch wide patties.
- Preheat the Grill on MED/HIGH for 8 minutes.
- Place the patties on the Grill.
- Cover and cook for 5-6 minutes. Turn and cook for another 5-6 minutes or until meat is no longer pink and the juices run clear.
- Serves 8

This recipe is from "The Healthy Gourmet" (Clarkson Potter) by Cherie Calbom.

Recipes (Cont.)

George Foreman's Power Burger

A flavorful hamburger that we think tastes even better than its all-meat cousin! It pays to eat meals that minimize meat. To reduce saturated fat in a typical burger, you can cut back on the amount of meat and make up for it with plant-based ingredients. Bread crumbs and chopped vegetables have been added in this recipe. You could also try cooked rice, other grains or cereal. In addition, choose whole wheat buns; they typically contain one less fat gram than regular or even reduced-calorie buns.

If you settle for nothing less than a cheeseburger, Swiss cheese is 1 gram lower in fat than Cheddar, American or Monterey Jack with 8 grams of fat versus 9 in each ounce of cheese. However, reduced fat cheeses like Cheddar or Swiss contain half the fat with 4 grams per ounce. Mustard contains 1 gram of fat per tablespoon versus a whopping 11 grams of fat in a tablespoon of mayonnaise.

Top your burger in healthful style with dark, leafy green lettuce, shredded cabbage, fresh cilantro, basil or spinach.

3/4 cup chopped vegetables such as yellow onions,
green onions, zucchini, parsley (can be sautéed)
3/4 cup seasoned bread crumbs
2-1/4 lbs. lean ground beef

- In a medium-size mixing bowl, combine the vegetables and bread crumbs. Add the ground beef and mix well.
- Shape the mixture into twelve 4-inch wide patties.
- Preheat the Grill on MED/HIGH for 8 minutes.
- Place the patties on the Grill.
- Cover and cook 6-8 minutes. Turn and cook another 6-7 minutes or until the meat is no longer pink and the juices run clear.
- Serves 12

This recipe is from "The Healthy Gourmet" (Clarkson Potter) by Cherie Calbom.

Grilled Vegetables

12 slices eggplant (or 8 baby eggplants)
4 small onions
4 small tomatoes
2 small zucchini
8-12 mushrooms
8 large cloves of garlic, peeled and sliced 1/4" thick
2/3 cup olive oil
4 tablespoons Italian seasoning

- Slice all vegetables 1/2 inch thick.
- Brush vegetables and garlic lightly with olive oil.
- Sprinkle Italian seasoning on both sides of vegetables and garlic.
- Preheat the Grill on MED for 8 minutes.
- Place vegetables and garlic on Grill. Cover and cook for 7-8 minutes. Turn and cook another 10-15 minutes or until desired doneness is achieved.
- Serves 6-8

Serve as an accompaniment to meat and pasta, or stuff them into a piece of pita or French bread for a grilled vegetable sandwich.

Mustard Lemon Chicken Breasts

4 tablespoons mustard
4 tablespoons balsamic vinegar
6 tablespoons lemon juice
4 cloves garlic, minced
2 tsp. paprika
8 6-oz. chicken breast, halved, boneless and skinless

- In a medium non-metal bowl, combine all ingredients except chicken.
- Add chicken breast and let it marinate for at least 1/2 hour in the refrigerator.
- Preheat the Grill on MED for 8 minutes.
- Place chicken on Grill. Cover and cook for 9-10 minutes. Turn and cook another 9-10 minutes or until meat is no longer pink and the juices run clear.
- Serves 8

Recipes (Cont.)

Rosemary Lamb Chops

16 loin lamb chops (1/2" thick)
4 tsp. chopped fresh rosemary
ground black pepper to taste

- Sprinkle chops with rosemary and pepper.
- Preheat Grill on MED/HIGH for 8 minutes.
- Place meat on Grill. Cover and cook 3-4 minutes. Turn and cook for another 3-4 minutes or until desired doneness.
- Serves 8

LIMITED ONE YEAR WARRANTY

Warranty: This George Foreman™ product is warranted by Salton, Inc. to be free from defects in materials or workmanship for a period of (1) year from the original purchase date. This product warranty covers only the original consumer purchaser of the product.

Warranty Coverage: This warranty is void if the product has been damaged by accident in shipment, unreasonable use, misuse, neglect, improper service, commercial use, repairs by unauthorized personnel, normal wear and tear, improper assembly, installation or maintenance abuse or other causes not arising out of defects in materials or workmanship. This warranty is effective only if the product is purchased and operated in the USA, and does not extend to any units which have been used in violation of written instructions furnished with the product or to units which have been altered or modified or to damage to products or parts thereof which have had the serial number removed, altered, defaced or rendered illegible.

Implied Warranties: ANY IMPLIED WARRANTIES WHICH THE PURCHASER MAY HAVE ARE LIMITED IN DURATION TO ONE (1) YEAR FROM THE DATE OF PURCHASE. Some states do not allow limitations on how long an implied warranty lasts, so the above limitation may not apply to you.

Warranty Performance: During the above one-year warranty period, a product with a defect will be either repaired or replaced with a reconditioned comparable model (at our option) when the product is returned to the Repair Center, or the purchase price refunded. The repaired or replacement product will be in warranty for the balance of the one-year warranty period and an additional one-month period. No charge will be made for such repair or replacement.

Service and Repair: Should the appliance malfunction, you should first call toll-free 1 (800) 937-3883 between the hours of 9:00 am and 5:00 pm Central Standard Time and ask for CONSUMER SERVICE stating that you are a consumer with a problem. Please refer to model number GP100 ("SIL" for silver, "BLK" for black, "BLU" for blue) when you call.

In-Warranty Service (USA): For an appliance covered under the warranty period, no charge is made for service or postage. Call for return authorization (1 800 937-3883).

Out-of Warranty Service: A flat rate charge by model is made for out-of-warranty service. Include \$20.00 (U.S.) for return shipping and handling. We will notify you by mail of the amount of the charge for service and require you to pay in advance for the repair or replacement.

For Products Purchased in the USA, but Used in Canada: You may return the product insured, packaged with sufficient protection, and postage and insurance prepaid to the USA address listed below. Please note that all customs duty / brokerage fees, if any, must be paid by you and we will require you to pay the cost of customs duty / brokerage fees to us in advance of our performing any service.

Risk During Shipment: We cannot assume responsibility for loss or damage during incoming shipment. For your protection, carefully package the product for shipment and insure it with the carrier. Be sure to enclose the following items with your appliance: any accessories related to your problem, your full return address and daytime phone number, a note describing the problem you experienced, a copy of your sales receipt or other proof of purchase to determine warranty status. C.O.D. shipments cannot be accepted.

To return the appliance, ship to:

Attn: Repair Center
Salton, Inc.
708 South Missouri Street
Macon, MO 63552

To contact us, please write to, call, or email:

Salton, Inc.
P.O. Box 1526
Columbia, MO 65205-1526
1(800) 937-3883
Email: Salton@Saltonusa.com

Limitation of Remedies: No representative or person is authorized to assume for Salton, Inc. any other liability in connection with the sale of our products. There shall be no claims for defects or failure of performance or product failure under any theory of tort, contract or commercial law including, but not limited to negligence, gross negligence, strict liability, breach of warranty and breach of contract. Repair, replacement or refund shall be the sole remedy of the purchaser under this warranty, and **in no event shall Salton be liable for any incidental or consequential damages, losses or expenses.** Some states do not allow the exclusion or limitation of incidental or consequential damages, so the above limitation or exclusion may not apply to you.

Legal Rights: This warranty gives you specific legal rights, and you may also have other rights which vary from state to state.

George Foreman™ is a trademark of Salton, Inc.

For more information on Salton products: Visit our website: <http://www.salton-maxim.com>

"© 2001 Salton, Inc.
All Rights Reserved"

P/N 60905 Rev. 3
Printed in China