

E100AVL

USER'S MANUAL

June 2012

TRADEMARKS

All brand and product names are trademarks or registered trademarks of their respective companies.

NOTE

The information in this manual is subject to change without notice.

Table of Contents

Chapter 1	Getting Started	1-1
	Getting the Tablet PC Running.....	1-2
	Unpacking	1-2
	Installing the Battery Pack and Connecting to AC Power.....	1-3
	Turning On and Off the Tablet PC	1-6
	Taking a Look at the Tablet PC.....	1-7
	Front Components.....	1-7
	Rear Components	1-9
	Right-Side Components.....	1-10
	Left-Side Components	1-11
	Top Components	1-12
	Bottom Components	1-12
Chapter 2	Operating Your Tablet PC.....	2-1
	Using the Touchscreen.....	2-2
	Using the Input Panel	2-4
	Using the Keypad.....	2-5
	Control Buttons	2-5
	Numeric Keypad with Alternative Functions.....	2-6
	Cursor-Control Keys with Alternative Functions	2-7
	Using the Network Features	2-8
	Using the LAN	2-8
	Using the Wireless LAN (Optional).....	2-9
	Using the BT Feature (Optional).....	2-11
	Turning On/Off the BT Radio.....	2-11

Chapter 3	Managing Power	3-1
	AC Adapter	3-2
	Battery Pack	3-3
	Charging the Battery Pack	3-3
	Checking the Battery Level	3-4
	Replacing the Battery Pack	3-5
	Battery Low Signals and Actions	3-7
	Power Management	3-8
	Hibernation	3-9
	Power-Saving Tips	3-10
Appendix A	Specifications	A-1
Appendix B	Regulatory Information	B-1
	USA – FCC	B-2
	Class B	B-2
	Notes	B-3
	RF Exposure Information (SAR)	B-3
	Canada – ICC	B-4
	Class B	B-4
	RSS-210	B-4
	Europe – EU Declaration of Conformity	B-7
	Notes	B-10
	Safety Notices	B-11
	About the Battery	B-11
	About the AC Adapter	B-12

Chapter 1

Getting Started

Congratulations on purchasing this rugged Tablet PC.

This chapter first tells you step by step how to get the Tablet PC up and running. Then, you will find a section briefly introducing the external components of the Tablet PC.

Getting the Tablet PC Running

Unpacking

After unpacking the shipping carton, you should find these standard items:

- Tablet PC
- Accessories:
 - AC adapter
 - AC power cord
 - Screen protector film (already attached to the screen)
 - Stylus

Inspect all the items. If any item is damaged or missing, notify your dealer immediately.

Keep the shipping carton and packing materials in case you need to ship or store the Tablet PC in the future.

Installing the Battery Pack and Connecting to AC Power

The Tablet PC operates either on the external AC power or internal battery power. It is suggested that you use AC power when starting up the Tablet PC for the very first time.

CAUTION: Use only the AC adapter included with your Tablet PC. Using other AC adapters may damage the Tablet PC.

1. Make sure that the Tablet PC is turned off.
2. Place the Tablet PC upside down.
3. Remove the rubber bumper by unfastening 6 screws (as shown below) from the bumper.

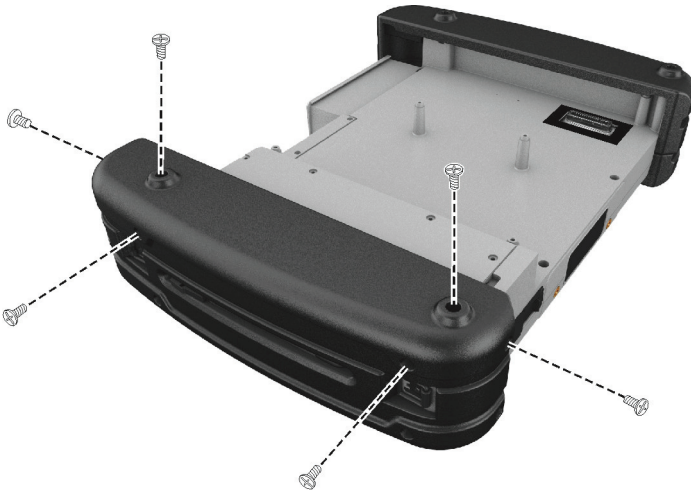

4. Remove the battery cover by unfastening 8 screws (as shown below) from the cover.

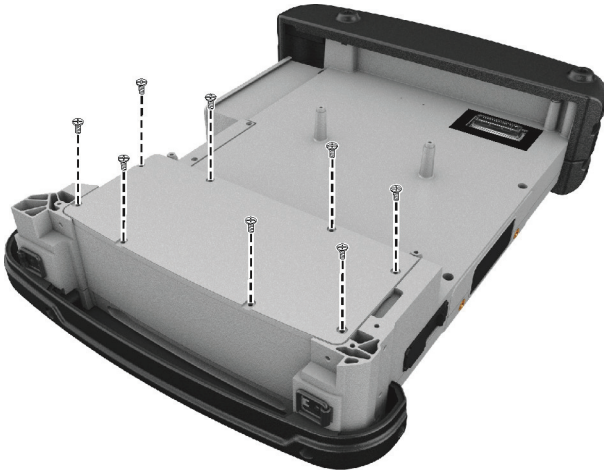

5. Fit the battery pack into place (1). Tighten two screws (2).

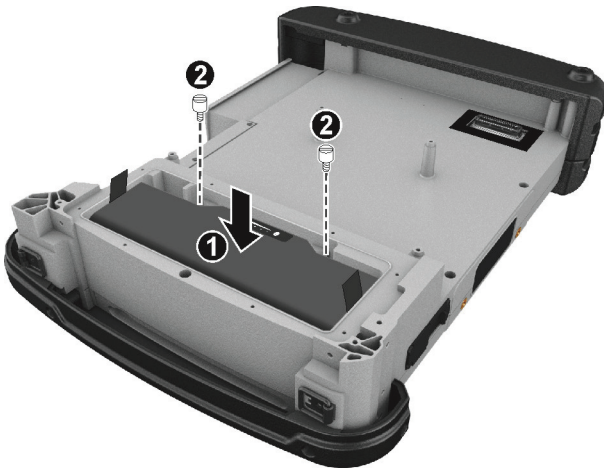

6. Replace the battery cover and the rubber bumper.

7. Plug the DC cord of the AC adapter to the power connector of the Tablet PC (❶). Plug the female end of the AC power cord to the AC adapter and the male end to an electrical outlet (❷).

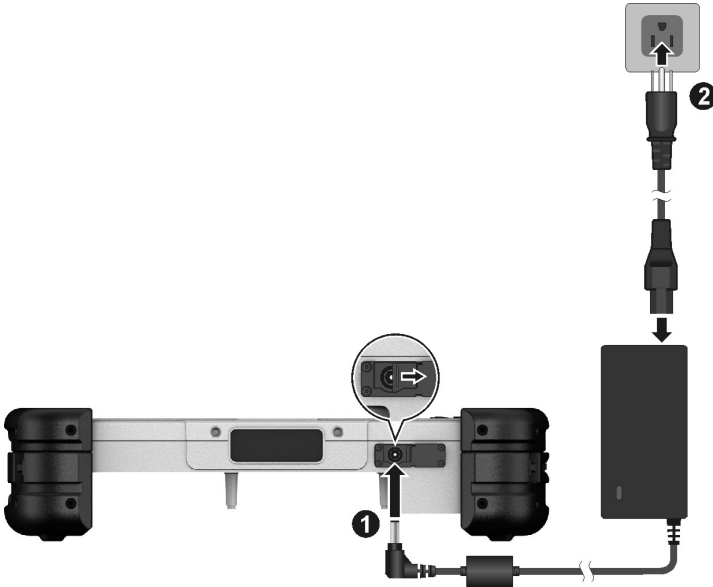

8. Power is being supplied from the electrical outlet to the AC adapter and onto your Tablet PC. Now, you are ready to turn on the Tablet PC.

CAUTION:

- When you disconnect the AC adapter, disconnect from the electrical outlet first and then from the Tablet PC. A reverse procedure may damage the AC adapter or the Tablet PC.
- When unplugging the connector, always hold the plug head. Never pull on the cord.

NOTE: When the AC adapter is connected, it also charges the battery pack. For information on using battery power, see Chapter 3.

Turning On and Off the Tablet PC

Turning On

Press the power button (⏻). The operating system such as Microsoft Windows should start.



Turning Off

When you finish a working session, you can stop the system by turning off the power or leaving it in Sleep or Hibernation mode:

To...	Do this...
Power off (Shutdown)	Use the Windows Start menu in the lower left and follow the shutdown procedure.
Sleep	Press the power button* or use the Windows Start menu to put the Tablet PC in Sleep mode.
Hibernate	Use the Windows Start menu to put the Tablet PC in Hibernation mode.

* "Sleep" is the default setting of the power button. You may change what the power button does in Windows Control Panel.

Press the power button to resume or turn on the system from any of these modes.



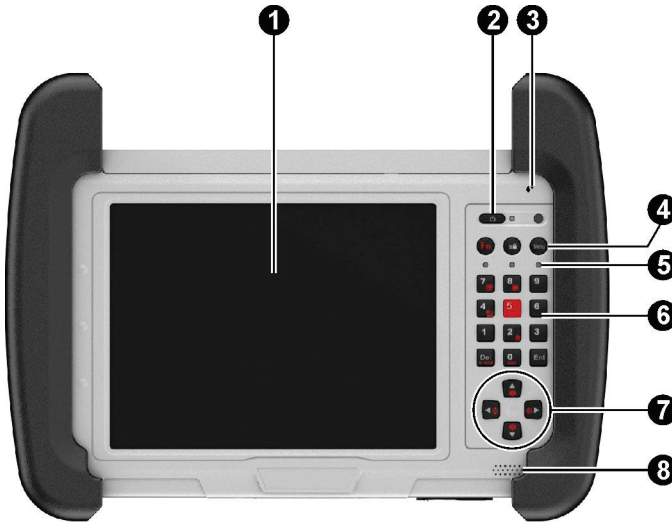

Taking a Look at the Tablet PC

NOTE: Depending on the model you purchased, the appearance of your Tablet PC may not be exactly the same as those shown in this manual.

Front Components



Ref	Component	Description
❶	Touchscreen	Displays and receives information for the Tablet PC.
❷	Power Button	Turns the power ON and OFF (Sleep mode by default). The green LED beside the button glows when the power is on and blinks when the system is in Sleep mode.
❸	Microphone	Receives sound and voice to record voice.
❹	Control Buttons	
	Fn	Toggles the Fn keylock ON and OFF.

Ref	Component	Description
		Toggles the keypad lock ON and OFF.
	Menu	Toggles the "OSD Control Panel" ON and OFF.
5	Indicators	
	RF (Radio Frequency) 	Lights green when RF radio is on.
	Battery Charge 	Lights green when the battery is fully charged.
		Lights amber when the battery is being charged.
		Blinks red (once per second) when the battery's capacity is below 10%.
		Blinks red rapidly (once per 0.5 second) when there is a thermal protection problem with the battery. Ask for repair service in case this happens.
		Blinks amber when the battery charging is in an abnormal state. Replace the battery in case this happens.
	Hard Disk Drive 	Lights green when hard disk drive is being accessed.
		Lights red when the optional heater is on during system operation.
		Blinks red when the optional heater is in an abnormal state.
6	Numeric Keypad	Provides number, Delete , and Enter keys. When Fn keylock is on, the keys provide alternative functions.
7	Cursor-control Keys	Serves as the arrow keys. When Fn keylock is on, the keys provide alternative functions.
8	Speaker	Sends out sound and voice from your Tablet PC.

Rear Components

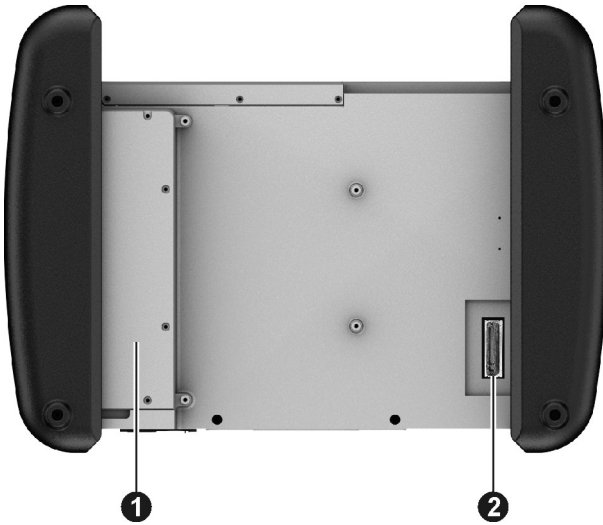

Ref	Component	Description
❶	Battery Pack	Inside is the battery pack that supplies power to your Tablet PC when external power is not connected.
❷	Docking Connector	Connects to the Docking Station (available as an option).

Right-Side Components

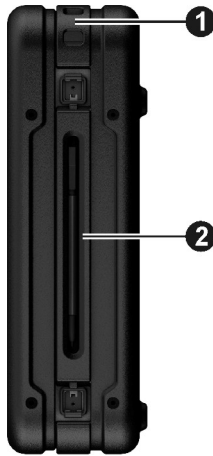

Ref	Component	Description
①	Tether Hole	Stylus tethered to this hole.
②	Stylus	Serves as the input device by tapping on the touchscreen to make selections and enter information.

Left-Side Components

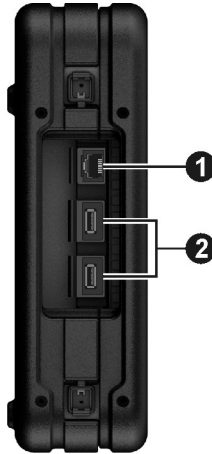

Ref	Component	Description
❶	RJ-45 Connector	Connects the LAN cable.
❷	USB Ports	Each of the two ports connects a USB device, such as a USB flash disk, printer, digital camera, joystick, and more.

Top Components

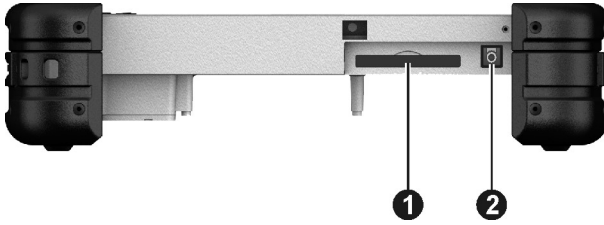

Ref	Component	Description
1	ExpressCard Slot	Accepts an ExpressCard for additional functions.
2	Headphone Out Connector	Connects a set of headphones or external speakers with amplifier

Bottom Components



Ref	Component	Description
1	Power Connector	Connects the AC adapter.

Chapter 2

Operating Your Tablet PC

This chapter provides information about the use of the Tablet PC.

If you are new to Tablet PCs, reading this chapter will help you learn the operating basics. If you are already a computer user, you may choose to read only the parts containing information unique to your Tablet PC.

CAUTION: The Tablet PC can get uncomfortably warm when you use it in high temperatures. As a safety precaution in such a circumstance, do not place the Tablet PC on your lap or touch it with your bare hands for extended periods of time. Prolonged body contact can cause discomfort and potentially a burn.

Using the Touchscreen

CAUTION: Do not use a sharp object such as a ballpoint pen or pencil on the touchscreen. Doing so may damage the touchscreen surface. Use your finger or the included stylus. A screen protector film has been attached to the screen before shipment. The film is a consumable, which will be worn out after a period of use (6 months in average). You can purchase a new one when replacement is required.

The screen of your Tablet PC is touch-sensitive. You can control the location of the cursor/pointer on the screen using your finger or the included stylus to communicate with the Tablet PC.



Here are some common terms that you should know when using the touchscreen:

Term	Action
Click/Point	Tap gently on the touchscreen.
Double-click	Tap twice on the touchscreen rapidly.
Drag and drop	Press lightly on the touchscreen and move your finger until you reach your destination (drag). Finally, release your finger (drop) when you finish dragging your selection to the destination. The object will drop into the new location.

Using the Input Panel

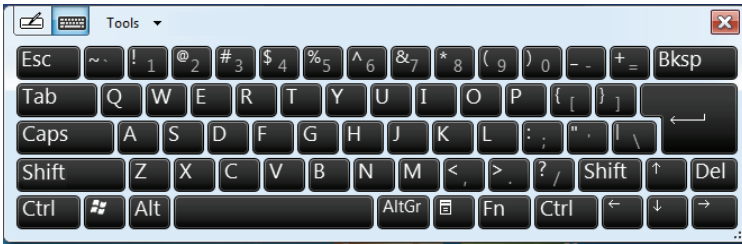

Use the Input Panel to enter text and perform various keyboard functions. There are two types of Input Panels for you to use in Windows 7:

- **Touch Keyboard** allows you to enter text by tapping the keys with your stylus, like pressing the keys on a standard keyboard.

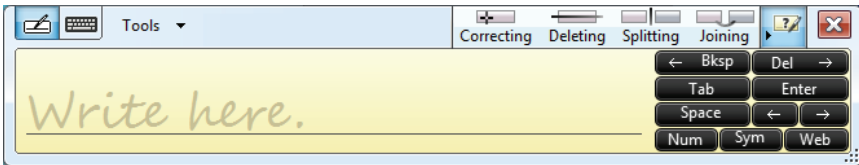

- **Writing Pad** allows you to write on the writing pad, like writing on a piece of paper. Your handwriting will be converted into typed text.



To open the Input Panel, tap the Input Panel tab, which appears by default on the left edge of the screen. To switch between the two types, tap  or  at the upper left corner of the Input Panel.

NOTE: For more information on using the Input Panel, see Windows' online help.

Using the Keypad



The keypad of your Tablet PC can be divided into three areas:

- Control buttons
- Numeric, Delete (**Del**), and Enter (**Ent**) keys
- Cursor-control keys

Control Buttons



Located on top of the keypad are three control buttons:

- **Fn** button toggles the **Fn** keylock ON and OFF. When ON (indicated by the icon  on the taskbar), you can use the alternative functions of the keypad keys (as described in the next two sections).
-  button toggles the keypad lock ON and OFF. Press the button to lock the keypad (indicated by the icon  on the taskbar) so that accidental pressing of the keypad does not result in unexpected operation. To unlock, press and hold the button for more than three second.
- **Menu** button toggles the OSD Control Panel ON and OFF.





NOTE: The status of **Fn** lock and keypad lock will persist through Sleep/Hibernation mode or system power off.

Numeric Keypad with Alternative Functions

Shown below is the 12-key numeric keypad with Delete and Enter keys.





When the **Fn** keylock is ON (indicated by the icon  on the taskbar), the keys with orange icons provide alternative functions as described below.



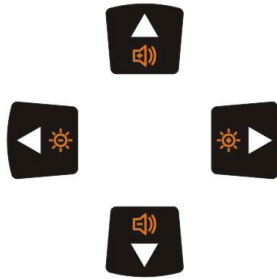

-  rotates the screen display by 90° with each press.
-  switches the keypad backlight ON and OFF.
-  switches the sunlight-readable mode ON and OFF. When ON, the display brightness is set to the highest level.
-  switches the touchscreen OFF and ON.
-  serves as the mouse right-click button.
- **C+A+D** serves as the **Ctrl+Alt+Del** key combination for resetting the system.
- **ESC** serves as the **Escape** key.

Cursor-Control Keys with Alternative Functions

Cursor-control keys control cursor movement. The word “cursor” refers to the indicator on the screen (except for pointer on screen) that lets you know exactly where on your screen anything you type will appear. It can take the form of a vertical or horizontal line, a block, or one of many other shapes.





When the **Fn** keylock is ON (indicated by the icon  on the taskbar), the keys with orange icons provide alternative functions as described below.

-  increase the sound volume.
-  decrease the sound volume.
-  increase the brightness of LCD display.
-  decrease the brightness of LCD display.

Using the Network Features

Using the LAN

The internal 10/100/1000Base-T LAN (Local Area Network) module allows you to connect your Tablet PC to a network. It supports data transfer rate up to 1000 Mbps.

To connect the network cable to the LAN module, connect one end of the LAN cable to the RJ-45 connector ( ) on the Tablet PC and the other end to the network hub.

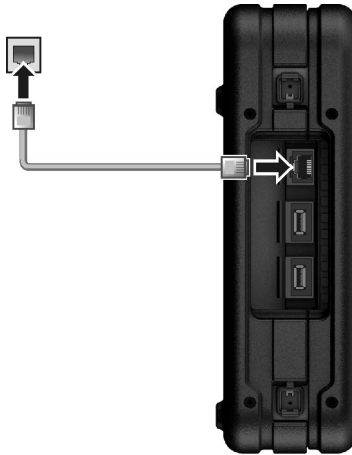

Using the Wireless LAN (Optional)

The WLAN features include:

- Peer-to-Peer (Ad-Hoc) and Access Point (Infrastructure) modes support
- WEP (Wired Equivalent Privacy) 64/128-bit data encryption
- IEEE 802.11a/b/g/n standard compliance

Technology	802.11a	802.11b/g	802.11n
Channel Center in GHz	5.18 ~ 5.825 GHz	2.412 ~ 2.472 GHz	2.412 ~ 2.472 GHz 5.18 ~ 5.825 GHz
Channel	36, 40, 44, 48, 52, 56, 60, 64, 100, 104, 108, 112, 116, 120, 124, 128, 132, 136, 140, 149, 153, 157, 161, 165	1 ~ 13	2.4 GHz: 1 ~ 13 5.2 GHz: 36 ~ 165
Data Rates (Mbps)	6, 9, 12, 18, 24, 36, 48, and 54 Mbps in OFDM mode	802.11b: 1 and 2 Mbps in DSSS mode; 5.5 and 11 Mbps in CCK mode 802.11g: 6, 9, 12, 18, 24, 36, 48, and 54 Mbps in OFDM mode	130 Mbps under the condition of 2 spatial streams, 64-QAM modulation type, 20 MHz-wide channel, and 5/6 coding rate.

Turning On/Off the WLAN Radio

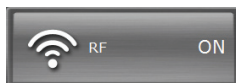

NOTE: The FAA (Federal Aviation Agency) has deemed it unsafe to operate wireless devices in aircraft as this may interfere with flight safety. Turn off wireless LAN when using your Tablet PC in the airplane.

1. Press the **Menu** button on your Tablet PC to open the OSD Control Panel.
2. Click the **RF** button to switch the wireless radio on/off. The word **ON** or **OFF** on the button indicates the current status.



- Windows Mobility Center has wireless network turned on by default. The Wireless Network icon  on the taskbar should appear without a red X. (In case you have previously turned it off in Windows Mobility Center, be sure to turn it on when using the function the next time.)

Connecting to a Wireless Network

- Make sure that the WLAN function is enabled (as described above).
- Tap the Wireless Network icon  on the taskbar. (An orange light in the icon  indicates connections are available.)
- In the list of available wireless networks, select a network, and then click **Connect**.



- Some networks require a network security key or passphrase. To connect to one of those networks, ask your network administrator or Internet service provider (ISP) for the security key or passphrase.

For more information on setting a wireless network connection, refer to Windows online help.

NOTE: You can use Intel® PROSet Wireless to take full advantage of the WiFi capabilities of your Tablet PC. See the Help of the utility for instructions.

Using the BT Feature (Optional)

The BT 4.0 technology allows short-range (about 50 meters) wireless communications between devices without requiring a cable connection. Data can be transmitted through walls, pockets and briefcases as long as two devices are within range.

Turning On/Off the BT Radio

1. Press the **Menu** button on your Tablet PC to open the OSD Control Panel.
2. Click the RF button to switch the wireless radio on/off. The word **ON** or **OFF** on the button indicates the current status.



Chapter 3

Managing Power

Your Tablet PC operates either on external AC power or on internal battery power.

This chapter tells you how you can effectively manage power. To maintain optimal battery performance, it is important that you use the battery in the proper way.

AC Adapter

CAUTION:

- The AC adapter is designed for use with your Tablet PC only. Connecting the AC adapter to another device can damage the adapter.
- The AC power cord supplied with your Tablet PC is for use in the country where you purchased your Tablet PC. If you plan to go overseas with the Tablet PC, consult your dealer for the appropriate power cord.
- When you disconnect the AC adapter, disconnect from the electrical outlet first and then from the Tablet PC. A reverse procedure may damage the AC adapter or Tablet PC.
- When unplugging the connector, always hold the plug head. Never pull on the cord.



The AC adapter serves as a converter from AC (Alternating Current) to DC (Direct Current) power because your Tablet PC runs on DC power, but an electrical outlet usually provides AC power. It also charges the battery pack when connected to AC power.

The adapter operates on any voltage in the range of 100~240 V AC.

Battery Pack

The battery pack is the internal power source for the Tablet PC. It is rechargeable using the AC adapter.

The operating time of a fully charged battery pack depends on how you are using the Tablet PC. When your applications often access peripherals, you will experience a shorter operating time.

Charging the Battery Pack

NOTE:

- Charging will not start if the battery's temperature is below 0 °C (32 °F) or above 40 °C (104 °F); the charging process will stop if the battery's temperature gets above 60 °C (140 °F). To avoid damaging the battery under this situation, disconnect the AC adapter and wait for the battery to return to room temperature before charging again.
- During charging, do not disconnect the AC adapter before the battery has been fully charged; otherwise you will get a prematurely charged battery.

To charge the battery pack, connect the AC adapter to the Tablet PC and an electrical outlet. The Battery Charge Indicator () on the Tablet PC glows amber to indicate that charging is in progress. You are advised to keep the Tablet PC power off while the battery is being charged. When the battery is fully charged, the Battery Charge Indicator glows green.

It takes approximately 2 hours to fully charge the Li-Ion battery pack at a room temperature of 25 °C (77 °F) (may need a longer charging time at lower temperatures).

CAUTION: After the Tablet PC has been fully recharged, do not immediately disconnect and reconnect the AC adapter to charge it again. Doing so may damage the battery.

NOTE: The battery level may automatically lessen due to the self-discharge process (0.21% per day), even when the battery pack is fully charged (100%). This happens no matter if the battery pack is installed in the Tablet PC.

Checking the Battery Level

NOTE: Any battery level indication is an estimated result. The actual operating time can be different from the estimated time, depending on how you are using the Tablet PC.

By Operating System

You can check the approximate battery level using the battery meter function of the operating system. To read the battery level in Windows, click the battery icon on the taskbar.

By Gas Gauge

On the exterior side of the battery pack is a gas gauge for displaying the estimated battery charge. When the battery pack is not installed in the Tablet PC and you want to know the battery charge, you can press the switch with a pointed device to see the corresponding value of indicator segment that light green.

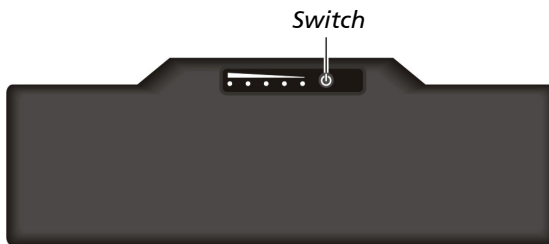

The value of the corresponding green segment indicates the relative percentage of the battery charge. The battery pack is fully discharged when you see no segment glowing green.

Replacing the Battery Pack

CAUTION:

- There is danger of explosion if the battery is incorrectly replaced. Replace the battery only with the Tablet PC manufacturer's battery packs. Discard used batteries according to the dealer's instructions.
- Do not attempt to disassemble the battery pack.

If you often rely on battery power for a long period of time while traveling, you may consider the purchase of an additional battery pack from your dealer and keep it with you in a fully charged state as a backup.

To replace the battery pack, follow these steps:

1. Make sure that the Tablet PC is not turned on or connected to AC power.
2. Remove the rubber bumper by unfastening 6 screws (as shown below) from the bumper.

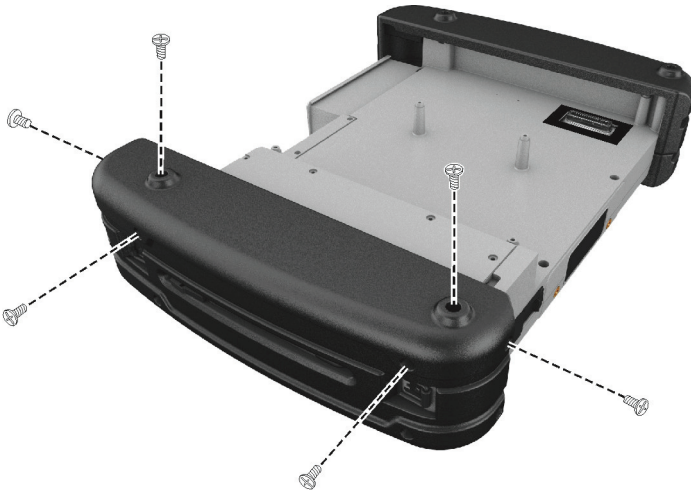

3. Remove the battery cover by unfastening 8 screws (as shown below) from the cover.

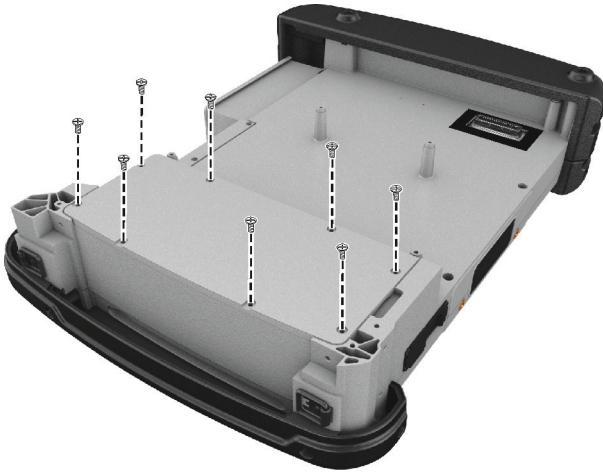

4. Remove the two screws (1). Pull the ribbon strips to lift the battery pack out of the computer (2).

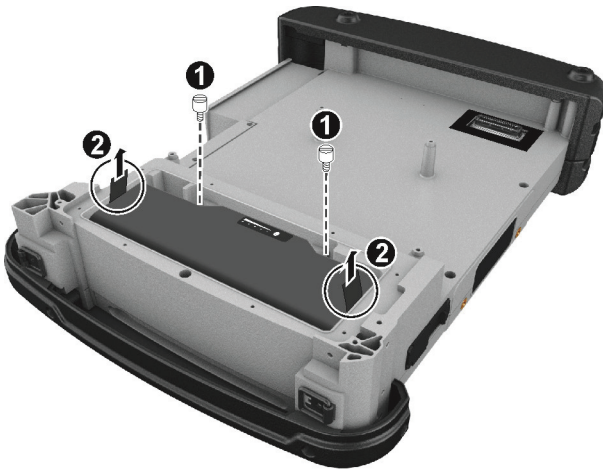

5. Fit another battery pack into place. Tighten two screws.
6. Replace the battery cover and the rubber bumper.

Battery Low Signals and Actions

When the battery is low, Windows gives warning messages and the Battery Charge Indicator () blinks red to alert you.

NOTE: You can set up your threshold and signals of Battery Low under Windows.

Immediately save your data upon Battery Low. The remaining operating time depends on how you are using the Tablet PC.

Always respond to Battery Low by placing your Tablet PC on the Sleep or Hibernation mode, turning off the Tablet PC, or connecting the AC adapter. If you do not take any action, the Tablet PC will automatically hibernate and turn off.

Power Management

Your Tablet PC supports ACPI (Advanced Configuration and Power Interface) for power management. The power management feature allows you to reduce the power consumption for energy saving.

With an ACPI-compliant operating system such as Windows, power supply to different Tablet PC components is controlled on an as-needed basis. This allows maximum power conservation and performance at the same time.

In general, Windows' power management works in this way:

What...	When...
Power to the hard disk is turned off	When the hard disk has been idle for a set period.
Power to the display is turned off	When the display has been idle for a set period.
The Tablet PC enters the Sleep mode. The hard disk and display are turned off and the entire system consumes less power.	When the entire system has been idle for a set period.
	When you manually activate the mode.
The Tablet PC enters the Hibernation mode. (See the next subsection for more information.)	When the entire system has been idle for a set period.
	When you manually activate the mode.

For detailed information on power management, see Windows' Help.

Hibernation

Hibernation is a very useful feature. People frequently open many applications when they use computers. It takes some time to get all these applications open and running, and normally they all have to be closed before the computer can be turned off.

When you use the hibernation feature, you do not have to close the applications. The Tablet PC stores the state of your Tablet PC to a file on the hard disk and then shuts down. The next time you turn on your Tablet PC, you return to exactly where you left off.

Power-Saving Tips

Aside from enabling your Tablet PC's power saving mode (see previous section), you can do your part to maximize the battery's operating time by following these suggestions.

- Do not disable Power Management.
- Decrease the LCD brightness to the lowest comfortable level.
- Shorten the length of time before Windows turn off the display.
- Many USB devices use power just by being connected. If you use a USB mouse, you can save power by disconnecting the mouse and using the optional stylus. If you use a USB flash drive, unplug it when you are not using it.
- Remove the ExpressCard (if inserted) when not using it.
- Turn off the wireless radio if you are not using the wireless module.
- Turn off the Tablet PC when you are not using it.

Appendix A

Specifications

NOTE: Specifications are subject to change without any prior notice.

Parts		Specifications
CPU		Intel® Cedar Trail N2600 1.60 GHz
Chipset		Intel® Tiger Point NM10 Express
BIOS		Phoenix, 2MB Flash EEPROM
RAM		2GB DDR3-1066 SO-DIMM
Video	Controller	Intel® GMA 3650 (Integrated in Cedar Trail)
	Display Panel	8.4-inch SVGA 800x600 LCD, sunlight readable, 500 Nits maximum brightness, resistive touchscreen, non-glare type with AR/AG film
Audio	Features	High Definition audio, volume control via keypad and software
	Speaker	Integrated speaker
	Microphone	Integrated microphone
Hard disk drive		mSATA, 32GB SSD(Solid State Drive)
I/O ports		USB (2.0) × 2, RJ-45, headphone out, ExpressCard/54, Docking
LAN		10/100/1000 Mbps Ethernet
Wireless LAN (option)		802.11 a/b/g/n
Security		TPM 1.2
Power	AC adapter	Universal 90 W; input: 100~240 V, 50/60 Hz; output: 19V
	Battery	Lithium-ion cylindrical battery, 8 cells, 2100mAh

Parts		Specifications
Dimension (LxWxD)		280×184×50mm (11×7.2×1.97 inch) (not including rubber bumper and test box)
Weight		< 2.8 kg (6.17 lb)
Environment	Temperature	Operating: -20 °C (-4 °F) to 40 °C (104 °F) Storage: -40 °C (-40 °F) to 71 °C (160 °F)
	Humidity	Relative: 0 % to 95 % non-condensing
	Compliance	MIL-STD-810G and IP65
Regulations		CE, FCC, UL

Appendix B

Regulatory Information

This appendix provides regulatory statements and safety notices on your Tablet PC.

NOTE: Marking labels located on the exterior of your Tablet PC indicate the regulations that your model complies with. Please check the marking labels and refer to the corresponding statements in this appendix. Some notices apply to specific models only.

USA – FCC

Class B

Federal Communications Commission Radio Frequency Interference Statement

This device complies with Part 15 of the FCC Rules. Operation is subject to the following two conditions: (1) this device may not cause harmful interference, and (2) this device must accept any interference received, including interference that may cause undesired operation.

NOTE:

This equipment has been tested and found to comply with the limits for a Class B digital device pursuant to Part 15 of the FCC Rules. These limits are designed to provide reasonable protection against harmful interference in a residential installation. This equipment generates, uses, and can radiate radio frequency energy and, if not installed and used in accordance with the instructions, may cause harmful interference to radio communications. However, there is no guarantee that interference will not occur in a particular installation. If this equipment does cause harmful interference to radio or television reception, which can be determined by turning the equipment off and on, the user is encouraged to try to correct the interference by one or more of the following measures:

- Reorient or relocate the receiving antenna.
- Increase the separation between the equipment and receiver.
- Connect the equipment into an outlet on a circuit different from that to which the receiver is connected.
- Consult the dealer or an experienced radio/TV technician for help.

Any changes or modifications not expressly approved by the manufacturer could void the user's authority to operate the equipment.

Please note:

The use of a non-shielded interface cable with this equipment is prohibited.

Notes

Operations in the 5.15-5.25GHz band are restricted to indoor usage only.

The country code selection is for non-US models only and is not available to all US models. Per FCC regulation, all WiFi products marketed in US must be fixed to US operation channels only.

RF Exposure Information (SAR)

This device meets the government's requirements for exposure to radio waves.

This device is designed and manufactured not to exceed the emission limits for exposure to radio frequency (RF) energy set by the Federal Communications Commission of the U.S. Government.

The exposure standard for wireless device employs a unit of measurement known as the Specific Absorption Rate, or SAR. The SAR limit set by the FCC is 1.6W/kg. Tests for SAR are conducted using standard operating positions accepted by the FCC with the device transmitting at its highest certified power level in all tested frequency bands. Although the SAR is determined at the highest certified power level, the actual SAR level of the device while operating can be well below the maximum value. This is because the device is designed to operate at multiple power levels so as to use only the power required to reach the network. In general, the closer you are to a wireless base station antenna, the lower the power output.

The highest SAR value for the device as reported to the FCC when worn on the body, as described in this user guide, is 0.817 W/kg (Body-worn measurements is depending upon available accessories and FCC requirements.)

While there may be differences between the SAR levels of various devices and at various positions, they all meet the government requirement.

The FCC has granted an Equipment Authorization for this device with all reported SAR levels evaluated as in compliance with the FCC RF exposure guidelines. SAR information on this device is on file with the FCC and can be found under the Display Grant section of www.fcc.gov/oet/ea/fccid after searching on FCC ID: QYLE100AVL.

Canada – ICC

Class B

Canadian Department of Communications Radio Interference Regulations Class B Compliance Notice

This Class B digital apparatus meets all requirements of the Canada Interference-Causing equipment regulations.

Cet appareil numérique de Classe B respecte toutes les exigences du Règlement Canadien sur le matériel brouilleur.

This digital apparatus does not exceed the Class B limits for radio noise emissions from digital apparatus set out in the Radio Interference Regulations of the Canadian Department of Communications.

Le présent appareil numérique n'émet pas de bruits radioélectriques dépassant les limites applicables aux appareils numériques de la classe B prescrites dans le Règlement sur le brouillage radioélectrique édicté par le ministère des Communications du Canada.

RSS-210

This device complies with RSS-210 of the Industry Canada Rules. Operation is subject to the following two conditions: (1) This device may not cause harmful interference, and (2) this device must accept any interference received, including interference that may cause undesired operation.

Ce dispositif est conforme à la norme CNR-210 d'Industrie Canada applicable aux appareils radio exempts de licence. Son fonctionnement est sujet aux deux conditions suivantes: (1) le dispositif ne doit pas produire de brouillage préjudiciable, et (2) ce dispositif doit accepter tout brouillage reçu, y compris un brouillage susceptible de provoquer un fonctionnement indésirable.

Caution:

(i) the device for operation in the band 5150-5250 MHz is only for indoor use to reduce the potential for harmful interference to co-channel mobile satellite systems;

(ii) the maximum antenna gain permitted for devices in the bands 5250-5350 MHz and 5470-5725 MHz shall comply with the e.i.r.p. limit; and

(iii) the maximum antenna gain permitted for devices in the band 5725-5825 MHz shall comply with the e.i.r.p. limits specified for point-to-point and non point-to-point operation as appropriate.

(iv) Users should also be advised that high-power radars are allocated as primary users (i.e. priority users) of the bands 5250-5350 MHz and 5650-5850 MHz and that these radars could cause interference and/or damage to LE-LAN devices.

Avertissement :

Le guide d'utilisation des dispositifs pour réseaux locaux doit inclure des instructions précises sur les restrictions susmentionnées, notamment :

(i) les dispositifs fonctionnant dans la bande 5 150-5 250 MHz sont réservés uniquement pour une utilisation à l'intérieur afin de réduire les risques de brouillage préjudiciable aux systèmes de satellites mobiles utilisant les mêmes canaux;

(ii) le gain maximal d'antenne permis pour les dispositifs utilisant les bandes 5 250-5 350 MHz et 5 470-5 725 MHz doit se conformer à la limite de p.i.r.e.;

(iii) le gain maximal d'antenne permis (pour les dispositifs utilisant la bande 5 725-5 825 MHz) doit se conformer à la limite de p.i.r.e. spécifiée pour l'exploitation point à point et non point à point, selon le cas.

(iv) De plus, les utilisateurs devraient aussi être avisés que les utilisateurs de radars de haute puissance sont désignés utilisateurs principaux (c.-à-d., qu'ils ont la priorité) pour les bandes 5 250-5 350 MHz et 5 650-5 850 MHz et que ces radars pourraient causer du brouillage et/ou des dommages aux dispositifs LAN-EL.

Radiation Exposure Statement:

The product comply with the Canada portable RF exposure limit set forth for an uncontrolled environment and are safe for intended operation as described in this manual. The further RF exposure reduction can be achieved if the product can be kept as far as possible from the user body or set the device to lower output power if such function is available.

Déclaration d'exposition aux radiations :

Le produit est conforme aux limites d'exposition pour les appareils portables RF pour les Etats-Unis et le Canada établies pour un environnement non contrôlé. Le produit est sûr pour un fonctionnement tel que décrit dans ce manuel. La réduction aux expositions RF peut être augmentée si l'appareil peut être conservé aussi loin que possible du corps de l'utilisateur ou que le dispositif est réglé sur la puissance de sortie la plus faible si une telle fonction est disponible.

Europe – EU Declaration of Conformity

This device complies with the essential requirements of the R&TTE Directive 1999/5/EC. The following test methods have been applied in order to prove presumption of conformity with the essential requirements of the R&TTE Directive 1999/5/EC:

EN 60950-1: 2006+A11:2009:+A1:2010+A12:2011

Safety of Information Technology Equipment

EN 62311: 2008

Assessment of electronic and electrical equipment related to human exposure restrictions for electromagnetic fields (0 Hz-300 GHz)
(IEC 62311:2007 (Modified))

EN62479:2010

EN 301 489-1 V1.9.2: 2008

Electromagnetic compatibility and Radio Spectrum Matters (ERM); ElectroMagnetic Compatibility (EMC) standard for radio equipment and services; Part 1: Common technical requirements

EN 301 489-17 V2.1.1 2009

Electromagnetic compatibility and Radio spectrum Matters (ERM); ElectroMagnetic Compatibility (EMC) standard for radio equipment and services; Part 17: Specific conditions for 2,4 GHz wideband transmission systems and 5 GHz high performance RLAN equipment

EN 300 328 V1.7.1: 2006

Electromagnetic compatibility and Radio spectrum Matters (ERM); Wideband Transmission systems; Data transmission equipment operating in the 2,4 GHz ISM band and using spread spectrum modulation techniques; Harmonized EN covering essential requirements under article 3.2 of the R&TTE Directive

EN 301 893 V1.6.1: 2008

Broadband Radio Access Networks (BRAN); 5 GHz high performance RLAN; Harmonized EN covering essential requirements of article 3.2 of the R&TTE Directive

CE 0081

Česky

Getac tímto prohlašuje, že tento E100AVL je ve shodě se základními požadavky a dalšími příslušnými ustanoveními směrnice 1999/5/ES.

Dansk

Undertegnede Getac erklærer herved, at følgende udstyr E100AVL overholder de væsentlige krav og øvrige relevante krav i direktiv 1999/5/EF.

Deutsch

Hiermit erklärt Getac, dass sich das Gerät E100AVL in Übereinstimmung mit den grundlegenden Anforderungen und den übrigen einschlägigen Bestimmungen der Richtlinie 1999/5/EG befindet.

Eesti

Käesolevaga kinnitab Getac seadme E100AVL vastavust direktiivi 1999/5/EÜ põhinõuetele ja nimetatud direktiivist tulenevatele teistele asjakohastele sätetele.

English

Hereby, Getac, declares that this E100AVL is in compliance with the essential requirements and other relevant provisions of Directive 1999/5/EC.

Español

Por medio de la presente Getac declara que el E100AVL cumple con los requisitos esenciales y cualesquiera otras disposiciones aplicables o exigibles de la Directiva 1999/5/CE.

Ελληνική

ΜΕ ΤΗΝ ΠΑΡΟΥΣΑ Getac ΔΗΛΩΝΕΙ ΟΤΙ Ε100AVL ΣΥΜΜΟΡΦΩΝΕΤΑΙ ΠΡΟΣ ΤΙΣ ΟΥΣΙΩΔΕΙΣ ΑΠΑΙΤΗΣΕΙΣ ΚΑΙ ΤΙΣ ΛΟΙΠΕΣ ΣΧΕΤΙΚΕΣ ΔΙΑΤΑΞΕΙΣ ΤΗΣ ΟΔΗΓΙΑΣ 1999/5/ΕΚ.

Français

Par la présente Getac déclare que l'appareil E100AVL est conforme aux exigences essentielles et aux autres dispositions pertinentes de la directive 1999/5/CE.

Italiano

Con la presente Getac dichiara che questo E100AVL è conforme ai requisiti essenziali ed alle altre disposizioni pertinenti stabilite dalla direttiva 1999/5/CE.

Latviski

Ar šo Getac deklarē, ka E100AVL atbilst Direktīvas 1999/5/EK būtiskajām prasībām un citiem ar to saistītajiem noteikumiem.

Lietuvių

Šiuo Getac deklaruoja, kad šis E100AVL atitinka esminius reikalavimus ir kitas 1999/5/EB Direktyvos nuostatas.

Nederlands

Hierbij verklaart Getac dat het toestel E100AVL in overeenstemming is met de essentiële eisen en de andere relevante bepalingen van richtlijn 1999/5/EG.

Malti

Hawnhekk, Getac, jiddikjara li dan E100AVL jikkonforma mal-ħtiġijiet essenzjali u ma provvedimenti oħrajn relevanti li hemm fid-Direttiva 1999/5/EC.

Magyar

Alulírott, Getac nyilatkozom, hogy a E100AVL megfelel a vonatkozó alapvető követelményeknek és az 1999/5/EC irányelv egyéb előírásainak.

Polski

Niniejszym Getac oświadcza, że E100AVL jest zgodny z zasadniczymi wymogami oraz pozostałymi stosownymi postanowieniami Dyrektywy 1999/5/EC.

Portuguê

Getac declara que este E100AVL está conforme com os requisitos essenciais e outras disposições da Directiva 1999/5/CE.

Slovensko

Getac izjavlja, da je ta E100AVL v skladu z bistvenimi zahtevami in ostalimi relevantnimi določili direktive 1999/5/ES.

Slovensky

Getac týmto vyhlasuje, že E100AVL spĺňa základné požiadavky a všetky príslušné ustanovenia Smernice 1999/5/ES.

Suomi

Getac vakuuttaa täten että [type of equipment = laitteen tyyppimerkintä] tyyppinen laite on direktiivin 1999/5/EY oleellisten vaatimusten ja sitä koskevien direktiivin muiden ehtojen mukainen.

Svenska

Härmed intygar Getac att denna [utrustningstyp] står i överensstämmelse med de väsentliga egenskapskrav och övriga relevanta bestämmelser som framgår av direktiv 1999/5/EG.

Notes

This device is a 2.4 GHz wideband transmission system (transceiver), intended for use in all EU member states and EFTA countries, except in France and Italy where restrictive use applies.

In Italy the end-user should apply for a license at the national spectrum authorities in order to obtain authorization to use the device for setting up outdoor radio links and/or for supplying public access to telecommunications and/or network services.

This device may not be used for setting up outdoor radio links in France and in some areas the RF output power may be limited to 10 mW EIRP in the frequency range of 2454 – 2483.5 MHz. For detailed information the end-user should contact the national spectrum authority in France.

Safety Notices

About the Battery

Caution Texts Concerning Lithium Batteries

DANISH

ADVARSEL! Lithiumbatteri – Eksplosionsfare ved fejlagtig håndtering. Udskiftning må kun ske med batteri af samme fabrikat og type. Levér det brugte batteri tilbage til leverandøren.

NORWEGIAN

ADVARSEL: Eksplosjonsfare ved feilaktig skifte av batteri. Benytt samme batteritype eller en tilsvarende type anbefalt av apparatfabrikanten. Brukte batterier kasseres i henhold til fabrikantens instruksjoner.

SWEDISH

VARNING: Explosionsfara vid felaktigt batteribyte. Använd samma batterityp eller en ekvivalent typ som rekommenderas av apparattillverkaren. Kassera använt batteri enligt fabrikantens instruktion.

FINNISH

VAROITUS: Paristo voi räjähtää, jos se on virheellisesti asennettu. Vaihda paristo ainoastaan valmistajan suosittelemaan tyyppiin. Hävitä käytetty paristo valmistajan ohjeiden mukaisesti.

ENGLISH

CAUTION: Danger of explosion if battery is incorrectly replaced. Replace only with the same or equivalent type recommended by the equipment manufacturer. Discard used batteries according to manufacturer's instructions.

DEUTSCH

VORSICHT: Explosionsgefahr bei unsachgemäßem Austausch der Batterie. Ersatz nur durch denselben oder einen vom Hersteller empfohlenen gleich-wertigen Typ. Entsorgung gebrauchter Batterien nach Angaben des Herstellers.

FRENCH

ATTENTION: Il y a danger d'explosion s'il y a un remplacement incorrect de la batterie. Remplacer uniquement avec une batterie du même type ou d'un type équivalent recommandé par le constructeur. Mettre au rebut les batteries usagées conformément aux instructions du fabricant.

Attention (for USA Users)

The product that you have purchased contains a rechargeable battery. The battery is recyclable. At the end of its useful life, under various state and local laws, it may be illegal to dispose of this battery into the municipal waste stream. Check with your local solid waste officials for details in your area for recycling options or proper disposal.

About the AC Adapter

- Use only the AC adapter supplied with your Tablet PC. Use of another type of AC adapter will result in malfunction and/or danger.
- Do not use the adapter in a high moisture environment. Never touch the adapter when your hands or feet are wet.
- Allow adequate ventilation around the adapter when using it to operate the device or charge the battery. Do not cover the AC adapter with paper or other objects that will reduce cooling. Do not use the AC adapter while it is inside a carrying case.
- Connect the adapter to a proper power source. The voltage requirements are found on the product case and/or packaging.
- Do not use the adapter if the cord becomes damaged.
- Do not attempt to service the unit. There are no serviceable parts inside. Replace the unit if it is damaged or exposed to excess moisture.