

The handset at a glance

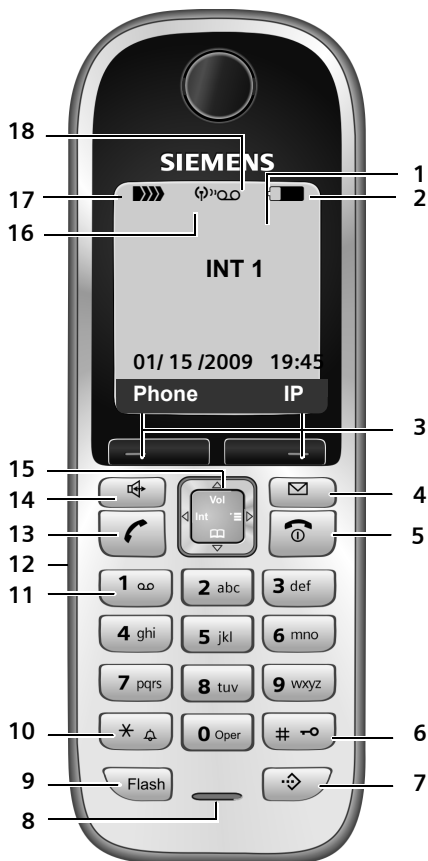

- 6 Pound key (#)**
Keypad lock on/off (press and hold)
(→ [Page 37](#))
Switch between upper/lower case letters and digits for text input (→ [Page 203](#))
- 7 Quick list key (not for VoIP)**
Open Quick list
- 8 Microphone**
- 9 Flash key**
Fixed line network:
Enter flash (press briefly)
Enter pause (press and hold)
VoIP: enter flash (adjustable, → [Page 175](#))
- 10 Asterisk key (*)**
Idle status: ringers on/off (press and hold)
Fixed line network: switch between dial pulsing/tone dialing
Editor: open table with special characters
- 11 Key 1 (press and hold)**
Call network mailbox or answering machine
- 12 Connection socket for headset**
(→ [Page 32](#))
- 13 Talk key**
Answer call, open Last Number Redial list (press briefly in idle status), select connection type and start dialing (press briefly/press and hold after entering the number, → [Page 45](#))
- 14 Speaker key**
Switch between speaker/earpiece modes
Lights up: speaker activated
Flashes: incoming call
- 15 Control key (→ [Page 34](#))**
- 16 Eco mode activated (→ [Page 109](#))**
- 17 Signal strength**
■>>> ■>>> ■>>> (low to high)
□>>> flashes: no reception
- 18 Answering machine icon**
Answering machine switched on;
Flashes: Answering machine is recording a message or is being operated by another internal party

Handset keys

- 1 Display in idle status (example)
- 2 **Charge status of the batteries**
 - >>> ■>>> ■>>> (1/3 charged to fully charged)
 - >>> flashes: battery almost empty
 - >>> ■>>> ■>>> flashes: battery charging
- 3 **Display keys (→ [Page 35](#))**
- 4 **Message key**
Opens Calls and Message lists
Flashes: new message, new call or new firmware/new provider profile available
- 5 **End Call key, On/Off key**
End call, cancel function, go back one menu level (press briefly), back to idle status (press and hold), activate/deactivate handset (press and hold in idle status)

Overview of display icons

Overview of display icons



Charge status of the batteries (empty to fully charged)

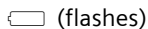

(flashes)

Batteries almost empty



(flashes)

Charging



Reception signal strength between the base station and the handset (low to high)



D))) (flashes)

No reception signal between the base station and the handset



Eco mode switched on



In header:

Solid: Base station answering machine is switched on

Flashes: Answering machine is recording a message or is being operated

Otherwise:

New message on a network mailbox or the local answering machine



Incoming call (ringer icon)



New call in the Calls list



New message in Messenger or E-mail list



Keypad lock activated



Ringer deactivated



Alert tone switched on



Alarm clock set

The base station at a glance

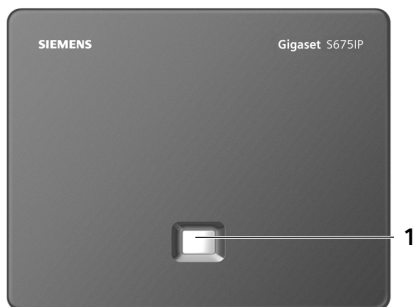

Base station key

1 Paging key

Lights up:

LAN connection active (phone is connected to router)

Flashes:

data transfer to LAN connection

Press **briefly**:

Start paging (→ [Page 114](#)), display IP address on handset

Press and **hold**:

Set base station to registration mode (→ [Page 113](#))

Contents

The handset at a glance	1
Overview of display icons	2
The base station at a glance	2
Safety precautions	8
Gigaset S675 IP – more than just making calls	9
VoIP – making calls via the Internet	10
Gigaset HDSP – telephony with brilliant sound quality	11
First steps	12
Checking the package contents	12
Setting up the handset for use	14
Installing the base station	19
Connecting the base station	19
Making settings for VoIP telephony	24
Attaching the belt clip and headset	32
What would you like to do next?	33
Operating the handset	34
Using the Control key	34
Using the Display keys	35
Using the keys on the keypad	35
Correcting text entry errors	35
Using the menus	36
Reverting to idle status	37
Activating/deactivating the handset	37
Activating/deactivating the keypad lock	37
Using this guide	37
Menu trees	40
Phone menu	40
Web configurator menu	44
Making calls with VoIP and the fixed line network	45
Making an external call	45
Ending a call	48
Accepting a call	49
Caller ID	49
Using speaker mode	52
Deactivating your handset's microphone	53
Muting the handset	54

Contents

VoIP telephony via Gigaset.net	54
Opening the Gigaset.net directory	55
Searching for subscribers in the Gigaset.net directory	56
Managing your own entry	58
Calling a Gigaset.net subscriber	59
Making calls via network services	60
Blocking your caller ID – Anonymous calling	60
Further network services in the fixed line network	61
Further network services for VoIP	61
Using lists	65
Using the Last Number Redial list	65
Opening lists with the Message key	66
Using directories and Quick list	70
Handset directory/Quick list	70
Setting up Cost-effective calling	76
Managing E-mails	77
Opening the Incoming Mail list	77
Reading e-mail messages	79
Viewing e-mail sender's address	80
Deleting e-mail messages	80
Using the Instant Messenger (IM)	81
Establishing a connection, going online	82
Changing/checking your personal status, going offline	83
Opening the Buddy list	84
Receiving messages	86
Writing and sending messages	88
Calling a buddy	89
Self-help with errors	90
Info Center – with the handset always online	91
Starting Info Center, selecting info services	91
Registering for personalized info services	92
Operating the Info Center	93
Displaying information from the Internet as a screensaver	95
Operating the base station answering machine	96
Using the handset	96
Activating/deactivating call screening	102
Setting up the answering machine	102
Configuring the answering machine for fast access	104
Operating remotely	104
Using the network mailbox	106
Activating/deactivating the network mailbox, entering numbers	106
Configuring the (network) mailbox for fast access	107
Listening to messages on the network mailbox	108

ECO DECT: Conserving energy	109
Setting an appointment (calendar)	110
Saving an appointment	110
Managing appointments	111
Deactivating or answering an appointment reminder	111
Displaying missed appointments, anniversaries	111
Setting the alarm clock	112
Activating/deactivating and setting the alarm clock	112
Deactivating the wake-up call/repeating after a pause (snooze mode) ...	112
Using multiples handsets	113
Registering handsets	113
De-registering handsets	114
Locating a handset ("paging")	114
Changing the base station	115
Changing a handset's internal number	115
Changing the name of a handset	116
Making internal calls	116
Using a handset as a room monitor	118
Handset settings	121
Changing the display language	121
Setting the display	122
Setting the screensaver	122
Setting the display backlight	123
Quickly accessing functions and numbers	124
Activating/deactivating auto answer	126
Changing the speaker/earpiece volume	126
Changing ringers	127
Activating/deactivating advisory tones	129
Managing My stuff	130
Setting your own area code	131
Restoring the handset default settings	131
Setting the base station via the handset	132
Protecting against unauthorized access	132
Restoring the base station to the factory settings	133
Activating/deactivating music on hold	134
Setting default connection	134
Entering local and extra area codes	135
Updating the base station firmware	136

Contents

Making VoIP settings	137
Using the connection assistant	137
Changing settings without the connection assistant	137
Setting the phone's IP address in LAN	139
Activating/deactivating the display of VoIP status messages	140
Checking the base station MAC address	141
Operating the base station on the PABX	141
Changing the dialing mode	141
Setting Flash	141
Setting access codes (external line prefixes)	142
Setting pauses	142
Switching temporarily to tone dialing (DTMF)	143
Setting the phone with the PC	144
Connecting the PC with the telephone's Web configurator	144
Logging in, setting the Web configurator language	146
Logging off	146
Using the Web pages	147
Menu bar	147
Navigation area	148
Working area	148
Buttons	149
Opening Web pages	149
Setting the phone with the Web configurator	150
Configuring the IP	151
Configuring telephone connections	154
Optimizing voice quality for VoIP connections	163
Setting the telephone's default connection	167
Activating the fixed line network connection as an alternate connection .	168
Assigning send and receive numbers to handsets	168
Assigning receive numbers to the answering machine	170
Activating Call Forwarding for VoIP connections	170
Entering your own area code, activating/deactivating an automatic area code for VoIP	171
Defining dialing plans – cost control	172
Activating/deactivating network mailbox, entering numbers	174
Setting DTMF signaling for VoIP	175
Defining Flash key functions for VoIP (hook flash)	175
Configuring call forwarding via VoIP	176
Defining local communication ports for VoIP	177
Saving messenger access data	179
Configuring incoming e-mail	181
Configuring info services/activating idle display	181
Changing internal handset numbers and names	182
Transferring handset directories to/from the PC	183
Activating VoIP status message display	185
Starting a firmware update	185

Contents

Activating/deactivating the automatic version check	187
Copying the date/time from time server	187
Querying the phone status	189
Getting help with your phone	190
Questions and answers	190
Using VoIP status codes	194
Checking service information	197
Protecting our environment	199
Our environmental mission statement	199
Appendix	200
Care	200
Contact with liquid	200
Specifications	200
Writing and editing text	202
Industry Canada Certification	206
FCC / ACTA Information	207
Safety precautions	209
Service (Customer Care)	211
End-user limited warranty	211
Gigaset S675 IP – free software	215
Accessories	223
Glossary	224
Index	237
Mounting the charging cradle to the wall	250
Mounting the base station to the wall	250

Safety precautions

Safety precautions

Warning

Be sure to read this user guide and the safety precautions before using your telephone. Explain their content and the potential hazards associated with using the telephone to your children.



Use only the power adapter supplied, as indicated on the underside of the base station or charging cradle.



Use only the **recommended, rechargeable batteries** (→ [Page 200](#)). Using conventional (non-rechargeable) batteries or other types of batteries could result in significant health risks and personal injury. Do not charge the handset in the charging unit or base station while the headset is connected.



Using your telephone may affect nearby medical equipment. Be aware of the technical conditions in your particular environment, e.g. doctor's surgery.



Do not hold the rear of the handset to your ear when it is ringing or when the speaker function is activated. Otherwise you risk serious and permanent damage to your hearing.

The handset may cause an unpleasant humming noise in hearing aids.



Do not install the base station or charging cradle in bathrooms or shower rooms. The handset, base station and charging cradle are not waterproof (→ [Page 200](#)).



Do not use the phone in environments with a potential explosion hazard, e.g. paint shops.



If you give your phone to a third party, make sure you also give them the user guide.



Remove faulty base stations from use, as they could interfere with other wireless services.

Warning

When the keypad lock is active, you cannot call emergency numbers!

Please note

Not all of the functions described in this user guide are available in all countries.

Gigaset S675 IP – more than just making calls

You can use your phone to make calls both via the fixed line network and also (cost effectively) via the Internet (VoIP) **without a PC**.

Your phone can do much more:

- ◆ Make calls with brilliant sound quality using **High Definition Sound Performance (HDSP)** for either internal calls or calls made via VoIP (→ [Page 11](#)) – for internal calls or calls via VoIP.
- ◆ A simple **press of a button** each time you make a call indicates whether you want to call via the fixed line network or the Internet (→ [Page 45](#)).
- ◆ Register up to **six** handsets on your base station. With your base station, you can simultaneously conduct two calls via VoIP and one call via the fixed line network.
- ◆ **Multiline:** Create up to six VoIP accounts with different VoIP providers. Together with your fixed line number and the Gigaset.net number, your phone can then be reached via up to **eight different phone numbers**.
- ◆ Assign each handset its own VoIP number as a send and receive number. If a member of your family is called on their VoIP number, only their handset will ring (→ [Page 168](#)).
- ◆ You can also use the VoIP accounts with different providers for cost control purposes. When dialing, specify the VoIP connection/VoIP account that you want to use for its lower rates (→ [Page 47](#)).
- ◆ Setting dialing plans for phone numbers or area codes enables you to automate the selection of the most cost-effective VoIP connection (→ [Page 172](#)).
- ◆ Specify the phone numbers for which the answering machine will accept calls (→ [Page 170](#)).
- ◆ Use Gigaset.net for VoIP calls. Connect your phone to the electrical power supply and the Internet and enjoy free phone calls on Gigaset.net – without making any further settings (→ [Page 54](#)).
- ◆ Configure the phone connection for VoIP without a PC. Your phone's connection assistant downloads general data about your VoIP provider from the Internet and guides you through entering your personal data (VoIP/SIP account). This makes it easy for you to start using VoIP (→ [Page 24](#)).
- ◆ If necessary, make any further VoIP settings on a PC. The phone features a Web interface (**Web configurator**) that can be accessed via your PC's Web browser (→ [Page 144](#)).
- ◆ Use **instant messaging** on your handset. Go online and see which of your messenger contacts (buddies) are also online. Exchange messages with your buddies, or just call them (→ [Page 81](#)). A free messenger account has already been set up for you on the Gigaset.net Jabber server (→ [Page 180](#)).
- ◆ Obtain information about new **e-mail** messages in your mailbox from your phone **without using a PC** (→ [Page 77](#)). Use your handset to delete unwanted e-mail messages from your mailbox.

VoIP – making calls via the Internet

- ◆ Make sure your phone is always up-to-date. Keep yourself informed about **firmware updates** on the Internet and download them onto your phone (→ [Page 136](#)).
- ◆ Reduce your phone's transmission power by switching on **Eco Mode** (→ [Page 109](#)).

Your Gigaset S675 IP has a protected operating system that offers **increased security against viruses** from the Internet.

Have fun using your new phone!

VoIP – making calls via the Internet

With VoIP (Voice over Internet Protocol), your calls are not made via a fixed connection as with the telephone network, but rather they are transmitted via the Internet in the form of data packets.

You can take advantage of all the benefits of VoIP with your phone:

- ◆ You can make cost-effective calls in high voice quality with callers on the Internet, the fixed line network or the cell phone network.
- ◆ VoIP providers will give you personal numbers, with which you can be reached from the Internet, the fixed line network and any cell phone network.

To use VoIP, you need:

- ◆ A broadband Internet connection (e.g. DSL) with flat rate (recommended) or volume-based price.
- ◆ Internet access, i.e. you need a router that will connect your phone to the Internet.

You can find a list of recommended routers on the Internet at:

www.gigaset.com/customer-care

From here, go to the FAQ page and select your Gigaset-IP phone. Search for "Router", for example.

- ◆ Access the services of a VoIP provider. You can open up to six accounts with **different** VoIP providers.

Gigaset HDSP – telephony with brilliant sound quality



Your Gigaset IP phone supports the broadband codec G.722. With your base station and the corresponding handset, you can make calls via VoIP with brilliant sound quality (High Definition Sound Performance).

If you register further broadband-capable handsets (e.g. Gigaset S67H, S68H or SL37H) with your base station, internal calls between these handsets will also be conducted via broadband.

Prerequisites for broadband connections to your base station are:

◆ **For internal calls:**

Both handsets are broadband-capable, i.e. both of them support codec G.722.

◆ **For external calls via VoIP:**

- You make the call from a broadband-capable handset.
- You have selected codec G.722 for outgoing calls (→ [Page 163](#)).
- Your VoIP provider supports broadband connections.
- The recipient's phone supports codec G.722 and accepts broadband connections.

Please note

The VoIP service [Gigaset.net](#) (→ [Page 54](#)) supports broadband connections.

First steps

First steps

Checking the package contents

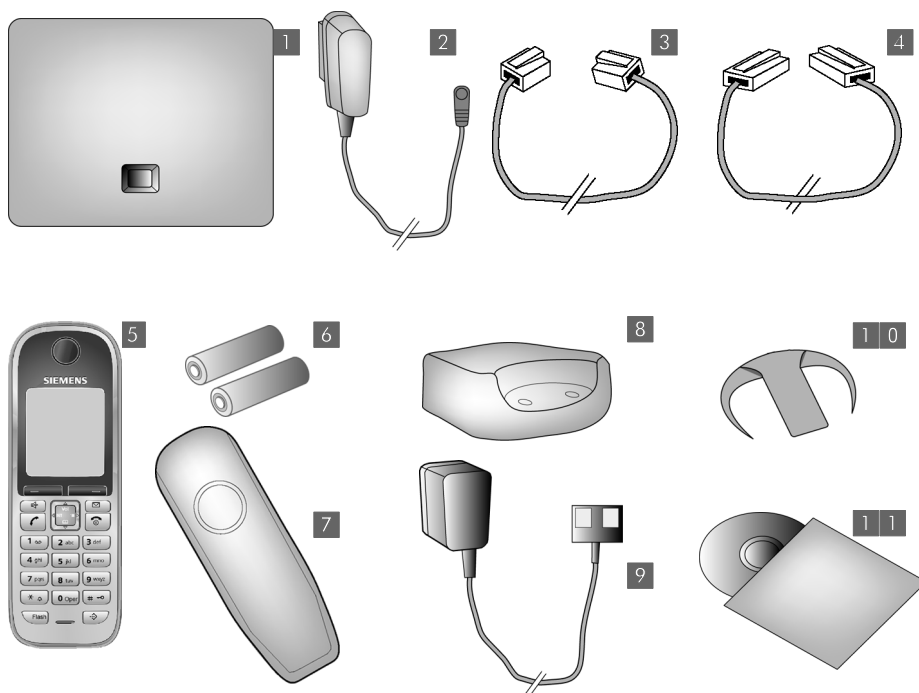

- 1** one Gigaset S675 IP base station
- 2** one power adapter for connecting the base station to the electrical power supply
- 3** one phone cord for connecting the base station to the fixed line network
- 4** one Ethernet (LAN) cable for connecting the base station to the router (LAN/Internet)
- 5** one Gigaset S67H handset
- 6** two batteries for the handset (uncharged)
- 7** one battery compartment cover for the handset
- 8** one handset charging cradle
- 9** one power adapter for connecting the charging cradle to the electrical power supply
- 10** one belt clip for the handset
- 11** one quick guide and a CD containing this user guide

Firmware updates

This user guide describes the basic functions from firmware version 179.

Whenever there are new or improved functions for your Gigaset S675, base station firmware updates are made available for you to download to your telephone (→ **Page 136**). If this results in operational changes to your phone, a new version of this user guide or the necessary amendments is published on the Internet at www.gigaset.com

Select "Gigaset S675 IP" to open the relevant product page for your phone, where you will find a link to the user guide.

For information on finding the current firmware version of your base station, → **Page 189** (using the Web configurator) or → **Page 197** (during an external call).

First steps

Setting up the handset for use



The display is protected by a plastic film. **Please remove the protective film!**

Inserting the batteries and closing the battery cover

Warning

Use only the recommended, rechargeable batteries (→ [Page 200](#)). Using conventional (non-rechargeable) batteries or other types of batteries could result in significant health risks and personal injury. For example, the outer casing of the batteries could be destroyed or the batteries could explode. The phone could also malfunction or be damaged as a result of using batteries that are not of the recommended type.

- ▶ Insert the batteries with the polarity in the correct direction. The polarity is indicated in/on the battery compartment.

The handset is activated automatically. You will hear a confirmation tone.

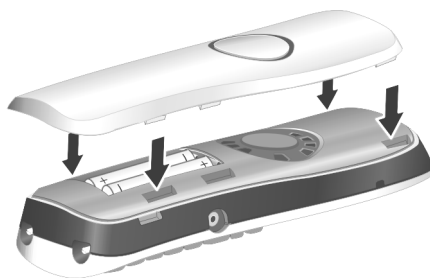

- ▶ First align the notches on the side of the battery cover with the lugs on the inside of the casing.
- ▶ Then press the cover until it clicks into place.

- ▶ To open the battery cover, for instance to replace the batteries, remove the belt clip (if attached). Insert a coin into the cavity on the casing, then pull the battery cover in an upward direction.

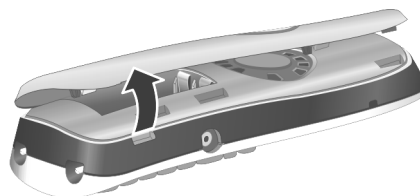

Connecting the charging cradle

The charging cradle is designed to be operated in enclosed, dry areas at temperatures ranging from +41°F to +113°F.

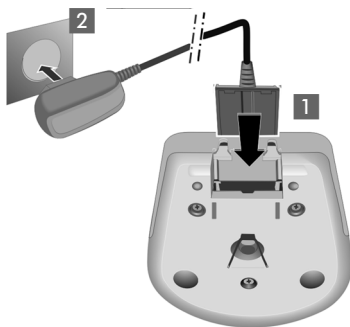

- ▶ Connect the empty plug from the power adapter **1**.
- ▶ Plug the electrical adapter into the plug socket **2**.

To disconnect the plug from the charging cradle, press the release button **1** and disconnect the plug **2**.

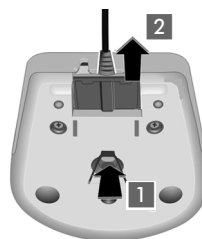

- ▶ To charge the batteries, leave the handset in the charging cradle.

Please note

- ◆ Only place the handset in the charging cradle for which it is intended.
- ◆ If the handset has turned itself off because the batteries are empty and is then placed in the charging cradle, it will turn itself on automatically.

For information on attaching the charging cradle to the wall, → [Page 250](#).

If you have any questions or problems → [Page 190](#).

Initial charging and discharging of the batteries

- ▶ Place the handset in the charging cradle and wait until the batteries are fully charged (approx. **10 hours**).

If the handset is switched on, battery charging is indicated in the top right of the display by the flashing battery icon



- ▶ Remove the handset from the charging cradle and do not replace it until the batteries are fully discharged.

The charge status is displayed in the idle display.

(empty to full) flashes, the batteries are almost empty.

First steps

After the first battery charge **and** discharge, you may place your handset in the charging cradle after every call.

Warning

- ◆ Always repeat the charging and discharging procedure if you remove the batteries from the handset and reinsert them.
- ◆ The batteries may warm up during charging. This is not dangerous.
- ◆ After a while, the charge capacity of the batteries will decrease for technical reasons.

Setting the date and time

The date and time must be set to have the correct time for incoming calls and to use the alarm clock and calendar.

Please note

The address of a time server on the Internet is stored on your telephone. The date and time are taken from this time server provided that the base station is connected to the Internet and synchronization with the time server is activated (→ [Page 187](#)). Manual settings are overwritten in this case.

If the date and time have not yet been set on the phone, the Display key **Time** is displayed.

Setting up manually:



- ▶ Press the key below **Time** (right Display key) on the display screen.



You will see the following display screen for multiple line input. Each active line is marked with [...].



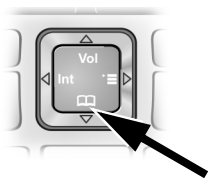

- ▶ Overwrite the date currently displayed: enter the month, day and year (8 digits) via the keypad, e.g. **0** **1** **2** **2** **0** **9** for 1/ 22 /2009.

First steps

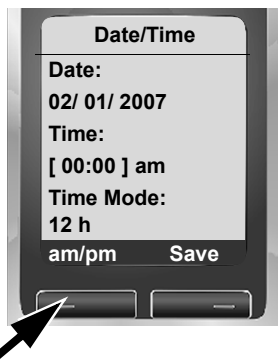

- ▶ Press the bottom of the Control key  to switch to the line for entering the time.



- ▶ Overwrite the time currently displayed: enter hours and minutes (4 digits) via the keypad, e.g.     for 7:15. If necessary, use the Control key to swap between fields.
- ▶ If necessary, press the left Display key  to switch between am and pm.

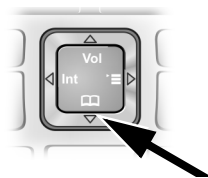

- ▶ Press the bottom of the Control key  to switch to the next line for setting the time mode.



- ▶ Press the Control key  once on the left or right to switch from 12 h mode to 24 h mode.

First steps



- ▶ Press the right Display key **Save** to save the date and time settings.

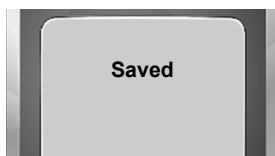

- The display shows **Saved**.
You will hear a confirmation tone.

The date and time are shown in the handset's idle display mode (→ [Page 1](#)).

Registering the handset to the base station

Your handset is registered to the base station by default.

For information on how to register additional handsets with the base station and make free internal calls, see [Page 113](#).

Installing the base station

The base station is designed for use in closed, dry rooms with a temperature range of +41°F to +113°F.

- ▶ Set or hang the base station up at a central location in your house or apartment.

Please note

Consider the range of the base station.

This is up to 328 yards in unobstructed outdoor areas and up to 54 yards inside buildings. The range is reduced when eco mode is activated (→ [Page 109](#)).

The phone's feet do not usually leave any marks on surfaces. However, due to the multitude of different varnishes and polishes used on today's furnishings, the occurrence of marks on the surfaces cannot be completely ruled out.

For information on mounting the base station on the wall, see [Page 250](#).

Warning

- ◆ Never expose the telephone to any of the following: heat sources, direct sunlight or other electrical appliances.
 - ◆ Protect your Gigaset from moisture, dust, corrosive liquids and fumes.
-

Connecting the base station

To make calls with your phone via the fixed line network and via VoIP, you must connect the base station to the fixed line network and the Internet,

- [Figure 1](#).

First steps

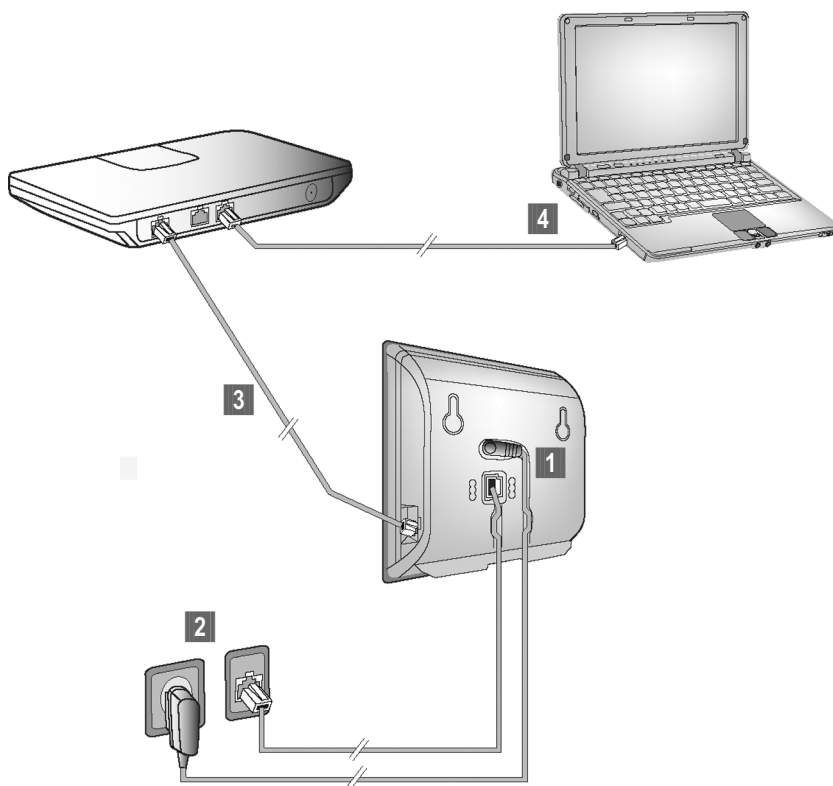
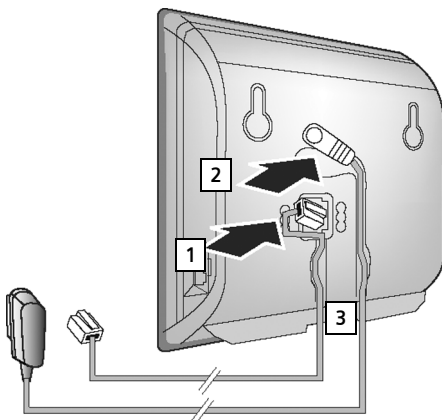

Figure 1 Connecting the phone to the fixed line network and the Internet

Follow the steps in the order given below:

- 1** Connect the phone cord and power lead to the base station.
- 2** Connect the base station to the fixed line network and the electrical power supply.
- 3** To connect the base station to the Internet, first connect the base station to the router (connection via router and modem or via router with integrated modem).
- 4** Connect the PC and router (optional) – for advanced configuration of the base station (→ [Page 144](#)).

1. Connect the phone cord and power lead to the base station



- 1** Insert the phone cord into the lower connection socket at the rear of the base station.
- 2** Insert the power lead of the power adapter into the upper connection socket at the rear of the base station.
- 3** Push both cables into the appropriate cable channels.

First steps

2. Connect the base station to the fixed line network and the electrical power supply

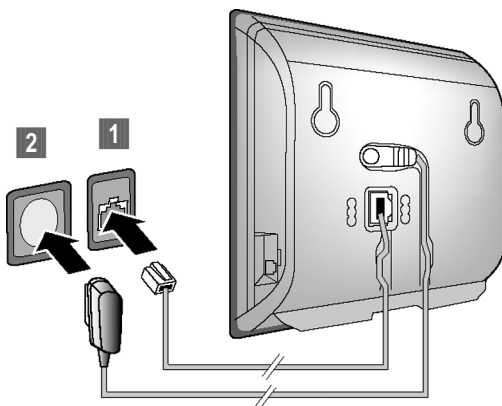

- 1 Insert the phone cord into the fixed line network connection socket.
- 2 **Then** insert the power adapter into the electrical socket.

Warning

- ◆ Keep the power adapter **plugged in at all times** for operation, as the phone does not work without an electrical power connection.
 - ◆ Use only the power adapter and phone cord **supplied**. Pin connections on telephone cords can vary (pin connections → [Page 202](#)).
-

You can now use your phone to make calls via the fixed line network and can be reached on your fixed line number.

By default, the answering machine is switched on in answer and record mode with a pre-recorded announcement (→ [Page 96](#)).

3. Connect the base station to the router (Internet)

For Internet access you need a router connected to the Internet via a modem (this may be integrated in the router).

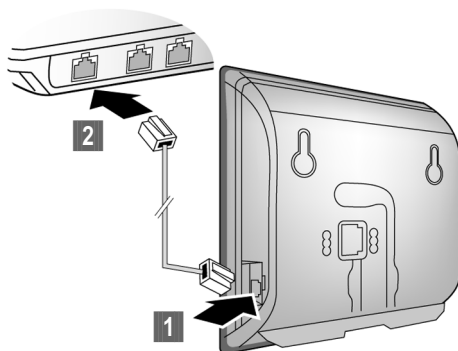

- 1** Connect an Ethernet cable plug into the LAN port at the side of the base station.
- 2** Then insert the other end of the Ethernet cable plug into a LAN port on the router.

As soon as the cable connecting the phone and router is plugged in and the router is activated, the key lights up on the front of the base station (Paging key).

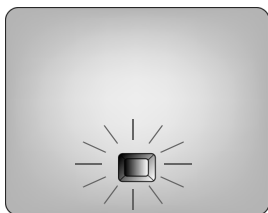

You are now ready to establish VoIP connections within Gigaset.net (→ [Page 54](#)).

First steps

Making settings for VoIP telephony

Before you can use the Internet (VoIP) to phone any other numbers on the Internet, the fixed line network or the cellular phone network, you need the services of a VoIP provider who supports the VoIP SIP standard.

Prerequisite: You have registered with such a VoIP provider (e.g. via your PC) and set up at least one VoIP account.

To use VoIP, you need to enter the access data for your VoIP account. You will receive all the necessary data from your VoIP provider. This will include:

- ◆ Your user name (if requested by the VoIP provider) is the user identification (Caller ID) for your account, which is often identical to your phone number
- ◆ Your authentication name or login ID
- ◆ The (login) password registered with the VoIP provider
- ◆ General settings for your VoIP provider (server addresses, etc.)

Your phone connection assistant can help you make these entries.

Automatic configuration:

If your provider supports "automatic configuration", you will receive an "auto-configuration code" from your provider instead of an authentication name and password.

Configure VoIP using the auto-configuration code via the base station Web configurator.

Starting the connection assistant

Prerequisite: The base station is connected to the electrical power supply and a router. Your router is connected to the Internet (→ [Page 23](#)).

— Please note —

Your phone is preconfigured for dynamic assignment of the IP address. In order for your router to "recognize" the phone, dynamic IP address assignment must also be activated on the router, i.e. the router's DHCP server must be activated.

If the DHCP server cannot or should not be activated, you must first assign a fixed IP address to the phone. For further information, see [Page 139](#).



As soon as the handset battery is sufficiently charged, the Message key (envelope icon) on the handset will flash (approx. 20 minutes after you have put the handset in the charging cradle).

▶ Press the Message key (envelope icon).





You will see the following display.

- ▶ Press the key below **Yes** on the display screen.

You are prompted to enter your phone's system PIN.

New firmware available appears in the display.

New/improved firmware is available for your phone on the Internet. First perform an automatic update of the firmware (→ [Page 136](#)). Once the update has been completed (after approx. 3 minutes) the handset's idle display appears again and the Message key  flashes. If you press , the display shown in the picture above appears and you can start the connection assistant.

Please note

To protect your phone and its system settings from unauthorized access, please define a 4-digit number code (system PIN) known only to yourself. This code must be entered before you can register/de-register handsets or alter your phone's VoIP or LAN settings.

The default system PIN is 0000 (4 x zero). For further information, see [Page 132](#).



The active line is marked [----].

- ▶ Enter your phone's current system PIN using the keypad.
- ▶ Press the key below **OK** on the display screen.

The connection assistant is launched.

First steps

Please note

- ◆ You can also call up the connection assistant at any time via the menu (→ [Page 137](#)).
- ◆ The connection assistant will also start automatically if you try to establish a connection via the Internet before you have made the necessary settings.
Prerequisite: You have **not** activated the fixed line network connection as a replacement connection (→ [Page 168](#)):

Downloading VoIP provider data

The connection assistant establishes a connection with the Gigaset configuration server on the Internet. Various profiles with general access data for different VoIP providers can be downloaded here.

After a brief period you will see the following display:



A list of countries is loaded.

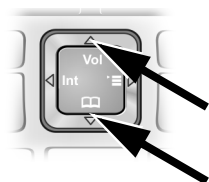

- ▶ Press up or down on the Control key repeatedly ...



... until the country in which you are using the phone is marked on the display.

- ▶ Press the key below **OK** on the display screen to confirm your selection.

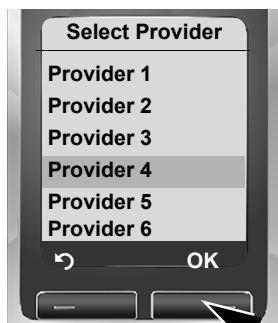
First steps

A list is displayed of the VoIP providers for which a profile is available on the configuration server with the general access data.

- ▶ Press the top or bottom of the Control key  repeatedly until your VoIP provider appears on the display.
- ▶ Press the key below **OK** on the display screen to confirm your selection.

The general access data for your VoIP provider is be downloaded and saved on the phone.

Please note

If the data for your VoIP provider is not available for downloading, press the  Display key twice. You can then carry out the following steps with the connection assistant.

You must then make the settings needed for the VoIP provider using the Web configurator (→ [Page 156](#)).

Your VoIP provider will supply you with this data.

Entering user data for your first VoIP account

You will now be prompted to enter your personal access data for your VoIP accounts.

The following are provider-dependent:



- ◆ Username, User Name , Authent. Password

Or:

- ◆ User Name , Authent. Password

Please note

When entering case sensitive access data:

- ◆ To switch between upper and lower case and digits, press the  key (several times if necessary). You can see briefly in the display whether upper case, lower case or digits is selected.
- ◆ Characters entered incorrectly can be deleted using the left Display key below . The character to the left of the cursor is deleted.
- ◆ You can navigate within the input field using the Control key  (press left/right).

First steps



If your VoIP provider does not require a user name, skip this step.

- ▶ Using the keypad, enter the user name that you received from your VoIP provider.
- ▶ Press the key below **OK** on the display screen.



- ▶ Using the keypad, enter the authentication name that you received from your VoIP provider.
- ▶ Press the key below **OK** on the display screen.

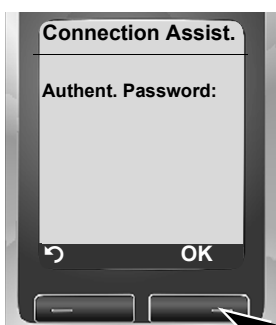

- ▶ Use the keypad to enter your password.
- ▶ Press the key below **OK** on the display screen.

When you have made all the necessary settings the "Connection data complete" message appears on the display.

Completing the VoIP settings

After the entries have been completed, the handset reverts to idle status.

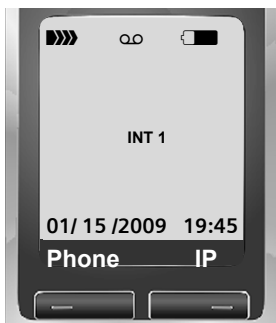

- ▶ Test whether your VoIP data is complete and has been stored in the phone correctly.

Calling via VoIP:

Enter a number using the handset keypad and press and **hold** the Talk key .

If a VoIP connection cannot be established, a corresponding message is shown in the display.

You can now use your phone to make calls via the fixed line network and the Internet! Callers can reach you on your fixed line number and your VoIP number.

Please note

- ◆ To ensure that you can always be reached via the Internet, the router must be permanently connected to the Internet.
 - ◆ If you have started the connection assistant via the menu, once the entries are completed, press and hold the End Call key  to return the handset to idle status.
 - ◆ If you try to make a call via a VoIP connection that is not configured correctly, the following VoIP status message will appear in the display: **IP configuration error: xxx** (xxx = VoIP status code). The various status codes and their respective meanings are listed on [Page 194](#).
-

Please note

You can enter five additional VoIP accounts (VoIP phone numbers) via the Web configurator later (→ [Page 154](#)). Including your fixed line network number, your phone can then be reached via up to seven different phone numbers. You can assign the phone numbers to the individual handsets that are registered with the base station as send and receive numbers (→ [Page 168](#)).

First steps

Icons on the idle display

The following is displayed:

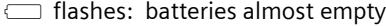
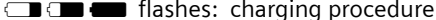
- ◆ The internal number, e.g. INT 1.
- ◆ The quality of the reception signal between the base station and the handset:
 - poor to good: ▬▬▬ ▬▬▬ ▬▬▬ ▬▬▬
 - no reception: ▬▬▬ flashes
- ◆ Battery charge status:
 -  (empty to full)
 -  flashes: batteries almost empty
 -  flashes: charging procedure

No connection to the Internet/VoIP server

If one of the following messages is displayed instead of the internal name after the connection assistant is closed, errors have occurred:

- ◆ **Server not accessible**
- ◆ **Provider registration failed**



Below you will find possible causes and measures you can take.

Server not accessible

The phone has no connection to the Internet.

- ▶ Check the cable connections between the base station and the router (the LED on the base station must light up) and the connection between the router and the Internet connection.
- ▶ Verify that the phone is connected to the LAN.
 - It may not have been possible to dynamically assign an IP address to the phone
- or
 - You have assigned a static IP address to the phone that has either already been assigned to another LAN subscriber or does not belong to the router's address block.
- ▶ Press the Paging key on the base station. The IP address appears on the handset display.
- ▶ Press the Talk key on the handset to end paging call.
- ▶ Start the Web configurator with the IP address.
- ▶ If no connection can be established, change the settings on the router (activate DHCP server) or the phone's IP address.

Provider registration failed

- ◆ Your personal data for registering with the VoIP provider may have been entered incompletely or incorrectly.
 - ▶ Check your entries for **Username**, **User Name** and **Authent. Password**. Particularly check your use of upper and lower case.
To do this, open the following menu on your handset:  → 
 - **Telephony** → **VoIP** (enter system PIN) → **Provider Registr.**
 - (→ [Page 138](#))
- ◆ The server address for the VoIP server has not yet been entered, or has been entered incorrectly.
 - ▶ Start the Web configurator.
 - ▶ Open the following Web page: **Settings** → **Telephony** → **Connections**.
 - ▶ Click the **Edit** button next to the first VoIP connection.
 - ▶ Edit the server address where necessary.

Please note

If port forwarding is activated on your router for the ports (→ [Page 177](#)) that have been registered as the SIP and RTP ports, we recommend to deactivate DHCP and assign the phone a static IP address (otherwise you may not be able to hear the other party during VoIP calls):

- ◆ Assign an IP address via the handset menu:

 →  → **Base** → **Local Network**

Or

- ◆ Assign an IP address via the Web configurator:
 - ▶ Open the following Web page: **Settings** → **IP Configuration**.
 - ▶ Select **IP address type**.

Please note that the IP address and subnet mask depend on the router's address block.

You must also enter the default gateway and DNS server. The IP address for the router is generally entered here.

First steps

Attaching the belt clip and headset

By using a belt clip and headset (optional), you can easily make your handset a constant companion both inside the building and in its immediate vicinity.

Attaching the belt clip

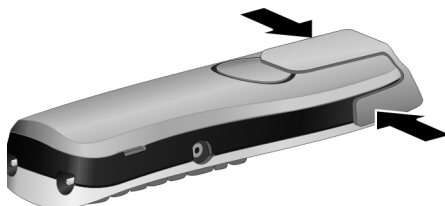

There are notches for attaching the belt clip on the side of the handset at approximately the same height as the display.

- ▶ Press the belt clip on the back of the handset so that the lugs of the belt clip click into place in the notches.

Connection socket for headset

You can connect various types of headset, including the HAMA, Plantronics M40, MX100 and MX150 (with a 2.5 mm jack connector).

You can find a list of compatible headsets on the Internet at:

www.plantronics.com/productfinder

What would you like to do next?

Now you have successfully started your phone, you will probably want to adapt it to your personal requirements. Use the following guide to quickly locate the most important subjects.

If you are unfamiliar with menu-driven devices such as other Gigaset telephones first read the section "[Operating the handset](#)" → [Page 34](#).

Information on is located here.
Making calls via VoIP or the fixed line network	Page 45
Setting the ringer melody and volume	Page 127
Setting the handset volume	Page 126
Entering your local area code/extra codes	Page 135
Setting Eco Mode	Page 109
Operating the telephone on a PABX	Page 141
Registering existing handsets to a base station	Page 113
Transferring directory entries from existing Gigaset handsets to the new handset(s)	Page 73
Entering additional VoIP accounts	Page 154

If you have any questions about using your phone, please read the troubleshooting tips in the section "[Questions and answers](#)" (→ [Page 190](#)) or contact our Customer Care team (→ [Page 190](#)).

Operating the handset

Operating the handset





Using the Control key

In this user guide, the side/position of the Control key that you must press in the given operating situation is shown in black (top, bottom, right, left). Example:  for "press the top of the Control key".







The Control key has a number of different functions:

When the handset is in idle status

-  Press briefly to open the handset directory.
Press and hold: open Gigaset.net directory.
-  Open the main menu.
-  Open the list of handsets.
-  Call up the menu for setting the handset's call volume (→ [Page 126](#)), ringers (→ [Page 127](#)) and advisory tones (→ [Page 129](#)).



In the main menu and input fields

Use the Control key to move the cursor **up** , **down** , **right**  or **left** .

In lists and submenus

-  /  Scroll up/down line by line.

During an external call

-  Press briefly to open the handset directory.
-  Initiate an internal call.
-  Adjust the handset volume for earpiece and speaker mode.

Using the Display keys

The function of the Display keys changes depending on the particular operating situation. Each of the current functions is shown in the bottom display line. Example:

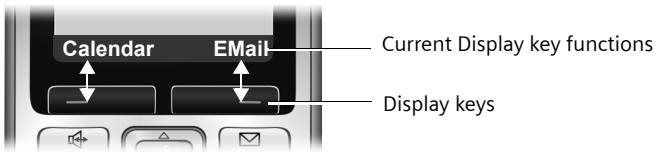

You can define your own Display key functions when the handset is in idle status (→ [Page 124](#)). If a Display key has not yet been given a function, ? is displayed above the key.

Important Display key functions include:

Options	Open a situation-dependent menu (context menu).
OK	Confirm selection.
Save	Store entry.
<C	Delete key: deletes one character at a time from right to left.
↶	Go back one menu level or cancel operation.
→☒	Copy number to directory.
☎	Forward external call to answering machine.

Using the keys on the keypad

/ / , etc.
Press the matching key on the handset.

Enter digits or letters.

Correcting text entry errors

You can correct incorrect characters in input fields by navigating to the incorrect entry using the Control key. You can then:

- ◆ Use the Display key **<C** to delete the character to the left of the cursor.
- ◆ Insert new characters to the left of the cursor.
- ◆ Overwrite the highlighted flashing character, e.g. when entering date and time or IP addresses.

Operating the handset

Using the menus



Your telephone's functions are accessed using a menu that has a number of levels.



Main menu (first menu level)

- ▶ When the handset is in idle status, press the Control key  to open the main menu.

The main menu functions are shown on the display with icons. The icon for the selected function is shown enlarged, and the name of the associated function appears in the display's heading.

Access a function, i.e. open the corresponding sub-menu (next menu level):

- ▶ Use the /  Control key to navigate to the function and press the **OK** Display key.

To return to idle status, briefly press the Display key  or the End Call key .

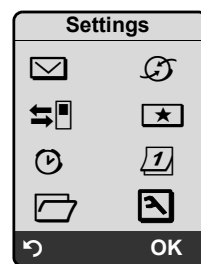

Submenus

The functions in the submenus are displayed as lists.

To access a function:

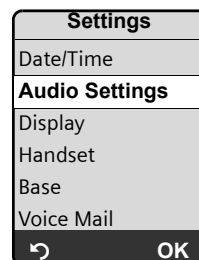

- ▶ Use the Control key  to scroll to the desired function. The function is selected if it is marked with a bar and shown in bold. Press the Display key **OK** to confirm your selection and open the next menu level if necessary.



This operating step is illustrated below:

Audio Settings

Select and press **OK**.

To return to the previous menu level or cancel the operation, briefly press the Display key  or the End Call key .

Reverting to idle status

You can revert to idle status from anywhere in the menu as follows:

- ▶ Press and **hold** the End Call key .

Or:

- ▶ Do not press any key: after 2 minutes the display will **automatically** revert to idle status.

Changes that you have not confirmed or saved by pressing **OK**, **Yes**, **Save**, **Send** or **Save Entry** **OK** are lost.

An example of the display in idle status is shown on [Page 1](#).

Activating/deactivating the handset



With the phone in idle status, press and **hold** the End Call key to deactivate the handset. You will hear the confirmation tone.

Press and **hold** the End Call key again to reactivate the handset.

Activating/deactivating the keypad lock

The keypad lock prevents any inadvertent use of the phone.



Press and **hold** the Pound key (#). You will hear the confirmation tone.

When the keypad lock is activated, you will see the icon  on the display.

The keypad lock is deactivated automatically during an incoming call, and is then reactivated.

Please note

If you inadvertently press a key while the keypad lock is activated, an advisory message appears on the display. To deactivate the keypad lock, press and **hold** the Pound key (.

Using this guide

The operating steps are shown in abbreviated form in the user guide.

Example of "Activating/deactivating auto answer":

The display



→  → Handset → Auto Answer ( = on)

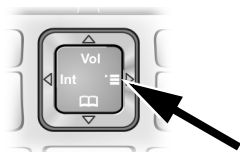

Operating the handset

means:



- ▶ When the handset is in idle status, press the right of the Control key  to open the main menu.



- ▶ Use the Control key to select the icon . For example, press once on the left of the Control key . **Settings** is shown in the heading.



- ▶ To open the submenu, press the right Display key **OK**.

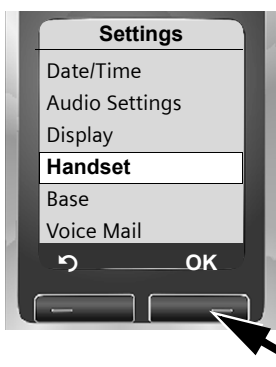

- ▶ Press the bottom of the Control key  repeatedly until the menu item **Handset** is selected.

- ▶ To open the submenu, press the right Display key **OK**.

Operating the handset



- ▶ Press the bottom of the Control key  repeatedly until the menu item **Auto Answer** is selected.

The icon after **Auto Answer** tells you whether auto answer is currently activated or deactivated:

= on

= off

- ▶ To change the setting, press the right Display key **OK**.



- ▶ Press and hold the End Call key  to return the handset to idle status.

Menu trees

Menu trees



Phone menu

Open the main menu on your phone by clicking on the right of the Control key when the handset is in idle status: .



There are two ways to select a function:

Using number combinations ("shortcut")

- ▶ Enter the number combination that is in front of the function in the menu tree.

Example:     for "Set handset language".

Scrolling through the menus

- ▶ In the main menu: using the Control key   (press top/bottom or left/right), navigate to the function and press **OK**.
- ▶ In the submenu: using the Control key  (press top/bottom), scroll to the function and press **OK**.

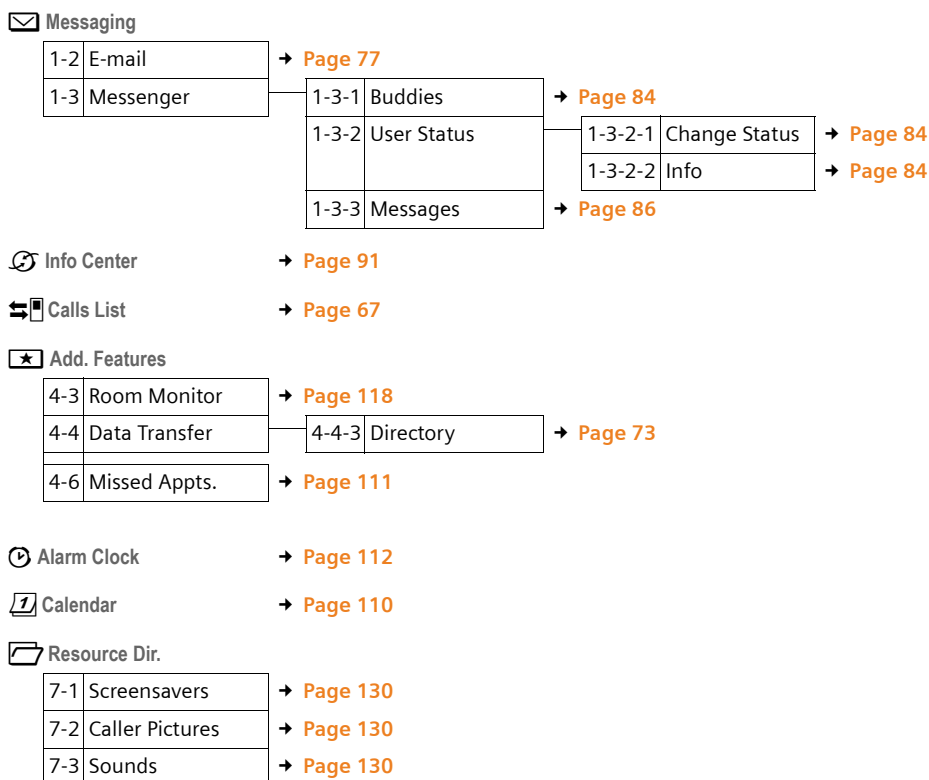

 Settings

8-1	Date/Time			→ Page 16		
8-2	Audio Settings	8-2-1	Handset Volume			
		8-2-2	Ringer Settings	8-2-2-1	Ext. Calls	→ Page 127
				8-2-2-2	Internal Calls	
				8-2-2-3	Appointments	
8-2-2-4	All					
		8-2-3	Advisory Tones	→ Page 129		
8-3	Display	8-3-1	Screen Saver	→ Page 122		
		8-3-2	Color Scheme	→ Page 122		
		8-3-3	Contrast	→ Page 122		
		8-3-4	Backlight	→ Page 123		
8-4	Handset	8-4-1	Language	→ Page 121		
		8-4-2	Auto Answer	→ Page 126		
		8-4-3	Register H/Set	→ Page 113		
		8-4-4	Select Base	→ Page 115		
		8-4-5	Area Codes	→ Page 131		
		8-4-6	Reset Handset	→ Page 131		
8-5	Base	8-5-1	Calls List Type	8-5-1-1	Missed Calls	→ Page 67
				8-5-1-2	All Calls	
		8-5-2	Music on hold	→ Page 134		
		8-5-3	System PIN	→ Page 132		
		8-5-4	Base Reset	→ Page 133		
		8-5-5	Add. Features	8-5-5-4	Access Code	→ Page 142
				8-5-5-5	Eco Mode	→ Page 109
		8-5-6	Local Network	→ Page 139		
8-5-8	Software Update	→ Page 136				

Menu trees

8-6	Voice Mail	8-6-1	Local AM	8-6-1-1	Ans Machine	→ Page 97
				8-6-1-2	Call Screening	→ Page 102
				8-6-1-3	Announcements	→ Page 98
				8-6-1-4	Message Length	→ Page 103
				8-6-1-5	Record Quality	→ Page 103
				8-6-1-6	Ring Delay	→ Page 103
		8-6-2	Network AM(s)	8-6-2-1	Net AM Fixed Ln.	→ Page 106
				8-6-2-2	Net AM IP1	
				:		(dependent on the number of configured VoIP phone numbers and receive numbers on the handset)
		8-6-2-7	Net AM IP6			
		8-6-3	Set Key 1	Local AM		→ Page 104
				Net AM Fixed Ln.		
				Net AM IP1		
				:		(dependent on the number of configured VoIP phone numbers and receive numbers on the handset)
				Net AM IP6		

Menu trees

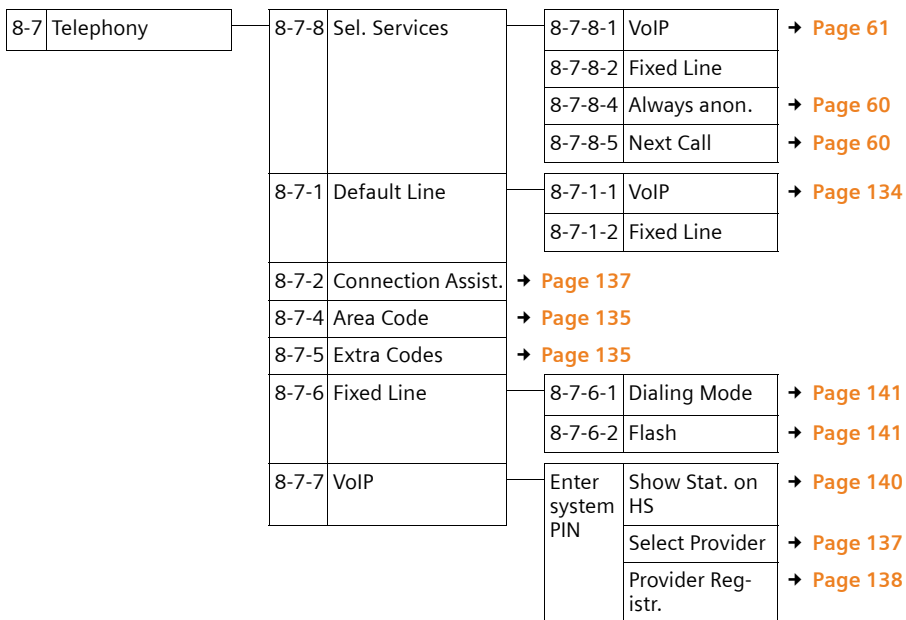

Menu trees

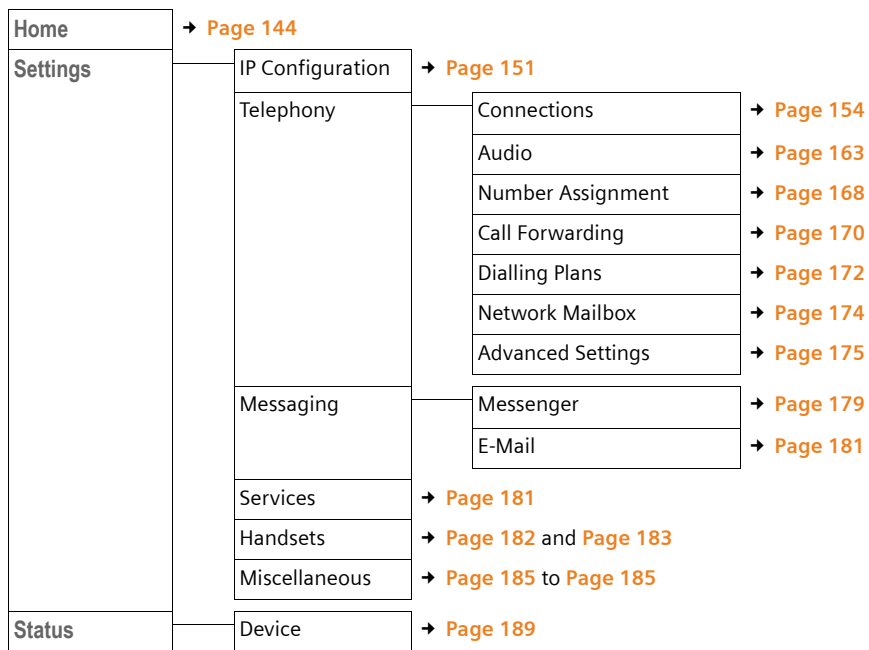

Web configurator menu



Making calls with VoIP and the fixed line network

Making an external call

External calls are calls made via the public telephone network (fixed line network) or via the Internet (VoIP). You decide which connection you want to use for a specific call when you dial the number. You have the following options:

- ◆ Select the connection type with the Talk key  (briefly press/press and hold  →, → [Page 45](#)).
- ◆ Select the connection type via the Display keys by assigning VoIP and/or the fixed line network to your Display key, → [Page 46](#)
- ◆ Select a special connection via your line suffix, → [Page 47](#)

Please note

- ◆ You can conduct three separate external calls via your base station (using different handsets): two calls via VoIP and one via the fixed line network.
- ◆ During an external call, you can see from the color scheme of the display whether you are connected to the other party via VoIP or the fixed line network. When you make or receive a call on the fixed line network, the display color changes to orange.
- ◆ You can define dialing plans for certain numbers or area codes by determining the connection and therefore the billing method to be used (cost control → [Page 172](#)) when these numbers are dialed.
- ◆ Dialing with the Directory (→ [Page 70](#)), Quick dial (→ [Page 124](#)) or Last Number Redial list (→ [Page 65](#)) saves repeated keying of phone numbers. You can modify or add to these numbers on a call by call basis.
- ◆ If you use VoIP to make a call to the fixed line network, you may also have to dial your local area code for local calls (depending on the VoIP provider). You can avoid having to dial your own area code by entering it into the configuration (→ → [Page 135](#), [Page 171](#)) and activating the option **Predial area code for local calls through VoIP** (→ [Page 171](#)).
- ◆ Depending on the exchange, you may not have to dial your own area code when making local calls via the fixed line network.

Use the Talk key to select the type of connection and make the call

By briefly pressing or pressing and holding the Talk key , you can determine the type of connection for the call you want to make (fixed line network or VoIP).



Prerequisite: You enter the number without a line suffix (→ [Page 47](#)) and have not defined any dialing plans for this number.



Enter number (without suffix) and **briefly press/press and hold** the Talk key.

Making calls with VoIP and the fixed line network

A default connection is established on your phone (fixed line network or VoIP → [Page 134/Page 167](#)).

- ▶ **Briefly** press the Talk key  to make a call via this default connection.
- ▶ Press and **hold** the Talk key  to make the call via the other connection type.

If you have assigned a number of VoIP numbers to your phone, you can define which VoIP number (VoIP account) is used for external calls from each specific handset (handset send number, → [Page 168](#)).

Please note

- ◆ If you are using a GAP-compatible handset other than the Gigaset handsets A58H, S67H, S68H, SL37H, S45 and C45, every call is made via the standard connection, even if you press and hold the Talk key.
 - ◆ If you have activated the option **Automatic Fallback to Fixed Line** with the Web configurator (→ [Page 168](#)):
If the attempt to establish a connection fails, an attempt is made automatically to establish the connection via the fixed line network.
-

Selecting and dialing a connection type via your Display keys

Prerequisite: **Phone** and/or **IP** are assigned to the Display keys on your handset (→ [Page 124](#)).

Phone / **IP**

Press the Display key to select the connection type.



Enter number or select from directory.

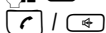

Press the Talk or Speaker key.

The number is always dialed via the selected connection type.

Exception:

If you have activated the option "**Automatic Fallback to Fixed Line**" (Web configurator, → [Page 168](#)) and the attempt to establish a connection via VoIP fails, an attempt is made automatically to establish the connection via the fixed line network.

Please note

If you have pressed the Display key **IP** before dialing and ...

- ◆ Dialed the number with suffix #1 to #6, your call is made via the VoIP account assigned to the suffix. The number will not be dialed if the suffix is invalid (e.g. no VoIP connection assigned).
- ◆ Dialed the number without a suffix or with the suffix #0, your call is made via the handset's VoIP send number.

Do not enter a suffix if you have pressed the Display key **Phone** prior to dialing. Otherwise the suffix is dialed together with the number via the fixed line network. This may cause errors!

Making calls with VoIP and the fixed line network

Select and dial a connection via your line suffix

You can configure up to six VoIP numbers on your phone in addition to the fixed line network number and the Gigaset.net number. A (line) suffix is assigned to each number (line) of your phone:

- ◆ The fixed line network number has the suffix #0
- ◆ VoIP numbers have the suffixes #1 to #6 (→ [Page 155](#))
- ◆ And the Gigaset.net number has the suffix #9

When dialing, you can use this line suffix to specify the connection via which you would like to call or be charged.



Enter the number of the party you wish to call.



Add the suffix of the connection (your phone number) from which the call is to be made and charged to.



Press the Talk key.

The connection is always made via the line with the assigned suffix, regardless of whether you press the Talk key  **briefly** or press and **hold**.

Example



If you enter the number 1234567890#1 and press the Talk key , the number 1234567890 is dialed via the first VoIP connection in the configuration.

Please note

- ◆ If you specify a suffix for which no VoIP connection is configured in your base station, the VoIP status code 0x33 is displayed. The number will not be dialed.
 - ◆ If you have activated the option **Automatic Fallback to Fixed Line** with the Web configurator (→ [Page 168](#)):
If the attempt to establish a connection fails, an attempt is made automatically to establish the connection via the fixed line network.
-

Entering an IP address (provider-dependent)

You can also dial an IP address instead of a phone number using VoIP.

- ▶ Press the Asterisk key  to separate the sections of the IP address (e.g. 149*246*122*28).
- ▶ If necessary press the Pound  key to attach the SIP port number of the person you are calling to the IP address (e.g. 149*246*122*28#5060).

You **cannot** dial IP addresses using a line suffix.

If your VoIP provider does not support the choice of IP addresses, each part of the address is interpreted as a normal phone number.

Canceling the dialing operation

You can cancel the dialing operation with the End Call key .

Making calls with VoIP and the fixed line network

Dialing emergency numbers – defining dialing plans

You can use the Web configurator to block certain numbers or to define which of your numbers (fixed line network, VoIP) should be used to call specific numbers (Dialling Plans, → [Page 172](#)).

If you enter a number that has a defined dialing plan, the call is made via the line defined in the dialing plan – regardless of whether the Talk key is pressed briefly or pressed and held. Any automatic area code will **not** be prefixed to the number.

Emergency numbers

Dialing plans for emergency numbers (e.g. the **local** emergency service number) are preset for certain countries. Emergency calls are then always made via the fixed line network.

You cannot delete or deactivate these dialing plans. However, you can change the connection through which each emergency number should be called (e.g. if the phone is not connected to the fixed line network). You must make sure that the VoIP provider for the selected connection supports emergency calls. If the VoIP connection is deleted from the configuration, the emergency call can no longer be made.

If your phone does not have default dialing plans for emergency calls, define the rules yourself (→ [Page 172](#)). Assign them to a connection that you know supports emergency calls. Calls to emergency numbers are always supported by fixed line networks.

Please note

- ◆ If no rules are defined for emergency numbers and you have programmed an automatic local area code (→ [Page 171](#)), the code is prefixed to emergency numbers as soon as they are dialed via a VoIP connection.
 - ◆ Emergency numbers cannot be dialed if the keypad lock is activated. Before dialing, press **and hold** the Pound key , to release the keypad lock.
-

Ending a call



Press the End Call key.

Accepting a call



The handset indicates an incoming call in three ways: by ringing, by a display on the screen and by the flashing Speaker key .

Please note

Only calls to receive numbers assigned to your handset are signaled (→ [Page 168](#)). The following conditions apply in particular:

- ◆ If a phone number is assigned to neither a handset nor the answering machine as a receive number, calls to this number are signaled on all handsets.
 - ◆ If the phone number is not assigned to a handset but is assigned to the answering machine, the call will not be signaled on any handset and the answering machine accepts the call.
 - ◆ If you have not assigned receive numbers to any of the registered handsets or the answering machine, calls to all connections are signaled on all handsets.
 - ◆ Calls to your IP address are signaled on all handsets.
-

You can accept the call by:

- ▶ Pressing the Talk key .
- ▶ Pressing the Speaker key .
- ▶ Pressing the Display key  to forward the call to the answering machine (→ [Page 101](#)).

If the handset is in the charging cradle and the **Auto Answer** function is activated (→ [Page 126](#)), the handset will take a call automatically when you lift it out of the cradle.

If the ringer is intrusive, press the Display key **Silence**. You can accept the call as long as it is displayed on the screen.

Please note

You can reject VoIP calls by pressing the End Call key . The caller receives an appropriate message (provider-dependent).

In the case of fixed line network calls, pressing the End Call key deactivates the ringer (like **Silence**).

Caller ID

When you receive a call from the Internet, the caller's number or the name they have specified is displayed on the screen.

When you receive a call from the fixed line network, the caller's number and/or name is displayed on the screen if you have requested CID from your network provider.

If the phone number is identified and the caller's number is saved in your handset's local directory, the name is displayed from the directory. A CID image assigned to the name will also appear in the display.

Making calls with VoIP and the fixed line network

Call display

You can use the display to determine whether the call is for your fixed line network number or one of your VoIP numbers.

Calls to your fixed line number

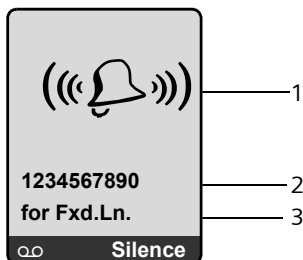

- 1 Ringer icon or the clip image assigned to the caller (→ [Page 71](#))
- 2 Number or name of the caller
- 3 Display of the receive number: the name that you have assigned to your fixed line network number is displayed (→ [Page 162](#)).

Calls to your VoIP number

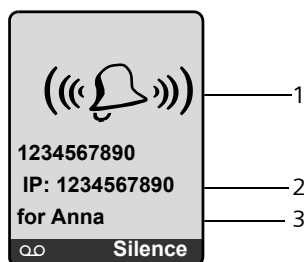

- 1 Ringer icon or the clip image assigned to the caller (→ [Page 71](#))
- 2 Number or name of the caller
- 3 Receive number: indicates which of your VoIP phone numbers the caller has dialed. You assign the name when you enter the VoIP numbers in the phone (→ [Page 156](#)). For calls from Gigaset.net, for Gigaset.net is displayed.

Display when Caller ID is suppressed

The number or name of the caller is not displayed if the caller has suppressed Caller ID:

- ◆ VoIP: The caller has activated the "anonymous calling" function.
- ◆ Fixed line network: The caller has activated the "anonymous calling" function, or has suppressed Caller ID from his fixed line network provider.

Making calls with VoIP and the fixed line network

The following is displayed in place of the number:

- ◆ With a call to one of your VoIP phone numbers, the display is provider-dependent.

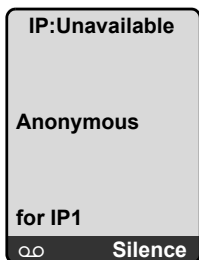

or

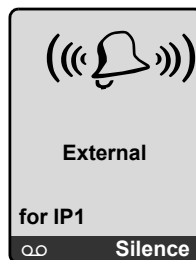

- ◆ For a call to your fixed line network numbers:
 - If no number is transmitted:

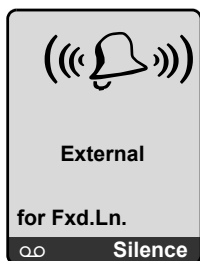

- If the caller has blocked Caller ID:



- If the caller has not arranged Caller ID:



Making calls with VoIP and the fixed line network

Screen display with CNIP (fixed line network)

Prerequisite: Call is made from a fixed line network connection to your fixed line network number.

If you have CNIP, then the name (town/city) that is registered with your network provider for the caller's number will **also** be displayed. If the caller's number is stored in your directory then the directory entry is shown.

The display shows:

- ◆ **External** if no number is transmitted.
- ◆ **Withheld**, if the caller has suppressed Caller ID.
- ◆ **Unavailable**, if the caller has not arranged Caller ID.

VoIP: Displaying the called party's phone number (COLP)

Prerequisites:

- ◆ Your VoIP provider supports COLP (**C**onnect**e**d Line Identification Presentation). You may have to ask your provider to activate COLP (contact your VoIP provider for more information).
- ◆ The called party has not activated COLR (**C**onnect**e**d Line Identification Restriction).

For outgoing VoIP calls, the phone number of the connection on which the call is received is displayed on the handset.

The displayed number may differ from the number you have dialed. Examples:

- ◆ The called party has activated call forwarding.
- ◆ The call is answered by another connection within a PABX system.

If there is an entry in the directory for this phone number, the corresponding name is displayed.

Please note

- ◆ The number of the connection you have reached (or the assigned name) will also be displayed instead of the called number during call swap, conference calls and consultation calls.
 - ◆ When the phone number is copied to the directory (**Options** → **Copy to directory**) and the Last Number Redial list, the dialed number (not the displayed number) is copied.
-

Using speaker mode

In speaker mode, instead of holding the handset to your ear you can put it down, for example on the table in front of you. This allows others to participate in the call.

Activating/deactivating speaker mode

Activating while dialing



Enter number and **briefly press/press and hold** the Speaker key to select the connection type (→ [Page 45](#)).

- ▶ Inform your caller before you use the speaker function so that they know someone else is listening.

Switching between earpiece and speaker mode

- ▶ Press the Speaker key to activate or deactivate the speaker during a call and when listening to the answering machine.

If you wish to place the handset in the charging cradle during a call:

- ▶ Press and hold the Speaker key while placing the handset in the charging cradle.
- ▶ If the Speaker key does not light up, press the key again.

For instructions on adjusting the handset volume, see → [Page 126](#).

Deactivating your handset's microphone

You can deactivate your handset's microphone during an external call (including during a conference call or when call swapping). The other party can no longer hear you, but you can still hear them.

Deactivating the microphone



Press the Display key to deactivate the handset. Your handset's microphone is deactivated. The display shows **Microphone is off**.

Reactivating the microphone



Press the Display key to reactivate the microphone.

Please note

Under the following circumstances, the microphone is **automatically reactivated**:

- ◆ If, during an external call (you have deactivated the microphone), you establish a second connection, either by accepting a waiting call or by successfully connecting to an external/internal consultation call, the microphone is activated. If you go back to the first party, the microphone remains **activated**.
(If you reject a waiting call or are unable to connect to a consultation call, the microphone remains deactivated.)
 - ◆ If you have deactivated the microphone during call swapping, it is reactivated for both connections as soon as you swap to the other party.
 - ◆ If you have deactivated the microphone during a conference call, the microphone is reactivated when you end the conference call by pressing **Options** → **End Conference** (call swap).
-

VoIP telephony via Gigaset.net

Muting the handset

You can mute your handset during an external call. The other party can no longer hear you, Likewise, you can no longer hear the other party. The other party will hear music on hold, if activated (→ [Page 134](#)).

Muting the handset

 Press left on the Control key to mute the handset.

Canceling muting

 /  Press the Display or End Call key to cancel the muting.

VoIP telephony via Gigaset.net

You can use **Gigaset.net** to make free phone calls via the Internet **directly** to other Gigaset.net users, without having to set up an account with a VoIP provider or make any further settings. You simply have to connect your phone to the power supply and the Internet connection and, if necessary, enter yourself in the Gigaset.net online directory under a name of your choice (→ [Page 55/ Page 58](#)).

Gigaset.net is a VoIP service provided by Gigaset Communications GmbH* to which all users of a Gigaset VoIP device can subscribe.

You can call other subscribers to Gigaset.net **free of charge**, i.e. there are no telephone charges other than the costs for your Internet connection. Connections to/from other networks are not possible.

Please note

Gigaset.net supports broadband telephony: Gigaset.net calls that you make from your Gigaset S675 IP (base station and handset) with another broadband-capable terminal have excellent sound quality.

Every Gigaset VoIP device is assigned a Gigaset.net phone number by default (→ [Page 197](#)).

All registered subscribers are included in the Gigaset.net directory, which you are able to access.

An echo service is available on the phone number **12341#9** (English), **12344#9** (French) or **12346#9** (Spanish) for you to check your VoIP connection.

After an announcement, the echo service sends back the voice data you have received immediately in the form of an echo.

Exclusion of liability

Gigaset.net is a voluntary service provided by Gigaset Communications GmbH with no liability for or guarantee of network availability. This service can be terminated at any time with a notice period of three months.

* Gigaset Communications GmbH is a trademark licensee of Siemens AG

Please note

If you do not use your Gigaset.net connection for six weeks, it is automatically deactivated. You cannot be reached for calls from Gigaset.net.

The connection is reactivated:



- ◆ As soon as you start a search in the Gigaset.net directory or
- ◆ Make a call via Gigaset.net (dial a number with #9 at the end) or
- ◆ Activate the connection via the Web configurator (→ [Page 163](#)).

Opening the Gigaset.net directory

Your handset is in idle status.

 Press and **hold**.

Or:

- ▶ Open the directory with the  button.
- ▶ Select **Gigaset.net** from the directory and press the Talk key . A connection to the Gigaset.net directory is established.

Please note

- ◆ The directory entry **Gigaset.net** is transferred to the handset when it is registered with the base station, if the handset can send and receive directory entries.
- ◆ Calls to the Gigaset.net directory are always **free of charge**.
- ◆ You can also open the Gigaset.net directory by dialing **1188#9** (phone number of the Gigaset.net directory) and pressing the Talk key .

If a connection cannot be made to the Gigaset.net directory, a corresponding message is sent and the handset will go into idle status.

After opening the Gigaset.net directory for the first time

When opening the Gigaset.net directory for the first time you can use the Gigaset.net assistant to create an entry in the Gigaset.net directory for your phone.

The following appears on the handset display:

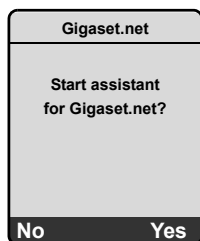

- ▶ Press the Display key **Yes** to start the assistant.

VoIP telephony via Gigaset.net

Please note

If you press **No** the assistant is canceled and will no longer be started. You must then create your entry as described on [Page 58](#).



- ▶ Using the keypad, enter the name that you would like to be listed under in the Gigaset.net directory. The name may contain a maximum of 25 characters.
- ▶ Press **OK** on the right Display key.

If there is already an entry under this name, you will receive a message to this effect and you are asked to enter a name again.

If an entry was created successfully in the Gigaset.net directory, the message "Your user name has been added to Gigaset.net." is displayed.

You have not been able to enter a name

If the attempt to create the entry fails you can create it via the Gigaset.net directory (→ [Page 58](#)).

Searching for subscribers in the Gigaset.net directory

Once the connection to the Gigaset.net directory has been established, you are asked to enter a name that you want to search for.

Nickname search:

Enter the name or part of a name (maximum 25 characters).

Options Press the Display key.

Start search Select and press **OK**.

If the search has been successful, a Hit list is displayed of all the names that begin with the specified character string.

Example:

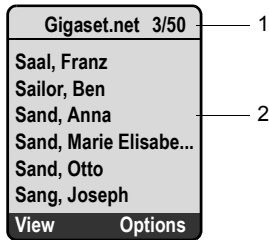

1. 3/50: Entry number/number of hits
2. Name of an entry, abbreviated if necessary

You can scroll through the Hit list with .

If it has **not** been possible to find a **matching** entry, a corresponding message is displayed. You have the following options:

- ▶ Press the Display key **New** to start a new search.



Or

- ▶ Press the Display key **Change** to change the search criteria. The previously entered name is copied and can be edited.

If there are **too many matching** entries in the Gigaset.net directory, the message **Too many entries found** is displayed instead of a Hit list.

- ▶ Press the Display key **Detail** to start a refined search. The previously entered name is copied and can be edited/expanded.

Calling participants

-   Select the subscriber from the Hit list and press the Talk key.

Viewing the subscriber's number

-  Select the subscriber from the Hit list.

- View** Press the Display key.

The display shows the Gigaset.net number and the subscriber's name.

Depending on the length of the information, the name may cross several lines.

Please note

- ◆ Connections to Gigaset.net are always established via the Internet regardless of which default connection is set on your phone. Pressing and holding  or pressing it briefly have no effect.
 - ◆ You can open the Gigaset.net directory and establish connections, even if you have not entered yourself in the Gigaset.net directory.
-

VoIP telephony via Gigaset.net

Using other functions

Prerequisite: The Hit list is displayed.

 (Select entry) → **Options**

The following functions can be selected with :

Copy to directory

Copy the number to the handset directory. The number and name (abbreviated if necessary, maximum 16 characters) are copied to the directory.

▶ Edit and save entry where appropriate (→ [Page 71](#)).

The Hit list is displayed again.

New search

Start a search with a new name (→ [Page 56](#)).

Own details

See "[Managing your own entry](#)" on [Page 58](#).

Please note

If you select a Gigaset.net number from the local directory, the connection is automatically established via Gigaset.net (Internet).

Managing your own entry

You have the following options:

- ◆ Edit the name of your entry in the Gigaset.net directory
- ◆ Delete your entry from the Gigaset.net directory
- ◆ If you did not specify a name when you first opened the Gigaset.net directory (→ [Page 55](#)) or have deleted your name: determine a name and enter it in the directory.

Viewing own entry

You are connected to the Gigaset.net directory:

▶ Select **Options** → **Own details** and press **OK**.

Your Gigaset.net number and, where applicable, your currently entered name are displayed.

Entering/editing a name

Edit Press the Display key.



Edit name or enter new name (maximum 25 characters) and press **OK**.

You can delete the name with **⌫**.

If there is no existing entry with this name in the Gigaset.net directory, the name is saved. A message to this effect is displayed. The handset switches to idle status.

If there is an existing entry with this name, or the entered name contains invalid characters, you are requested to enter a different name.

Please note

If you delete the name, your entry is deleted from the directory. You are no longer "visible" to other Gigaset.net subscribers. However, you can still be reached via your Gigaset.net number. For instructions on displaying the number, see [Page 197](#).

Calling a Gigaset.net subscriber

You can call a Gigaset.net subscriber directly via the Gigaset.net directory (see above) or via their Gigaset.net number :



Enter the Gigaset.net number (including the #9) or select from the handset directory.



Press the Talk key.

Every number ending with #9 is dialed via Gigaset.net.

Making calls via network services

Making calls via network services

Network services are functions made available by your fixed line network or VoIP provider.

Blocking your caller ID – Anonymous calling

Phone number identification can be blocked. Your phone number will not be displayed when making outgoing calls. You are calling anonymously.

Prerequisites:

- ◆ For anonymous calls via your fixed line network connection you need to have requested the relevant service (feature) from your fixed line network provider.
- ◆ Anonymous calls are only possible via VoIP connections through providers that support the "anonymous calling" function. You may have to ask your VoIP provider to activate this function.

Activating/deactivating "anonymous calling" for all calls

Withholding caller ID can be activated/deactivated permanently for all of your phone's connections (fixed line network and VoIP).

When this function is activated, the phone number is withheld both for fixed line network calls and for calls via a VoIP connection. Withholding caller ID is activated for all registered handsets.

 →  → **Telephony** → **Sel. Services**

Always anon.

Select and press **OK** ( = on).

Activating/deactivating "anonymous calling" for the next call

You can change the setting for withholding caller ID for the next call.

 →  → **Telephony** → **Sel. Services** → **Next Call**

Anonymous:

Select **Yes / No** to activate/deactivate withholding caller ID and press **Dial**.



Send

If necessary, enter the phone number with the line suffix.

Press the Display key. The phone number is dialed. If you have not specified a line suffix, the number is dialed via the default connection.

Further network services in the fixed line network

The following network services can only be used for making calls via the fixed line network. You will need to request them from your fixed line network provider.

- ▶ **Contact your network provider for further assistance.**

Functions during a call

Initiating ringback

You will hear the busy tone.

Options → Ringback



Press the End Call key.

Consultation calls

During a call:

Options → External Call



Enter a number or copy it from the directory and press **OK**.

The number is dialed via the fixed line network connection.

Please note

After a few seconds, the number selected for a consultation call is saved in the Last Number Redial list.

◆ Conference call:

- ▶ Talk to both participants: **Options** → Conference.
- ▶ End conference call (call swap): **Options** → End Conference
- ▶ End call with both participants: press the End Call key

Further network services for VoIP

You can use the following network services to make calls via the VoIP connection.

Settings for all calls

General call forwarding

Prerequisite: The VoIP provider supports call forwarding.



→ → Telephony → Sel. Services → VoIP → Call Diversion

The display shows a list of configured and activated VoIP phone numbers and the Gigaset.net number of your telephone. Numbers for which call forwarding is activated are marked with .

- ▶ Select the phone number for which you want to activate or deactivate call forwarding and press **OK**.
- ▶ Change multiple line input:

Making calls via network services

When

Select **All Calls / No Answer / When Busy**.

All Calls: Calls are forwarded immediately, i.e. calls for this VoIP phone number are no longer signaled on your phone.

No Answer: Calls are forwarded if there is no reply within several rings.

When Busy: Calls are forwarded if your line is busy.

Phone

Press the Display key **Edit**. Enter the number to which the call is to be forwarded and press **Save**. You can specify a fixed line network, VoIP or cell phone number for forwarding calls from a VoIP number.

You must specify another Gigaset.net number for call forwarding from your Gigaset.net number.

Status

Activate/deactivate call forwarding.

- ▶ Press the Display key **Save**.

Please note

Forwarding VoIP phone numbers can incur additional costs. Please consult your VoIP provider.

Activating/deactivating call waiting

Prerequisite: Your phone will permit two parallel VoIP connections (→ [Allow 1 VoIP call only on Page 164](#)).

If call waiting is activated, a caller on one of your VoIP connections will hear the ringer if you are already on a call using this VoIP connection. This call is announced sound and visually on your handset screen.

Calls on the fixed line connection are not signaled as call waiting. They are signaled on other registered handsets to which the fixed line number has been assigned as a receive number. If no other handset is available, the caller will hear the busy tone.

Accepting/rejecting a waiting call, → [Page 64](#).

 →  → **Telephony** → **Sel. Services** → **VoIP** → **Call Waiting**

Status Activate/deactivate.

- ▶ Press the Display key **Save**.

Please note

The setting applies to all VoIP phone numbers. It does not affect the procedure for call waiting on the fixed line network.

Functions during a call

Prerequisite: Your phone will permit two parallel VoIP connections (→ [Allow 1 VoIP call only on Page 164](#)).

Consultation calls

During a call:

Options → External Call



Enter number or copy it from the directory and **briefly press/press and hold** the Talk key .

The number must be dialed via VoIP.

Please note

After a few seconds, the number selected for a consultation call is saved in the Last Number Redial list.

If the participant ends the consultation call, press **End** to return to the first call.

If the participant does not answer, press to return to the first call.

If the participant answers, you have the following options:

- ◆ Call swap:
 - ▶ Use to swap between the participants.
 - ▶ End call with active participant: **Options** **End Active Call**.
- ◆ Conference call:
 - ▶ Talk to both participants: **Options** → **Conference**.
 - ▶ End conference call (call swap): **Options** → **End Conference**
 - ▶ End call with both participants: press the End Call key .
- ◆ Transfer (provider-dependent):

Prerequisite:

- You are call swapping and you phoned the currently active participant yourself.
- You are connected to an external participant whom you have called yourself and start an external consultation call.
- ▶ To connect the two external participants:
Options **Call Transfer**

If the call transfer was successful, a message will appear to this effect. The handset will then switch to idle.

If the call transfer was not successful, the party that was previously waiting will call you back automatically.

You can also end the call before the second participant answers.

Please note

You can configure your telephone so that you can also connect the participants together by pressing the key or the End Call key (→ [Page 175](#)).

Making calls via network services

Accepting a waiting call

Prerequisite: Call waiting is activated (→ [Page 62](#)).

Options → Accept Call Wait

You have the option of call swapping or holding a conference call.

Please note

- ◆ If the first call was an internal call, the internal connection is ended.
 - ◆ An internal, waiting call is shown on the display. You can neither accept the internal call nor reject it.
-

Rejecting a waiting call

Options → Reject Call Wait

Using lists

The options are:

- ◆ Last Number Redial list
- ◆ E-mail and Messenger list
- ◆ Calls list
- ◆ Answering Machine list
- ◆ Network mailbox

Using the Last Number Redial list

The Last Number Redial list contains the 20 numbers last dialed with the handset (maximum 32 digits). If one of the numbers is in the directory, the corresponding name is displayed.

Dialing from the Last Number Redial list



Press the key **briefly**.



Select entry.



Briefly press/press and hold the Talk key. The number is dialed using the selected connection type (→ [Page 45](#)).

When a name is displayed, you can display the corresponding phone number by pressing the **View** Display key.

Managing entries in the Last Number Redial list



Press the key **briefly**.



Select entry.

Options

Open menu.

The following functions can be selected with :

Copy to directory

Copy an entry to the directory (→ [Page 74](#)).

Automatic Redial

The number selected is automatically dialed at fixed intervals (at least every 20 seconds). The Speaker key flashes; "open listening" is activated.

- Participant answers: Press Talk key . The function is ended.
- No participant answers: The call is terminated after approx. 30 seconds. The function ends after any key is pressed or after ten failed attempts.

Display Number

(as in the directory, → [Page 72](#))

Delete Entry

Delete selected entry.

Delete List

Delete complete list.

Using lists

Opening lists with the Message key

You can use the Message key  to call the following lists:

- ◆ Answering Machine list
- ◆ Network mailbox, → [Page 106](#)

A separate list is displayed for each network mailbox.

Prerequisite: Its number is saved in the base station, it is switched on (→ [Page 106](#), [Page 174](#)) and the corresponding VoIP/fixed line network number is assigned to the handset as a receive number.



- ◆ Incoming E-mail list, → [Page 77](#)

The list is only displayed if there are new messages in the mailbox on the incoming e-mail server.

- ◆ Calls list
- ◆ Messenger Message list, → [Page 86](#)

The list is only displayed on the handset that is online.

An advisory tone sounds as soon as a **new message** arrives in a list. The  key flashes (it goes off when the key is pressed). In idle status, an icon appears on the display for the new message:

Icon	New message...
	... on one of your network mailboxes or ... in the Answering Machine list
	... in the Calls list
	... in the Messenger or E-mail list

The number of new entries is displayed below the relevant icon.

List selection

If you press the  key, only lists that contain messages are displayed, as well as the lists of network mailboxes **Net AM**

Lists with new messages are displayed first, and are identified in bold. The number of new messages contained in the list is displayed in brackets.

If a list does not contain any new messages, the number of old messages is displayed. Exception: In the case of **Net AM ...** network mailboxes (0) is displayed.

Example:

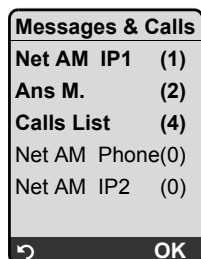

- ▶ Use  to select a list and press **OK**.

Calls list

Depending on the list type set, the Calls list contains

- ◆ Answered calls (identified by)
- ◆ Missed calls



The numbers of the last 30 calls are saved.

Multiple calls from the same number are stored once in the list of missed calls (the latest call). The number of calls from this number is shown in brackets after the entry.

Multiple calls from the same number are stored several times in the list of answered calls.

The list of missed calls contains unanswered calls and the calls recorded by the answering machine.

Please note

- ◆ Only calls to the receive numbers assigned to your handset are stored in the Calls list (→ [Page 168](#)).
If no receive numbers are assigned, all calls are stored in the Calls list for all handsets.
 - ◆ You can also call up the Calls list via the menu:  → 
 - ◆ Missed calls are not stored in the Calls list if they were taken on another phone registered with the same VoIP access data.
-

Setting the Calls list type

 →  → Base → Calls List Type

Missed Calls / All Calls

Select and press **OK** (= on).



Press and **hold** (idle status).

The Calls list entries are retained when you change the list type.

List entry in the Calls list

New messages appear at the top of the list.

Example of list entries:



- ◆ The list type in the header: **Missed Calls, All Calls**
- ◆ Status of entry
Bold: New entry

Using lists

- ◆ Number or name of the caller
The number is always saved in the list with the area code.
You can copy the caller's number to the directory, → [Page 74](#).
- ◆ Date and time of the call (if set, → [Page 16](#)).

Managing Calls list entries

Pressing the Display key **Delete** deletes the highlighted entry.

After pressing the Display key **Options** you can select other functions with :

Copy to directory

Copy a displayed number to the directory.

Information

If a URI was received and stored for a VoIP call, this is shown. The URI is dialed if you press the Talk key . The URI is not entered on the Last Number Redial list.

See also the following section "Display CNIP information".

Delete List

Delete complete list.

After exiting the calls list, all entries are set to "old" status and are no longer shown in bold.

Displaying CNIP information

If you have CNIP, you can display the name and town/city that is registered with your network provider for this number.

You have selected a list entry.

Options Open menu.

Information Select and press **OK**.

If the name and town/city are not shown, it means that the caller has not requested Caller ID or that Caller ID has been blocked.

Press **OK** to return to the list.

Selecting from the Calls list

 → **Calls List (2)**

 Select entry.

 Briefly press/press and hold the Talk key. The number is dialed using the selected connection type (→ [Page 45](#)).

Please note

Store your own area code on your phone (→ [Page 135](#), [Page 171](#)) so that the area code is automatically withheld during local calls on the fixed line network.

Answering Machine list

The Answering Machine list **Ans M.** is only displayed on handsets that have at least one receive number with the answering machine.

You can use the Answering Machine list to listen to messages on the base station's answering machine.

The first new message received is displayed at the start of the Answering Machine list. Playback starts when the list is opened.

New messages are placed after old messages when they have been played back.

All new messages are played back regardless of the associated receive number.

If the list does not contain any new messages, the old messages are played back.

List entry in the Answering Machine list



Example of list entries:

Message Playback	
Susi Sorglos	
15.01.09	12:20
Louise Miller	
14.01.09	11:15
Delete	Options

- ◆ Status of entry
Bold: New entry
- ◆ Number or name of the caller
You can copy the caller's number to the directory (→ [Page 74](#)).
- ◆ Date and time of the call (if set, → [Page 16](#)).

For further information on managing your messages from the Answering Machine list, → [Page 99](#).

Dialing numbers from the Answering Machine list

-  → Ans M. (2)
-  Select entry.
-  Briefly press/press and hold the Talk key. The number is dialed using the selected connection type (→ [Page 45](#)).

Using directories and Quick list

Using directories and Quick list

The options are:

- ◆ The handset's directory,
- ◆ The handset's Quick list

Handset directory/Quick list

You can store up to 250 entries on your handset's directory and Quick list (the total number of entries depends on the size of the individual entries).

You can set up individual directories and Quick lists for your handset. However, you can send the lists or individual entries to other handsets (→ [Page 73](#)).

Please note

For quick access to a number from the directory or Quick list (Quick dial), you can assign the number to a key (→ [Page 73](#)).

Local handset directory

In the local **directory** you can save

- ◆ Up to three numbers and associated first names and last names,
- ◆ VIP designation and VIP ringer (optional),
- ◆ E-mail address (optional),
- ◆ Caller ID images (optional)
- ◆ Anniversaries with reminder.

▶ With the handset in idle status, open the directory by pressing the  key.

Length of entries (directory)

3 numbers: each up to 32 digits

First name and last name: each up to 16 characters

E-mail address: maximum 60 characters

Please note

Some VoIP providers do not support local calls for calls to the fixed line network. In this case, always enter the fixed line number with the area code in your directory. Alternately, you can also use the Web configurator to define an area code, which is automatically prefixed to all numbers that are dialed via VoIP without an area code (→ [Page 171](#)).

Please note that (depending on the fixed line network provider), when local calls are made via the fixed line network the number cannot be dialed with an area code.

Quick list

In the **Quick list** you can save area codes of network providers ("call-by-call numbers") with which you can prefix the numbers when dialing via the fixed line network.

- ▶ Opening the Quick list in idle status with the  key.

Entry length

Number: maximum 32 digits
Name: maximum 16 characters

Storing a number in the directory

 → **New Entry**

- ▶ Change multiple line input:

First Name / Last Name:

Enter a name in at least one of the fields.

Phone / Phone (Office) / Phone (Mobile)

Enter a number in at least one of the fields.

E-mail

Enter e-mail address.

Annivers.

Select **On** or **Off**.

With the setting **On**:

Enter **Anniversary (Date)** and **Annivers. (Time)** (→ [Page 74](#)) and select reminder type: **Annivers. (Signal)**.

Caller Picture

Prerequisite: Caller ID (CID).

If required, select an image to be displayed when the caller calls.

The images are saved in the My Stuff section of the handset (→ [Page 130](#)).

Save

Press the Display key to save changes.

Please note

- ◆ For information on how to enter IP addresses, → [Page 47](#).
 - ◆ To dial a number using a certain line connection each time, you can add the relevant line suffix to the number in question (→ [Page 47](#)).
 - ◆ You can use the Web configurator to save the directory to a file on your PC, where it can be edited and then sent back to the handset (→ [Page 183](#)). Or you can transfer Outlook contacts from the PC to the handset's directory.
-

Using directories and Quick list

Saving a number in the Quick list

 → **New Entry**

▶ Change multiple line input:



Number:

Enter number.



Name:

Enter name.

Selecting a directory entry/Quick list entry

 /  Open the directory or Quick list.

You have the following options:

- ◆ Use  to scroll through the entries until the required name is selected.
- ◆ Enter the first character of the name (in the directory: first character of the last name or of the first name if **only** the first name has been entered), or scroll to the entry using .

Dialing using the directory/Quick list



 /  →  (Select entry; → [Page 72](#))

 Briefly press/press and hold Talk key. The number is dialed using the selected connection type (→ [Page 45](#)).

Please note

You can only dial IP addresses via VoIP.

Managing directory/Quick list entries

 /  →  (Select entry; → [Page 72](#))



Viewing entries

View Press the Display key. The entry is displayed.
Go back with **OK**.

Editing entries

View **Edit** Press the Display keys one after the other.
▶ Carry out changes and save.

Using other functions

 /  →  (Select entry; → [Page 72](#))

Options Open menu.

The following functions can be selected with :

Display Number

Edit or add to a saved number and then dial it (press Talk key .

Edit Entry

Edit selected entry.

Using directories and Quick list

Delete Entry

Delete selected entry.

VIP Entry(directory only)

Mark the directory entry as **VIP** (Very Important Person) and assign it a specific ringer. You can then identify VIP calls by the ringer.

Prerequisite: Caller ID (→ [Page 49](#)).

Copy Entry

Send a single entry to a handset (→ [Page 73](#)).

Delete List

Delete all entries in the directory or the Quick list.

Copy List

Send complete list to a handset (→ [Page 73](#)).

Available Memory

Display the number of free entries in the directory and the Quick list.

Using Quick dial keys

How to assign numbers to the digit keys on your handset, → [Page 124](#).

▶ Press and **hold** the required Quick dial key.

If there is a valid line suffix at the end of the number in the directory (e.g.: #1), the number is dialed via the line belonging to the suffix (→ [Page 155](#)).

If no suffix is entered, the number is dialed via the default connection. Exception: A dialing plan has been defined for the number (→ [Page 172](#)).

Transferring the directory/Quick list to another handset

Prerequisites:

- ◆ The sending and receiving handsets must both be registered to the same base station.
- ◆ The other handset can send and receive directory entries.

 /  →  (Select entry; → [Page 72](#)) → **Options** → Copy Entry / Copy List → to Internal

 Select the internal number of the receiving handset and press **OK**.

A successful transfer is confirmed by a message and by the confirmation tone on the receiving handset.

You can transfer several individual entries one after the other by responding **Yes** to the **Copy next entry?** prompt.

Using directories and Quick list

Please note

You can also send the complete **directory** via data transfer without opening the directory:

 →  → **Data Transfer** → **Directory**

- ◆ Entries with identical numbers are not overwritten on the receiving handset.
- ◆ The transfer is canceled if the phone rings or if the memory of the receiving handset is full.

Copying a displayed number to the directory

You can copy numbers that are displayed in a list, e.g. the Calls list or Last Number Redial list or during a call to the directory.

If you have CNIP, the first 16 characters of the transmitted name are copied to the **Last Name** line.

A number is displayed:

Options → **Copy to directory**

Or:

 Press Display key.

The directory is opened.

New Entry/ Directory entry

Select and press **OK**.

 /  / 

Select and press **OK**.

The number is copied to the corresponding number field (**Phone / Phone (Office) / Phone (Mobile)**).

- ▶ Complete the entry if necessary, → **Page 71**.

Message playback is interrupted while the number is being copied from the voicemail list.

Copying a number or e-mail address from the directory

There are many operating situations in which you can open the directory, e.g. to copy a number or e-mail address. Your handset need not be in idle status.

- ▶ Depending on the operating situation, open the directory with  or

.



 Select entry (→ **Page 72**).

Saving an anniversary in the directory

You can save an anniversary for every number in the directory and specify the time at which a reminder call is to be issued on that anniversary.

Using directories and Quick list

Anniversaries are automatically recorded in the calendar (→ [Page 110](#)).

 →  (Select entry; → [Page 72](#))

View **Edit**

Press the Display keys one after the other.



Skip to the line **Annivers...**



Select **On**.

Change multiple line input:

Anniversary (Date)

Enter day/month/year (8 digits).

Annivers. (Time)

Enter hour/minute for the reminder call (4 digits).

Annivers. (Signal)

Select type of reminder.



Save

Press the Display key to save the changes.

Please note

A time must be specified for reminder calls. If you select a visual signal, a time is not required and is automatically set to 00:00.

Deactivating an anniversary

 →  (Select entry; → [Page 72](#))

View **Edit**

Press the Display keys one after the other.



Skip to the line **Annivers..**



Select **Off**.

Save

Press the Display key.

Reminder call on an anniversary

A reminder call is signaled on the handset with the selected ringer.

You have the following options:

Off

Press the Display key to acknowledge and end the reminder call.

Viewing missed anniversaries

In idle status, you are reminded of an elapsed and unacknowledged anniversary by the **one-off** display of **Appoint.**

▶ View appointment:

Appoint.

Press the Display key.

You have the following options:

Delete

Delete reminder.

After deleting, press the Display key  or **Go Back**:

Back to idle status, **Appoint.** is no longer displayed.

You can still view missed anniversaries (→ [Page 111](#)).

Setting up Cost-effective calling

Setting up Cost-effective calling

Using the Internet (VoIP) is the preferred cost-effective way of making calls.

You can also use your phone's cost control function for calls to fixed line or cellular phone networks. Open accounts with various VoIP providers who offer favorable rates for calls to other networks. In the phone configuration, define the most cost-effective VoIP connection (account), e.g. for specific regional, national or cellular network prefixes, to be used when calls are made (**Dialling Plans** → **Page 172**). Or define the VoIP connection to be used when dialing the number (dialing with line suffix, → **Page 47**).

If you are using your fixed line network to make a call, choose a network provider that offers particularly favorable rates (call-by-call). You can manage call-by-call numbers in the Quick list.

Linking a call-by-call number to a number

You can prefix a network provider's number ("chaining") to numbers dialed via a fixed line network.



Open the Quick list.



Select entry (call-by-call number).



Press the Display key.

Display Number

Select and press **OK**.



Enter number or select a number from the directory (→ **Page 74**).

Press the Talk key (briefly/press and hold) so that the number is dialed via the fixed line network. Both numbers are dialed.

Please note

To enable the linked number to be dialed via the fixed line network, you can also append the line suffix #0 (for the fixed line network) to the numbers. Or you can define appropriate rules for call-by-call numbers (→ **Page 172**).

Displaying the call duration

The duration of each call appears in the display for calls made via a fixed line network and VoIP

- ◆ During the conversation,
- ◆ Until about three seconds after the call has ended if you do not replace the handset in the charging cradle.



Please note

The actual duration of the call can vary from that shown by a few seconds.

Managing E-mails

Your phone informs you when new e-mail messages for you have arrived in your incoming e-mail server. You can display the text (unstructured) contained in the e-mail messages on the handset.

You can set your phone to periodically connect to your incoming e-mail server and check whether you have new e-mail.

Any new messages that have been received are displayed on all Gigaset S67H handsets that have been registered: you will hear an advisory tone, the Message key  will flash and the  icon is displayed in the idle display.

Please note

The icon  is also displayed when there are new messenger messages.

If there are new e-mail messages, the list **E-mail:** is displayed after pressing the Message key .

You can use your phone to connect to the incoming e-mail server and display the sender, date and time of receipt, subject and message text for every e-mail message in the list of incoming mail (→ [Page 77](#)).

Prerequisites:

- ◆ You have set up an e-mail account with an ISP.
- ◆ The incoming e-mail server uses the POP3 protocol.
- ◆ You have saved the name of the incoming e-mail server and your personal access data (account name, password) in the phone (→ [Page 181](#)).

Opening the Incoming Mail list

 →  → E-mail

Or, if new e-mail messages exist (the Message key  flashes):

 → E-mail:

The phone sets up a connection to the incoming e-mail server. The list of e-mail messages stored there is displayed.

The sequence in which the e-mail messages are displayed is dependent on your POP3 server. Generally speaking, the new unread messages appear before old messages that have been read.

The following details are displayed for each e-mail: name or e-mail address of the sender (one line, abbreviated if necessary) and the date and time (date and time will only display correct values if the sender and recipient are located in the same time zone).

Managing E-mails

Typical display:

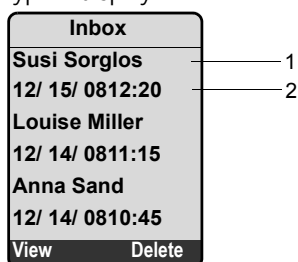

1 E-mail address or the name transmitted by the sender (abbreviated if necessary)

Bold: Message is new.

All e-mail messages that were not present in the incoming e-mail server when the Incoming Mail list was last opened are identified as "new". All other e-mails are not marked, regardless of whether or not they have been read.

2 Date and time of receipt of the e-mail message

If the Incoming Mail list on the incoming e-mail server is empty, then **No entries** is displayed.

Please note

Many e-mail providers operate standard spam protection measures. E-mail messages classified as spam are stored in a separate folder, and are therefore not displayed in the Incoming Mail list.

Some e-mail providers allow you to deactivate spam protection or show spam e-mails on the list of incoming mail.

Others may send a message to the inbox when a new spam e-mail is received. This is to inform you that a suspected spam e-mail has been received.

The date and sender of this mail are repeatedly updated, so that it is always displayed as a new message.

Messages when establishing a connection

The following problems may arise when connecting to the incoming e-mail server. The messages are displayed in the handset's display for a few seconds.

Server not accessible

It was not possible to set up a connection to the incoming e-mail server. The reasons for this may include:

- Wrong information on the name of the incoming e-mail server
(→ [Page 181](#))
- Temporary problems with the incoming e-mail server (not running or not connected to the Internet)
 - ▶ Check settings.
 - ▶ Try again later.

Currently not possible

The resources your phone requires to make the connection are busy, e.g.:

- Two VoIP connections have already been made.
 - ▶ Try again later.

Login failed

Error when logging into the incoming e-mail server. The reasons for this may include:

- Wrong information on the name of the incoming e-mail server, user name and/or password

▶ Check settings (→ [Page 181](#)).

Mailbox settings incomplete

Your information on the name of the incoming e-mail server, user name and/or password is incomplete.

▶ Check settings and complete if necessary (→ [Page 181](#)).

Reading e-mail messages

Prerequisite: You have opened the Incoming Mail list (→ [Page 77](#)).



Select an e-mail entry.

View

Press the Display key.

The subject and text of the e-mail message are displayed. Any attachments to the e-mail are not displayed.

Typical display:

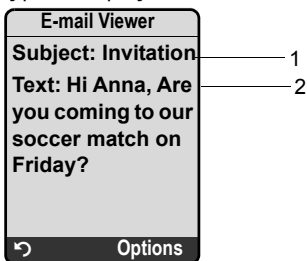

1 Subject of the e-mail message. A maximum of 120 characters are displayed.

2 Text of the e-mail message (abbreviated if necessary).

A maximum of the first 640 characters of the subject and message text are displayed in total (Subject + Text + "Subject:" + "Text:" = 640 characters).



Press the Display key to return to the Incoming Mail list.

Please note

- ◆ If the e-mail message contains more than just text, a brief message to this effect is displayed. The Subject of the message is then displayed.
- ◆ If the subject and/or message text are in HTML format, they may be displayed differently to how they appear on the PC e-mail client.

Managing E-mails

Viewing e-mail sender's address

Prerequisite: You have opened the e-mail message to read (→ [Page 79](#)).

Options Press the Display key.

From Select and press **OK**.

The sender's e-mail address is displayed in full (if necessary over several lines).

 Press the Display key to return to the Incoming Mail list.

Example:



Deleting e-mail messages

You have opened the Incoming Mail list (→ [Page 77](#)):

 Select an e-mail entry.

Delete Press the Display key.

Or:

You have opened the e-mail message to read (→ [Page 79](#)) or to display the email sender's address (→ [Page 80](#)):

Options Press the Display key.

Delete E-mail

Select and press **OK**.

The e-mail message is deleted on the incoming e-mail server.

Using the Instant Messenger (IM)

Your phone's messenger enables **instant messaging** (immediate message transfer, chatting). The phone supports the XMPP messenger (Jabber).

Instant messaging refers to communication between "friends" on the Internet. Subscribers exchange short messages, which are forwarded immediately. This results in a flowing "conversation" similar to chatting.

The prerequisite for this form of communication is that both subscribers have a connection to the **message server** of the same instant messaging provider. Therefore, both subscribers must be "**online**". The message server forwards the messages to the recipient.

The subscribers to instant messaging are called **buddies**.

Most message servers allow you to create **Buddy lists**. You can store the buddies you want to chat to in the Buddy list.

The message server informs you as soon as one of your buddies comes online or goes offline. **Offline** means that the buddy has disconnected from the message server.

In addition to this, each buddy can determine their own (communication) **status (state of presence, → Page 84)**, from which buddies can tell whether they are in the mood to chat or wish to remain undisturbed.

The Web configurator on your phone gives you the following options:

- ◆ Go **online** (→ [Page 82](#)).
- ◆ Display the list of your contacts (**buddies**) on the handset that you previously created on the PC. This will indicate for each buddy whether they are available (**online**) and ready to chat (**state of presence, → Page 84**).
- ◆ Exchange messages with your buddies. Your handset notifies you about new messages with a flashing Message key  and a beep.
- ◆ Call your buddies directly from your Buddy list (→ [Page 89](#)).

Prerequisites:

- ◆ You have registered with an instant messaging provider via the Web browser on your PC and (optionally) agreed a Web name (nickname).
- ◆ You have created a Buddy list via the messenger client on the PC.
- ◆ You have saved the message server address and your access data for the message server (user ID, password) in the phone using the Web configurator (→ [Page 179](#)). The phone needs the data to establish a connection with the message server.

Using the Instant Messenger (IM)

Please note

If your instant messaging provider doesn't support the phone's messenger client, you can open an account with an open Jabber server and use the Web configurator to enter its address in your phone. Many of these Jabber servers offer gateways to other message servers (e.g. AOL, ICQ, MSN, Yahoo!).

You can find a list of Jabber servers and an overview of the gateways to other message servers on the Internet at

<http://www.jabber.org>.

You can find information on setting up a Jabber account with connections from ICQ, MSN or Yahoo on the Internet, e.g. at:

<http://web.swissjabber.ch>

Establishing a connection, going online

When you go online, your Buddy list is displayed on the handset and you will receive messages from your buddies.

Only one of the handsets connected to the base station can connect to the message server. You can then only "chat" on this handset.

An external call will interrupt the chat, but you will still be online. You can continue your chat after you end or reject the call.

Prerequisite: You have saved the message server address and your access data for the message server (user ID and password) in the phone using the Web configurator (→ [Page 179](#)).

 →  → Messenger

Yes Press the Display key to confirm the prompt.

The phone attempts to establish a connection. You are informed about the status of the connection by messages on the display.

If the connection can be established, you are **Online**. The display will show the submenu for your messenger. You can open your Buddy list, send and receive messages and call your buddies.

The following is displayed when the handset is in idle status.

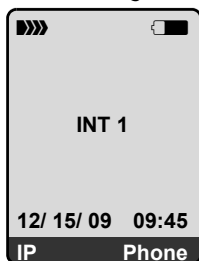

You remain online until you set your status to **Offline** (→ [Page 83](#)) or the connection to the message server is terminated (→ [Page 90](#)).

You also remain online if you press the End Call key .

Using the Instant Messenger (IM)

If the connection cannot be established, you will receive a message to that effect. Please try again later (→ [Page 90](#)).

Please note

You can also assign the messenger to one of the Display keys on your handset (→ [Page 124](#)). The connection is established when you press the Display key.

Lost connection

If your phone loses its connection to the message server, the Display key  will flash on the handset that had been connected to the messenger. In idle status it will display "**Messenger connection failed**". All messages that you had previously received, as well as any message you were currently writing, is saved.

Reconnecting:

 Press the Message key.

Yes Press the Display key to confirm the prompt.

The phone will attempt to reconnect. You are informed about the status of the connection by messages on the display.

If you reply to the request with **No** the phone will behave as during regular disconnection. All messenger messages are deleted. The phone is offline.

Changing/checking your personal status, going offline

You want to log off (go offline) or let your buddies know whether you wish to chat or would prefer to remain undisturbed.

You have the following options:

Offline

You log off from the message server. The message server informs the other buddies that you are no longer available.

The handset switches to idle status. You can neither send nor receive messages.

Online

(Setting after successful connection)

You are logged on to the message server and can send and receive messages.

Ready for chat

You are **Online** and can send and receive messages.

You invite your buddies to chat with you.

Away / Extended Away / Do not disturb

You are **Online** and can send and receive messages. You inform your buddies that you currently cannot/do not wish to chat, i.e. will not reply to their messages immediately.

Using the Instant Messenger (IM)

Invisible

You are **Online** and can send and receive messages.



However, the message server indicates to your buddies that you are **Offline**.

Please note

All status settings apart from **Offline** only inform other buddies about your communication status. Whether this information is passed on to your buddies depends on the provider.

Changing status

 →  → **Messenger** → **User Status** → **Change Status**

 Select status and press **OK** ( = on).

 Press **and hold** if necessary (idle status).

Disconnecting, going offline

▶ Select **Offline** status, and respond **Yes** to the security prompt.

The connection to the message server is terminated. The handset returns to idle status. New messenger messages are no longer sent to you. The Messenger's Message list is deleted. The Buddy list is no longer available.

Please note

Whether messages directed to you are deleted or stored in the message server depends on the provider. Stored messages are sent to you when you go online again.

Checking your status and user ID

 →  → **Messenger** → **User Status** → **Info**

If you are online, the following information may be displayed (depending on your provider):

- ◆ Your Web name (nickname, abbreviated if necessary)
- ◆ Your current status
- ◆ Your user ID (format: userid@provider-domain; abbreviated if necessary)

Opening the Buddy list

Prerequisite: You are **Online** and have already created a Buddy list (using the PC) on your provider's message server.

 →  → **Messenger** → **Buddies**

Only the first 20 (maximum) buddies on the Buddy list are read by the message server and displayed on the handset. The number depends on the available memory space.

The buddies that are displayed depend on which buddies were transferred from the message server first.

Please note

You can also receive and respond to messages from buddies who are not on the list displayed on the handset.

Example:

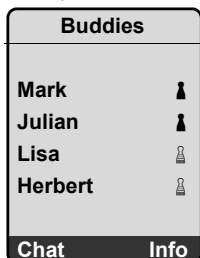

The Web names (nicknames) of your buddies are displayed on the list. If they do not have a Web name, the user ID is displayed.

If the name of a buddy is longer than one line, it is abbreviated. You can navigate the list with the Control key

The buddies appear on the list in the following order. Their status (→ [Page 83](#)) is identifiable by the color of the icon next to the buddies:

- 1** Buddies with **Online** status or **Ready for chat** in alphabetical order. The icon is **green**.
- 2** Buddies with **Away**, **Extended Away** or **Do not disturb** status in alphabetical order. The icon is **orange**.
- 3** Buddies with **Offline** or **Invisible** status in alphabetical order. The icon is **red**.

Please note

The Buddy list will remain open until you exit it (press and release or press and hold).

The handset will not automatically return to idle status.

Changes in the status of buddies

You have opened the Buddy list and one of the buddies changes their status. The following distinctions are made:

- ◆ A buddy changes to status **Online/ Ready for chat**:
You are informed via a message on the display. The Buddy list is updated.
- ◆ In the event of another status change, the Buddy list is updated. No message is displayed.

Please note

If the buddy changes to **Offline** status, your messages are no longer sent to them. Whether the message server stores the messages until the buddy is **Online** again or deletes them depends on the provider.

Using the Instant Messenger (IM)

Requesting information about buddies

You have opened the Buddy list (→ [Page 84](#)).

 Select buddy.

Info Press the Display key.

The display depends on the provider.

Example:

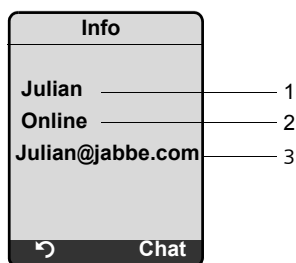

1 Web name (nickname, abbreviated if necessary)

2 Status

3 User ID (format: userid@provider-domain; abbreviated if necessary). (Resource names are not displayed)

Press  to return to your Buddy list. Press **Chat** to chat with the buddy.

Chatting to buddies

You want to chat to a buddy, i.e. send a message.

Prerequisite: You have opened the Buddy list (→ [Page 84](#)) and selected a buddy with .

- ▶ Press the Display key **Chat**. The text editor is opened.
- ▶ Write and send your message (→ [Page 88](#)).

The Buddy list is shown again.

Receiving messages

Prerequisite: You are online.

Newly arrived buddy or info messages (→ [Page 87](#)) are indicated by a flashing Message key  and a beep, even if you are in a messenger menu or text editor.

The messages are stored in the **Messenger: Message list**.

Please note

The **Messenger list** is only displayed if you are online.

Opening the Message list using the key

The Message key flashes.

- ▶ Press the Message key .

Using the Instant Messenger (IM)



- ▶ Select **Messenger: (2)** list if required and press **OK**. The number in brackets indicates the number of new messages.

Please note

If you are in the messenger menu or one of its submenus/text editors and you press the flashing Message key , this will open the **Messenger** list directly.

To open the Message list from the menu:

When the handset is in idle status:

 →  → **Messenger** → **Messages**
Select and press **OK**.

Message list

The messages on the list are sorted chronologically, with the oldest message at the head of the list.

Example of a list display:

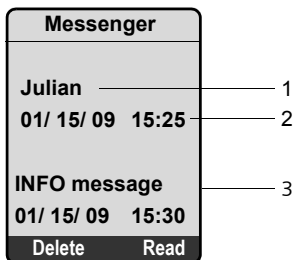

- 1 Sender's Web name/user ID
Bold: new/unread message
- 2 Date and time of message
- 3 Message from the message server (→ [Page 87](#))

If the memory is full and new messages arrive, the oldest message(s) are overwritten. If there are no old (read) messages, the oldest new (unread) messages are overwritten.

Message types

In instant messaging, a distinction is made between the following types of message:

- ◆ **Buddy messages** are the "instant messages" you receive from other buddies. You can answer the messages.
- ◆ **Info messages** are special information from the provider. They are forwarded to you, but you cannot reply to them.

Example: With some messaging providers you receive an info message when another subscriber tries to add you to their Buddy list. You are prompted to check the messages on the messenger client on your PC.

Via the messenger client on your PC, you can agree to the action or refuse permission. Without your agreement, the other subscriber cannot add you to their Buddy list.

Using the Instant Messenger (IM)

Reading messages

Prerequisite: You have opened the Message list and selected a message with .

- ▶ Press the Display key **Read**.

The message is opened for you to read.

You have the following options:

Delete Delete a message from the list. You will return to the Message list.

Or:

Answer (for buddy messages only)
Reply to message. The text editor is opened. You can write a reply (→ **"Writing and sending messages"** on **Page 88**).

Or:

 Back to the Message list.

Delete message

Prerequisite: You have opened the Message list and selected a message with .

- ▶ Press the Display key **Delete**.

Writing and sending messages

Prerequisite:

- ◆ You are reading a buddy's message and press the Display key **Answer** or
- ◆ You have pressed the Display key **Chat** in the Buddy list or the buddy profiles.

A text editor is opened.

- ▶ Use the handset keys to enter a message (maximum 612 characters).
- ▶  → **Send** Select and press **OK**.

The message is sent to the buddy.

Please note

- ◆ Entering text with and without predictive text is described from **Page 203**.
 - ◆ Predictive text is activated as a default setting. How to activate/deactivate predictive text, → **Page 204**.
-

If the message server is unable to send the message to the buddy, a message is displayed.

- ▶ Confirm the message by pressing **OK**.

The text editor will re-open with your message. You can then retry sending the message.

Interruption while writing

If you receive a call while you are writing a message or the connection to the message server is interrupted, the text editor is terminated. Your message is stored temporarily until ...

- ◆ ... You start up a chat with the same buddy (→ [Page 86](#)). The text editor is opened with the stored text. You can finish writing the message and send it.
- ◆ ... You wish to write a message to another buddy. The stored text is deleted. The text editor is empty.
- ◆ ... You go offline. The text is deleted.

Menu options for the text editor

Within the text editor  offers the following options:

Send

Send message to buddy.

Delete Text

Delete the whole text.

Predictive Text

Activate/deactivate predictive text, → [Page 203](#).

Select Language

For predictive text: select the language in which you wish to write the text and press **OK**.

Calling a buddy

You can call a buddy directly.

Prerequisite: The message server supports calls using vCard and your buddy's vCard contains a phone number.

Prerequisites:

- ◆ You have opened the Buddy list and selected a buddy
or
- ◆ You have opened the buddy's profile
or
- ◆ You have opened the **Messenger:** list and selected a buddy
or
- ◆ You are reading a message from a buddy

 /  Press and **release/hold** the talk or Speaker key.

The phone will try to establish a VoIP/fixed line connection.

The first number found on the vCard is dialed.

Ending a call

 Press the End Call key.

Using the Instant Messenger (IM)

Self-help with errors

While establishing a connection to the message server, during connection and when sending messages the following errors may occur.

Behavior when the connection is lost

If the connection to the message server is interrupted, an appropriate message is shown in the display. You are **Offline**.

If you are in a submenu of the messenger, the handset switches to the messenger menu.

- ▶ Try to re-establish the connection (→ [Page 82](#)).

Errors when sending

If it is not possible to send a message, a distinction is made between the following situations:

- ◆ The connection to the message server is interrupted:
 - A message is shown in the display to indicate that the connection to the message server has been interrupted.
 - The message is stored temporarily (→ [Page 89](#)).
 - ▶ Try to re-establish the connection (→ [Page 82](#)) and send the message again.
- ◆ The server is unable to send the message:
 - A message is shown in the display to indicate that the message could not be sent. If, for example, the buddy is not available, the message you have sent will also be displayed.
 - The message is stored temporarily (→ [Page 89](#)).
 - ▶ If necessary, check the buddy's user ID and send the message again later.

Info Center – with the handset always online

You can use your handset to retrieve online content from the Internet, i.e. request info services that are provided specially for the handset. The info services available are constantly updated. A preselection has already been made for your handset, but you can change these settings and add new services. Visit the Gigaset.net homepage www.gigaset.net on the Internet and compile your personal info services.

Customizing info services

- ▶ On the PC, open the **Settings** → **Services** page of the Web configurator.
- ▶ Click on the link gigaset.net/myaccount.

Or:

- ▶ Enter the following address in the address field of your PC's web browser: www.gigaset.net
- ▶ Enter your Gigaset.net user ID and password on the Gigaset.net page. You will find your user ID and password on the Web configurator page "**Settings** → **Services**", → **Page 181**).

In both cases a Web page is opened on which you can compile your info services.

Starting Info Center, selecting info services

 → Info Center

The menu of your Info Center, i.e. a list of available info services is displayed. You can navigate between the info services.

Example:

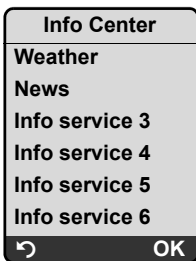

 Select info service and press **OK**.

To access certain info services (personalized services), you must register with a user name and password. In this case, enter your access data as described in the section "**Registering for personalized info services**" on **Page 92**.

Info Center – with the handset always online

Messages when loading requested information

The information is loaded from the Internet. Wait a few seconds until the information is displayed. The display shows **Please wait**.

If the information for an info service cannot be displayed, one of the following messages appears:

Requested page cannot be reached.

Possible causes of this are:

- ◆ Time limit exceeded (timeout) when loading the information, or
 - ◆ The Internet server for the info services cannot be accessed.
- ▶ Check your Internet connection and repeat the request at a later time.

Coding error on requested page.

The content of the requested info service is coded in a format which the handset cannot display.

Unable to show requested page.

General error when loading the info service.

Authorization failed.

Registration has failed. Possible causes of this are:

- ◆ You have not entered your registration data correctly.
 - ▶ Reselect the info service and repeat the registration process. Please remember that data is case sensitive.
- ◆ You are not entitled to access this info service.

Registering for personalized info services

If a special registration with user name and password is required to access an info service, the following is displayed after the service has been called up:

Username

Enter the user name supplied by the provider of the info service.

Password

Enter the password associated with this user name.

Save

Press the Display key to send the registration data.

If registration was successful, the requested info service is displayed.

Info Center – with the handset always online

If registration failed, a message to this effect appears on the display,

→ **Messages when loading requested information, Page 92.**

Please note



Please remember that registration data is case sensitive. To enter text

→ **Page 202.**

Operating the Info Center

Depending on the type of info service requested, you can carry out the following actions:

Scrolling within an info service

- ▶ You can use  to scroll downwards within an info service, and  to scroll up (back).

Skipping back to the previous page

- ▶ Press the left Display key .

Skipping back to the Info Center menu

- ▶ Briefly press the End Call key .



You want to go offline:

Press and **hold** the End Call key  to return the handset to idle status.

Selecting a hyperlink



Hyperlink to further information:

If the page contains a hyperlink to further information it is displayed using the  icon.



- ▶ You can use the Control key to select the hyperlink: navigate with  and/or  to the line containing the hyperlink. The hyperlink is then marked (highlighted against colored bars).
- ▶ Press the right Display key **Link** to open the associated page.

Hyperlink to a phone number:

If a hyperlink contains a phone number, you can copy the number to the local directory or call the number directly (Click-2-Call functionality).

- ▶ Select the hyperlink with  and/or  (navigate to the line containing the hyperlink).

You can identify a hyperlink of this type by the fact that **Call** is shown above the right Display key.

- ▶ Press   to copy the phone number to your handset's local directory (→ **Page 74**).

Or:

- ▶ Press **Call** to call the stored number.

Info Center – with the handset always online

If you press **Call**, then, depending on the provider:

- ◆ The number is either dialed immediately or
- ◆ It appears first in the display, in which case you must first confirm the number before it is dialed. Example:

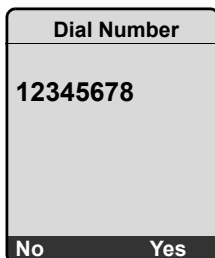

- ▶ If you press **Yes**, the number is dialed.

Or:

- ▶ If you press **No**, the page is redisplayed with the hyperlink. The number is **not** dialed.



Entering text

- ▶ Use  to mark the line containing the field into which you want to enter text. The cursor flashes in the text field.
- ▶ Enter the text using the keys on your handset.
- ▶ If necessary, navigate to other text fields to complete them or set an option (see below).
- ▶ Press the right Display key to complete the entry.

Making selections

- ▶ Use  to mark the line containing the field that you want to select.
- ▶ Press the left Display key to select the marked field.
- ▶ If necessary, navigate to other selection fields and make your selection as described above.
- ▶ Press the right Display key to complete the selection.

Setting options

- ▶ Use  to navigate to the line containing the option. The line is marked.
- ▶ Activate/deactivate the option using the Control key  or .
- ▶ If necessary, navigate to other options or text fields to set or complete them.
- ▶ Press the right Display key to complete the entry.

Displaying information from the Internet as a screensaver

You can configure your handset to display a customized information feed (e.g. weather reports, newsfeeds) in the device's idle display.

To do this, you must switch on the screensaver **Clock** on your handset (→ [Page 122](#)) and activate the display of info services via the Web configurator (→ [Page 182](#)).

Please note

For further information on selecting information, see [Page 181](#). The weather report is preset.

The text information appears on the display approx. 10 seconds after the handset returns to idle status.

Depending on the information feed selected, a Display key appears on the right of the screensaver (e.g. [More](#)),

- ▶ Press the right Display key to call up further information.
- ▶ Press and hold the End Call key  to return to idle status.

Operating the base station answering machine

Operating the base station answering machine

You can operate the answering machine that is integrated in the base station via the handset or via remote operation (other phone/cellular phone). You can record your own announcement message or advisory message via the handset.

Please note

Connections to the answering machine (internal and external) are not established using broadband.

Receive numbers

You can use your phone's Web configurator to set which of your phone numbers your answering machine is to accept as soon as it is switched on (→ [Page 170](#)). You can assign your phone any number of phone numbers as receive numbers (VoIP, fixed line network, Gigaset.net).

All calls accepted by the answering machine are stored in sequence in the answering machine independently of the receive number and displayed in the same Answering Machine list.

Any registered handset can access the Answering Machine list if it is assigned at least one receive number, by the answering machine, that is both a send and receive number (→ [Page 168](#)).

After a new phone number is configured (a new VoIP account), it is first assigned to the answering machine as a receive number.

Parallel calls

If a caller is connected to the answering machine and a second call for the answering machine comes in on a different line (fixed line network or VoIP), the second caller hears the ringing tone. The answering machine will answer the second call if:

- ◆ The connection with the first caller has ended and
- ◆ The set time period for the answering machine to answer a call (→ [Page 103](#)) has expired.

Announce only/answer and record mode

You can use the answering machine in two different modes.

- ◆ In **Ans. & Record** mode, the caller hears the announcement and can then leave a message.
- ◆ In **Announce Only** mode, the caller hears your announcement but cannot leave a message.

Using the handset

The handset loudspeaker activates **automatically** if you receive an audible prompt or message while operating. You can switch it off with the Speaker key .

Activating/deactivating the answering machine

 →  → Voice Mail → Local AM → Ans Machine (= on)

When the answering machine is activated, the remaining memory time is announced. If the time has not yet been set (→ [Page 16](#)), an appropriate announcement is made. The ∞ icon appears in the display.

The answering machine accepts calls for all the receive numbers assigned to it (→ [Page 170](#)).

In answer and record mode



If the memory is full the answering machine automatically switches to announce only mode.

- ▶ Delete old messages.

The answering machine reverts automatically to answer and record mode.

Selecting announcement mode

You can choose between **Ans. & Record** and **Announce Only**.

 →  → Voice Mail → Local AM → Announcements → Set Ans. Mode → Ans. & Record / Announce Only (= on)

 Press and **hold** (idle status).

The selected mode is saved even after the answering machine is deactivated.

The selection process is canceled if the message memory is already full when you change to **Ans. & Record** mode. You is requested to delete old messages.

The answering machine stays in **Announce Only** mode.

- ▶ Delete old messages.

Only after messages have been deleted can you switch the answering machine to answer and record mode.

Setting "Ans Mode Time" in "Ans. & Record" or "Announce Only" mode

You can use the **Ans Mode Time** setting to automatically switch the announcement mode for a specific period of time.

Example: **Ans. & Record** mode is set. If you activate **Ans Mode Time** and set the time period **From** 18.00, **Until** 08:00 the answering machine will switch to **Announce Only** mode every day at 18:00 (if it is switched on). It will switch back to **Ans. & Record** mode at 08:00 the next day.

 →  → Voice Mail → Local AM → Announcements → Set Ans. Mode → Ans Mode Time (= on)

- ▶ Change multiple line input:

From

Enter hours/minutes for the start of the period in 4-digit format.

Until

Enter hours/minutes for the end of the period in 4-digit format.

Operating the base station answering machine

Activation

Select **On** or **Off**.

- ▶ Save changes with **Save**.

If the messages memory is full and **Activation On** has been selected, saving is interrupted and you will receive an instruction to delete old messages.

- ▶ Delete old messages and repeat the setting.

As soon as you change the announcement mode (→ **Page 97**), the **Ans Mode Time** function is automatically deactivated. You may have to reactivate it if required.

If you do not enter a time for **From/Until**, **Ans Mode Time** will still be activated but the machine will not switch to announcement mode.

Recording a personal announcement/advisory message

Pre-recorded announcements are stored in your telephone for both announcement modes. The pre-recorded announcements are used if there is no personal announcement for the mode concerned.

 →  → **Voice Mail** → **Local AM** → **Announcements** → **Rec. Announcement / Record Ann Only**

OK Press the Display key to start the recording.

When the recording starts, the handset changes to speaker mode. You hear the ready tone (short tone).

- ▶ Now speak your announcement (at least 3 seconds).

Use  or  to cancel recording and **OK** to restart the recording process.

The recording is canceled if the answering machine memory is full.

- ▶ Delete old messages and repeat recording if required.

Stop recording:

End Press the Display key.

After recording, the announcement is played back for you to check.

You can re-record the announcement with **New**.

You can cancel playback by pressing  or .

Please note

- ◆ Recording ends automatically if the maximum recording time of 170 seconds is exceeded or there is a break in speech for more than 2 seconds.
 - ◆ If you cancel the recording, the previously recorded announcement is deleted. The pre-recorded announcement is used again.
 - ◆ The recording is canceled if the answering machine memory is full.
 - ▶ Delete old messages and repeat recording if required.
 - ◆ If an external call is received during a recording for one of the handset's receive numbers, the recording is interrupted and the call is signaled on the handset.
-

Operating the base station answering machine

Playing back announcements



 →  → Voice Mail → Local AM → Announcements → Play Announcement/
Play Ann Only

If you have not recorded a personal announcement, the relevant pre-recorded announcement is played.

Record a new announcement while playing back the announcement:

New Press the Display key. For further information, → [Page 98](#).

Deleting announcements/advisory messages

 →  → Voice Mail → Local AM → Announcements → Del. Announcement/
Del Ann Only

Yes Press the Display key to confirm the prompt.

 Press and **hold** (idle status).

Once you have deleted your announcement, the relevant pre-recorded announcement is used again. You cannot delete the pre-recorded announcements.

Playing back messages

New messages that have not yet been heard are indicated by the ∞ icon in the display and by the  key flashing on the handset.

You can start to play back the messages in two ways:

- ◆ Open the Answering Machine list with the Message key.
- ◆ If the answering machine is set for fast access (→ [Page 104](#)): press and **hold** key .

Please note

All messages are played back regardless of their receive number.

Listening to messages via the Answering Machine list

Prerequisite: At least one of your handset's send/receive numbers matches the receive number of a stored message.

The date and time of each message is logged in the Answering Machine list (provided it has been set, → [Page 16](#)) and displayed during the playback. If Caller ID is activated, the caller's number or name is displayed. If the caller's number is saved in the directory, their name is displayed.

 Press the Message key.

Ans M. Select and press **OK**.

An announcement informs you if there are new or old messages.

If there are new messages, playback begins with the first new message. If the message has been saved with the date and time, you will hear an appropriate announcement before playback begins. All messages are played back regardless of the receive number.

Operating the base station answering machine

After the last new message you will hear the end tone and an announcement about how much recording time remains.

You can listen to old messages if there are no more new messages. Begin or resume playback as described above.

Listening to messages via key



Prerequisites: The answering machine has been set to fast access (→ [Page 104](#)). At least one of your handset's send/receive numbers matches the receive number of a stored message (→ [Page 170](#)).



▶ Press and **hold** key .



The stored messages are now played back.

Pausing and controlling playback

During message playback:

 Pause playback. Press  again to resume.

 or  Skip to the previous message.

 or  Skip to the next message.

2 x  Skip to next-but-one message.

If playback is interrupted for over a minute, the answering machine returns to idle status.

Reading CNIP information of a message

▶ Please see [Page 68](#).

Marking a message as "new"

A previously played back "old" message is displayed as a "new" message again.

During message playback or pause:

 Press the Asterisk key.

Or:

Options Open menu.

Mark as New

Select and press **OK**.

Playback of the current message is canceled. Playback of next message starts, if applicable.

The  key on the handset flashes.

Copying the phone number of a message to the directory

See "[Copying a displayed number to the directory](#)", → [Page 74](#).

Operating the base station answering machine

Deleting messages

You can either delete all old messages together or individually.

Deleting all old messages

During playback or pause:

Options Press the Display key.

Del All Old Msgs

Select and press **OK**.

Yes Press the Display key to confirm the prompt.

All old messages are deleted regardless of the receive number.

Deleting individual old messages

During playback or pause:

Delete / **0**

Press the Display key or **0** key.

Please note

You can delete a new message as soon as playback has started.

Picking up a call from the answering machine

You can pick up a call while the answering machine is recording or is being operated via remote operation:

Accept

Press the Talk or Display key.

Recording stops and you can speak to the caller.

If 3 seconds of the call have already been recorded when you pick it up, the call is displayed as a new message. The **15** key on the handset flashes.

Forwarding an external call to the answering machine

You can forward an incoming external call to the answering machine.

Prerequisites: There is sufficient free memory space. One of your handset's send/receive numbers matches a receive number of the answering machine.

An external call is signaled on the handset:

00 Press the Display key.

The answering machine immediately starts in recording mode and records the call. The set time for the call acceptance (→ [Page 103](#)) is ignored.

The Display key **00** will not be displayed if the memory is full.

Activating/deactivating two-way record

You can record an **external** call with the answering machine.

Prerequisite: You are conducting an external call. At least one of the handset's send/receive numbers is assigned to the answering machine as a receive number (→ [Page 170](#)).

Operating the base station answering machine

- ▶ Inform the caller that the call is being recorded.

Options Press the Display key.

Two-way Record

Select and press **OK**.

Two-way record is indicated on the display by an advisory text and is added to the answering machine list as a new message.

End Press the Display key to stop two-way record.

The maximum recording time depends on the memory available on the answering machine. If the memory is full, you will hear an end tone and the recording is aborted. The conversation recorded up to the end tone is then assigned to the answering machine list as a new message.

Please note

You can activate two-way record for conference calls and call swap with two external callers when making calls via a fixed line network.

Activating/deactivating call screening

During recording of a message you can screen a call via the handset loudspeaker.

Prerequisite: The number called is assigned to the handset as a receive number (→ [Page 168](#)).

Permanently activating/deactivating call screening

 →  → Voice Mail → Local AM

Call Screening

Select and press **OK** ( = activated)

 Press and **hold** (idle status).

Deactivating call screening for the current recording

You can deactivate the **Call Screening** function for the current call during recording via the handset.

 **Briefly** press the End Call key.

Setting up the answering machine

The answering machine has already been preset at the factory. Make individual settings using the handset.

Operating the base station answering machine

Ring delay/cost saving function for remote operation



You can set when you want the answering machine to accept a call.

The options are: **No delay**, after **10 sec.**, **18 sec.** or **30 sec.** and the cost-saving setting **Auto**.

In **Auto** mode, the following applies for ring delay:

- ◆ If there are no new messages, the answering machine answers a call after **20 seconds**.
- ◆ If new messages are present, the answering machine accepts a call after **10 seconds**.

When operating remotely you can tell after approx. 15 seconds that there are no new messages (otherwise the answering machine would already have accepted your call). There is no call charges if you hang up now.

 →  → **Voice Mail** → **Local AM** → **Ring Delay**

Select  **No delay / 10 sec. / 18 sec. / 30 sec. / Auto**.

Save Press the Display key.

 Press and **hold** (idle status).

Setting the recording time

You can set the maximum recording time of a message. You can choose between: **30 sec**, **60 sec**, **120 sec** or **Maximum**.

 →  → **Voice Mail** → **Local AM** → **Message Length**

 Select the recording time.

Save Press the Display key.

Setting the recording quality

Set the quality you require for your recordings. The options are: **Long Play**, **High**, **Excellent**. If the quality is higher, the maximum recording time is reduced.

 →  → **Voice Mail** → **Local AM** → **Record Quality**

 Select the recording quality.

Save Press the Display key.

Please note

Your announcements are always recorded at the Excellent setting.

Changing the language for voice prompt and pre-recorded announcement

 **8 tuv** **5 jkl** **9 wxyz** **2 abc**

Enter digits and press

1 oo **OK** to set English.

2 abc **OK** to set French.

Operating the base station answering machine

Configuring the answering machine for fast access

You can assign the local answering machine or one of your network mailboxes to key  for fast access (→ [Page 107](#)). This setting is handset-specific.

Configuring the local answering machine for fast access

Prerequisite: At least one of your handset's send/receive numbers matches a receive number of the answering machine.

 →  → **Voice Mail** → **Set Key 1**

Local AM Select and press **OK**.

 Press and **hold** (idle status).

Listening to messages on the answering machine

Prerequisite: The answering machine is set for fast access on the handset.

 Press and **hold**.

The messages are now played back. Hands-free operation is activated. You will hear the answering machine announcement.

 If necessary, press the Speaker key to switch it off.

Operating remotely

You can check and activate your answering machine from any other telephone (hotel, pay phone, etc.).

Prerequisites:

- ◆ You have set a system PIN other than 0000 (→ [Page 132](#)).
- ◆ The phone you are using for remote operation has tone dialing (DTMF), i.e. you hear different tones when you press the keys. Alternately, you can use a code transmitter (available from your cellular phone retailer).



Please note

Remote operation via VoIP connections is possible as long as DTMF signals are transmitted (depending on the provider) as SIP info messages, audible signals in the voice channel (inband or audio) or as special RTP data packets (pursuant to RFC2833).

Calling the answering machine and playing back messages

Prerequisite: Your answering machine is activated.

 Dial your own number that is assigned to the answering machine as a receive number.

  When you hear your announcement, press  and enter the system PIN.

You are informed whether any new messages have been recorded. The messages are now played back. All messages are played back regardless of their receive number. After the new messages, the old messages are played back. Finally, the remaining memory time is specified.

Operating the base station answering machine

You can control message playback using the keypad.

Please note

The answering machine will terminate the connection under the following circumstances:

- ◆ An incorrect system PIN has been entered.
- ◆ There are no messages in the answering machine.
- ◆ After the remaining memory announcement

Operating the answering machine via the keypad

The following keys are used for operation:

- 1 Previous:
Go to the start of the current message. Press repeatedly to go to the previous messages.
- 2 Stop/resume:
Stop playback. Press again to resume.
If there is a pause lasting longer than one minute, the connection to the answering machine is terminated.
- 3 Next:
Skip to next message. Press several times to go to the following messages.
- * New:
Mark current message as "new". Start playback of the following message.
- 0 Delete:
Delete current message.

Canceling remote operation

- ▶ Press the End Call key or replace the receiver.

Activating the answering machine

- ▶ Phone home and allow the phone to ring for around a minute. Use a phone number that has been assigned to the answering machine as a receive number.

You will hear: "Please enter PIN".

 Enter system PIN.

Your answering machine is activated in the set mode (→ [Page 97](#)). It tells you how much memory time is left.

The messages are now played back.

The answering machine cannot be deactivated remotely.

Using the network mailbox

Using the network mailbox

Some fixed network providers and VoIP providers offer answering machines on the network – these are known as network mailboxes.

Each network mailbox accepts incoming calls made via the corresponding line (fixed line network or corresponding VoIP phone number). To record all calls, you should therefore set up network mailboxes for both the fixed line network and for each of your VoIP connections.

You need to have **requested** the network mailbox for your fixed line network connection from your fixed line network provider. You can store the phone number for the fixed line network mailbox in the base station.

You can activate/deactivate the network mailboxes for your VoIP connections using your handset or the Web configurator. To do this, you only need the network mailbox phone number.

Activating/deactivating the network mailbox, entering numbers

You can manage the network mailboxes on your handset that are assigned to a receive number on the handset.

 →  **Settings** → **Voice Mail** → **Network AM(s)**

The list of the connections (VoIP and fixed line network) assigned to the handset as receive numbers is displayed, **Net AM xxx** is displayed where xxx is replaced by the standard name in the connection (IP1 to IP6, Fixed Ln.).

 Select connection and press **OK**.

You have selected a VoIP connection:

► Change multiple line input:

Status

Select **On** to activate the network mailbox. Select **Off** to deactivate.

Call No.

The number that is currently stored for the network mailbox is displayed.

Enter or change the phone number for the network mailbox if necessary.

With some VoIP providers your network mailbox phone number is downloaded together with the general VoIP provider data (→ [Page 156](#)), saved to your base station and displayed under **Call No.**

Save Press the Display key.

You have selected the fixed line network connection:

Call No.

Enter or change the phone number for the network mailbox.

Save Press the Display key.

You cannot activate/deactivate the network mailbox for the fixed line network connection via the handset. For how to activate/deactivate the network mailbox for the fixed line network connection please refer to the fixed line network provider's information.

Please note

For information on how to activate and deactivate network mailboxes via the Web configurator and to change their assigned numbers, → [Page 174](#).



Configuring the (network) mailbox for fast access

You can use fast access to make direct calls to a network mailbox or the integrated answering machine on the base station.

Assigning key 1 of the handset, changing assignments

The setting for fast access is handset-specific. You can assign a different mailbox to key  on each registered handset.

No mailbox is preconfigured for fast access in the default settings.



 Fast access is not yet set on the handset: Press and hold key .

Or:

 →  **Settings** → **Voice Mail** → **Set Key 1**

The list of the connections (VoIP and fixed line network) assigned to the handset as receive numbers is displayed, **Net AM xxx** is displayed where xxx is replaced by the standard name in the connection (IP1 to IP6, Fixed Ln.).

For the integrated answering machine of the base station, the entry **Local AM** is offered in the list (→ [Page 104](#)).

 Select entry and press **OK** ( = on).

When selecting a network mailbox:

If a number is already saved to the base station for the network mailbox, fast access is activated.

 Press and **hold** (idle status).

If no number has been saved for the network mailbox, a message is displayed to this effect.

You are prompted to enter the number for the network mailbox.

 Jump to the **Call No.** line.

 Enter the number for the network mailbox.

Save Press the Display key.

 Press and **hold** (idle status).

Fast access is automatically activated.

Please note

You can only assign fast access to **one** answering machine.

However, you can also call the network mailbox assigned to a handset's receive numbers directly via the Message key (→ [Page 108](#)).

Using the network mailbox

Call the network mailbox

 Press and **hold**.

If you have set a network mailbox for fast access you are connected straight to this network mailbox.

 If necessary, press the Speaker key.

You will hear the network mailbox announcement.

If you have set the integrated answering machine on the base station for fast access, message playback begins (→ [Page 104](#)).

Listening to messages on the network mailbox

Under the Message key  you will find a list for each network mailbox that fulfills the following requirements:

- ◆ The corresponding connections are assigned to the handset as receive numbers.
- ◆ The network mailbox phone number is saved on the base station.

You can call and check the network mailbox directly from the list.

When you press the Message key , the following is displayed:

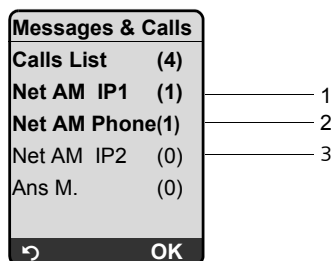

- 1 "Fixed Ln.", "IP1", etc. are the default names for the associated connections. The default names are always displayed regardless of which connection name you specified when configuring via the Web configurator.
- 2 If there are new messages in the network mailbox, the list entry is shown in bold. The number of new messages is shown in brackets following the list entry.
- 3 If there are no new messages, (0) is shown after the list entry for the network mailbox. The number of messages stored in the network mailbox is not displayed.

Displaying new messages in the handset's idle status

If a new message is present on one of the network mailboxes to which the handset is assigned via its receive number, or there is a new message on the integrated answering machine, the ∞ icon and the number of new messages are shown on the handset's idle display. The  Message key flashes.

Calling the network mailbox and checking messages

 Press the Message key.

Net AM Fixed Ln. / Net AM IP1 / ...

Select the network mailbox and press **OK**.

ECO DECT: Conserving energy

You are connected directly to the network mailbox and hear its announcement. Messages can generally be played back using your handset keypad (digit codes). Listen to the announcement.

Please note

- ◆ The network mailbox is automatically called via the corresponding connection. An area code predefined for your phone is **not** prefixed.
 - ◆ Network mailbox messages can generally be played back using your handset keypad (digit codes). You need to define how the digit codes for VoIP should be converted to DTMF signals and transmitted (→ [Page 175](#)).
- Ask your VoIP provider which type of DTMF transmission it supports.

ECO DECT: Conserving energy

The base station of your phone is an ECO DECT base station, this means that:

- ◆ The base station uses less power because it is equipped with a power-saving electrical adaptor.
- ◆ The reduction of the handset's transmission power is dependent on the handset's proximity to the base station.
- ◆ The base station can also be switched to **Eco Mode**. Eco mode reduces the transmission power and the power consumption of the base station further.

Eco Mode means:

80% reduction of the transmission power in standby mode and when making calls. **Eco Mode** is available when the handset(s) and the base station are close together, e.g. when the phone is being used in an office.

The setting can be made on the handset.

Activating/deactivating Eco Mode

 →  → Base → Add. Features

Eco Mode Select and press **OK** ( = on).

If eco mode is activated, the  icon is displayed at the top of the handset screen (header) in idle display.

The reception strength icon in the idle display header indicates whether the handset is connected to the base station:

- ▀▀▀ ▀▀▀ ▀▀▀ ▀▀▀ – reception poor to good
- D▀▀▀ (flashes) – no reception

Please note

- ◆ Activating **Eco Mode** reduces the base station's range.

Setting an appointment (calendar)

Setting an appointment (calendar)

You can use your handset to remind yourself of up to 30 appointments.

Anniversaries entered in the directory (→ [Page 74](#)) are automatically recorded in the calendar.

Saving an appointment

If you have already saved 30 appointments, you must first delete an existing appointment.

Prerequisite: The date and time have already been set (→ [Page 16](#)).



→ Open the graphical calendar.

Days on which appointments have already been saved are highlighted in black.



Select day and press **OK**.

If appointments have already been saved for the day, the list of appointments is displayed: select **<New Entry>** and press **OK**.

► Change multiple line input:

Appoint.

Select **On** or **Off**.

Date

Enter day/month/year (8 digits).

Time

Enter hours/minutes in 4-digit format.

Notes

Enter text (maximum of 16 characters). The text appears as the appointment name in the list and is displayed on the screen during the appointment reminder. If you do not enter any text, only the date and time of the appointment are displayed.



Press the Display key.

The list of appointments for the day selected is displayed. Activated appointments are marked in the appointments list with . The list of appointments is sorted by time.



Press and **hold** (idle status).

Managing appointments



Select the day in the graphical calendar and press **OK** or . Days on which appointments have already been saved are highlighted in black in the calendar.



Select appointment for the day.

Options

Open menu

Back with .

You have the following options:

View Entry

View selected appointment.

Options Open the menu for editing, deleting and activating/deactivating.

Edit Entry

Edit selected appointment.

Delete Entry

Delete selected appointment.

Activate / Deactivate

Activate/deactivate the selected appointment.

Delete List

Delete **all** appointments.

Deactivating or answering an appointment reminder

An appointment reminder is signaled with the selected ringer (→ [Page 127](#)). The appointment reminder sounds for 60 seconds. The entered text, date and time are displayed.

During a call, the appointment reminder is signaled by a short tone.

Prerequisite: An appointment reminder is sounding.

- ▶ Press the Display key **OFF** to switch off the appointment reminder.

Displaying missed appointments, anniversaries

Missed appointments/anniversaries (→ [Page 74](#)) are displayed in the **Missed Apts.** list if:

- ◆ You do not accept an appointment/anniversary.
- ◆ The appointment/anniversary was signaled during a phone call.
- ◆ The handset is deactivated at the time of the appointment/anniversary.
- ◆ Automatic redial was activated at the time of an appointment/anniversary (→ [Page 65](#)).

The most recent entry is at the head of the list.

If there is a new appointment/anniversary in the list, the display shows **Appoint.**. Pressing the Display key will also open the **Missed Apts.** list.

To open the list from the menu:

Setting the alarm clock

 →  → **Missed Appts.**

Select appointment/anniversary.
Information about the appointment/anniversary is displayed. A missed appointment is displayed with the appointment name and a missed anniversary is displayed with the last name and first name. The date and time will also be given.

Delete Delete appointment

 Press and **hold** (idle status).

If 10 entries are already stored in the list, the next appointment reminder will delete the oldest entry.

Setting the alarm clock

Prerequisite: The date and time have already been set (→ [Page 16](#)).

Activating/deactivating and setting the alarm clock

 → 

▶ Change multiple line input:

Activation

Select **On** or **Off**.

Time

Enter the wake-up time in 4-digit format.

Period:

Select **Daily** or **Monday-Friday**.

Volume:

Set the volume (1–6).

Melody:

Select melody.

▶ Press the Display key **Save** to save the changes.

You will see the  icon.

A wake-up call with the selected ringer is signaled on the handset. The wake-up call sounds for 60 seconds.  is shown in the display. If no key is pressed, the wake-up call is repeated twice at five-minute intervals and then turned off.

During a call, the wake-up call is only signaled by a short tone.

Deactivating the wake-up call/repeating after a pause (snooze mode)

Prerequisite: A wake-up call is sounding.

OFF Press the Display key. The wake-up call is deactivated.

or

Snooze Press the Display key or any key. The wake-up call is deactivated and then repeated after 5 minutes. After the second repetition the wake-up call is deactivated completely.

Using multiples handsets

Registering handsets

You can register up to six handsets to your base station.

You can register your Gigaset S67H handset on up to four base stations.

When you register a new Gigaset handset, the base station transfers the Gigaset.net entry for the Gigaset.net directory to its local directory to enable you to use the Gigaset.net directory on your new handset.

Prerequisite: The handset can send and receive directory entries. See the handset's user guide for further information.

Successful registration is acknowledged with the message **Data Transfer x entries received** for this reason.

Please note



- ◆ If a number of handsets are registered on your base station, you can simultaneously make two calls via the Internet and one via the fixed line network. Up to two additional internal connections are also possible.
 - ◆ Selecting the connection via the Talk key (→ [Page 45](#)) is not supported on GAP handsets. This means that if you enter a number without a line suffix and without defining a dialing plan for the phone number, it is dialed via **Default Line** (→ [Page 134](#)).
 - ◆ After registration, all the phone numbers for the phone are assigned to the handset as receive numbers. It will use the fixed line network number and the first VoIP number as send numbers. For information on how to change the assignments, → [Page 168](#).
-

Registering another Gigaset S67H handset on the Gigaset S675 IP

Before you can use your handset, you must register it to the base station.

You must initiate handset registration on the handset and on the base station.

If the handset has been registered successfully, the handset returns to idle status. The handset's internal number is shown in the display e.g. **Int 1**. If not, repeat the procedure. Registration can take up to one minute.

- ▶ Select  →  → **Handset** → **Register H/Set** on the handset.
- ▶ Enter the system PIN of the base station (the default is 0000) and press **OK**. The display shows e.g. **Base 1** and flashes.
- ▶ Within the next 60 seconds press and **hold** (for approx. 3 seconds) the **Registration/Paging** key (→ [Page 2](#)) **on the base station**.

The handset is assigned the lowest available internal number (1-6). If a number of handsets are registered on the base station, the internal number appears in the display after registration, e.g. **INT 2**. This means that the internal number 2 was assigned to the handset.

Using multiples handsets

Please note

If six handsets are already registered to the base station, there are two options:

- ◆ The handset with the internal number 6 is in idle status: the handset you wish to register is assigned the number 6. The handset that was previously number 6 is de-registered.
 - ◆ The handset with the internal number 6 is being used: the handset you wish to register cannot be registered.
-

Registering other handsets on the Gigaset S675 IP

You can register other Gigaset handsets and handsets for other devices with GAP functionality as follows.

- ▶ Start the registration procedure **on the handset** in accordance with the handset's operating instructions.
- ▶ Press and hold (for approx. 3 seconds) the Registration/Paging key (→ **Page 2**) **on the base station**.

Please note

You can also make changes on the base station with a Gigaset S45 or C47H handset.

De-registering handsets

You can de-register any registered handset from any registered Gigaset S67H handset.



Open list of internal participants.

The handset you are currently using is highlighted with <



Select the handset to be de-registered.

Options

Press the Display key.

De-reg. H/Set No.

Select and press **OK**.



Enter the base station system PIN (default setting: 0000).

Yes

Press the Display key to confirm the prompt.



Press and **hold** (idle status).

The handset is de-registered immediately, even if it is not in idle status.

Locating a handset ("paging")

You can locate your handset using the base station.



- ▶ **Briefly** press the Registration/Paging key on the base station (→ **Page 2**).
- ▶ All handsets will ring simultaneously ("paging"), even if ringers are switched off.

The current (local) IP address for the base station appears in the handset displays.

Ending paging

- ▶ Briefly press the Registration/Paging key on the base station (→ **Page 2**).

Or

- ▶ On a handset: press the Talk key  or End Call key  or Display key **Silence**.

Changing the base station

If your handset is registered to more than one base station, you can set it to a particular base station or to the base station that has the best reception (**Best Base**).

 →  → **Handset** → **Select Base**

 Select one of the registered base stations or **Best Base** and press **OK**.

Changing a handset's internal number

A handset is **automatically** assigned the lowest free number when it is registered. In the list of internal participants, the handsets are sorted according to their internal number.

You can change the internal number of all registered handsets (1–6). Numbers 1-6 can only be assigned once each.

 Open the list of handsets. Your own handset is indicated by <.

Options Press the Display key.

Edit H/Set No.

Select and press **OK**. The list of handsets and their internal numbers are displayed.

The internal number for the first handset flashes.

 Select handset.

 Enter the new internal number (1–6). The handset's old number is overwritten.

  If necessary, select further handsets and change numbers.

After all the changes are completed:

Save Press the Display key to save the input.

 Press and **hold** (idle status).





You will hear the error tone if an internal number has been assigned twice.

- ▶ Repeat the procedure with a free number.

Using multiples handsets

Changing the name of a handset

The names "INT 1", "INT 2", etc. are assigned automatically at registration. You can change these names. The changed name is displayed in every handset's list.

-  Open the list of handsets. Your own handset is indicated by <.
-  Select handset.
- Edit** Press the Display key.
-  Delete previous name if necessary.
-  Enter the new name (maximum 10 characters).
- Save** Press the Display key.
-  Press and **hold** (idle status).

Please note





If you delete the current handset name and then press **Save** without entering a new name, the handset will automatically be assigned the standard name "INT x" (x= internal number).

Making internal calls



Internal calls to other handsets registered on the same base station are free.

If both handsets are broadband-capable, internal calls will always be made via broadband.

Calling a specific handset

-  Initiate internal call.
-  Enter the number of the handset.
- Or:
-  Initiate internal call.
-  Select handset.
-  Press the Talk key.

Calling all handsets ("group call")

-  Initiate internal call.
-  Press the Asterisk key. All handsets are called.

Ending a call

-  Press the End Call key.

Please note

You can reject an internal call by pressing the End Call key . Other handsets will continue to signal an internal "group call".

Transferring a call to another handset

You can forward (connect) an external call, made via the fixed line network or VoIP, to another handset.

-  Open the list of handsets.
The external participant hears hold music if activated
(→ [Page 134](#)).

-  Select handset or **Call All** and press **OK**.

When the internal participant answers:

- ▶ If necessary announce the external call.

-  Press the End Call key.

The external call is transferred to the other handset.

If the internal participant does **not** answer or the line is busy, press the Display key **End** to return to the external call.

When transferring a call you can also press the End Call key  before the internal participant answers.

Then, if the internal participant does not answer or the line is busy, the call will automatically return to you (the display will show **Recall**).

Initiating internal consultation call, conference call

You are talking to an **external** participant (via fixed line network or VoIP) and can call an **internal** participant at the same time to hold a consultation call.

-  Open the list of handsets.
The external participant hears hold music if activated
(→ [Page 134](#)).

-  Select handset and press **OK**.

When an internal participant answers you can speak to them.

You have the following options:

Ending a consultation call



- End** Press the Display key.

You are reconnected with the external subscriber.

Initiating a conference call

- Conf.** Press the Display key.

You are in a three-way conference call with the external participant and the internal participant.

If the internal participant who has been called ends the call (press End Call key ) , you are connected with the external participant. If you press End Call key  , the external call is transferred to the internal subscriber.

Using a handset as a room monitor

Accepting/rejecting call waiting during an internal call

If you receive an **external** call during an **internal** call, you will hear the call waiting tone (short tone). With Caller ID, the caller's number or name will appear in the display.

Ending an internal call, accepting an external call

Accept Press the Display key.

The internal call is **ended**. You are connected to the external caller.

Rejecting the external call

Reject Press the Display key.

The call waiting tone is turned off. You remain connected with the internal participant. The ringer can still be heard on other registered handsets.

Using a handset as a room monitor

When the room monitor function is activated and the handset detects a specific noise level, the handset automatically calls a destination phone number. That phone number can be either another handset or an external number.

The room monitor call to an external number stops after around 90 seconds. The room monitor call to an internal number (handset) stops after approx. 3 minutes (depending on the base station). When the room monitor function is activated, all of the handset keys are deactivated except for the End Call key . The speaker of the handset is muted.

When the room monitor is activated, incoming calls to the handset are indicated **without a ringer** and are only shown on the screen. The display and keypad are not illuminated and advisory tones are also turned off.



If you accept an incoming call, the room monitor is suspended for the duration of the call, but the function **remains** activated.

If you deactivate then reactivate the handset, the room monitor remains activated.

Warning

- ◆ Always check the operation of the room monitor before use. For example, test its sensitivity. Check the connection if you are forwarding the room monitor to an outside number.
 - ◆ When the function is switched on, the handset's operating time is considerably reduced. If necessary, place the handset in the charging cradle. This ensures that the batteries do not run down.
 - ◆ Ideally the handset should be positioned 1 to 2 yards away from the baby. The microphone must be directed towards the baby.
 - ◆ The connection to which the room monitor is diverted must not be blocked by an activated answering machine.
-

Activating the room monitor and entering the destination number

 →  → Room Monitor

▶ Change multiple line input:

Room M.



Select On to activate.

Call to

External number:

▶ Select the number from the directory (press Display key ) or enter it directly. Only **the last 4 characters** are displayed.

Internal number:

▶ Press the Display key .
Select INT and press .

▶ Use  to select the handset or **Call All** (if all registered handsets are to be called) and press .

Level

Set noise level sensitivity (**Low** or **High**).

▶ Press the Display key  to save the changes.

The function is now activated.

You can use the  Display key to switch directly to the room monitor settings.

Please note

- ◆ If you do not specify a line suffix (→ [Page 47](#)) and you do not define any dialing plans for the number (→ [Page 172](#)), an external number is dialed via the set standard connection (VoIP or fixed line network).
 - ◆ The handset remains in room monitor mode even after deactivating and then reactivating.
-

Changing the set destination number

 →  → Room Monitor

 Skip to the line **Call to**.

 Delete existing number.

▶ Enter number as described in "[Activating the room monitor and entering the destination number](#)" (→ [Page 119](#)).

Using a handset as a room monitor

Deactivating the room monitor remotely

Prerequisites: The room monitor call is sent to an external destination number. The telephone called supports tone dialing.

- ▶ Accept a call at the handset acting as the room monitor and press keys **9** **#**.

Your base station sends a confirmation tone and ends the connection.

Please note

External deactivating via VoIP connections is possible as long as the DTMF signals are transmitted (depending on the provider) either as SIP info messages, audible signals in the voice channel (inband or audio) or as special RTP data packets (in compliance with RFC2833).

The room monitor function is deactivated on the handset. There will be no further room monitor calls. The other room monitor settings (e.g. no ringer) on the handset will remain activated until you press the Display key **OFF** on the handset.

To reactivate the room monitor with the same phone number:

- ▶ Turn on the activation again and save with **Save** (→ **Page 119**).

Handset settings

Your handset is preconfigured, but you can change the settings to suit your individual requirements.

Changing the display language

You can view the display texts in different languages.





 →  → **Handset** → **Language**

The current language is indicated by .

 Select a language and press **OK**.

 Press and **hold** (idle status).

If you accidentally choose a language you do not understand:

Press keys in sequence.

 Select the correct language and press **OK**.

— **Parts of the menu are not displayed in the language selected ...**

... and three or more handsets are registered on your base station. A language that is not one of the standard languages for the base station (= English (North America), Français (Amér. du Nord), Español) is set on at least three handsets.

Cause: Some display texts are only stored for the standard languages English, Français and Español on your base station. In addition, these display texts can be stored in the base station in two other languages or in another language for two different types of Gigaset handsets. When selecting the language on the handset, these texts are downloaded to the base station from the Internet. If another non-standard language is set on a third handset, then display texts appear in one of the standard languages on this handset.



Both non-standard languages, which are set with the lowest internal numbers, are stored on the base station.

If there is no further handset registered on the base station whose type and language setting correspond to an additionally loaded language, then the memory is freed up. If necessary, the language set for another registered handset is loaded onto the base station.

Handset settings

Setting the display

You have a choice of four color schemes and several different contrasts.

 →  → **Display**

Color Scheme

Select and press **OK**.



Select a color scheme and press **OK** ( = current color).



Press **briefly**.



Skip to the **Contrast** line.

Contrast

Select and press **OK**.



Select contrast.



Press the **Display** key.



Press and **hold** (idle status).

Setting the screensaver

You can select a picture from the Resource Dir. (→ [Page 130](#)) to be displayed as a screensaver in idle status. This will replace the idle status display. It may conceal the date, time and name.

The screensaver is not displayed in certain situations, e.g. during a call or if the handset is de-registered.

If a screensaver is activated, the **Screen Saver** menu option is marked with .



→  → **Display** → **Screen Saver**

The current setting is displayed.

▶ Change multiple line input:

Activation

Select **On** (screensaver is displayed) or **Off** (no screensaver).

Selection:

If required, change the screensaver (see below).

▶ Press the **Display** key  to save the changes.

If the screensaver conceals the display, **briefly** press  to show the idle display with time and date.

Changing the screensaver

 →  → Display → Screen Saver

 Skip to the **Selection** line.

View Press the Display key. The active screensaver is displayed.

 Select screensaver and press **Change**.

▶ Press the Display key **Save** to save the changes.

Please note

- ◆ If you have activated the **Clock** screensaver on your handset and activated the display of info services via the Web configurator (→ [Page 182](#)), the backlight on the handset in idle status is switched off (→ [Setting the display backlight](#), → [Page 123](#)):
If the backlight is off and you want to make a call or change settings on the handset, you must repeat the first key press (e.g. press the Control key  twice on the right to open the main menu). The first key press switches the backlight on and the info service text information is displayed.
 - ◆ The screensaver is not displayed in certain situations, e.g. during a call or if the handset is de-registered.
-

Setting the display backlight

Depending on whether or not the handset is in the charging cradle, you can activate or deactivate the display backlight in idle status.

Regardless of the setting that you have made, the display lights up with full intensity after you have pressed a key on the handset or when the handset signals a call, appointment or anniversary or carries out a wake-up call.

If you do not make any further entries or there is no signaling, the backlight is dimmed after approx. 15 seconds (including during a call). If the handset is in room monitor mode, the backlight switches off after 15 seconds.

- ◆ If you have switched the display backlight on, the display is permanently dimmed in idle status.
- ◆ If you have switched the display backlight off, the display remains dimmed for 45 seconds before switching off.

Activating/deactivating the display backlight in idle status

 →  → Display → Backlight

The current setting is displayed.

▶ Change multiple line input:

In Charger

Select **On** or **Off**.

without Charger

Select **On** or **Off**.

Save Press the Display key.

 Press and **hold** (idle status).

Handset settings

Please note

The handset's standby time can be significantly reduced if the display back-light (On) is activated.

Quickly accessing functions and numbers

You can assign the left Display key and each of the digit keys **0** (one) and **2** (abc) to **9** (xyz) a number or a function. The right Display key has a function pre-selected by default. You can change the assignment.

The number is then dialed or the function started by simply pressing a key.

Assigning a digit key/left Display key

Prerequisite: The digit key or the left Display key has not yet been assigned a number or a function.

▶ Press the Display key **?** or press and **hold** the digit key.

The list of possible key assignments is opened (see below).

▶ Select the function with the Control key **☑** and press **OK**. The handset returns to idle status.

The following features are available:

Quick Dial / Call-by-Call

Assign key to a number from the directory or Quick list.

The directory or Quick list is opened.

▶ Select an entry and press **OK**.

If you delete or edit an entry in the directory or Quick list, this has no effect on the assignment to the digit/Display key.

Please note

A number from the directory with a pound (#) at the end is dialed via the standard connection, otherwise it is always dialed via the non-standard connection (→ [Page 134](#)).

◆ INT (**INT**)

Opens the list of internal participants.

◆ Room Monitor (**Room M.**)

Assign menu for setting and activating the room monitor to a key (→ [Page 119](#)).

◆ Alarm Clock (**Alarm**)

Assign menu for setting and activating the alarm clock to a key (→ [Page 112](#)).

◆ Calendar (**Calendar**)

Opens the calendar to enter new or view saved appointments: **☑**

◆ Withhold No. (**Withhold**)

If you press the Display key **Withhold**, your phone number will not be transmitted for the next call and will therefore not appear in the recipient's display.

Handset settings

If you press the Display key **Withhold**, a number editor is opened.

Enter the phone number and press the Display key **Send**.

The number is always dialed via the fixed line network. This function does not support dialing with a line suffix.

◆ E-mail (EMail)

Opens the e-mail submenu for receiving and reading e-mail notifications (→ [Page 77](#)):

✉ → E-mail

◆ Messenger (Messgr.)

Opens the Messenger submenu for chatting with friends on the Internet (→ [Page 81](#)):

✉ → Messenger

◆ Phone Call (Phone)

Opens the predialing option for making a call via the fixed line network.

◆ IP Call (IP)

Opens the predialing option for making a call via VoIP.

If the Display keys have been assigned a shortcut, the selected function or name of the phone number in the directory or Quick list is displayed (abbreviated if necessary) in the bottom display line via the relevant Display key.

Starting the function, dialing the number

If the handset is in idle status, press and **hold** the digit key or press the Display key **briefly**.

Depending on the key assignment:

- ◆ Numbers are dialed directly.
- ◆ The function menu is opened.

Changing key assignments

Display key

- ▶ Press and **hold** the left or right Display key.

The list of possible key assignments is opened.

- ▶ Proceed as described when first assigning the key (→ [Page 124](#)).

Digit key

- ▶ Press the digit key **briefly**.



Change Press the Display key. The list of possible key assignments is displayed.

- ▶ Proceed as described when first assigning the key (→ [Page 124](#)).

Handset settings

Activating/deactivating auto answer

If you activate this function, when you receive a call you can simply lift the handset out of the charging cradle without having to press the Talk key .

 →  → Handset

Auto Answer

Select and press **OK** ( = on).



Press and **hold** (idle status).

Changing the speaker/earpiece volume

You can set the handset volume for speaker mode to five different levels and the earpiece volume to three different levels.

When the handset is in idle status:



Press the Control key at the top.

Handset Volume

Select and press **OK**.



Set the earpiece volume.



Skip to the **Spkrphone Volume** line.



Set the speaker volume.



Press the Display key if necessary to save the setting permanently.

Setting the volume during a call:



Press the Control key.



Select volume.



Press the Display key if necessary to save the setting permanently.

The setting is automatically saved after approx. 3 seconds.

If  is assigned with another function:



Open menu.

Volume Select and press **OK**.

Configure setting (see above).



Please note

You can also adjust the call volume via the menu



→  → **Audio Settings** → **Handset Volume**.

Changing ringers

- ◆ **Volume:**
You can choose between five volumes (1–5; e.g. volume 2 = ) and the "crescendo" ring (6; volume increases with each ring = ).
- ◆ **Ringers:**
You can select various ringers, melodies or any sound from My stuff (→ [Page 130](#)).

You can set different ringers for the following functions:

- ◆ **Ext. Calls:** for external calls
- ◆ **Internal Calls:** for internal calls
- ◆ **Appointments:** for set appointments (→ [Page 110](#))
- ◆ **All:** the same ringer for all functions

Settings for individual functions

Set the volume and melody depending on the type of signaling required.

When the handset is in idle status:

 Press the Control key at the top.

Ringer Settings

Select and press **OK**.

Ext. Calls / Internal Calls / Appointments

Select and press **OK**.

▶ Change multiple line input:

 Set volume (1–6).

 Skip to the next line.

 Select ringer.

Save Press the Display key to save the setting.

Same ringer for all functions

When the handset is in idle status:

 → **Ringer Settings** → **All**

▶ Set volume and ringer (see "[Settings for individual functions](#)").

Save Press the Display key to confirm the prompt.

 Press and **hold** (idle status).

Please note

You can also adjust the ringers via the menu

 →  → **Audio Settings** → **Ringer Settings**.

Handset settings

Activating/deactivating the ringer

You can deactivate the ringer on your handset before you answer a call or when the handset is in idle status; the ringer can be deactivated permanently or just for the current call. The ringer cannot be re-activated while an external call is in progress.

Deactivating the ringer permanently

 Press and **hold** the Asterisk key.

The  icon appears in the display.

Reactivating the ringer

 Press and **hold** the Asterisk key.



Deactivating the ringer for the current call

 Press the Display key.

Activating/deactivating the alert tone

In place of the ringer you can activate an alert tone. When you get a call, you will hear a **short tone** ("Beep") instead of the ringer.

 Press and **hold** the Asterisk key and **within 3 seconds**:

 Press the Display key. A call will now be signaled by **one** short alert tone.  appears in the display.

Activating/deactivating advisory tones

Your handset uses advisory tones to tell you about different activities and statuses. The following advisory tones can be activated/deactivated independently of each other:

- ◆ **Key tones:** every key press is confirmed.
- ◆ **Acknowledge tones:**
 - **Confirmation tone** (ascending tone sequence): at the end of an entry/setting and when a new entry arrives in the Calls list or Voicemail list.
 - **Error tone** (descending tone sequence): when you make an incorrect entry
 - **Menu end tone:** when scrolling to the end of a menu
- ◆ **Battery tone:** the batteries need to be charged.

When the handset is in idle status:



Press the Control key at the top.

Advisory Tones

Select and press **OK**.

- ▶ Change multiple line input:

Key Tones

Select **On** or **Off**.

Confirm.

Select **On** or **Off**.

Battery

Select **On**, **Off** or **In Call**. The battery warning tone is only activated/deactivated and only sounds during a call.

- ▶ Press the Display key **Save** to save the changes.

You cannot deactivate the confirmation tone for placing the handset in the charging cradle.

Please note

You can also adjust the ringers via the menu







→ **Audio Settings** → **Advisory Tones**.

Handset settings

Managing My stuff

My stuff on the handset manages sounds, which you can use as ringers, and pictures (CID pictures and screensavers), which you can use as caller pictures or as screensavers. **Prerequisite:** Caller ID (CID).

My stuff can manage the following media types:

Icon	Sound	Format
	Ringers	Standard
	Monophonic	Standard
	Polyphonic	.mid
	Picture: Caller ID picture or Screensaver	BMP 128 x 128 px or 128 x 66 px (px = pixels)

The icon is displayed in front of the name in My stuff. The handset arrives with various mono- and polyphonic sounds already installed.

You can listen to the available sounds and view the pictures.

The previously installed pictures are labeled with . You cannot rename or delete them.

Playing back sounds/viewing Caller ID pictures

 →  → Screensavers / Caller Pictures / Sounds (select entry)

Play / View

Press the Display key. Sounds are played back or pictures are displayed. Press the  key to switch between entries.

End /  Press the Display key. Playback of the sound or display of the picture ends.

While you are playing back sounds, you can also interrupt playback with the  key.

 Press and **hold** (idle status).

If you have saved a picture in an invalid data format, you will see an error message after selecting the entry. Cancel the operation with . Delete the picture with **Delete**.

Sounds: Setting the volume

During playback:

Volume Press the Display key.

 Set volume.

Save Press the Display key.

Renaming/deleting a picture

You have selected an entry.

Options Open menu.

If a picture cannot be deleted (🔒), these options are not available. Depending on the situation, you can select the following functions:

Delete Entry

The selected entry is deleted.

Delete List

All entries in the list that can be deleted are deleted.

Rename

Change the name (maximum 16 characters) and press **Save**. The entry is stored with the new name.

Setting your own area code

These numbers may already be preset.

 →  → **Handset** → **Area Codes**

Check that the (pre)set area code is correct.

▶ Change multiple line input:

 Select/change input field.

 Navigate in the input field.

 Delete number if necessary:
Press the Display key.

 Enter number.

Save Press the Display key.

Example:

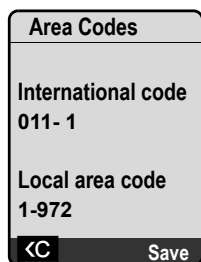

Area Codes

International code
011-1

Local area code
1-972

 **Save**

Please note

For further information about entering your own area code using the Web configurator, → [Page 171](#).

Setting the base station via the handset

Restoring the handset default settings

Each individual handset setting is reset – in particular the language, display, volume, ringers and alarm clock settings (→ [Page 121](#)). The Last Number Redial list is cleared.

Entries in the directory, the Quick list, the Calls list and the handset's registration to the base station as well as the content of My stuff are retained.

 →  → **Handset** → **Reset Handset**

Yes

Press the Display key.

You can cancel the factory reset by pressing  or the Display key **No**.



Press and **hold** (idle status).

Setting the base station via the handset

The base station settings are performed using a registered Gigaset S67H handset.

Protecting against unauthorized access

Protect the system settings of the base station with a PIN known only to yourself. You have to enter the system PIN if, among other things, you register and de-register a handset, change VoIP settings or reset the phone to factory settings.

Changing the system PIN

You have to enter the system pin when, for example, you register a handset with the base station, change VoIP settings or start the Web configurator.

You can change the 4-digit system PIN set on the base station (default setting: 0000) to a 4-digit system PIN known only by you.

 →  → **Base** → **System PIN**



Enter the current system PIN and press **OK**.



Enter new system PIN.



Skip to the line **Re-enter PIN**.



Now re-enter the new system PIN and press **OK**.

For security reasons, "****" is displayed instead of the system PIN.



Press and **hold** (idle status).

Resetting the system PIN

If you have forgotten your system PIN, you can reset the base station to the original PIN 0000. To do this, you must reset your base station using the key on the base station (→ [Resetting the base station using a key on the base station](#) on [Page 134](#)).

Please note that this will restore all other base station settings too (→ [Page 134](#)).

Restoring the base station to the factory settings

Resetting the base station via the menu

Each individual setting is reset, in particular:

- ◆ VoIP settings such as VoIP provider and account data and DTMF settings (→ [Page 137](#), [Page 154](#), [Page 175](#))
- ◆ Settings for the local network (→ [Page 139](#), [Page 151](#))
- ◆ Default connection (→ [Page 134](#))
- ◆ The names of the handsets (→ [Page 116](#))
- ◆ **Eco Mode** is deactivated (→ [Page 109](#)),
- ◆ Settings for the connection to the PABX (→ [Page 141](#))
- ◆ Answering machine settings (→ [Page 102](#)), and own announcements are deleted

The following lists are deleted:

- ◆ Calls list
- ◆ Answering machine lists

The following are **not** reset:

- ◆ Date and time
- ◆ System PIN

The handsets are still registered.



→ → **Base** → **Base Reset**



Enter the system PIN and press **OK**.



Press the Display key to confirm.

Setting the base station via the handset

Resetting the base station using a key on the base station



As with resetting the base station via the menu, all individual settings are reset. The **system PIN will also be reset to 0000** and **only the handsets registered to the base station at delivery are registered**.

Please note

For further information about reregistering the handsets after resetting, where applicable, → [Page 113](#).

- ▶ Remove the cable connections from the base station to the router (→ [Page 23](#)) and fixed line network (→ [Page 22](#)).
- ▶ Remove the base station power adapter from the socket (→ [Page 22](#)).
- ▶ **Press and hold** the Registration/Paging key (→ [Page 2](#)).
- ▶ Plug the power adapter back into the electrical socket.
- ▶ Continue to press and hold the registration/paging key (at least 2 seconds).
- ▶ Release the Registration/Paging key. The base station has now been reset.

Activating/deactivating music on hold

 →  → Base

Music on hold

Select and press **OK** to activate or deactivate music on hold (= on).

Setting default connection

You can make settings according to whether you want to make calls via VoIP or the fixed line network by default.

Please note

The standard connection is only relevant when dialing numbers that are not subject to dialing plans (→ [Page 172](#)) and are entered without a line suffix (→ [Page 47](#)).



 →  → Telephony → Default Line

VoIP / Fixed Line

Select and press **OK** (= on).

Setting the base station via the handset

When making calls:

- ▶ Press the Talk key  briefly to make the call via the default connection.
- ▶ Press and **hold** the Talk key  to make the call via the other connection type.

-  For information on how to make the setting on the Web configurator, → [Page 167](#).

Entering local and extra area codes

Use the following guidelines to make local calls (calls to the local fixed line network):

- ◆ Depending on the exchange, area codes are not dialed for local calls via your fixed line network. However, all calls are stored in the Calls list with access codes. To be able to call back a caller using the Calls list, you must store the local area code in the phone in whose area your phone is being used. If your phone is in a "multiple area code" area, you must also enter the other area codes that belong to this area as **extra codes**.
- ◆ With local calls via your VoIP connection the area code must also be dialed. If you have stored your area code in the phone and activated the **Predial area code for local calls through VoIP** option (→ [Page 171](#)), the area code entered is dialed automatically when dialing numbers without an area code (e.g. when dialing from the directory).

-  How to enter the area code with the Web configurator, → [Page 171](#).

Entering a local area code

 →  → **Telephony** → **Area Code**

 Enter the local area code.

 Press the Display key.

 Press and **hold** (idle status).

Entering extra codes

 →  → **Telephony** → **Extra Codes**

 Select an entry ("---" = blank entry) and press **Edit**.

 Enter the extra code.

 Press the Display key.

Repeat the above steps until all the extra codes have been entered for your area. A maximum of 5 extra codes can be stored.

 Press and **hold** (idle status).

Setting the base station via the handset

Updating the base station firmware

If necessary, you can update your base station firmware.

The firmware update is downloaded directly from the Internet by default. The relevant Web page is preconfigured in your phone.

Prerequisite:

The base station is in idle status, i.e.:

- ◆ No calls are being made via the fixed line network or VoIP.
- ◆ There is no internal connection between registered handsets or to GHC devices.
- ◆ No other handset has opened the base station menu.

Starting the firmware update manually

 →  → Base

Software Update

Select and press **OK**.



Enter the system PIN and press **OK**.

The base station establishes a connection to the Internet or to the local PC.

Yes

Press the Display key to start the firmware update.

Please note

- ◆ The firmware update can last up to 3 minutes.
 - ◆ When updating from the Internet, checks are made to ensure that no newer version of the firmware exists. If this is not the case, the operation is terminated and a message is issued to that effect.
-

Automatic firmware update

Your phone will check daily whether a more recent firmware version is available on the Gigaset configuration server on the Internet. If this is the case, the message **New firmware available** is displayed when the handset is in idle status and the Message key  flashes.



Press the Message key.

Yes

Press the Display key to confirm the prompt.

The firmware is loaded onto your phone.

If you respond to the prompt with **No**, the handset changes to idle status. Your phone will then remind you again about the firmware update at a later date (**New firmware available** is displayed again). However, you can also carry out a firmware update manually (→ [Page 136](#)).

Please note

If the telephone is not connected to the Internet at the time when the check for new firmware is to be carried out (e.g. because the router is deactivated), the check is carried out as soon as the phone is reconnected to the Internet.

-  You can deactivate the automatic version check via the Web configurator (→ [Page 187](#)).

Making VoIP settings

To use VoIP, you must set a few parameters for your phone.

You can make the following settings using your handset.

- ◆ Download the general access data for your VoIP provider from the Gigaset configuration server and store it on your phone.
- ◆ Enter your personal access data for your first VoIP account (first VoIP phone number). You can configure the access data for five further VoIP accounts via the phone's Web configurator.
- ◆ Set the phone's IP address in the LAN.

The connection assistant on your phone can help you make the settings.

-  You can set these and other parameters conveniently via the Web configurator on a PC connected to your local network (→ [Page 154](#)).

Using the connection assistant

The connection assistant starts automatically when you set the handset and base station up for the first time, or when you try to connect to the Internet before making the necessary settings.

You can also start the connection assistant via the menu:

 →  → **Telephony**

Connection Assist.

Select and press **OK**.



Enter the system PIN and press **OK**.

For how to enter VoIP settings using the connection assistant, → [Page 24](#).

Changing settings without the connection assistant

You can change your provider's VoIP settings and the VoIP user data via the menu without starting the connection assistant.

Downloading your VoIP provider's settings

The general settings for various VoIP providers are available to download on the Internet. The relevant Web page is preconfigured in your phone.

Prerequisite: Your phone is connected to the Internet.

 →  → **Telephony** → **VoIP**



Enter the system PIN and press **OK**.

Select Provider

Select and press **OK**.

The phone establishes a connection to the Internet.

Making VoIP settings

 Select country and press **OK**.

 Select your VoIP provider and press **OK**.

Your VoIP provider data is downloaded and saved in your phone.

If only one provider is available, the countries and providers lists are not displayed. Only the name of this provider will then appear in the display. To start the download, confirm with **OK**.

-  If your VoIP provider is not included in the list, you need to enter or adjust the general VoIP settings manually via your phone's Web configurator, → [Page 156](#).

Please note

If an error occurs during the download, an error message is displayed. You can find possible messages and measures in the table on [Page 190](#).

Automatic update for the VoIP provider settings

After the first download of the VoIP provider settings, your phone will check daily whether a newer version of the file for your VoIP provider is available via the Internet on the Gigaset configuration server. If this is the case, the message **New profile available** is displayed when the handset is in idle status, and the Message key  flashes.

 Press the Message key.

Yes Press the Display key to confirm the prompt.

 Enter the system PIN and press **OK**.

The new data for your VoIP provider is downloaded and saved on the phone.

If you respond to the prompt with **No**, the display will not be repeated. The message **New profile available** will only be shown again if a newer version of the VoIP settings than the one rejected is available.

Entering/changing VoIP user data

You must complete the VoIP settings with your personal data. You will receive all necessary data from your VoIP provider.

Please note

When making these entries, please remember the VoIP user data is case sensitive. To enter text → [Page 202](#).

 →  → **Telephony** → **VoIP** (Enter system PIN) → **Provider Registr.**

▶ Change multiple line input:

Username:

Enter the user name (caller ID) for your VoIP provider account. **Username** is often identical to your Internet telephone number (the first part of your SIP address, → [Page 158](#)).

User Name :/Authent. Password:

Enter the provider-dependent access data that has to be transferred by the phone to the SIP service at registration.

- ▶ Press **Save** to save the settings.

Please note

A previously set password is not displayed.

Setting the phone's IP address in LAN

The base station requires an IP address to be "recognized" by the LAN.

The IP address can be assigned to the base station automatically (by the router) or manually.

- ◆ If performed **dynamically**, the router's DHCP server automatically assigns the base station an IP address. The base station's IP address can be changed according to router settings.
- ◆ If performed manually/**statically**, you assign the base station a static IP address. This may be necessary depending on your network configuration.

-  For further information about making local network settings on the Web configurator, turn to **Page 151**.

Please note

To assign the IP address dynamically, the DHCP server on the router must be activated. Please also read the user guide for your router.

 →  → **Base** → **Local Network**

 Enter the system PIN and press **OK**.

- ▶ Change multiple line input:

IP Address Type:

Select **Static** or **Dynamic**.

If you select **Static**, you must manually define the IP address and the subnet mask for the base station in the next lines, as well as the standard gateway and DNS server.

IP Address:

For **IP Address Type = Dynamic**:

The IP address that is currently assigned to the base station is displayed. It cannot be changed.

For **IP Address Type = Static**:

Enter the IP address that is to be assigned to the base station (overwriting the current settings).

192.168.2.2 is the default.

For information on the IP address, please see **Page 151** and the glossary on **Page 230**.

Making VoIP settings

Subnet Mask:

For IP Address Type = Dynamic:

The subnet mask that is currently assigned to the base station is displayed. It cannot be amended.

For IP Address Type = Static:

Enter the subnet mask to be assigned to the base station (overwriting the current settings).

The default setting is 255.255.255.0

For information on the IP address, please see [Page 235](#) and the glossary on [Page 235](#).

DNS Server:

For IP Address Type = Static:

Enter the IP address for the preferred DNS server. The DNS server (Domain Name System) converts the symbolic name of a server (DNS name) to the public IP address for the server when the connection is made.

You can specify your router's IP address here. The router forwards phone address requests to its DNS server.

192.168.2.1 is the default.

Default Gateway:

For IP Address Type = Static:

Enter the IP address for the default gateway, by means of which the local network is connected to the Internet. This is generally the local (private) IP address for your router (e.g. 192.168.2.1). Your phone requires this information to be able to access the Internet.

192.168.2.1 is the default.

- ▶ Press **Save** to save the settings.

Activating/deactivating the display of VoIP status messages

If the function is activated, a VoIP status code for your service provider is displayed.

Activate the function if, for example, you have problems with VoIP connections. You will receive a provider-specific status code, which supports the service when the problem is analyzed. You will find a table with the possible status screens in the appendix (→ [Page 194](#)).

 →  → Telephony → VoIP

 Enter the system PIN and press **OK**.

Show Stat. on HS

Select and press **OK** (= on).

-  For information on how to make the setting on the Web configurator, → [Page 189](#).

Checking the base station MAC address

Depending on your network configuration, you may have to enter your base station MAC address, for example, into your router's access Control list. You can check your base station MAC address:



The base station MAC address is displayed.



Press and **hold** (idle status).

- For information on how to check your MAC address on the Web configurator, → [Page 189](#).

Operating the base station on the PABX

The following settings are only necessary when your PABX requires them; see the PABX user guide. The settings only concern fixed line network connections.

Changing the dialing mode

You can set the dialing mode.



Tone / Pulse

Select and press **OK** (= on).



Press and **hold** (idle status).

Please note

- ◆ Suffix dialing (to select the connection) is not possible in pulse dialing mode:
A pound "#" is displayed when dialing, but is ignored when pulse dialing.
 - ◆ Enter an asterisk "*" to switch temporarily to tone dialing. The asterisk is not displayed.
-

Setting Flash

You can set the Flash option.

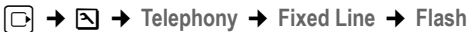

Select Flash and press **OK**.

The current setting is indicated by .



Press and **hold** (idle status).

Operating the base station on the PABX

Setting access codes (external line prefixes)

Depending on your PABX, you must dial an access code before making external calls to obtain an external line. You can store this access code in your phone. It is then added automatically to the numbers, e.g. when dialing using the Calls list.

 →  → Base → Add. Features

Access Code

Select and press **OK**.



Enter or edit the access code (maximum three characters) and press **OK**.



Press and **hold** (idle status).







If an access code is set, the following applies:

- ◆ The access code is added automatically when dialing from the Calls list/ Answering Machine list and when dialing emergency numbers.
- ◆ When dialing manually and dialing numbers from the directory, you must add the access code yourself.

Setting pauses

Changing pause after line activity

You can set the length of the pause inserted between pressing the Talk key  and sending the phone number.







     



Enter a number for the length of the pause (1 = 1 sec.; 2 = 3 sec.; 3 = 7 sec.) and press **OK**.

Changing the pause after the Flash key, access code

You can change the length of the pause if your PABX requires this (→ refer to the user guide for your PABX).



Enter a number for the length of the pause (1 = 800 ms; 2 = 1600 ms; 3 = 3200 ms) and press **OK**.

Switching temporarily to tone dialing (DTMF)

If your PABX still operates with dial pulsing (DP), but you need tone dialing for a connection (e.g. to listen to the network mailbox for your fixed line network connection), you must switch to tone dialing for the call.

Prerequisite: You are currently conducting an external call via the fixed line network or you have dialed an external fixed line network number or an external call is signaled.

Options Open menu.

Tone Dialing

Select and press **OK**.

Tone dialing is now activated **for this call only**.

Setting the phone with the PC

Setting the phone with the PC

The Web configurator is the Web interface for your phone. It allows you to select the settings for your phone's base station via your PC's Web browser.

The Web configurator on your phone provides you with the following options:

- ◆ Configure your phone access to the local network (IP address, gateway to the Internet).
- ◆ Configure your phone for VoIP. Assign up to six VoIP phone numbers to your telephone.
- ◆ Load new firmware onto the phone if necessary.
- ◆ Use Internet services: display text information on the handset (info services).
- ◆ Synchronize the telephone's date/time with a time server on the Internet.
- ◆ Copy contacts from the Outlook address book on your PC into the handset directories or back up your handsets' directories on your PC.
- ◆ Manage the names and internal numbers of registered handsets and your local directories
- ◆ Obtain information about your phone's status (firmware version, MAC address, etc.).

Prerequisites:

- ◆ A standard Web browser is installed on the PC, e.g. Internet Explorer version 6.0 or higher, or Firefox version 1.0.4 or higher.
- ◆ The phone and PC are connected with each other via a router.

Please note

- ◆ Depending on your VoIP provider, it is possible that you are unable to change individual settings in the Web configurator.
 - ◆ The phone is **not** blocked while you select your settings in the Web configurator. You can also use your phone to make calls or change base station or handset settings on your handset at the same time.
 - ◆ While you are connected to the Web configurator, it is blocked to other users. It cannot be accessed by more than one user at any time.
-

Connecting the PC with the telephone's Web configurator

Prerequisite: The settings of an available firewall installed on your PC allow the PC and phone to communicate with each other.

There are two ways of connecting your PC to the base station Web configurator:

- ◆ Via the (local) IP address of the base station
- ◆ Via Gigaset config

Setting the phone with the PC

Establishing a connection via the IP address:

- ▶ Establish the telephone's current IP address on the handset:
You can see the phone's current IP address in the handset display by **briefly** pressing the Registration/Paging key on the base station.
Your phone's IP address can change if you have activated dynamic IP address assignment (→ [Page 151](#)).

Warning

If one of the four parts of the IP address contains leading zeros (e.g. 002), these zeros must not be entered in the Web browser address field. Otherwise the Web browser will not be able to establish a connection to the Web configurator.

Example: The IP address 192.168.002.002 is displayed on the handset. Enter 192.168.2.2 in the address field.

- ▶ Launch the Web browser on your PC.
- ▶ Enter **http://** and the telephone's current IP address (for example: `http://192.168.2.2`) into the address field of the Web browser.
- ▶ Press the Return key.

A connection is established to the phone's Web configurator.

Establish a connection via Gigaset config:

Prerequisite: The router is connected to the Internet and your PC can access the Internet via the router.

- ▶ Launch the Web browser on your PC.
- ▶ Enter one of the following URLs into the Web browser's address field:
<http://www.gigaset-config.com>
<http://www.gigaset-device.com>
- ▶ Press the Return key.

You will receive a message stating that the connection will be forwarded to your base station.

If several Gigaset VoIP phones can be reached via your Internet connection, you are asked to which one of these phones you would like to be connected.

After successfully forwarding the connection, the **Login** Web page of the Web configurator is displayed in the Web browser.

Please note

The connection between the PC and the Web configurator is a local connection (LAN connection). The Internet is only accessed to establish the connection.

Setting the phone with the PC

Logging in, setting the Web configurator language

Once you have successfully established the connection, the **Login Web** page is displayed in the Web browser.

You can select the language you want the menus and Web configurator dialogs to be displayed in. The language that is currently selected is displayed in the top field of the Web page.

- ▶ If necessary, click  to open the list of available languages.
- ▶ Select the language.
- ▶ Enter your phone's system PIN (default setting: 0000) in the bottom field of the Web page, to access the Web configurator functions.
- ▶ Select **OK**.

Once you have successfully logged in, a **Home** screen opens with general information on the Web configurator.

If you enter an incorrect system PIN, a corresponding message is displayed. You are prompted to re-enter the PIN.

If you enter an incorrect system PIN a second time, the PIN field is blocked for a short time (grayed out). The duration of the block will double each time a PIN is subsequently entered incorrectly.

Please note

- ◆ If you have forgotten your system PIN, you must restore your device's factory settings. Please note that this will restore all other settings too (→ [Page 134](#)).
 - ◆ After approximately 10 minutes of inactivity, you are automatically logged off. The next time you try to make an entry or open a Web page, the **Login Web** page is displayed. Enter the system PIN again to log back in.
 - ◆ Any entries that you did not save on the phone before automatic log-off are lost.
-

Logging off

In the menu bar (→ [Page 147](#)) at the top right of every Web page in the Web configurator, you will see the **Log Off** command. Select **Log Off** to log off from the Web configurator.

Warning

Always use the **Log Off** command to end the connection to the Web configurator. If, for example, you close the Web browser without logging off beforehand, it is possible that access to the Web configurator is blocked for a few minutes.

Using the Web pages

The Web pages contain the UI elements displayed in Figure 1.

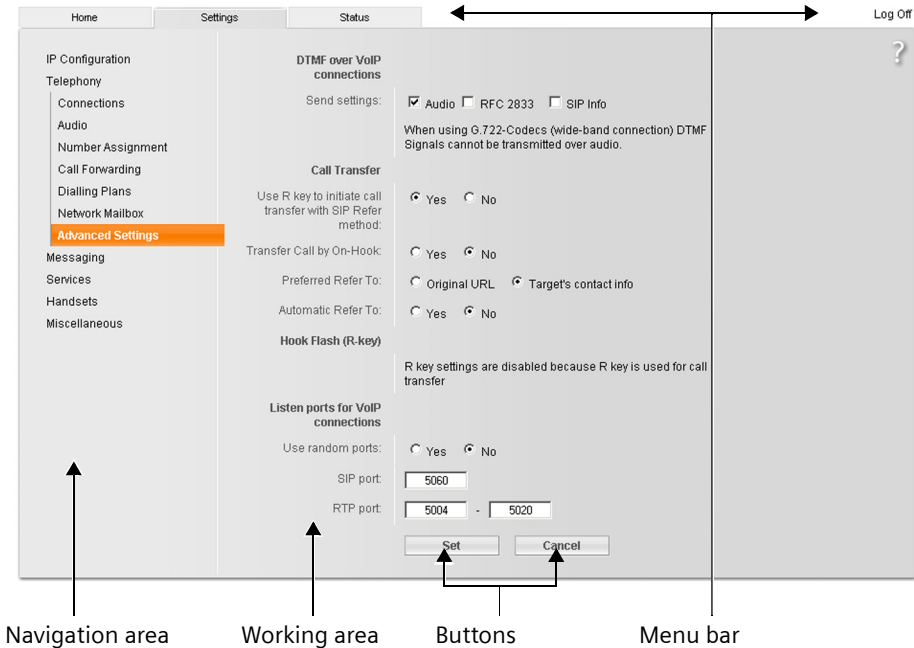

Figure 1 Example of the structure of a Web page

Menu bar

In the menu bar, the Web configurator menus are displayed in the form of tab pages.

The following menus are available:

- Home** The start screen is opened once you have registered with the Web configurator. It contains information on the Web configurator functions.
- Settings** This menu allows you to make settings on your phone (→ [Page 150](#)).
If you select the **Settings** menu, a list with this menu's functions is displayed in the navigation area (→ [Page 148](#)).
- Status** This menu provides you with information about your phone (→ [Page 189](#)).
- Log Off** You will find the **Log Off** function to the right of the menu bar on every Web page (→ [Page 146](#)).

Please note

For an overview of the Web configurator menus, → [Page 44](#).

Setting the phone with the PC

Navigation area

In the navigation area, the functions of the menu selected in the menu bar (→ [Page 147](#)) are listed.

If you select a function, the associated page opens in the working area with information and/or fields for your inputs.

If a function is assigned subfunctions, these are displayed with the function as soon as you select the function. The relevant page for the first subfunction is displayed in the working area.

Working area

Depending on the function selected, information or dialog boxes are displayed in the working area, which allow you to make or change your phone settings.

Making changes

Settings can be changed via input fields, lists or options.

- ◆ There may be restrictions regarding the possible values for a field, e.g. the maximum number of characters, entering special characters or certain value ranges.
- ◆ To open a list, select . You can select from preset values.
- ◆ There are two kinds of options:
 - Options in a list, from which you can activate one or several options. Active, i.e. selected options are highlighted with , non-active options with . You can activate an option by selecting . The status of the other options in the list does not change. You can deactivate an option by selecting .
 - Alternate options. The active option in the list is highlighted with , and the non-active with . You can activate an option by selecting . The previously activated option is deactivated. You can only deactivate an option by activating another option.

Entering Cyrillic and Arabic characters

In the following, the specified maximum number of characters permitted in a field refers to Latin characters and digits (1 character = 1 byte), i.e. 1 character means 1 byte.

Cyrillic and Arabic characters require 2 bytes each, i.e. with a field length of 16 characters, for example, you can enter a maximum of 8 Cyrillic or Arabic characters.

If you enter too many characters into a field, the entry is rejected (not saved on the base station). The "old" field content (e.g. the default settings) will remain in place and is displayed again when the web page is updated. No warning/confirmation is given.

Applying changes

As soon as you have made your change on a page, activate the new setting on the phone by selecting **Set**.

If your input in a field does not comply with the rules for this field, an appropriate error message is displayed. You can then repeat the input.

Warning

Changes that have not been saved on your phone are lost if you move to another Web page or if the Web configurator is logged off, e.g. due to exceeding the time limit (→ [Page 146](#)).

Buttons

Buttons are displayed in the bottom section of the working area.

Set Save entries on the phone.

Cancel Reject changes made on the Web page and reload the settings that are currently saved in your phone to the Web page.

Opening Web pages

A brief outline of the navigation to the individual Web configurator functions is given below.

Example

Setting DTMF signaling

Settings → **Telephony** → **Advanced Settings**

To open the Web page, carry out the following steps after registration:

- ▶ Select the **Settings** menu in the menu bar.
- ▶ Select the **Telephony** function in the navigation area.
The **Telephony** subfunctions are displayed in the navigation tree.
- ▶ Click the **Advanced Settings** subfunction.

The Web page from Figure 1 is shown in the Web browser.

Setting the phone with the PC

Setting the phone with the Web configurator

You can make the following settings using the Web configurator:

- ◆ Connect your phone to the local network (→ [Page 151](#))
- ◆ Configuration for telephony
 - Enter settings for the VoIP provider and configure or activate/deactivate VoIP accounts (→ [Page 156](#))
 - Specify the name of the fixed line network (→ [Page 162](#))
 - Activate/deactivate the Gigaset.net connection (→ [Page 163](#))
 - Activate/deactivate call forwarding for calls to your VoIP numbers or to your Gigaset.net number (→ [Page 170](#))
 - Configure settings to improve voice quality for the VoIP connections (→ [Page 163](#))
 - Define the default connection for your telephone (fixed line network or VoIP) (→ [Page 167](#))
 - Assign VoIP phone numbers to individual handsets as send/receive numbers (→ [Page 168](#))
 - Determine fixed line network and VoIP phone numbers for which the answering machine of the base station should record calls (→ [Page 170](#)).
 - Define user-specific dialing plans for emergency numbers and for cost control purposes (→ [Page 172](#))
 - Enter and activate/deactivate the network mailbox for each number assigned to the telephone (→ [Page 174](#))
 - Define the type of DTMF signaling (e.g. for remote operation of a VoIP network mailbox) and the Flash key function for VoIP (→ [Page 175](#)).
 - Enter settings for call forwarding via VoIP (call placing, i.e. connecting two external callers to each other, → [Page 176](#))
- ◆ Output of information from an IP info service on the handset (→ [Page 181](#))
- ◆ Synchronize date and time on the base station with a time server on the Internet (→ [Page 187](#))
- ◆ Start firmware updates (→ [Page 185](#))
- ◆ Manage registered handsets
 - Change names and internal numbers of the registered handsets (→ [Page 182](#))
 - Copy contacts from your PC's Outlook address book to the handset directories or save handset directories to your PC (→ [Page 183](#))
 - Activate/deactivate the display of VoIP status messages on your handset (→ [Page 185](#))

Configuring the IP

Assigning the IP address

Select the necessary settings for operating your phone in your local network and to connect it to the Internet. For more detailed explanations of the individual components/terms, see the glossary (→ [Page 224](#)).

- ▶ Open the following Web page: **Settings** → **IP Configuration**.
- ▶ In the **Address Assignment** area, select the **IP address type**.

Select **Obtained automatically** to use a dynamic IP address assigned by a DHCP server in your local network. No further settings are necessary for the local network.

Select **Static** to set up a static local IP address for your phone. A static IP address is, for example, useful if port forwarding or a DMZ is set up on the router for the phone.

The following fields are displayed when you select **IP address type = Static**:

IP address Enter an IP address for your phone. This IP address allows your phone to be reached by other subscribers in your local network (e.g. PC).

192.168.2.2 is the default.

Please note the following:

- ◆ The IP address must be from the address block for private use that is used in the router. This is generally in the range 192.168.0.1 – 192.168.255.254 with **Subnet mask** 255.255.255.0. The subnet mask determines that the first three parts of the IP address must be identical for all subscribers in your LAN.
- ◆ The static IP address must not belong to the address block (IP pool range) that is reserved for the DHCP server of the router. It must also not be used by another device on the router.

If necessary, check the settings on the router.

Subnet mask

Enter the subnet mask for your device's IP address. For addresses from the address block 192.168.0.1 – 192.168.255.254, the subnet mask 255.255.255.0 is generally used. This is preconfigured when the phone is supplied.

Default gateway

Enter the IP address for the default gateway uses to connect the local network to the Internet. This is generally the local (private) IP address for your router (e.g. 192.168.2.1). Your phone requires this information to be able to access the Internet.

192.168.2.1 is the default.

Setting the phone with the PC

Preferred DNS server

Enter the IP address for the preferred DNS server. DNS (Domain Name System) allows you to assign public IP addresses to symbolic names. The DNS server is required to convert the DNS name into the IP address when a connection is being established to a server.

You can specify your router's IP address here. The router forwards phone address requests to its DNS server.

192.168.2.1 is the default.

Alternate DNS server (optional)

Enter the IP address for the alternate DNS server that should be used in situations where the preferred DNS server cannot be reached.

▶ Select **Set** to save the changes.

Or

▶ Select **Cancel** to reject the changes.

After you have changed the IP configuration the base station is rebooted. You are logged off by the Web configurator. The **Login** Web page is displayed again after the reboot.

Allowing access from other networks

The default setting for your phone is set so that you can only access your phone's Web configurator via a PC that is in the same local network as your phone. The subnet mask of the PC must match that of the phone.

You can also allow access from PCs in other networks.

Warning

Expansion of access entitlement to other networks increases the risk of unauthorized access. It is therefore recommended that you deactivate remote access again if you no longer require it.

▶ Open the following Web page: **Settings** → **IP Configuration**.

Area: Remote Management

▶ Activate the **Yes** option to permit access from other networks.

To deactivate remote access, activate the **No** option. Access is then limited to PCs in your own local network.

Access to the Web configurator services from other networks is only possible if your router is set accordingly. The router must pass on the service requests from "outside" to Port 80 (default port) of the phone. Please also read the user guide for your router.

To establish a connection, the public IP address or the DNS name of the router and, where applicable, the port number on the router must be indicated in the Web browser of the remote PC.

Entering an HTTP proxy server (only when connected to an internal company network)

Direct connections between network participants and the Internet are often not permitted within internal company or organization networks (intranet). In such cases, all HTTP calls from the network are "transferred" by a proxy server. The proxy server is a computer or program within the network.

If your phone is connected to such a network, you must store the address of this HTTP proxy server on the phone and activate handling of HTTP calls via the HTTP proxy server.

Only then will you be able to access, for example, the Gigaset.net directory or obtain weather information, etc. in idle display (information services).

- ▶ Open the following Web page: **Settings** → **IP Configuration**.

Area: HTTP proxy

Enable proxy

Click the **Yes** option if your phone is to handle HTTP calls via your network's HTTP proxy server.

If you select **No**, the phone attempts to access the Internet directly.

Proxy server address

Enter the URL (→ [Page 236](#)) of the proxy server to which your phone is to send HTTP calls. The proxy server then creates the connection to the Internet.

Proxy server port

Specify the communication port used on the HTTP proxy server (number between 0 and 55000). Port 80 is usually assigned.

- ▶ Now select **Set** to save your settings.

Setting the phone with the PC

Configuring telephone connections

You can configure up to eight numbers on your phone: your fixed line network number, your Gigaset.net number and six VoIP numbers.

You need to set up a VoIP account with a VoIP provider for each VoIP phone number. You must save the access data for each account and for the relevant VoIP provider in the phone. You can assign a name to each connection (VoIP and fixed line network).

To configure the connections:

► Open the following Web page: **Settings** → **Telephony** → **Connections**.

A list (→ **Figure 2**) is shown containing all the possible connections that you can configure, or have already configured, on your phone.

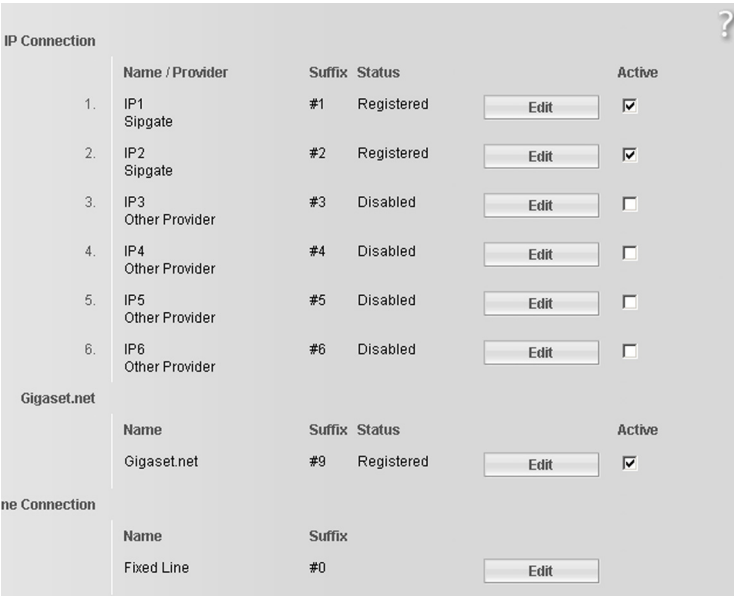

IP Connection					
	Name / Provider	Suffix	Status	Edit	Active
1.	IP1 Sipgate	#1	Registered	Edit	<input checked="" type="checkbox"/>
2.	IP2 Sipgate	#2	Registered	Edit	<input checked="" type="checkbox"/>
3.	IP3 Other Provider	#3	Disabled	Edit	<input type="checkbox"/>
4.	IP4 Other Provider	#4	Disabled	Edit	<input type="checkbox"/>
5.	IP5 Other Provider	#5	Disabled	Edit	<input type="checkbox"/>
6.	IP6 Other Provider	#6	Disabled	Edit	<input type="checkbox"/>
Gigaset.net					
	Name	Suffix	Status	Edit	Active
	Gigaset.net	#9	Registered	Edit	<input checked="" type="checkbox"/>
Fixed Line Connection					
	Name	Suffix		Edit	
	Fixed Line	#0		Edit	

Figure 2 List of possible connections

The list will show the following:

Name / Provider

Name of the connection. This will show the name that you have defined for the connection (→ **Page 156**, **Page 162**) or the default name (IP1 to IP6 for VoIP connections, **Fixed Line** for the fixed line network connection and **Gigaset.net**).

VoIP connections also display the name of the VoIP provider with which you have opened the account. If the name is unknown the display will show **Other Provider**.

Setting the phone with the PC

Suffix	<p>Line suffix that you have to add to the phone number of an outgoing call to allow the account assigned to the suffix to be used as the sending account.</p> <hr/> <p>Example</p> <p>If you dial 123456765#1, the connection is made and billed through the first VoIP account, regardless of the VoIP number you have assigned to your handset as the send number and whether you briefly press/press and hold the Talk key.</p> <p>If you dial 123456765#0, the connection is made via the fixed line network.</p> <hr/>
Status	<p>The status of the connection is shown for VoIP connections:</p> <p>Registered The connection is activated. The phone has been successfully registered. You can use the connection to make calls.</p> <p>Disabled The connection is deactivated. The phone is not registering with the corresponding account with the VoIP service. You cannot use the connection to make or receive calls.</p> <p>Registration failed / Server not accessible Your phone was unable to register with the VoIP service, e.g. because the VoIP access data is incorrect or incomplete or the phone is not connected to the Internet. You can find further information in the section "Questions and answers", → Page 190.</p>
Active	<p>You can use the option in the Active column to activate (<input checked="" type="checkbox"/>) and deactivate (<input type="checkbox"/>) VoIP connections. If a connection is deactivated, the phone will not register for this connection. The connection can be activated/deactivated by clicking directly on the option. The change does not need to be saved.</p> <p>To configure a connection or to change the configuration of a connection:</p> <ul style="list-style-type: none"> ▶ Select Edit button next to the connection. <p>This will open a Web page where you can make the settings needed. More information is available</p> <ul style="list-style-type: none"> ◆ In the section "Configuring the VoIP connection", → Page 156 or ◆ In the section "Configuring the fixed line connection", → Page 162 or ◆ In the section "Configuring the Gigaset.net connection", → Page 163.

Setting the phone with the PC

Configuring the VoIP connection

- ▶ Open the following Web page: **Settings** → **Telephony** → **Connections**.
- ▶ Select the **Edit** button next to the VoIP connection that you want to configure or the configuration you wish to change.

This will open a Web page where you can make the settings that your phone needs to access your provider's VoIP server.

The Web page always displays the following areas:

- ◆ **IP Connection** (→ **Page 156**),
- ◆ **Auto Configuration** (→ **Page 156**)
- ◆ **Personal Provider Data** (→ **Page 158**).

The areas

- ◆ **General Provider Data** (→ **Page 159**) and
- ◆ **Network** (→ **Page 160**)

can be shown and hidden by selecting the **Show Advanced Settings** and **Hide Advanced Settings** buttons.

You must enter the VoIP provider's general access data in these areas. You can download this data for many VoIP providers from the Internet (→ "**Area: Auto Configuration**", **Page 156**).

- ▶ Make the settings on the Web page.
- ▶ Save them in the phone → **Page 162**.
- ▶ Activate the connection if necessary → **Page 162**.

Area: IP Connection

Connection Name or Number

Enter a name for the VoIP connection or the VoIP phone number (maximum 16 characters). This name is used to display the connection on the handset and the Web configurator interface, e.g. during allocation of send and receive numbers (→ **Page 168**), for the call display (→ **Page 50**).

Area: Auto Configuration

The entire configuration process or a large part of the configuration for a VoIP connection is automated for many VoIP providers. You can download the necessary VoIP access data to your phone from the Internet.

You have the following options:

- ◆ Fully automated configuration

Prerequisites:

- You have received an **auto configuration code** from your VoIP provider.
- The general access data for your VoIP provider is available for downloading.

You can download all the data required for VoIP access from the Internet:

- ▶ Enter the auto configuration code you received from your VoIP provider in the **Auto Configuration** area in the **Auto Configuration Code** field (maximum 32 characters).

Setting the phone with the PC

- ▶ Select the **Start Auto Configuration** button.

The telephone establishes a connection to the Internet and downloads all data required for the VoIP connection, i.e. the general provider information and your personal provider data (account data) are saved to your base station.

If you have already entered details on the Web page, this is deleted as soon as **Start Auto Configuration** is selected. The fields in the **Personal Provider Data** and **General Provider Data** areas and the server addresses in the **Network** area are overwritten by the downloaded data.

Generally, you should not have to enter any additional data on this Web page.

Please note

If the message **Download of settings not possible! File is corrupt!** appears, no data is loaded onto the phone. Possible causes of this are:

- ◆ The incorrect code has been entered (e.g. upper/lower case rules have not been followed). If necessary, enter the code again.
 - ◆ The file that has been downloaded is invalid. Please consult your VoIP provider.
-

When the download is complete, the **Connections** list is displayed.

- ▶ Activate the connection as described on **Page 162**.

You can then be reached on the corresponding VoIP phone number.

- ◆ Automatic configuration of general VoIP provider data

Prerequisite: You have received your account details from your VoIP provider (e.g. **Authentication Name**, **Authentication password**).

Profile files for the most important VoIP providers are available to download from the Internet via the Gigaset configuration server. The address for the server is stored in your phone (→ **Page 185**).

To load the data onto your telephone, proceed as follows:

- ▶ Select **Select VoIP Provider** in the **Auto Configuration** area. This will display information on the download procedure.

Please note

If you select the **Select VoIP Provider** button, any changes that have been made to the Web page are saved and checked. Values may need to be corrected before the **Select VoIP Provider** operation is started.

The download procedure consists of several steps:

- ▶ Select the **Next** button.
- ▶ From the list, select the country for which the list of VoIP providers is to be loaded.
- ▶ Select the **Next** button.
- ▶ Select your VoIP provider from the list.

If your provider is not included in the list, select **Other Provider**. In this case you will have to enter the general provider data by hand (see "**Area: General Provider Data**" and "**Area: Network**" below).

Setting the phone with the PC

- ▶ Select the **Finish** button.

— Please note

If only one provider is available, the countries and providers lists are not displayed. The name of the provider is then displayed directly.

The details of the selected provider are loaded to your phone and saved under **General Provider Data** (→ [Page 159](#)) and **Network** (→ [Page 160](#)). You cannot make any further entries in these areas.

The **Provider** field shows the name of the selected provider or **Other Provider**. A link to the provider's homepage is displayed where available.

To complete configuration of your VoIP connection, enter your account data in the **Personal Provider Data** area.

— Please note

After the first download of the VoIP provider settings, your phone will check daily whether a newer version of the file for your VoIP provider is available via the Internet on the Gigaset configuration server (→ [Page 138](#)).

Area: Personal Provider Data

Enter the configuration data that is necessary for accessing your VoIP provider's SIP service. This data can be obtained from your VoIP provider.

The field names in this area (**Authentication Name**, etc.) listed in the following are standard names and may change. If you have already downloaded the provider's general details ("**Select VoIP Provider**" button, see above), field entries are replaced by provider-specific names to facilitate orientation (e.g. SIP-ID instead of **Authentication Name**).

Authentication Name

Specify the registration or authentication ID agreed with your VoIP provider (maximum 32 digits). The registration ID serves as the access ID that your phone must specify when registering with the SIP proxy/registrar server. The **Authentication Name** is usually identical to the **Username**, i.e. to your Internet phone number.

Authentication password

Enter the password that you have agreed with your VoIP provider in the **Authentication password** field (maximum 32 characters). The phone needs the password when registering with the SIP proxy/registrar server.

Username Enter the caller ID for your VoIP provider account (maximum 32 characters). This ID is usually identical to the first part of your SIP address (URI, your Internet phone number).

— Example

Example: If your SIP address is "987654321@provider.com", enter "987654321" as the **Username**.

Setting the phone with the PC

Display name (optional)

Enter any name that should be shown in the other caller's display when you call them via the Internet (example: Anna Sand). All characters in the UTF8 character set (Unicode) are permitted. The name must not exceed 32 characters.

If you do not enter a name, your **Username** or your VoIP phone number is displayed.

Ask your VoIP provider if this feature is supported.

Area: General Provider Data

If you have downloaded the general settings for the VoIP provider from the Gigaset configuration server (→ [Page 156](#)), then the fields in this area are pre-set with the data from the download. Generally, you do not need to configure any settings in this area.

Domain Specify the last part of your SIP address (URI) here (maximum 74 characters).

Example

For the SIP address "987654321@provider.com", enter "provider.com" in **Domain**.

Proxy server address

The SIP proxy is your VoIP provider's gateway server. Enter the IP address or the (fully-qualified) DNS name of your SIP proxy server (maximum 74 characters).

Example: myprovider.com.

Proxy server port

Enter the number of the communication port that the SIP proxy uses to send and receive signaling data (SIP port).

Port 5060 is used by most VoIP providers.

Registrar server

Enter the (fully-qualified) DNS name or the IP address of the registrar server (maximum 74 characters).

The registrar is needed when the phone is registered. It assigns the public IP address/port number to your SIP address (**Username@Domain**) used by the phone to log in. With most VoIP providers, the registrar server is identical to the SIP server. **Example:** reg.myprovider.com.

Registrar server port

Enter the communication port used in the registrar. Usually, port 5060 is used.

Registration refresh time

Enter the time intervals (in seconds) at which the phone should repeat the registration with the VoIP server (SIP proxy) (a request is sent to establish a session). The repeat is required so that the entry of the phone in the tables of the SIP proxy is retained and the phone can therefore be reached. The repeat is carried out for all activated VoIP phone numbers.

The default is 180 seconds.

If you enter 0 seconds, the registration will not be repeated periodically.

Setting the phone with the PC

Area: Network

Please note

If you have downloaded the general settings for your VoIP provider from the Gigaset configuration server (→ [Page 157](#)), then some fields in this area are preset with the data from the download (e.g. the settings for the STUN server and outbound proxy).

If your phone is connected to a router with NAT (Network Address Translation) and/or a firewall, you must select some settings in this area so that your phone can be reached from the Internet (i.e. can be addressed).

Through NAT, the IP addresses of subscribers in the LAN are concealed behind the public IP address of the router.

For incoming calls

If port forwarding is activated or a DMZ is set up for the phone on the router, no special settings are required for incoming calls.

If this is not the case, an entry in the NAT routing table (in the router) is necessary in order for the phone to be reached. This entry is created when the phone is registered with the SIP service. In the interest of security, this entry is automatically deleted at certain intervals (session timeout). The phone must therefore confirm its registration at certain intervals (→ [NAT refresh time on Page 161](#)) so that the entry stays in the routing table.

For outgoing calls

The phone needs its public address to receive caller voice data.

There are two possibilities:

- ◆ The phone requests the public address from a STUN server on the Internet (Simple Transversal of UDP over NAT). STUN can only be used with asymmetric NATs and non-blocking firewalls.
- ◆ The phone does not direct the connection request to the SIP proxy but to an outbound proxy on the Internet that supplies the data packets along with the public address.

The STUN server and outbound proxy are used alternately to work around the NAT/firewall in the router.

STUN enabled

Select **Yes** if you want your phone to use STUN as soon as it is used on a router with asymmetric NAT.

STUN server

Enter the (fully-qualified) DNS name or the IP address of the STUN server on the Internet (maximum 74 characters).

If you selected **Yes** in the **STUN enabled** field, you must enter a **STUN server** here.

STUN port Enter the number of the communication port on the STUN server. The default port is 3478.

Setting the phone with the PC

STUN refresh time

Enter the time intervals at which the phone should repeat the registration with the STUN server. The repeat is required so that the entry of the phone in the tables of the STUN server is retained. The repeat is carried out for all activated VoIP phone numbers.

Ask your VoIP provider for the **STUN refresh time**.

The default is 240 seconds.

If you enter 0 seconds, the registration will not be repeated periodically.

NAT refresh time

Specify the intervals at which you want the phone to update its entry in the NAT routing table. Specify an interval in seconds that is a little shorter than the NAT session timeout.

You should not need to change the preconfigured value for the **NAT refresh time**.

Outbound proxy mode

Specify when the outbound proxy should be used.

Always

All signaling and voice data sent by the phone is sent to the outbound proxy.

Auto

Data sent by the phone is only sent to the outbound proxy when the phone is connected to a router with symmetric NAT or blocking firewall. If the phone is behind an asymmetric NAT, the STUN server is used.

If you have set **STUN enabled** = **No** or have not entered a STUN server, the outbound proxy is always used.

Never

The outbound proxy is not used.

If you do not make an entry in the **Outbound proxy** field, the phone behaves independently of the selected mode, as with **Never**.

Outbound proxy

Enter the (fully qualified) DNS name or the IP address of your provider's outbound proxy (maximum 74 characters).

Please note

With many providers, the outbound proxy is identical to the SIP proxy.

Outbound proxy port

Enter the number of the communication port used by the outbound proxy.

The default port is 5060.

Setting the phone with the PC

Saving settings on the phone

- ▶ Select **Set** to save the changes.
The **Connections** list is shown after saving (→ [Figure 2](#) on [Page 154](#)).

To discard the changes:

- ▶ Select the **Cancel** button.

If all fields are to be reset to the default settings:

- ▶ Select the **Delete** button.

Fields without default settings are empty.

Please note

If you do not make any entries for a longer period, the connection to the Web configurator is automatically terminated. Unsaved entries are lost. If necessary, save intermittently. You can subsequently continue the entry and make changes if necessary.

Activating a new connection

If you have configured a new VoIP connection, you must also activate it.

In the Connections list:

- ▶ Activate the relevant option in the **Active** column (= activated).

Your phone will register itself with the VoIP provider using the relevant access data. Refresh the Web page (e.g. by pressing F5).

The **Status Registered** column will appear if registration was successful. You can now be reached on this VoIP phone number.

Please note

Once the new entry has been made, the VoIP phone number is assigned to each handset and the integrated answering machine as a receive number. For how to adjust the assignment, → [Page 168](#).

Configuring the fixed line connection

You can assign a name to your fixed line connection. This name is used to display the connection on the handset and the Web configurator interface, e.g. during allocation of send and receive numbers (→ [Page 168](#)), for the call display (→ [Page 50](#)).

- ▶ Open the following Web page: **Settings** → **Telephony** → **Connections**.
- ▶ Select the **Edit** button in the **Fixed Line Connection** area.
- ▶ Enter your fixed line network number or the name of your choice (maximum 16 characters) for your fixed line connection in the **Connection Name or Number** field. The default is "Fixed Line".

Configuring the Gigaset.net connection

Your phone is assigned a Gigaset.net phone number by default. As soon as you have connected your phone to the Internet, you can make calls using the Gigaset.net and receive calls from other Gigaset.net subscribers, provided that your Gigaset.net connection has been activated. You can deactivate the Gigaset.net connection.

Activating/deactivating the Gigaset.net connection

- ▶ Open the following Web page: **Settings** → **Telephony** → **Connections**. The list of connections is displayed (→ **Figure 2** on **Page 154**).
- ▶ In the **Gigaset.net** area: use the option in the **Active** column to activate () or deactivate () the Gigaset.net connection.

Please note

If you do not use your Gigaset.net connection for six weeks, it is automatically deactivated. You cannot be reached for calls from Gigaset.net.

The connection is reactivated:

- ◆ As soon as you start a search in the Gigaset.net directory (→ **Page 56**) or
 - ◆ Make a call via Gigaset.net, i.e. dial a number ending in #9 (two attempts may be necessary) or
 - ◆ Activate the connection via the Web configurator as described above.
-

Activating/deactivating the STUN server of the Gigaset.net connection

The Gigaset.net connection is preconfigured in your phone. The Gigaset.net uses a STUN server as standard. In the sent data packets, Gigaset.net replaces the private IP address of your phone with its public IP address.

If you operate your phone behind a router with symmetrical NAT, STUN cannot be used. Otherwise, when making Gigaset.net calls you will not be able to hear the caller.

In this case, deactivate STUN for the Gigaset.net connection.

- ▶ Open the following Web page: **Settings** → **Telephony** → **Connections**.
- ▶ Select **Edit** in the **Gigaset.net** area.

STUN enabled

Click **No** to deactivate STUN.

Select **Yes** if you want your phone to use STUN.

- ▶ Select **Set** to save the changes.

Optimizing voice quality for VoIP connections

You can make general and connection-specific settings to improve the voice quality for VoIP telephony.

- ▶ Open the following Web page: **Settings** → **Telephony** → **Audio**.

The voice quality for VoIP connections is mainly determined by the **voice codec** used for transferring the data and the available **bandwidth** of your DSL connection.

Setting the phone with the PC

In the case of the voice codec, the voice data is digitalized (coded/decoded) and compressed. A "better" codec (better voice quality) means more data needs to be transferred, i.e. perfect voice data transfer requires a DSL connection with a larger bandwidth.

The following voice codecs are supported by your phone:

G.722 Excellent voice quality. The **broadband** speech codec **G.722** works at the same bit rate as G.711 (64 kbit/s per speech connection) but with a higher sampling rate. This allows higher frequencies to be played back. The speech tone is therefore clearer and better than for the other codecs (High Definition Sound Performance).

Gigaset S67H, S68H, SL37H and A58H are examples of HDSP-compatible handsets.

G.711 a law / G.711 μ law

Excellent voice quality (comparable with ISDN). The necessary bandwidth is 64 kbit/s per voice connection.

G.726 Good voice quality (inferior to that with G.711 but better than with G.729).

Your phone supports G726 with a transmission rate of 32 kbit/s per voice connection.

G.729 Average voice quality. The necessary bandwidth is less than or equal to 8 kbit/s per voice connection.

Both parties involved in the telephone connection (caller/sender and recipient side) must use the same voice codec. The voice codec is negotiated between the sender and the recipient when establishing a connection.

You can influence the voice quality by selecting (bearing in mind the bandwidth of your DSL connection) the voice codecs your phone is to use, and specifying the order in which the codecs are to be suggested when a VoIP connection is established.

Area: Settings for Bandwidth

The settings in this area influence all VoIP connections (VoIP phone numbers).

Allow 1 VoIP call only

You can usually make two VoIP calls at the same time on your phone. If, however, your DSL connection has a narrow bandwidth, there may be problems if two VoIP calls are made at the same time. The data is no longer transferred properly (long voice delay, data losses, etc.).

- ▶ Select **Yes** next to **Allow 1 VoIP call only** to prevent any further parallel VoIP phone connections being established.
- ▶ If you wish to permit two VoIP connections, select **No**.

Please note

If only one VoIP connection is permitted, the following VoIP network services will **no** longer be available:

- ◆ Call waiting is not displayed during a call via VoIP.
 - ◆ External consultation call from a VoIP call
 - ◆ Call swap and initiating a conference call via VoIP
-

Voice Quality

Default settings for the codecs used are stored in your phone: one setting optimized for narrow and one for wide bandwidths.

- ▶ Activate one of the options **Optimized for low bandwidth / Optimized for high bandwidth** if you wish to accept a default setting for all VoIP connections. The settings are shown in the **Settings for Connections** area and cannot be changed.
- ▶ Activate the **Own Codec preference** option if you wish to select and set connection-specific voice codecs yourself (see "**Area: Settings for Connections**").

Area: Settings for Connections

In this area you can make specific settings for each of your VoIP phone numbers.

You can make the following settings for each VoIP phone number configured on your phone:

Volume for VoIP Calls

Depending on the VoIP provider, it is possible that the received handset/earpiece volume is too low or too high, so that adjusting the volume via the handset is not adequate.

Specify whether the received volume range is too high or too low. The following options are available:

Low

Handset/earpiece volume is too high. Activate this option to reduce the volume by 6 dB.

Normal

The handset/earpiece volume does not need to be raised/lowered.

High

Handset/earpiece volume is too low. Activate this option to increase the volume by 6 dB.

Setting the phone with the PC

Voice codecs

Prerequisite: The **Own Codec preference** option is activated for the **Voice Quality** in the **Settings for Bandwidth** area.

Select the voice codecs your phone is to use, and specify the order in which the codecs are to be suggested when a VoIP connection is established via this VoIP phone number.

- ▶ Apply the voice codecs that your phone is to suggest for outgoing calls into the **Selected codecs** list.
To do this, in the **Available codecs** list select the voice codec that you want to apply (you can mark several entries using the Shift key or the Ctrl key). Select **<Add**.
- ▶ Move the voice codecs that you do not want the phone to use into the **Available codecs** list.
Select the voice codecs in the **Selected codecs** list (see above) and click the **Remove>** button.
- ▶ Sort the voice codecs in the **Selected codecs** list into the order in which they should be suggested to the receiving device when a connection is established. To do this, use the **Up** and **Down** buttons.

When establishing a VoIP connection, the phone suggests the 1st voice codec in the **Selected codecs** list to the receiving device to begin with. If the receiving device does not accept this voice codec (e.g. because it is not supported), the 2nd voice codec on the list is suggested, and so on.

If the receiving device does not accept any of the voice codecs in the **Selected codecs** list, the connection is **not** established. An appropriate message is displayed on the handset.

If the phone always starts by trying to establish a broadband connection, put the **G.722** codec at the top of the **Selected codecs** list.

Please note

- ◆ Only deactivate codecs (put them in the **Available codecs** list) if there is a particular reason. The more codecs that are deactivated increases the risk of calls not being established due to unsuccessful codec negotiations. In particular you can only establish broadband connections if you permit the **G.722** codec.
 - ◆ With incoming calls, all supported voice codecs are always permitted.
-

Area: Settings for Codecs

To save additional bandwidth and transmission capacity, on VoIP connections that use the **G.729** codec you can suppress the transmission of voice packets in pauses ("Silence Suppression"). Then, instead of the background noises in your environment, your caller hears a synthetic noise generated in the receiver.

Please note: "Silence Suppression" can sometimes lead to deterioration in the voice quality.

- ▶ In the **Enable Annex B for codec G.729** field, state whether the transmission of data packets during pauses should be suppressed when using the **G.729** codec, (select **Yes**).

Saving settings on the phone

- ▶ Select **Set** to save the settings for the voice quality.

Please note

Please observe the following for good voice quality:

- ◆ When making calls using VoIP, avoid performing other Internet activities (e.g. surfing the Internet).
 - ◆ Please note that voice delays can occur depending on the codec used and the network capacity utilization.
-

Voice quality and infrastructure

With your Gigaset S675 IP, you have the opportunity to make calls with good voice quality via VoIP.

However, your phone's performance with VoIP – and therefore the voice quality – also depends on the properties of the entire infrastructure.

The following VoIP provider components are just some of the things that can influence performance:

- ◆ Router
- ◆ DSLAM
- ◆ DSL transmission line and speed
- ◆ Connection paths over the Internet
- ◆ If applicable, other applications that also use the DSL connection

In VoIP networks, voice quality is affected by various things including the "Quality of Service" (QoS). If the entire infrastructure demonstrates QoS, voice quality is higher (fewer delays, less echoing, less crackling, etc.).

If, for example, the router does not have QoS, then the voice quality is not as good. Please see the specialist documentation for further information.

Setting the telephone's default connection

The default telephone connection defines which line type (VoIP or fixed line network) is used to dial numbers when you **briefly** press the  Talk key. The default connection is applied to all registered handsets.

- ▶ Open the following Web page: **Settings** → **Telephony** → **Number Assignment**.

Area Default Connection

- ▶ Select the default connection for your phone. This can be done by selecting option **VoIP** or **Fixed Line** after **Linetype for outgoing calls**.
- ▶ Select **Set** to activate your settings.

Please note

- ◆ The default connection is only relevant when dialing numbers that are not subject to dialing plans and are entered without a line suffix.
 - ◆ You can change the settings for the default connection via any registered handset (→ [Page 134](#)).
-

Setting the phone with the PC

Activating the fixed line network connection as an alternate connection

You can activate the fixed line network connection on your phone as an alternate connection. If an attempt to establish a connection via VoIP then fails, an attempt is made automatically to establish the connection via the fixed line network.

An alternate connection would be used in the following cases:

- ◆ Your VoIP connections are busy.
- ◆ The SIP server for the VoIP connection cannot be accessed.
- ◆ The dialed VoIP connection has not (yet) been configured correctly (e.g. incorrect password).
- ◆ The base station does not have a connection to the Internet, e.g. because your router is deactivated or not connected to the Internet.

Exceptions

If a URI or IP address is dialed instead of a phone number, the connection cannot be created via the fixed line network.

- ▶ Open the following Web page: **Settings** → **Telephony** → **Number Assignment**.

Area Default Connection

- ▶ To activate the fixed line network connection as an alternate connection, click the **Yes** option next to **Automatic Fallback to Fixed Line**. Select **No** to deactivate the function.
- ▶ Select **Set** to activate your settings.

Assigning send and receive numbers to handsets

You can assign up to eight phone numbers on your phone: your fixed line network number, your Gigaset.net number and up to six VoIP numbers.

You can assign as many of these numbers as you like to each handset as receive numbers. Receive numbers determine which handset(s) will ring when a call is received.

You can assign one of your VoIP numbers to each handset as a (VoIP) send number. Send numbers define which VoIP account should be used generally to make and pay for outgoing VoIP calls. **Exceptions:**

- ◆ A phone number is dialed with a line suffix (→ [Page 155](#)) or
- ◆ A dialing plan has been defined for the phone number (→ [Page 172](#)).

The Gigaset.net number and fixed line network number are permanently assigned to each registered handset as send numbers.

Setting the phone with the PC

Please note

A handset is assigned the following numbers after it is registered on the base station:

- ◆ Receive numbers: all phone numbers assigned to the phone (fixed line network, Gigaset.net and VoIP).
- ◆ Send numbers: the fixed line network number and the VoIP phone number that you entered at the start of the phone configuration.

▶ Open the following Web page: **Settings** → **Telephony** → **Number Assignment**.

The display shows all registered handsets. A list is displayed for each handset showing the phone numbers that are configured and activated for the phone. The connection names are shown in the column **Connections**. The fixed line network connection is always at the end of the list.

▶ Define a VoIP phone number as the send number for each handset. To do this, click the option following the phone number in the **for outgoing calls** column. The previous assignment will automatically be deactivated.

Please note

The fixed line network number is permanently assigned to each handset as a send number. This assignment cannot be deactivated. It ensures that emergency numbers can be called from every handset.

The Gigaset.net number is also permanently assigned to each handset.

-
- ▶ Select the phone numbers for each handset (fixed line network, VoIP) that are to be assigned to the handset as receive numbers. To do this, click the option following the phone number in the **for incoming calls** column. Every handset can be assigned several phone numbers or no phone number (= assigned).
 - ▶ Select **Set** to save your settings.

Please note

- ◆ If a VoIP phone number that has been assigned to a handset as a send number is deleted, the handset will automatically be assigned the first configured VoIP phone number.
 - ◆ Calls made to a number that is not assigned to a handset as a receive number will not be signaled on any handset.
 - ◆ If you have not assigned receive numbers to any of the handsets, calls to all connections are signaled on all handsets.
-

Setting the phone with the PC

Assigning receive numbers to the answering machine

You can specify for which of your phone numbers your telephone's answering machine is to accept calls. To do this, assign receive numbers to the answering machine.

Please note

- ◆ Once the new entry has been made, each VoIP phone number is assigned to the integrated answering machine as a receive number.
 - ◆ If no receive number is assigned to the answering machine, it will not accept any calls – even if it is activated.
 - ◆ For details of how to set and operate the answering machine, → [Page 96](#).
- ▶ Open the following Web page: **Settings** → **Telephony** → **Number Assignment**.
 - ▶ In the **Answering machine** area, select the phone numbers (fixed line network, VoIP) for which the answering machine is to accept calls (if it is activated, → [Page 97](#)). To do this, click the option following the phone number in the **for incoming calls** column. You can assign as many numbers as you wish to the answering machine (= assigned).
 - ▶ Select **Set** to save your settings.

Activating Call Forwarding for VoIP connections

You can forward calls to your VoIP numbers and to your Gigaset.net number.

You can forward calls to your VoIP numbers to any external number (VoIP, fixed line or cellular network number). The forwarding is done via a VoIP connection.

You can forward calls to your Gigaset.net number within the Gigaset.net, i.e. to another Gigaset.net number.

You can define if and when calls to your Gigaset.net number and some of your VoIP numbers (VoIP account) should be forwarded to this VoIP number.

You can also use the handset to define call forwarding and activate/deactivate it, → [Page 61](#).

- ▶ Open the following Web page: **Settings** → **Telephony** → **Call Forwarding**.

The display shows a list of all your configured VoIP connections and your Gigaset.net number.

Connections

Select the name you have assigned to the VoIP number, or select **Gigaset.net**.

When

Select when a call to this VoIP number should be forwarded:
When busy / No reply / Always. Select **Off** to deactivate call forwarding.

Call number

Enter the phone number to which the calls should be forwarded. Please note that you may have to enter the area code when forwarding to a fixed line network number in the same area (depending on your VoIP provider and the setting for the automatic area code → [Page 171](#)).

The settings only affect the phone number selected in **Connections**.

Entering your own area code, activating/deactivating an automatic area code for VoIP

On the base station, save the complete code (with international code) for the area in which you are using the phone.

For VoIP calls you must generally always dial the area code – even for local calls. You can avoid having to dial the area code for local calls by setting your phone to prefix this code for all VoIP calls made in the same local area (→ option **Predial area code for local calls through VoIP**).

For calls made via VoIP, the area code entered is then prefixed to all numbers that do not begin with 0 – even when dialing numbers from the directory and other lists.

Exceptions: Phone numbers for which you have defined dialing plans and deactivated the **Use Area Codes** (→ **Page 172**) option.

When making calls via the fixed line network, the area code entered is withheld, e.g. when dialing using the Calls list (→ **Page 67**).

Please note

For information on how to enter your area code via the handset, → **Page 135**

- ▶ Open the following Web page: **Settings** → **Telephony** → **Dialing Plans**.

Area Area Codes

Make the following settings here:

- ▶ From the **Country** list, select the country in which you are using your phone. This way the country code and the prefix of the area code are automatically set (in **International Prefix / Area Code** and **Local Prefix** fields).
- ▶ In the **Local Area Code** field, enter the area code for your town/city without a prefix (maximum 8 characters 0–9, *, #, R, P, r, p), e.g. 617 (for Boston).
- ▶ Select **Yes** next to **Predial area code for local calls through VoIP** to activate the function.
Select **No** to deactivate the function. You will then need to enter the area code for local calls made via VoIP. Numbers in the directory must always contain the area code when dialing via VoIP.
- ▶ Select **Set** to save the settings.

Please note

- ◆ The area code will also be prefixed to VoIP calls made to emergency numbers if there are **no** defined dialing plans for these numbers.
 - ◆ The numbers of your network mailbox saved in the base station are **not** prefixed with an area code (→ **Page 174**).
-

Setting the phone with the PC

Defining dialing plans – cost control

You can define dialing plans to reduce costs:

- ◆ You can define the connection (one of your VoIP accounts, the fixed line network) through which calls to specific numbers should be made and paid for. If you enter just a few digits (e.g. local area, national or cellular network code), any call to a number beginning with these digits is made via the elected connection.
- ◆ You can block specific numbers, i.e. your phone will not establish a connection to these numbers (e.g. 1900 numbers).

These dialing plans apply to all registered handsets. The settings for the default connection (briefly press/press and hold ) and the send numbers of handsets do not apply to numbers governed by a dialing plan.

Please note

You can override dialing plans, with the exception of blocks, as follows:

- ◆ Dial the number with a line suffix (e.g. 123456789#3, → [Page 47](#)).
 - ◆ Before entering the number, define another connection type by pressing the **Phone** or **IP** Display key (→ [Page 124](#)).
If, for example, you press **Phone**, the number is dialed via the fixed line network, even if the dialing plan states that a VoIP connection should be used.
-

Tips:

- ◆ Compare the rates for long-distance calls (especially for international calls) offered by your fixed line network and VoIP providers, and determine which connection should be used specifically for these countries/locations, e.g. a dialing plan for the **Phone Number** "01133" would apply to every call made to France.
- ◆ Use dialing plans to define that numbers starting with a call-by-call number are always made via your fixed line network connection. To do so, enter the call-by-call number in the **Phone Number** field.

Defining dialing plans

- ▶ Open the following Web page: **Settings** → **Telephony** → **Dialing Plans**.

Area Dialing Plans

Specify dialing plans for your phone. Specify the following:

Phone Number

Enter the number or the first digits of the phone number (e.g. an area code) to which the dialing plan should apply (maximum 15 digits).

Use Area Codes

Activate this option if the area code is to be added automatically for all calls via VoIP for the phone number in **Phone Number** or all phone numbers that begin with the digits in **Phone Number** (→ [Page 171](#)).

Connection Type

The list shows all the VoIP connections that you have configured as well as your fixed line network connection. It also displays the name assigned to each connection.

- ▶ From the list, select the connection via which the number or numbers that start with the specified sequence of digits should be dialed.

Or:

- ▶ Select **Block** if the number or numbers that start with the sequence of digits should be blocked.

The display will show **Not possible** if an attempt is made to dial a blocked number.

Comment (optional)

You can enter a description of the dialing plan here (maximum of 20 characters).

- ▶ Select **Add**.

The dialing plan is activated immediately.

A new empty line for a new dialing plan will appear if your phone still has enough space to add further plans.

Please note

If dialing plans overlap, the one with the greatest concordance will apply.

Example:

There is a dialing plan for the number "21" and one for the number "217". If you dial "2171..." the second plan will apply; if you dial "2101..." the first plan will apply.

Examples

- ◆ You want to block your phone for all 1900 numbers.

Dialing plan:

Phone Number = 0190 **Connection Type** = **Block**

- ◆ All calls to the cellular phone network should be made via your VoIP connection with provider B.

Dialing plans:

Phone Number = 020 **Connection Type** = **IP3**, provider B

and the corresponding entries for "030" and "040", etc.

Activating/deactivating dialing plans

- ▶ Select the option in the **Active** column to activate/deactivate the corresponding dialing plan (= activated).

A deactivated dialing plan will not take effect until it is reactivated.

Setting the phone with the PC

Deleting dialing plans

- ▶ Select **Delete** next to the dialing plan you wish to delete.

The dialing plan is deleted from the list immediately. The space in the list is released.

Please note

Predefined dialing plans set as defaults (for emergency numbers) **cannot** be deactivated and **cannot** be deleted.

Emergency numbers

Dialing plans for emergency numbers (e.g. the **local** emergency service number) are preset for certain countries. The fixed line network is determined as the **Connection Type**.

These dialing plans cannot be deleted, deactivated or blocked. However, you can change the **Connection Type**.

This should only be changed if the phone is not connected to the fixed line network. If you choose a VoIP connection, please make sure the VoIP provider supports calls to emergency numbers. If the VoIP connection is deleted from the configuration, the emergency call can no longer be made.

If no emergency numbers are set by default, define dialing plans for emergency numbers yourself and assign them to a connection that you know supports emergency calls. Deactivate the **Use Area Codes** option for these dialing plans. Calls to emergency numbers are always supported by fixed line networks.

Warning

- ◆ Emergency numbers cannot be dialed if the keypad lock is activated. Before dialing, press **and hold** the Pound key (**#**), to release the keypad lock.
 - ◆ If you have activated an automatic area code (→ [Page 171](#)) and if no dialing plan for emergency numbers is defined, the area code will also be prefixed to emergency calls made via VoIP.
-

Activating/deactivating network mailbox, entering numbers

Many fixed network providers and VoIP providers offer answering machines on the network – these are known as network mailboxes.

Each network mailbox accepts incoming calls made via the corresponding line (fixed line network or corresponding VoIP phone number).

You can enter the relevant network mailbox for each configured connection (VoIP, fixed line network) via the Web configurator. You can activate or deactivate the network mailbox for your VoIP connections.

- ▶ Open the following Web page: **Settings** → **Telephony** → **Network Mailbox**.

A list with all possible connections is displayed on the Web page. The names of the connections are displayed in the **Connection** column.

Entering numbers

- ▶ Enter the network mailbox number in the **Call number** column after the desired connection.

With some VoIP providers your mailbox number is downloaded together with the general VoIP provider data (→ [Page 157](#)), saved to your base station and displayed under **Call number**.

- ▶ Select **Set** to save your settings.

Activating/deactivating the network mailbox

- ▶ You can activate () and deactivate () individual network mailboxes using the option in the **Active** column. Activating/deactivating is carried out by selecting the appropriate option. The change does not need to be saved.

Please note

- ◆ You need to have **requested** the network mailbox for your fixed line network connection from your fixed line network provider.
 - ◆ For details of how to enter the network mailbox numbers and activate/deactivate network mailboxes, please see [Page 106](#).
-

Setting DTMF signaling for VoIP

DTMF signaling is required, for example, for querying and controlling certain network mailboxes via digit codes or for remote operation of the local answering machine.

To send DTMF signals via VoIP you must first define how key codes should be converted into and sent as DTMF signals: as audible information via the speech channel or as a "SIP Info" message.

Ask your VoIP provider which type of DTMF transmission it supports.

- ▶ Open the following Web page: **Settings** → **Telephony** → **Advanced Settings**.

Area DTMF over VoIP connections

Make the required settings for sending DTMF signals.

- ▶ Activate **Audio** or **RFC 2833**, if DTMF signals are to be transmitted acoustically (in voice packets).
- ▶ Activate **SIP Info** if DTMF signals are to be transmitted as code.
- ▶ Select **Set** to save your settings.

Please note

- ◆ The settings for DTMF signaling apply to all VoIP connections (VoIP accounts).
 - ◆ DTMF signals cannot be transmitted in the audio path (**Audio**) on broadband connections (the G.722 codec is used).
-

Setting the phone with the PC

Defining Flash key functions for VoIP (hook flash)

Your VoIP provider may support special performance features. To make use of these features, your phone needs to send a specific signal (data packet) to the SIP server. You can assign this "signal" to your phone's Flash key.

If you press the Flash key during a VoIP call the signal is sent to the server.

Prerequisite:

- ◆ DTMF reminders via SIP info messages is activated, i.e. the option **SIP Info** on this Web page is activated (→ [Page 175](#)).
- ◆ The  key is not used for call forwarding, i.e. **Use the R key to initiate call transfer with the SIP Refer method.** = **No** is set for call forwarding (→ [Page 176](#)).

If one of these prerequisites is not fulfilled, the field in the **Hook Flash (R-key)** area is hidden.

- ▶ Open the following Web page: **Settings** → **Telephony** → **Advanced Settings**.

Area Hook Flash (R-key)

- ▶ In the **Application Type** fields, (maximum 31 characters) and **Application Signal** fields (maximum 15 characters) enter the data that you have received from your VoIP provider.
- ▶ Select **Set** to save your settings.

The setting for the Flash key applies to all registered handsets.

Configuring call forwarding via VoIP

If you are swapping calls via VoIP connections, you can connect the two external callers (provider-dependent). You can configure settings for this type of call forwarding.

- ▶ Open the following Web page: **Settings** → **Telephony** → **Advanced Settings**.

Area Call Transfer

- ▶ Make your settings for call forwarding via VoIP in the following fields:

Use the R key to initiate call transfer with the SIP Refer method.

If you activate the **Yes** option, the two external parties you are swapping between are connected when you press the End Call key . Your connections with the callers are terminated.

Transfer Call by On-Hook

If you select **Yes**, the external parties you are swapping between is connected when you press the End Call key . Your connections with the callers are terminated.

Preferred Refer To

Define the protocol (the contents of the "Refer To" information) that should be used with preference when forwarding calls:

Target's contact info

This protocol is recommended for "closed" networks (internal company and business networks).

Original URL

This protocol is recommended when the base station is connected to the Internet via a router with NAT.

Automatic Refer To

If you select **Yes**, the base station will automatically attempt to determine the best protocol.

If the base station cannot determine the best protocol, it will use the protocol defined in **Preferred Refer To**.

- ▶ Select **Set** to save your settings.

Please note

For information on how to forward a call when you deactivate both **Use the R key to initiate call transfer with the SIP Refer method.** and **Transfer Call by On-Hook**,
→ [Page 63](#).

Defining local communication ports for VoIP

Specify which local communication ports (port numbers) the telephone is to use for VoIP telephony. The ports must not be used by any other subscriber in the LAN.

The following communication ports are used for VoIP telephony:

- ◆ **SIP port**

Communication port via which the phone receives (SIP) signaling data

- ◆ **RTP port**

Two consecutive RTP ports (consecutive port numbers) are required for each VoIP connection. Voice data is received via one port and control data via the other.

You can set port numbers or port number areas for SIP and RTP ports, or set your telephone so that it can use any number of free ports from a predefined range of port numbers.

- ▶ Open the following Web page: **Settings** → **Telephony** → **Advanced Settings**.

Setting the phone with the PC

Area Listen ports for VoIP connections

Use random ports

Click **No** if you want the phone to use the ports specified in the fields **SIP port** and **RTP port**.

Click **Yes** if you do not want the phone to use fixed ports for **SIP port** and **RTP port**, but rather to use any free ports from predefined ranges of port numbers. The use of random ports makes sense if you want several phones to be operated on the same router with NAT. The phones must then use different ports so that the router's NAT is only able to forward incoming calls and voice data to one (the intended) phone.

Use random ports = No

SIP port Specify the port number for the SIP port. Enter a number between 1024 and 49152 in the field.

The default port number for SIP signaling is 5060.

The port number specified must not be in the **RTP port** number range.

RTP port Specify a range of port numbers that are to be used as RTP ports. This range must be used in the LAN (router) for the phone.

Enter the lowest port number in the left-hand field and the highest number in the right-hand field (numbers between 1024 and 55000).

Size of the port number range:

The difference between the port numbers must be at least **6** if you permit two simultaneous VoIP calls on your phone. The difference must be at least **4** if you only permit one VoIP call (→ option **Allow 1 VoIP call only** on **Page 164**).

The lower of the port numbers in the range (in the left-hand field) must be an **even** number. If you enter an odd number, the next lower even number is selected automatically (e.g. if you enter 5003, then 5002 is set automatically).

The default port number for voice transmission is 5004.

Use random ports = Yes

SIP port Enter the port number range from which the SIP port is to be selected.

Specify the lowest port number in the left-hand field and the highest number in the right-hand field (number between 1024 and 49152).

This port number range must not overlap the range specified for **RTP port**.

The default range is 5060 to 5076.

RTP port Specify a range of port numbers from which the RTP ports are to be selected.

Specify the lowest port number in the range in the left-hand field and the highest number in the right-hand field.

The default range is 5004 to 5020.

▶ Select **Set** to save your settings.

Saving messenger access data

The messenger client in your base station enables **instant messaging** (immediate message transfer, chatting). The phone supports the XMPP messenger (Jabber).

In order for you to use your phone's messenger to "go online" and "chat" on the Internet, the access data of a message server must be saved on your phone.

Your phone is already registered with the Gigaset.net Jabber server. An account has been assigned to your phone. You can chat to other Gigaset.net subscribers via this account. To do this you need to create a buddy list on the PC (→ "**Setting up a Gigaset.net Jabber account**" on **Page 180**).

You can also register with another instant messaging provider that supports XMPP Messenger (Jabber). You must then save the message server address and your access data on your phone.

You can define a **Resource** name and a **Priority** for your phone. Both are required if you are logged in (online) with the message server with several devices (phone, desktop PC and laptop) at the same time using the same Jabber ID.

The **Resource** name is used to distinguish between these devices. The phone cannot log in to the message server if it does not have a resource name.

Assign a **Priority** as each message will only be sent to one device for each Jabber ID. The **Priority** determines which of the devices receives the message.

Example

You are online using one of your phone's handsets and your PC both at the same time. You have assigned your phone (**Resource** name "phone") **Priority** 5 and your PC (**Resource** name "PC") priority 10. In this case, any message addressed to your Jabber ID is sent to your phone.

- ▶ Open the following Web page: **Settings** → **Messaging** → **Messenger**.
- ▶ In the **Messenger Account** field, select whether you wish to use the **Gigaset.net** Jabber server or another provider's message server (**Other**).
The access data for **Gigaset.net** is already stored in the base station. It is displayed in **Jabber ID**, **Authentication password** and **Jabber server**. With this data you can also register with the Gigaset.net Jabber server through your PC.
- ▶ Enter the user ID (maximum 50 characters) and password (maximum 20 characters) that you used to register with the message server in the **Jabber ID** and **Authentication password** fields. If you have selected **Messenger Account = Gigaset.net**, the fields are preset with your Gigaset.net account.
- ▶ In the **Jabber server** field, enter the IP address or the DNS name of the message server with which you are registered for instant messaging.
Max. 74 alphanumeric characters.
If you have selected **Messenger Account = Gigaset.net**, the field is preconfigured with the name of the Gigaset.net server.

Setting the phone with the PC

- ▶ Enter the number of the communication port on the Jabber server in the **Jabber server port** field. The default port is 5222.
If you have selected **Messenger Account = Gigaset.net**, the port number is pre-configured.
- ▶ Enter a resource name (maximum 20 characters) in the **Resource** field.
The default is **phone**.
- ▶ Enter the priority for your phone in the **Priority** field. Select a number between -128 (highest priority) and 127 (lowest priority) for the priority.
The default is: 5
- ▶ Select **Set**.

Setting up a Gigaset.net Jabber account

Your phone is already registered with the Gigaset.net Jabber server. An account has been assigned to your phone.

To chat with other Gigaset.net subscribers via this account, you must transfer the required Gigaset.net subscribers to a Contact list (Buddy list) on your PC. You can use any conventional Jabber client for this (e.g. PSI, Miranda; see e.g. <http://www.swissjabber.ch>).

Do the following to use your Gigaset.net Jabber account:

- ▶ Start the Web configurator, open the **Settings → Messaging → Messenger Web** page and select the **Messenger Account Gigaset.net** field. Your account data is displayed in **Jabber ID** and **Authentication password**. You will need these to create a Buddy list via the Jabber client on the PC.
- ▶ Start your Jabber client on the PC.
- ▶ Enter your Gigaset.net **Jabber ID** on the Jabber client as a new account. The **Jabber ID** consists of your Gigaset.net number and "@jabber.gigaset.net"
Example: 12345678901#9@jabber.gigaset.net
- ▶ Then enter your **Authentication password**.

Please note

- ◆ Do **not** select the option "Create new account". Your Gigaset.net Jabber account has already been created in Gigaset.net.
 - ◆ The option "SSL connection" must be **deactivated** in the Jabber client.
-

- ▶ Now you can enter Gigaset.net subscribers as contacts (buddies).
For the Jabber ID of each subscriber, enter the subscriber's Gigaset.net number with "@jabber.gigaset.net" (example: 2141524901#9@jabber.gigaset.net).

A request to "Add to Contact list" is sent to the subscriber.

If the subscriber accepts this request, they are added to your Buddy list. This updated buddy list is displayed on the handset the next time the messenger is rebooted. To restart: If necessary, close your connection to the message server (→ [Page 84](#)) and then go back online (→ [Page 82](#)).

Please note

For details of how to use your handset to go online and chat with or call buddies, → [Page 81](#).

Configuring incoming e-mail

You can use your phone to be notified about new e-mail messages on your incoming e-mail server and display the incoming mail list and the text of the e-mail messages on the handset (→ [Page 77](#)).

You must store the address or DNS name of your incoming e-mail server and your personal access data in the phone and activate the e-mail check with the incoming e-mail server, so that the phone can establish a connection to the incoming e-mail server and connect to your mailbox.

- ▶ Open the following Web page: **Settings** → **Messaging** → **E-Mail**.
- ▶ Enter the user name (account name) agreed with the Internet provider (maximum 74 characters) in the **Authentication Name** field.
- ▶ Enter the password agreed with your provider for accessing the incoming e-mail server (maximum 32 characters; case sensitive) in the **Authentication password** field.
- ▶ Enter the name of the incoming e-mail server (POP3 server) (maximum 74 characters) in the **POP3 Server** field. Example: pop.theserver.com.
- ▶ Select from the **Check for new e-mail** list the time interval at which your phone should check whether new messages have arrived in your incoming e-mail server. Select **Never** to deactivate the request. Select one of the other values to activate the prompt for new e-mail messages.
- ▶ Select the **Set** button to save the settings in your phone.

Please note

For details of how you can display e-mail notifications on your handset and open e-mails to read, → [Page 77](#).

Configuring info services/activating idle display

You can configure your handset to display customized text information (e.g. weather reports, news feeds, E-bay messages, traffic reports) in the idle display. To do this you must set the **Clock** screensaver on the handset (→ [Page 123](#)).

Configuring info services

Please note

The weather report is preset. It is shown in the handset's idle display as soon as you set the **Clock** as a screensaver.

- ▶ Open the following Web page: **Settings** → **Services**.

Setting the phone with the PC

Area Info Services Configuration

- ▶ Click the link.

www.gigaset.net/myaccount

The Web page for Gigaset.net info services is opened. You are now registered with your Gigaset.net user ID. Your Gigaset.net user ID and password are displayed in the **Info Services Configuration** area of the Web configurator **Services** page.

This will open a website where you can compile your info service.

- ▶ Define which information should be sent regularly to your handset.

Activating display info services

- ▶ Open the following Web page: **Settings** → **Services**.

Area Activate Info Services

- ▶ In the area, select **Yes / No** to activate or deactivate the display of text information.
- ▶ Select the **Set** button to save the settings in your phone.

If text information is available it is displayed (in idle display) on all registered Gigaset S67H/S68H, SL37H or C47H handsets for which the digital clock is set as the screensaver.

The text information overwrites the digital clock.

Please note

On the Gigaset A58H and C38H handsets you can activate/deactivate the info services by activating/deactivating the corresponding screensaver on the handset. The setting in the **Activate Info Services** area has no effect on how these handsets behave.

Changing internal handset numbers and names

Each handset is **automatically** assigned an internal number (1 to 6) and an internal name ("INT 1", "INT 2", etc.) when it registers with the base station (→ [Page 113](#)).

The internal numbers and names of all registered handsets can be changed.

Please note

For information on how to change internal names and numbers, → [Page 115](#).

- ▶ Open the following Web page: **Settings** → **Handsets**.

In the Registered Handsets area

The names and internal numbers of all registered handsets are displayed.

- ▶ Select the handset whose number/name you want to change.
- ▶ **Changing numbers:** Select the internal number that you want to assign to the handset in the **No.** column of the handset. If a handset with this internal number already exists, you will also have to change the number assigned for this handset. The internal numbers 1-6 can only be assigned once each.
- ▶ **Changing names:** If necessary, change the name of the handset in the **Name** column. The name may contain up to 10 characters.
- ▶ If necessary, repeat the process for other handsets.
- ▶ Select **Set** to save the settings.

The changes are saved in the internal lists of all registered handsets. Handsets are sorted by their internal numbers in the internal list. The order of the handsets in the list can be changed.

Please note

If you have entered an internal number twice, a message will appear. The internal numbers are not changed.

Transferring handset directories to/from the PC

The Web configurator has the following options for editing the directories of the registered handsets.

- ◆ Store the handset directories on a PC. Entries are stored in vCard format in a vcf file on the PC. You can edit these files with an ASCII editor (e.g. Notepad/Editor in Windows Accessories) and load them onto any registered handset. You can also transfer directory entries to your PC address book (e.g. Outlook Express™ address book).
- ◆ Transfer contact details from your PC address book to handset directories. Export the contacts, e.g. with Outlook Express™ to vcf files (vCards) and transfer them to handset directories using the Web configurator.
- ◆ Delete the directory on the handset. If you have edited the directory file (vcf file) on the PC and would like to use this modified directory on the handset, you can delete the current directory from the handset first.

Tip: Back up the current directory on your PC before deleting it. You can then reload it onto the handset if the modified directory is affected by formatting errors and some, or all, of it cannot be loaded onto the handset.

Please note

- ◆ You can find information on the vCard format (vcf) on the Internet, e.g. at: www.en.wikipedia.org/wiki/VCard or www.de.wikipedia.org/wiki/VCard (You can set the display language at the bottom left-hand side in the navigation area of the Web page.)

To transfer a handset directory (vcf file) saved on the PC that contains numerous entries to a Microsoft Outlook™ address book, be aware that Microsoft Outlook™ only transfers the first (directory) entry from the vcf file to its address book.

Setting the phone with the PC

Prerequisites:

- ◆ The handset can send and receive directory entries.
- ◆ The handset is activated and is in idle status.
- ▶ Open the following Web page: **Settings** → **Handsets**.

The names of all registered handsets are displayed in the **Directory** area.

- ▶ Select the handset for which you want to save or edit the directory. To do this, click on the option before the handset.

Loading the directory file from the PC to the handset

- ▶ In the **Transfer directory to handset** area, specify the vcf file you want to load on to the handset (complete path name), or select **Browse...** and navigate your way to the file.
- ▶ Select **Transfer** button to start the transfer.

The display will show how many of the entries from the vcf file are being transferred to the directory.

Transfer rules

The directory entries from a vcf file that are loaded onto the handset are added to the directory. If an entry already exists for a name, it will either be supplemented or a new entry for the name is created. The process will not overwrite or delete any phone numbers.

Please note

Depending on your handset type, up to three entries with the same name is created in the handset directory for each vCard – one entry per entered number.

Loading the directory from the handset to the PC

- ▶ Select **Save** in the **Handset Directory** area. A Windows dialog box is shown to save the file.
- ▶ Enter the directory on the PC (complete path name) in which the directory file is to be stored. Select **Save** or **OK**.

Deleting the directory

- ▶ Select **Delete** in the **Handset Directory** area.
- ▶ Confirm the security prompt **Telephone directory of the selected handset will be deleted. Continue?** with **OK**.

All directory entries are deleted.

Please note

For how to delete the directory on the handset, → [Page 73](#).

Directory file content (vcf file)

The following data (if available) is written into the vcf file for entry into the directory or transferred from a vcf file into the handset directory.

Setting the phone with the PC

- ◆ Name
- ◆ First name
- ◆ Number
- ◆ Number (office)
- ◆ Number (cell)
- ◆ E-mail address
- ◆ Date (YYYY-MM-DD) and time of the reminder call (HH:MM) separated by a "T" (example: 2008-01-12T11:00).
- ◆ Identification as VIP (X-SIEMENS-VIP:1)

Other information that a vCard may contain is not entered into the handset directory.

Example for an entry in vCard format:

```
BEGIN:VCARD
VERSION:2.1
N:Smith;Anna
TEL;HOME:1234567890
TEL;WORK:0299123456
TEL;CELL:0175987654321
EMAIL:anna@smith.com
BDAY:2008-12-24T11:00
X-SIEMENS-VIP:1
END:VCARD
```

Activating VoIP status message display

You can display VoIP status messages on your handset when there are VoIP connection problems. These messages give you information on the status of a connection and contain a provider-specific status code that helps the service team when they are analyzing the problem.

- ▶ Open the following Web page: **Settings** → **Handsets**.

Area VoIP Status

- ▶ Select **Yes** after **Show VoIP status on handset** to activate the status message display.
If you select **No**, no VoIP status messages are displayed.
- ▶ Select **Set** to save the changes.

Please note

This user guide contains a table with possible status codes and their definitions, → [Page 194](#).

Starting a firmware update

If necessary, you can load updates of the base station firmware onto your phone.

Setting the phone with the PC

The server on which Gigaset Communications makes new firmware versions available for your base station is set by default. The URL of the Internet server is displayed in the **Data server** field.

Only change this URL when requested by Customer Care. This address is also used to load provider information from the Internet. Make sure you write down the default URL exactly before changing it. Otherwise, you will only be able to reactivate the default URL by resetting the base station back to the default settings (→ [Page 133](#)).

Please note

- ◆ When updating from the Internet, checks are made to ensure that no **newer** version of the firmware exists. If this is not the case, the operation is terminated.
 - ◆ The firmware is only loaded from the Internet if you have not entered a local file in the **User defined firmware file** field prior to the update.
-

Prerequisites:

- ◆ No calls are being made via the fixed line network or VoIP.
- ◆ There is no internal connection between registered handsets or to GHC devices.
- ◆ The base station menu is not open in any of the handsets.
- ▶ Open the following Web page: **Settings** → **Miscellaneous**.
- ▶ Select the **Update Firmware** button.

The firmware is updated. This process can take up to three minutes.

Please note

You can also start the firmware update on the handset (→ [Page 136](#)).

Firmware update from local firmware file

In extraordinary circumstances you may receive, for example, a firmware file from Service that you can upload from your PC to your telephone (e.g. because the firmware update via the Internet did not work).

Prerequisite: A Web server is running on the local PC (e.g. Apache).

- ▶ First load the firmware file onto your PC.
- ▶ In the **User defined firmware file** field enter the IP address of the PC in your local network and the complete path and name of the firmware file on the PC (maximum 74 characters).
Example: 192.168.2.105/S670IP/FW_Datei.bin.
- ▶ Select **Set** to save the changes.
- ▶ Click the **Update Firmware** button to start the update.

This setting is automatically used for **this particular** firmware update. The URL in the **Data server** field is saved and used again for subsequent firmware updates. You will have to re-enter the IP address and file name to carry out another update with a firmware file on your local PC.

Please note

If an error occurs during a firmware update from a local PC, the most recent version of the firmware is automatically downloaded from the Internet.

Activating/deactivating the automatic version check

When the version check is activated, the phone checks on a daily basis whether the Gigaset configuration server has a new version of the phone firmware/provider profile (general provider data),

If a new version is available, a notification is sent to the handset and the Message key flashes. You can then perform an automatic update of the firmware (→ [Page 136](#)) or carry out a provider data update.

- ▶ Open the following Web page: **Settings** → **Miscellaneous**.
- ▶ Select **Yes** after **Automatic check for software/profile updates** to activate the automatic version check.
Select **No** if you do not want a version check to be carried out.
- ▶ Select **Set** to save the changes.

Please note

If the telephone is not connected to the Internet at the time when the check for new firmware is to be carried out (e.g. because the router is deactivated), the check is carried out as soon as the phone is reconnected to the Internet.

Copying the date/time from time server

The date and time are shown in the idle display of registered handsets. They are important, for example, for stating the correct time in the Calls list and for the "anniversary", "appointments" and "alarm clock" functions.

There are two methods for updating the time and date on your base station: manually with one of the registered handsets (→ [Page 16](#)) or automatically by synchronization with a time server on the Internet.

Activate/deactivate synchronization with a time server as follows:

- ▶ Open the following Web page: **Settings** → **Miscellaneous**.
- ▶ In the **Automatic adjustment of System Time with Time Server** field select **Yes** to activate synchronization between base station and a time server. If you select **No** the base station will not adopt time settings from a time server. In this case set the time and date manually using a handset.
- ▶ The **Last synchronisation with time server** field shows the last time the base station compared the time and date settings with a time server.
- ▶ In the **Time Server** field, enter the Internet address or name of the time server from which the base station should adopt its time and date settings (maximum 74 characters). The time server "europe.pool.ntp.org" is set as default on the base station. You can overwrite the setting.
- ▶ From the **Country** list, select the country in which your base station is being operated.

Setting the phone with the PC

- ▶ The **Time Zone** field shows the valid time zone for the **Country**. It shows the deviation between local time (not daylight saving time) and Greenwich Mean Time (GMT).
If a country is divided into various time zones, they will all appear in the list. Select the appropriate **Time Zone** for the base station from the list.
- ▶ The **Automatically adjust clock to summer-time changes** field is displayed if your time zone differentiates between daylight saving time and standard time.
Select **On** to change the time automatically to daylight saving time or standard time when daylight saving time begins and ends respectively.
Select **Off** if you do not want to change to daylight saving time.
Please note: If the date and time are updated by a time server that automatically switches between daylight saving time and standard time, you must always select **Off** here.
- ▶ Select the **Set** button to save the settings in your phone.

Once you have activated synchronization, the time and date are compared with a time server as soon as an Internet connection is established.

Synchronization will usually occur once a day (at night) if synchronization is activated. Any additional synchronization will take place only after each new system start of the base station (e.g. after a firmware update or a power cut). If you register a new handset on your base station it will assume the time and date of the base station without any additional synchronization with the time server.

Date and time settings are transferred to every handset after synchronization.

Please note

- ◆ The default time server "europe.pool.ntp.org" will remain stored in the base station even if you overwrite it. If you delete your time server from the **Time Server** field and synchronization is still activated, the base station will continue to synchronize with the default time server. However, it will no longer appear in the **Time Server** field.
 - ◆ If you have entered your own time server in the **Time Server** field and the base station is unable to synchronize for ten consecutive attempts, the base station will synchronize with the default time server.
 - ◆ If you have deactivated synchronization with a time server, and if the date and time are not set on any handset, then the base station will attempt to reference date and time settings from the CID information of an incoming call.
-

Querying the phone status

General information about your phone is displayed.

► In the menu list, select the **Status** tab.

The following information is displayed:

Area: IP Configuration

IP address The phone's current IP address within the local network. For information on how to assign the IP address, → [Page 151](#).

MAC address

The phone's device address.

Area: Software

Firmware version

Version of the firmware currently downloaded. You can download updates of the firmware to your phone (→ [Page 136](#)). Firmware updates are available on the Internet.

EEPROM version

Version of your phone's EEPROM storage chip (→ [Page 227](#)).

Getting help with your phone

Getting help with your phone

Questions and answers

If you have any questions about the use of your phone, you can contact us 24/7 at www.gigaset.com/customercare. The table below contains a list of common problems and possible solutions.

Please note

To ensure the quickest and most efficient response from Customer Service, please have the following information available:

- ◆ Version of firmware, EEPROM and your phone's MAC address
You can check this information with the Web configurator (→ [Page 189](#)).
For how to display the MAC address on your handset, → [Page 141](#).
 - ◆ VoIP status code (→ [Page 194](#))
For problems with VoIP connections, set VoIP status messages to be displayed on your handset (→ [Page 138](#), [Page 185](#)). These messages contain a status code that helps when the problem is analyzed.
-

The display is blank.

1. The handset is not switched on.
 - ▶ Press **and hold** the End Call key .
2. The battery is empty.
 - ▶ Charge the battery or replace it (→ [Page 14](#)).

The handset keys do not respond when pressed.

The keypad lock is activated.

- ▶ Press and **hold** the Pound key  (→ [Page 37](#)).

"Base X" flashes on the display.

1. The handset is out of range of the base station or the base station's range has decreased because Eco mode is active.
 - ▶ Move the handset closer to the base station.
 - ▶ If necessary deactivate Eco Mode (→ [Page 109](#)).
2. The handset has been deregistered.
 - ▶ Register the handset (→ [Page 113](#)).
3. The base station is not turned on.
 - ▶ Check the base station's power adapter (→ [Page 19](#)).
4. The base station firmware is currently being updated (→ [Page 136/Page 185](#)).
 - ▶ Please wait until the update is complete.

"Base Search" flashes in the display.

The handset is set to **Best Base** and no base station is turned on or within range.

- ▶ Move the handset closer to the base station.
- ▶ Check the base station mains adapter.

Handset does not ring.

1. The ringer is deactivated.
 - ▶ Activate the ringer (→ [Page 128](#)).
2. Call forwarding set to All Calls.
 - ▶ Deactivate call forwarding (VoIP: [Page 61/Page 170](#)).

You cannot hear a ringer/dialing tone from the fixed line network.

Base station's phone cord has been replaced.

- ▶ When purchasing a new cord, ensure that it has the correct jack pin connections (→ [Page 202](#)).

Error tone sounds after system PIN prompt.

You have entered the wrong system PIN.

- ▶ Re-enter system PIN.

Have you forgotten the system PIN?

- ▶ Reset the base station to set the system PIN back to 0000 (→ [Page 134](#)).

The other party cannot hear you.

You have pressed the  (INT) key or the Display key **Mute**. The handset is "muted".

- ▶ Activate the microphone again (→ [Page 53, Page 54](#)).

When making calls from the fixed line network, the caller's phone number is not displayed although CID (→ [Page 49](#)) is set.

Caller ID is not enabled.

- ▶ The **caller** should ask his network provider to enable Caller ID (CID).

You hear an error tone when keying an input

(a descending tone sequence).

Action has failed/invalid input.

- ▶ Repeat the operation.
Watch the display and refer to the user guide if necessary.

You cannot connect to the router and the phone is assigned a static IP address.

- ▶ Check on the router whether the IP address is already being used by another device in the LAN or belongs to the block of IP addresses that is reserved on the router for dynamic address assignment.
- ▶ If necessary, change the phone's IP address (→ [Page 139](#)).

You have made a call via VoIP but cannot hear the other caller.

Your phone is connected to a router with NAT/firewall.

- ▶ Your STUN server (→ [Page 160](#)) or outbound proxy (→ [Page 161](#)) settings are incomplete or incorrect. Check the settings.
- ▶ No outbound proxy is entered or the outbound proxy mode **Never** is activated (→ [Page 161](#)) and your phone is connected to a router with symmetric NAT or a blocking firewall.
- ▶ Port forwarding is activated on your router, but no permanent IP address has been assigned to your phone.

Getting help with your phone

You cannot make calls via VoIP. Server not accessible is displayed.

- ▶ First wait a few minutes. This is often a short-term event that corrects itself after a short time.

If the message continues to be displayed, proceed as follows:

- ▶ Check whether your phone's Ethernet cable is correctly connected to the router.
- ▶ Check your router's cable connection to the Internet.
- ▶ Check whether the phone is connected to the LAN. Send a ping command, e.g. from your PC, to the phone (ping □ <local IP address of the phone>). It may be that no IP address could be assigned to the phone or a permanently set IP address is already assigned to another LAN subscriber. Check the settings on the router, you may have to activate the DHCP server.

You cannot make calls via VoIP. Either Provider registration failed or Registration failed is shown.

- ▶ First wait a few minutes. This is often a short-term event that corrects itself after a short time.

The message may still be displayed for the following reasons:

1. The personal VoIP access data (Username, User Name and Authent. Password) you have entered may be incomplete or wrong.
 - ▶ Check your information. Particularly check your use of upper and lower case.
2. The general settings for your VoIP provider are incomplete or incorrect (incorrect server address).
 - ▶ Start the Web configurator and check the settings.

You cannot make calls via VoIP. IP configuration error: xxx (xxx = VoIP status code) appears in the display.

You are trying to make a call via a VoIP connection that is not properly configured.

- ▶ Start the Web configurator and check the settings. Possible status codes and their meanings are listed → [Page 194](#).

The phone does not dial an entered number. The display shows **Not possible**.

The number may be blocked (dialing plan).

- ▶ Open the **Dialling Plans** Web page of the Web configurator and delete or deactivate the block if necessary.

You cannot establish a connection to the phone with your PC's Web browser.

- ▶ When establishing a connection, check the phone's local IP address that has been entered. You can check the IP address on your handset.
- ▶ Check the LAN connections for the PC and phone.
- ▶ Check that your phone can be reached. Send a ping command, e.g. from your PC, to the phone (ping □ <local IP address of the phone>).
- ▶ You have tried to reach the phone via a secure http (https://...). Try again with http://...

You cannot be reached for calls from the Internet.

- ▶ There is no entry for your phone in your router's routing table. Check the settings for the NAT refresh time (→ [Page 161](#)).
- ▶ Your phone is not registered with the VoIP provider.
- ▶ You have entered the wrong user ID or an incorrect domain (→ [Page 158](#)).

Getting help with your phone

No firmware update or VoIP profile download is carried out.

1. If **Currently not possible** is displayed, the VoIP connections may be busy or a download/update is already being carried out.
 - ▶ Repeat the process at a later time.
2. If **File corrupted** is displayed, the firmware or profile file may be invalid.
 - ▶ Please only use firmware and downloads that are available on the preconfigured Gigaset configuration server (→ [Page 185](#)) or at www.gigaset.com/customer-care.
3. If **Server not accessible** is displayed, the download server may not be accessible.
 - ▶ The server is currently not accessible. Repeat the process at a later time.
 - ▶ You have changed the preconfigured server address (→ [Page 185](#)). Correct the address. If necessary, reset the base station.
4. If **Transmission error XXX** is displayed, an error has occurred during the transmission of the file. An HTTP error code is displayed for XXX.
 - ▶ Repeat the process. If the error occurs again, consult the Service department.
5. If **Check IP settings.** is displayed, your phone may not be connected to the Internet.
 - ▶ Check the cable connections between the phone and router and between the router and the Internet.
 - ▶ Check whether the phone is connected to the LAN, i.e. it can be reached at its IP address.

You cannot listen to or control a network mailbox.

VoIP:

Your VoIP provider does not support the type of DTMF signaling set up on your phone.

- ▶ Ask your VoIP provider which signaling it supports and change the settings on your phone (→ [Page 175](#)) if necessary.

Operating the base station within a PABX:

Your PABX is set for dial pulsing.

- ▶ Set your PABX to tone dialing.

No time is specified for a message in the Calls list.

Date and time have not been set.

- ▶ Set date/time (→ [Page 16](#)) or
- ▶ Activate base station synchronization with a time server on the Internet (→ [Page 187](#)).

The local answering machine announces "PIN is incorrect" during remote operation.

1. You have entered the wrong system PIN.
 - ▶ Enter the system PIN again.
2. The system PIN is still set to 0000.
 - ▶ Change the system PIN (→ [Page 132](#)).

Getting help with your phone

The local answering machine is not recording any messages/has switched over to answer only.

Its memory is full.

- ▶ Delete old messages.
- ▶ Play back new messages and delete.

The local answering machine will not record a call or interrupts the recording.

1. An error tone sounds and the display shows **Not possible**.

- ▶ You are making the call via a broadband VoIP connection. A recording is not possible in this case. The attempt by the base station to establish a non-broadband connection instead has failed (rearranging the codec).
If necessary, you or the other caller must change the setting for the codecs used (→ [Page 163](#)).

2. The display shows **Delete messages**

The answering machine's memory is full.

- ▶ Use a different handset to delete messages from the answering machine and restart two-way record.

Or:

- ▶ Finish the call, delete old messages from the answering machine and re-establish the connection.

Using VoIP status codes

If you have problems with your VoIP connections, activate the **Show Stat. on HS** function (→ [Page 138](#), [Page 185](#)). You will then receive a VoIP status code that will support you during the problem analysis. Provide the code to the Service department during the problem analysis.

In the following tables you will find the meaning of the most important status codes and messages.

Status code	Meaning
0x31	IP configuration error: IP domain not entered.
0x33	IP configuration error: SIP user name (Authentication Name) not entered. This is shown, for example, when dialing with a line suffix, if no connection is configured for the suffix on the base station.
0x34	IP configuration error: SIP password (Authentication password) not entered.
0x300	The called party can be reached under several phone numbers. If the VoIP provider supports this, a list of the phone numbers is transmitted as well as the status code. The caller can select to which number he wants to make the connection.
0x301	Permanently redirected. The called party can no longer be reached under this number. The new number is transferred to the phone together with the status code, and the phone then no longer accesses the old number but dials the new address immediately.

Getting help with your phone

Status code	Meaning
0x302	Temporarily redirected. The phone is informed that the called party cannot be reached under the dialed number. The call is redirected for a limited period. The phone is also notified of the length of the redirection.
0x305	The query is sent to a different "proxy server", e.g. to balance incoming queries. The phone will make the same query once again to another proxy server. This is not a redirection of the address per se.
0x380	Other service: The query or call could not be transferred. However the phone is notified what other options are available to connect the call.
0x400	Wrong call
0x401	Not authorized
0x403	The requested service is not supported by the VoIP provider.
0x404	Wrong phone number. No connection on this number. Example: In a local call you have not dialed the area code although your VoIP provider does not support local calls.
0x405	Method not permitted.
0x406	Not acceptable. The requested service cannot be provided.
0x407	Proxy authentication required.
0x408	The party cannot be reached (e.g. account has been deleted).
0x410	The requested service is not available from the VoIP provider.
0x413	Message is too long.
0x414	URI is too long.
0x415	Query format is not supported.
0x416	URI is faulty.
0x420	Incorrect ending
0x421	Incorrect ending
0x423	The requested service is not supported by the VoIP provider.
0x480	The dialed number is temporarily unavailable.
0x481	The recipient is not available.
0x482	Double service query
0x483	Too many "jumps": The query was rejected because the service server (proxy) has decided that this query has already passed through too many service servers. The maximum number is defined beforehand by the original sender of the query.

Getting help with your phone

Status code	Meaning
0x484	Wrong number: In most cases this response means that you have simply omitted one or more digits in the phone number.
0x485	The URI dialed is not unique and cannot be processed by the VoIP provider.
0x486	The called party is busy.
0x487	General faults: The call was canceled before a call was established. The status code confirms receipt of the interruption signal.
0x488	The server cannot process the query because the data entered in the media description is not compatible.
0x491	The server notifies that the query will be processed as soon as a previous query has been completed.
0x493	The server rejects the query because the phone cannot decrypt the message. The sender has used an encryption method that neither the server nor the receiver phone can decrypt.
0x500	The proxy or the receiving device has discovered a fault while executing the query. It is therefore impossible to execute the query. If this occurs, the caller or the phone displays the fault and repeats the query after a few seconds. The number of seconds after which the query can be repeated may be transmitted to the caller or phone by the receiving device.
0x501	The query cannot be processed by the recipient because the recipient does not have the functionality that the caller requires. If the recipient understands the query but does not process it because the sender does not have the necessary rights or the query is not permitted in the current context, status code 405 is transmitted instead of 501.
0x502	In this case, the receiving device that transmits this error code is a proxy or a gateway and has received an invalid response from its gateway via which this query is to be processed.
0x503	The query can currently not be processed by the receiving device or the proxy because the server is either overloaded or is being serviced. If it is possible for the query to be repeated in the foreseeable future, the server informs the caller or the phone to this effect.
0x504	Time limit exceeded at the gateway.
0x505	The server rejects the query because the indicated version number of the SIP protocol does not at least concur with the version that is used by server or the SIP device involved in this query.

Getting help with your phone

Status code	Meaning
0x515	The server rejects the query because the message exceeds the maximum permitted size.
0x600	The called party is busy.
0x603	The called party has rejected the call.
0x604	The called URI does not exist.
0x606	The communication settings are not acceptable.
0x701	The called party has hung up.
0x703	Connection canceled because of time-out.
0x704	Connection interrupted because of a SIP error.
0x705	Wrong dialing tone
0x706	No connection established
0x751	Busy tone: No codec match between the calling and called party.
0x810	General socket layer error: User is not authorized.
0x811	General socket layer error: Wrong socket number
0x812	General socket layer error: Socket is not connected.
0x813	General socket layer error: Memory error
0x814	General socket layer error: Socket not available – check IP settings/connection problem/VoIP setting incorrect.
0x815	General socket layer error: Illegal application on the socket interface.

Checking service information

You may need the service information of your phone (base station and handset) for Customer Service.

Base station service information

Prerequisite: You are conducting an external call. The connection has been established for at least 8 seconds.

Options → **Service Info**

Confirm selection with **OK**.

The following information/functions can be selected with :

- 1: Serial number of the base station (RFPI)
- 2: Serial number of your handset (IPUI)

Getting help with your phone

- 3: Informs the service employee of the base station settings (in hex format), e.g. the number of registered handsets. The last 4 digits indicate the number of operating hours (hexadecimal).
- 4: Variant (digits 1 to 2),
Version of the base station firmware (digits 3 to 5).
- 5: Gigaset.net number of your phone. With this number a service employee can call you over the Internet without you needing to be registered with a VoIP provider. This means that the employee can test online connections and VoIP telephony regardless of the VoIP provider.
- 6: Device number of the base station. Contains further information for the service employee.

Unlock System

Confirm selection with **OK**.

You can use a code to cancel any provider-specific device lock that may have been set.

Update Profile

Confirm selection with **OK**.

The current profiles of your VoIP providers (general provider data of all configured VoIP connections) are automatically loaded onto your phone. The general settings for all VoIP connections for which profiles are available on the Gigaset server are updated.

Service information of the handset

When the handset is in idle status:

Open the menu by pressing 

▶ Press the following keys one after the other:     

The information displayed on the handset includes:

- 1: Serial number (IPUI)
- 2: Number of operating hours
- 3: Variant (digits 1 to 2),
Version of the handset software (digits 3 to 5).

Protecting our environment

Our environmental mission statement

We, Gigaset Communications GmbH, bear social responsibility and are actively committed to a better world. Our ideas, technologies and actions serve people, society and the environment. The aim of our global activity is to secure sustainable life resources for humanity. We are committed to a responsibility for our products that comprises their entire life cycle. The environmental impact of products, including their manufacture, procurement, distribution, utilization, service and disposal, are already evaluated during product and process design. Further information on environmentally friendly products and processes is available on the Internet at www.gigaset.com.

Environmental management system



Gigaset Communications GmbH is certified pursuant to the international standards EN 14001 and ISO 9001.

ISO 14001 (Environment): certified since September 2007 by TÜV SÜD Management Service GmbH.

ISO 9001 (Quality): certified since 17/02/1994 by TÜV SÜD Management Service GmbH.

Ecological energy consumption

The use of ECO DECT (→ [Page 109](#)) saves energy and is an active contribution towards protecting the environment.

Disposal

Batteries should not be disposed of in general household waste. Observe the local waste disposal regulations, details of which can be obtained from your local authority or the dealer you purchased the product from.

All electrical and electronic equipment must be disposed of separately from general household waste using the sites designated by local authorities.



If a product displays this icon of a crossed-out trash can, the product is subject to European Directive 2002/96/EC.

The appropriate disposal and separate collection of used equipment serve to prevent potential harm to the environment and to health. They are a prerequisite for the re-use and recycling of used electrical and electronic equipment.

For further information on disposing of your used equipment, please contact your local authority, your refuse collection service or the dealer you purchased the product from.

Appendix

Appendix

Care

- ▶ Wipe down the base station and handset with a **damp** cloth (no solvents) or an antistatic cloth.

Never use a dry cloth as This can cause static.

Contact with liquid

If the handset should come into contact with liquid:

- ▶ **Switch the handset off and remove the batteries immediately.**
- ▶ Allow the liquid to drain from the handset.
- ▶ Pat all parts dry, then with the battery compartment open and the keypad facing down, place the handset in a dry, warm place **for at least 72 hours** (**not** in a microwave, oven, etc.).
- ▶ **Do not switch on the handset again until it is completely dry.**

When it has fully dried out, you will normally be able to use it again.

Specifications

Recommended batteries

Technology:	Nickel-metal-hydride (NiMH)
Size:	AAA (Micro, HR03)
Voltage:	1.2 V
Capacity:	600 – 1200 mAh

We recommend the following battery types, because these are the only ones that guarantee the specified operating times, full functionality and long service life:

- ◆ Sanyo NiMH 800
- ◆ GP 850 mAh
- ◆ Yuasa Technologies AAA 800

The device is supplied with two recommended rechargeable batteries.

Handset operating times/charging times

The operating time of your Gigaset depends on the capacity and age of the batteries and the way they are used. (All times are maximum possible times and apply when the display backlight is switched off).

	Capacity (mAh)			
	600	800	1000	1200
Standby time (hours)	130	175	220	265
Talktime (hours)	7	10	12	14
Operating time for 1.5 hrs of calls per day (hours)	70	90	115	135
Charging time, base station (hours)	6	9	11	13
Charging time, charging cradle (hours)	5	7	8	10

At the time of going to print, batteries up to 900 mAh were available and had been tested in the system. Due to the constant progression in battery development, the list of recommended batteries in the FAQ section of the Gigaset Customer Care pages is regularly updated:

www.gigaset.com/customer-care

Base station power consumption

The power consumption for the base station is approx. 1.3 watt.

General specifications

Interfaces	Fixed line network, Ethernet
No. of channels	60 duplex channels
Radio frequency range	1880–11900 MHz
Duplex method	Time multiplex, 10 ms frame length
Channel grid	1728 kHz
Bit rate	1152 kbit/s
Modulation	GFSK
Language code	32 kbit/s
Transmission power	10 mW, average power per channel
Range	up to 328 yards outdoors, up to 55 yards indoors
Base station power supply	230 V ~/50 Hz
Environmental conditions in operation	+41°F to +113°F; 20% to 75% relative humidity
Codecs	G.711, G.726, G.729AB with VAD/CNG, G.722
Quality of Service	TOS, DiffServ
Protocols	DECT, GAP, SIP, RTP, DHCP, NAT Traversal (STUN), HTTP

Appendix

Pin connections on the telephone jack

If you buy a replacement phone cord from a retailer, pay attention to the wiring of the phone jack.

Correct pin assignment on the phone jack

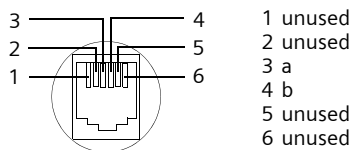

Writing and editing text

The following rules apply when writing text:

- ◆ Control the cursor with .
- ◆ Characters are inserted to the left of the cursor.
- ◆ Press the Asterisk key to display the table of special characters (→ "Entering special characters".)
- ◆ The first letter of the name of directory entries is automatically capitalized, followed by lower case letters.

Entering special characters

- ▶ Press the Asterisk key .

A table is opened containing all the special characters. The cursor is positioned on the character "." (period).

␣	_	!	?	@	,	'	"	▯
()	;	:	.	-	+	&	%
*	=	<	>	/	€	£	\$	¥
[]	§	↵	\	~	^	ˆ	ı
{	}	#						

- ▶ Navigate to the required character with the Control key , . Example: to select * press 4 x and 1 x .
- ▶ Press the Display key **Insert**. The character is inserted into the text. Pressing again closes the table without inserting a character.

Writing a text/name (without predictive text)

Press the relevant key several times to enter letters/characters.

Standard characters

	1x	2x	3x	4x	5x	6x	7x	8x	9x	10x
1 sp	¹⁾	²⁾	1							
2 abc	a	b	c	2	ä	á	à	â	ã	ç
3 def	d	e	f	3	ë	é	è	ê		
4 ghi	g	h	i	4	ï	í	ì	î		
5 jkl	j	k	l	5						
6 mno	m	n	o	6	ö	ñ	ó	ò	ô	õ
7 pqrs	p	q	r	s	7	ß				
8 tuv	t	u	v	8	ü	ú	ù	û		
9 wxyz	w	x	y	z	9	ÿ	ý	æ	ø	å
0 =	.	,	?	!	0					

- 1) Space
- 2) Line break

When you press and **hold** a key, the characters of the corresponding key are displayed in the **bottom display line** and marked one after another. When you release the key, the highlighted character is inserted into the input field.

Setting upper/lower case or digits

Press the Pound key **before** entering the character to switch from "Abc" mode to "123", from "123" to "abc" and from "abc" to "Abc" (upper case: 1st letter upper case, all others lower case).

The display shows whether upper case, lower case or digits is selected. The bottom right of the display (above the right Display key) shows "Abc", "abc" or "123".

Writing a text/name (with predictive text)

The predictive text function helps you when you are writing messenger messages.

Appendix

Each key between **0** and **9** is assigned several letters and characters (→ [Entering special characters](#), [Page 202](#)). These appear in a selection line immediately under the text panel (above the Display keys) as soon as you press a key. The letter you are most likely looking for is reverse highlighted and is at the beginning of the selection line. It is copied to the text panel.

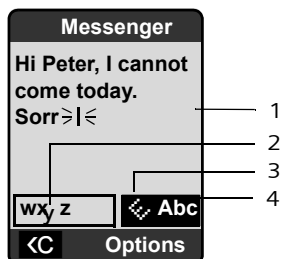

- 1 Message text
- 2 Selection line
- 3 Predictive text is activated
- 4 Upper/lower case or digits

If this letter is the one you want, confirm it by pressing the next key. If it does not match the one you want, press the Pound key **#->** **briefly** until the letter you are looking for is reverse highlighted in the display line and then transferred to the text field.

If you press and **hold** the Pound key **#->** you switch from "Abc" mode to "123" and from "123" to "abc" and from "abc" to "Abc".

Deactivating/activating predictive text

- ▶ You are writing a messenger message (→ [Page 88](#)).



Press the Display key.

Predictive Text

Select and press **OK** (**✓** = on).



Press the End Call key **briefly** to return to the text field. Enter the text.

Setting input language

- ▶ You are writing a messenger message (→ [Page 88](#)).



Press the Display key.

Select Language

Select and press **OK**.



Select input language and press **OK**.



Press the End Call key **briefly** twice to return to the input field.

The input language setting only applies to the current message.

Order of directory entries

Directory entries are generally sorted alphabetically by last name. Spaces and digits take first priority. If only the first name was entered in the directory, this is incorporated into the sort order instead of the last name.

The sort order is as follows:

- 1 Space
- 2 Digits (0–9)
- 3 Letters (alphabetical)
- 4 Other characters

To get round the alphabetical order of the entries, insert a space or a digit in front of the first letter of the last name. These entries will then move to the beginning of the directory. Names that you have prefixed with an asterisk will move to the end of the directory.

Industry Canada Certification

Industry Canada Certification

Operation is subject to the following two conditions (1) this device may not cause interference, and (2) this device must accept any interference, including interference that may cause undesired operation of the device.

NOTICE: The Industry Canada label identifies certified equipment. This certification means that the equipment meets certain telecommunications network, protective, operational and safety requirements as prescribed in the appropriate Terminal Equipment Technical Requirements document(s). The Department does not guarantee the equipment will operate to the user's satisfaction.

Before installing this equipment, users should ensure that it is permissible to be connected to the facilities of the local telecommunications company. The equipment must also be installed using an acceptable method of connection. The customer should be aware that compliance with the above conditions may not prevent degradation of service in some situations.

Repairs to certified equipment should be coordinated by a representative designated by the supplier. Any repairs or alterations made by the user to this equipment, or equipment malfunctions, may give the telecommunications company cause to request the user to disconnect the equipment.

Users should ensure for their own protection that the electrical ground connections of the power utility, telephone lines and internal metallic water pipe system, if present, are connected together.

This precaution may be particularly important in rural areas

NOTE: Users should not attempt to make such connections themselves, but should contact the appropriate electric inspection authority, or electrician, as appropriate.

This product meets the applicable Industry Canada technical specifications.

The Ringer Equivalence Number is an indication of the maximum number of devices allowed to be connected to a telephone interface. The termination of an interface may consist of any combination of devices subject only to the requirement that the sum of the RENs of all devices does not exceed five.

This Class B digital apparatus complies with Canadian ICES-003.

Cet appareil numérique de la classe B est conforme à la norme NMB-003 du Canada.

FCC / ACTA Information

Warning: Changes or modifications to this unit not expressly approved by Gigaset Communications USA LLC could void the FCC authority to operate the equipment. This includes the addition of any external antenna device.

This equipment complies with Part 68 of the FCC rules and the requirements adopted by the ACTA. On the bottom of the base station is a label that contains, among other information, a product identifier in the format US:AAAEQ##TXXXX. If requested, this number must be provided to the telephone company.

A plug and jack used to connect this equipment to the premises wiring and telephone network must comply with the applicable FCC Part 68 rules and requirements adopted by the ACTA. A compliant telephone cord and modular plug is provided with this product. It is designed to be connected to a compatible modular jack that is also compliant. See installation instructions for details.

The REN is used to determine the number of devices that may be connected to a telephone line. Excessive RENs on a telephone line may result in the devices not ringing in response to an incoming call. In most but not all areas, the sum of RENs should not exceed five (5.0). To be certain of the number of devices that may be connected to a line, as determined by the total RENs, contact the local telephone company. For products approved after July 23, 2001, the REN for this product is part of the product identifier that has the format US:AAAEQ##TXXXX. The digits represented by ## are the REN without a decimal point (e.g., 03 is a REN of 0.3). For earlier products, the REN is separately shown on the label.

A copy of the supplier's Declaration of Conformity (SDoC) is available at this Internet address: www.gigaset.com/docs.

If this equipment causes harm to the telephone network, the telephone company will notify you in advance, that temporary discontinuance of service may be required. But if advance notice isn't practical, the telephone company will notify the customer as soon as possible. Also, you will be advised of your right to file a complaint with the FCC if you believe it is necessary.

The telephone company may make changes in its facilities, equipment, operations or procedures that could affect the operation of the equipment. If this happens the telephone company will provide advance notice in order for you to make necessary modifications to maintain uninterrupted service. If you experience trouble with this telephone system, disconnect it from the network until the problem has been corrected or until you are sure that the equipment is not malfunctioning.

If trouble is experienced with this equipment, for repair or warranty information, please contact Support at 1-866-247-8758. If the equipment is causing harm to the telephone network, the telephone company may request that you disconnect the equipment until the problem is resolved. This equipment is of a type that is not intended to be repaired by the Customer (user).

This telephone system may not be used on coin service provided by the telephone company. Connection to party line service is subject to state tariffs. Contact the state public utility commission, public service commission or corporation commission for information. Privacy of communications may not be ensured when using this phone.

If your home has specially wired alarm equipment connected to the telephone line, ensure the installation of this equipment does not disable your alarm equipment. If you have questions about what will disable alarm equipment, consult your telephone company or a qualified installer.

This telephone system equipment has been tested and found to comply with the limits for Class B digital device, pursuant to Part 15 of the FCC Rules. Operation is subject to the following two conditions: (1) This device may not cause harmful interference, and (2) This device must accept any interference received, including interference that may cause undesired operation. These limits are designed to provide reasonable protection against harmful interference in a residential installation. Some cordless telephones operate at frequencies that may cause interference to nearby TV's and VCR's; to minimize or prevent

FCC / ACTA Information

such interference, the system base should not be placed near or on top of a TV or VCR; and, if interference is experienced, moving the base farther away from the TV or VCR will often reduce or eliminate the interference.

However, there is no guarantee that interference will not occur in a particular installation. If this telephone system does cause harmful interference to radio or television reception, which can be determined by turning the system off and on, the user is encouraged to try to correct the interference by one or more of the following measures:

1. Reorient or relocate the receiving antenna.
2. Increase the separation between the base station and receiver.
3. Connect the base station into an outlet on a circuit different from that to which the receiver is connected.
4. Consult the dealer or an experienced radio TV technician for help.

Notice for Direct Inward Dialing ("DID")

ALLOWING THIS EQUIPMENT TO BE OPERATED IN SUCH A MANNER AS TO NOT PROVIDE FOR PROPER ANSWER SUPERVISION IS A VIOLATION OF PART 68 OF THE FCC'S RULES.

Notice to Hearing Aid Wearers:

This phone system is compatible with inductively coupled hearing aids.

Power Outage:

In the event of a power outage, your cordless telephone will not operate. The cordless telephone requires electricity for operation. You should have a telephone that does not require electricity available for use during power outages.

Notice:

The installation of the base unit should allow at least 8 inches between the base and persons to be in compliance with FCC RF exposure guidelines.

For body worn operation, the portable part (handset) has been tested and meets FCC RF exposure guidelines. Use with an accessory that contains metal parts may not ensure compliance with FCC RF exposure guidelines.

Notice to telephone company service:

If you need service from your telephone company, please provide them with the information

- Facility interface Code (FIC)
- Service Order Code (SOC)
- Universal Service Order Code (USOC)

as indicated on the label on the bottom side of the base station.

Safety precautions

Before using your telephone equipment, basic safety instructions should always be followed to reduce the risk of fire, electric shock and injury to persons.

1. Read and understand all instructions.
2. Follow all warnings and instructions marked on the product.
3. Unplug this product from the wall telephone jack and power outlet before cleaning. Do not use liquid cleaners or aerosol cleaners. Use damp cloth for cleaning.
4. Do not use this product near water, for example, near a bathtub, wash bowl, kitchen sink, or laundry tub, in a wet basement or near a swimming pool.
5. Place this product securely on a stable surface. Serious damage and/or injury may result if the unit falls.
6. Slots or openings in the cabinet and the back and bottom are provided for ventilation, to protect it from overheating. These openings must not be blocked or covered. This product should never be placed near or over a radiator or heat register, or in a place where proper ventilation is not provided.
7. This product should be operated only from the type of power source indicated on the marking label. If you are not sure of the type of AC line power to your home, consult your dealer or local power company.
8. Do not place objects on the power cord. Install the unit where no one can step or trip on the cord.
9. Do not overload wall outlets and extension cords as this can result in the risk of fire or electric shock.
10. Never push objects of any kind into this product through cabinet slots as they may touch dangerous voltage points or short out parts that could result in the risk of fire or electric shock. Never spill liquid of any kind on this product.
11. To reduce the risk of electric shock or burns, do not disassemble this product. Take it to a qualified service center when service is required. Opening or removing covers may expose you to dangerous voltages, dangerous electrical current or other risks. Incorrect reassembly can cause electric shock when the appliance is subsequently used.
12. Unplug the product from the wall outlet and refer servicing to qualified service personnel under the following conditions:
 - a.) When the power cord is damaged or frayed.
 - b.) If liquid has been spilled into the product.
 - c.) If the product has been exposed to rain or water.
 - d.) If the product does not operate normally by following the operating instructions. Adjust only those controls that are covered by the operating instructions because improper adjustment of other controls may result in damage and may require extensive work by a qualified technician to restore the product to normal operation.
 - e.) If the product has been dropped or physically has been damaged.
 - f.) If the product exhibits a distinct change in performance.
13. Avoid using a telephone (other than a cordless type) during a thunderstorm. There may be a remote risk of electrical shock from lightning. Therefore we suggest a surge arrester.
14. Do not use the telephone to report a gas leak in the vicinity of the leak.
15. Emergency/911 numbers may not be dialed if the keypad is locked.
16. Minimum No. 26 AWG telecommunication line cord must be used with this phone.

FCC / ACTA Information

BATTERY SAFETY PRECAUTIONS

To reduce the risk of fire, injury or electric shock, and to properly dispose of batteries, please read and understand the following instructions.

CONTAINS NICKEL METAL HYDRIDE BATTERY. BATTERY MUST BE RECYCLED OR DISPOSED OF PROPERLY. DO NOT DISPOSE OF IN MUNICIPAL WASTE.

1. Only use the batteries specified for use with this product.
2. DO NOT USE NICKEL CADMIUM OR LITHIUM BATTERIES, or mix batteries of different sizes or from different manufacturers in this product. DO NOT USE NONRECHARGEABLE BATTERIES.
3. Do not dispose of the batteries in a fire; the cells may explode. Do not expose batteries to water. Check with local codes for special disposal instructions.
4. Do not open or mutilate the batteries. Released electrolyte is corrosive and may cause damage to the eyes or skin. The electrolyte may be toxic if swallowed.
5. Exercise care in handling the batteries in order not to short the batteries with conducting materials such as rings, bracelets, and keys. The batteries or conducting material may overheat and cause burns or fire.
6. Charge the batteries provided with, or identified for use with, this product only in accordance with the instructions and limitations specified in the user's manual. Do not attempt to charge the batteries with any means other than that specified in the users manual.
7. Periodically clean the charge contacts on both the charger and handset.

Service (Customer Care)

Customer Care Warranty for Cordless Products

To obtain Customer Care Warranty service,
product operation information, or for problem resolution, call:

Toll Free: 1-866-247-8758

7:00 a.m. – 7:00 p.m. EST Monday-Saturday excluding holidays (English)

7:00 a.m. - 12:00 p.m. (noon) EST Monday-Saturday excluding holidays (French)

End-user limited warranty

This product is covered by a one year limited warranty. Any repair replacement or warranty service, and all questions about this product should be directed to: 1-866-247-8758.

This limited, non-transferable warranty is provided to the original buyer/end-consumer ("you") for systems, handsets and accessories (collectively, "Product") provided by Gigaset Communications USA LLC or Gigaset Communications Canada Inc. (collectively "Gigaset NAM"). Gigaset NAM warrants to you that at the date of purchase, the Product is free of defects in workmanship and materials and the software included in the Product will perform in substantial compliance to its program specifications.

1. WARRANTY PERIOD

The Product warranty period is one (1) year from the original date of purchase by you. Proof of purchase (e.g., sales slip or invoice) must be provided with any Product returned during the warranty period. Batteries supplied with the Products are warranted to be free from defects at the time of purchase only.

2. EXCLUSIVE REMEDY

Gigaset NAM's entire liability and your exclusive remedy if the Product is defective in materials or workmanship during the warranty period and is returned shall be that the Product will be repaired or replaced as set forth in Section 4 below. Reconditioned replacement components, parts or materials may be used in the replacement or repair. Data in the memory of the Product may be lost during repair.

3. THIS LIMITED WARRANTY DOES NOT COVER AND IS VOID WITH RESPECT TO THE FOLLOWING:

- Cosmetic damage, physical damage to the surface of the Product, including, without limitation, breakage, cracks, dents, scratches or adhesive marks on the LCD screen or outside casing of the Product.
- Products which have been repaired, maintained or modified (including the antenna) by anyone other than Gigaset NAM or a Gigaset NAM-approved repair facility, or that have been improperly installed.
- Cost of installation, removal or reinstallation.
- Damage due to any telephone, electronic, hardware or software program, network, Internet or computer malfunctions, failures, or difficulties of any kind, including without limitation, server failure or incomplete, incorrect, garbled or delayed computer transmissions.
- Equipment and components not manufactured, supplied or authorized by Gigaset NAM.
- Modification of the Product's components, or operation of the Product in an unsuitable environment or in a manner for which it is not intended, including but not limited

Service (Customer Care)

to failures or defects caused by misuse, abuse, accidents, physical damage, abnormal operation, improper handling or storage, neglect, alterations, unauthorized installation, removal or repairs, failure to follow instructions, problems caused by the carrier's network coverage, exposure to fire, water or excessive moisture or dampness, floods, or extreme changes in climate or temperature, acts of God, riots, acts of terrorism, spills of food or liquids, viruses or other software flaws introduced into the Product or other acts which are not the fault of Gigaset NAM and which the Product is not specified to tolerate, including damage caused by mishandling or blown fuses.

- Products which have had warranty stickers, electronic serial number and/or serial number label removed, altered, rendered illegible or fraudulently applied to other equipment.
- Signal reception problems (unless caused by defect in material or workmanship in the Product).
- Products operated outside published maximum ratings.
- Performance of the Products when used in combination with other products or equipment not manufactured, supplied or authorized by Gigaset NAM.
- Consumables (such as batteries and fuses).
- Payments for labor or service to representatives or service centers not authorized to perform product maintenance by Gigaset NAM.
- Loss of data.
- Testing and examination discloses that the alleged defect or malfunction in the Product does not exist.

This warranty does not cover customer education, instruction, installation or removal, set up adjustments, problems related to service(s) provided by a carrier or other service provider, and/or signal reception problems. Gigaset NAM shall not be responsible for software, firmware, information, or memory data contained in, stored on, or integrated with any Products returned for repair, whether under warranty or not. This warranty is valid only in the country in which it is purchased (*i.e.*, the United States of America or Canada respectively, but not both).

USE WITH ACCESSORIES NOT SUPPLIED BY GIGASET NAM OR NOT OTHERWISE EXPRESSLY AUTHORIZED BY GIGASET NAM MAY VOID WARRANTY.

4. WARRANTY CLAIM PROCEDURE

All warranty claims must be made by notifying Gigaset NAM prior to the expiration of the warranty period. Gigaset NAM's obligation to provide warranty support shall not extend past the end of the warranty period, except that any product repaired or replaced during the warranty period shall continue to be warranted for the balance of such warranty period or thirty (30) days, whichever is greater.

Throughout the warranty period, Support will be available 7:00 a.m. – 7:00 p.m. EST Monday-Saturday (English) and 7:00 a.m. - 12:00 p.m. (noon) EST Monday-Saturday (French), excluding National holidays. Support service will be provided for you by accessing the toll free customer service number:

1-866-247-8758

5. LIMITATION OF WARRANTY

Gigaset NAM makes no warranty or representation that the software in the Products will meet your requirements or will work in combination with any hardware or applications software products provided by third parties, that the operation of the software will be uninterrupted or error free, or that all defects in the software products will be corrected.

6. LIMITATION ON REMEDIES; NO CONSEQUENTIAL OR OTHER DAMAGES

Your exclusive remedy for any breach of this limited warranty is as set forth above. Except for any refund elected by Gigaset NAM, **YOU ARE NOT ENTITLED TO ANY DAMAGES, INCLUDING BUT NOT LIMITED TO CONSEQUENTIAL DAMAGES**, if the Product does not meet the limited warranty, and, to the maximum extent allowed by applicable law, even if any remedy fails of its essential purpose. The terms below ("Exclusion of Incidental, Consequential and Certain Other Damages") are also incorporated into this limited warranty. Some states/jurisdictions/provinces do not allow the exclusion or limitation of incidental or consequential damages, so the above limitation or exclusion may not apply to you. This limited warranty gives you specific legal rights. You may have others which vary from state/jurisdiction/province to state/jurisdiction/province.

7. DISCLAIMER OF WARRANTIES

GIGASET NAM AND ITS SUPPLIERS PROVIDE THE PRODUCT AND SUPPORT SERVICES (IF ANY) AS IS AND WITH ALL FAULTS. THE LIMITED WARRANTY IS IN LIEU OF ANY OTHER EXPRESS WARRANTIES (IF ANY) CREATED BY ANY DOCUMENTATION OR PACKAGING EXCEPT FOR THE LIMITED WARRANTY, AND TO THE MAXIMUM EXTENT PERMITTED BY APPLICABLE LAW IS IN LIEU OF ANY IMPLIED OR STATUTORY WARRANTIES, INCLUDING, BUT NOT LIMITED TO, THE IMPLIED WARRANTIES OF MERCHANTABILITY AND FITNESS FOR A PARTICULAR PURPOSE, OF ACCURACY OR COMPLETENESS OR RESPONSES, OF RESULTS, OF WORKMANLIKE EFFORT, OF LACK OF VIRUSES AND OF LACK OF NEGLIGENCE, ALL WITH REGARD TO THE PRODUCT, AND THE PROVISION OF OR FAILURE TO PROVIDE SUPPORT SERVICES. ALSO, THERE IS NO WARRANTY OR CONDITION OF TITLE, QUIET ENJOYMENT, QUIET POSSESSION, OR CORRESPONDENCE TO DESCRIPTION OR NONINFRINGEMENT WITH REGARD TO THE PRODUCT. Some states/jurisdictions/provinces do not allow limitations on how long an implied warranty lasts or the exclusion or limitation of incidental or consequential damages, so the above exclusions or limitations may not apply to you. If an implied warranty or condition is created by your state/province and federal or state/provincial law prohibits disclaimer of it, you also have an implied warranty or condition, **BUT ONLY AS TO DEFECTS DISCOVERED DURING THE PERIOD OF THIS LIMITED WARRANTY (ONE YEAR)**. AS TO ANY DEFECTS DISCOVERED AFTER THE ONE YEAR PERIOD, THERE IS NO WARRANTY OR CONDITION OF ANY KIND. This limited warranty gives you specific legal rights, and you may also have other rights which vary from state to state/province to province. In no event shall Gigaset NAM's liability exceed the cost of repairing or replacing defective Products as provided herein, and any such liabilities will terminate upon expiration of the warranty period.

Any supplements or updates to the Product or the software in the Product, including without limitation, any (if any) software fixes or upgrades or bug fixes provided to you after the expiration of the one year limited warranty period are not covered by any warranty or condition, express, implied or statutory.

Service (Customer Care)

8. EXCLUSION OF INCIDENTAL, CONSEQUENTIAL AND CERTAIN OTHER DAMAGES

TO THE MAXIMUM EXTENT PERMITTED BY APPLICABLE LAW, IN NO EVENT SHALL GIGASET NAM, SELLER OR THEIR SUPPLIERS BE LIABLE FOR ANY SPECIAL, INCIDENTAL, INDIRECT, OR CONSEQUENTIAL DAMAGES WHATSOEVER (INCLUDING, BUT NOT LIMITED TO, DAMAGES FOR LOSS OF PROFITS OR CONFIDENTIAL OR OTHER INFORMATION, FOR BUSINESS INTERRUPTION, FOR PERSONAL INJURY, FOR LOSS OF PRIVACY, FOR FAILURE TO MEET ANY DUTY INCLUDING OF GOOD FAITH OR OF REASONABLE CARE, FOR NEGLIGENCE, AND FOR ANY OTHER PECUNIARY OR OTHER LOSS WHATSOEVER) ARISING OUT OF OR IN ANY WAY RELATED TO THE USE OF OR INABILITY TO USE THE PRODUCT, THE PROVISION OF OR FAILURE TO PROVIDE SUPPORT SERVICES, OR OTHERWISE UNDER OR IN CONNECTION WITH ANY PROVISION OF THIS LIMITED WARRANTY, EVEN IN THE EVENT OF THE FAULT, TORT (INCLUDING NEGLIGENCE), STRICT LIABILITY, BREACH OF CONTRACT OR BREACH OF WARRANTY OF GIGASET NAM OR SELLER OR ANY SUPPLIER, AND EVEN IF GIGASET NAM OR SELLER OR ANY SUPPLIER HAS BEEN ADVISED OF THE POSSIBILITY OF SUCH DAMAGES. REPAIR OR REPLACEMENT, AS PROVIDED UNDER THE WARRANTY, IS YOUR SOLE AND EXCLUSIVE REMEDY FOR BREACH OF THE LIMITED WARRANTY.

9. LIMITATION OF LIABILITY AND REMEDIES

NOTWITHSTANDING ANY DAMAGES THAT YOU MIGHT INCUR FOR ANY REASON WHATSOEVER (INCLUDING, WITHOUT LIMITATION, ALL DAMAGES REFERENCED ABOVE AND ALL DIRECT OR GENERAL DAMAGES), THE ENTIRE LIABILITY OF GIGASET NAM, SELLER AND ANY OF THEIR SUPPLIERS UNDER ANY PROVISION OF THIS LIMITED WARRANTY AND YOUR EXCLUSIVE REMEDY FOR ALL OF THE FOREGOING (EXCEPT FOR ANY REMEDY OF REPAIR OR REPLACEMENT ELECTED BY GIGASET NAM OR SELLER OR SUPPLIER WITH RESPECT TO ANY BREACH OF THE LIMITED WARRANTY) SHALL BE LIMITED TO THE GREATER OF THE AMOUNT ACTUALLY PAID BY YOU FOR THE PRODUCT OR FIVE DOLLARS (\$5.00 USD/CAN). THE FOREGOING LIMITATIONS, EXCLUSIONS AND DISCLAIMERS SHALL APPLY TO THE MAXIMUM EXTENT PERMITTED BY APPLICABLE LAW, EVEN IF ANY REMEDY FAILS ITS ESSENTIAL PURPOSE.

10. GOVERNING LAW

If this Product was purchased in the United States of America this limited warranty will be governed by the laws of Texas, and exclude the United Nations Convention on Contracts for the International Sale of Goods. If this Product was purchased in Canada this limited warranty will be governed by the laws of the Province of Ontario and the federal laws of Canada applicable therein, and exclude the United Nations Convention on Contracts for the International Sale of Goods.

If you want to learn more about Gigaset Service or for Support on your Gigaset phone, visit our web site at <http://www.gigaset.com> or please call **1-866-247-8758**.

Issued by
Gigaset Communications GmbH
Schlavenhorst 66, D-46395 Bocholt
Gigaset Communications GmbH is a licensee of the Siemens trademark.

© Gigaset Communications GmbH 2009

All rights reserved.

Subject to availability. Rights of modifications reserved.

Product attributes subject to change.

We reserve the right, to make changes without notice in equipment design and/or components.

Part Number: none, © Copyright 2009.

Gigaset S675 IP – free software

Your Gigaset S675 IP's firmware includes free software that is licensed under the GNU Lesser General Public License. This free software was developed by a third party and is protected by copyright. You will find the license text in its original English version on the pages that follow.

The software is provided free of charge. You are authorized to use this free software in accordance with the above-mentioned license conditions. In the event of contradictions between these license conditions and the Gigaset Communications GmbH license conditions that apply for the software, the aforementioned license conditions shall take precedence for the free software.

The GNU Lesser General Public License (LGPL) is supplied with this product. You can also download the license conditions from the Internet:

- ◆ The **LGPL** is available on the Internet at:
<http://www.gnu.org/copyleft/lesser.html>
- ◆ The **source text, including copyright notices for free software**, is currently available on the Internet at:
<http://www.gigaset.com/developer>

For more information and Internet links to the source text of the free software, see the Online Support pages on the Internet at:

www.gigaset.com/customercare

If it is not already supplied with the product, you can request the source text, including copyright notices, from Gigaset Communications GmbH. There is a charge to cover the cost of copying and postage. Please submit this request by e-mail or fax to the following address or fax number within 3 years of purchasing this product. Please state the exact device type plus the version number of the installed device software.

Small Parts Dispatch Bocholt

E-mail: kleinteileversand.com@gigaset.com

Fax: 0049 2871 / 91 30 29

Use of the free software contained in this product extending beyond the program sequence intended by Gigaset Communications GmbH is at the user's own risk – i.e. there shall be no claims for liability for defects against Gigaset Communications GmbH. The GNU Lesser General Public License contains references to the liability for defects of authors or other proprietors of the free software.

You shall have no right to assert a claim against Gigaset Communications GmbH based on liability for defects if a defect in the product is or could be due to changes you have made to the programs or their configuration. Furthermore, you shall have no right to assert a claim against Gigaset Communications GmbH based on liability for defects if the free software violates the copyright of third parties.

Gigaset Communications GmbH shall not provide technical support for the software, including the free software included within it, if it has been changed.

Gigaset S675 IP – free software**GNU LESSER GENERAL PUBLIC LICENSE**

Version 2.1, February 1999

Copyright (C) 1991, 1999 Free Software Foundation, Inc., 59 Temple Place, Suite 330, Boston, MA 02111-1307 USA

Everyone is permitted to copy and distribute verbatim copies of this license document, but changing it is not allowed.

[This is the first released version of the Lesser GPL. It also counts as the successor of the GNU Library Public License, version 2, hence the version number 2.1.]

Preamble

The licenses for most software are designed to take away your freedom to share and change it. By contrast, the GNU General Public Licenses are intended to guarantee your freedom to share and change free software--to make sure the software is free for all its users.

This license, the Lesser General Public License, applies to some specially designated software packages—typically libraries—of the Free Software Foundation and other authors who decide to use it. You can use it too, but we suggest you first think carefully about whether this license or the ordinary General Public License is the better strategy to use in any particular case, based on the explanations below.

When we speak of free software, we are referring to freedom of use, not price. Our General Public Licenses are designed to make sure that you have the freedom to distribute copies of free software (and charge for this service if you wish); that you receive source code or can get it if you want it; that you can change the software and use pieces of it in new free programs; and that you are informed that you can do these things.

To protect your rights, we need to make restrictions that forbid distributors to deny you these rights or to ask you to surrender these rights. These restrictions translate to certain responsibilities for you if you distribute copies of the library or if you modify it.

For example, if you distribute copies of the library, whether gratis or for a fee, you must give the recipients all the rights that we gave you. You must make sure that they, too, receive or can get the source code. If you link other code with the library, you must provide complete object files to the recipients, so that they can relink them with the library after making changes to the library and recompiling it. And you must show them these terms so they know their rights.

We protect your rights with a two-step method: (1) we copyright the library, and (2) we offer you this license, which gives you legal permission to copy, distribute and/or modify the library.

To protect each distributor, we want to make it very clear that there is no warranty for the free library. Also, if the library is modified by someone else and passed on, the recipients should know that what they have is not the original version, so that the original author's reputation will not be affected by problems that might be introduced by others.

Finally, software patents pose a constant threat to the existence of any free program. We wish to make sure that a company cannot effectively restrict the users of a free program by obtaining a restrictive license from a patent holder. Therefore, we insist that any patent license obtained for a version of the library must be consistent with the full freedom of use specified in this license.

Most GNU software, including some libraries, is covered by the ordinary GNU General Public License. This license, the GNU Lesser General Public License, applies to certain designated libraries, and is quite different from the ordinary General Public License. We use this license for certain libraries in order to permit linking those libraries into non-free programs.

When a program is linked with a library, whether statically or using a shared library, the combination of the two is legally speaking a combined work, a derivative of the original library. The ordinary General Public License therefore permits such linking only if the entire combination fits its criteria of freedom. The Lesser General Public License permits more lax criteria for linking other code with the library.

We call this license the "Lesser" General Public License because it does less to protect the user's freedom than the ordinary General Public License. It also provides other free software developers less of an advantage over competing non-free programs. These disadvantages are the reason we use the ordinary General Public License for many libraries. However, the Lesser license provides advantages in certain special circumstances.

For example, on rare occasions, there may be a special need to encourage the widest possible use of a certain library, so that it becomes a de-facto standard. To achieve this, non-free programs must be allowed to use the library. A more frequent case is that a free library does the same job as widely used non-free libraries. In this case, there is little to gain by limiting the free library to free software only, so we use the Lesser General Public License.

In other cases, permission to use a particular library in non-free programs enables a greater number of people to use a large body of free software. For example, permission to use the GNU C Library in non-free programs enables many more people to use the whole GNU operating system, as well as its variant, the GNU/Linux operating system.

Although the Lesser General Public License is Less protective of the users' freedom, it does ensure that the user of a program that is linked with the Library has the freedom and the wherewithal to run that program using a modified version of the Library.

The precise terms and conditions for copying, distribution and modification follow. Pay close attention to the difference between a "work based on the library" and a "work that uses the library". The former contains code derived from the library, whereas the latter must be combined with the library in order to run.

GNU LESSER GENERAL PUBLIC LICENSE

TERMS AND CONDITIONS FOR COPYING, DISTRIBUTION AND MODIFICATION

0. This License Agreement applies to any software library or other program which contains a notice placed by the copyright holder or other authorized party saying it may be distributed under the terms of this Lesser General Public License (also called "this License"). Each licensee is addressed as "you".

A "library" means a collection of software functions and/or data prepared so as to be conveniently linked with application programs (which use some of those functions and data) to form executables.

The "Library", below, refers to any such software library or work which has been distributed under these terms. A "work based on the Library" means either the Library or any derivative work under copyright law: that is to say, a work containing the Library or a portion of it, either verbatim or with modifications and/or translated straightforwardly into another language. (Hereinafter, translation is included without limitation in the term "modification".)

"Source code" for a work means the preferred form of the work for making modifications to it. For a library, complete source code means all the source code for all modules it contains, plus any associated interface definition files, plus the scripts used to control compilation and installation of the library.

Activities other than copying, distribution and modification are not covered by this License; they are outside its scope. The act of running a program using the Library is not restricted, and output from such a program is covered only if its contents constitute a work based on the Library (independent of the use of the Library in a tool for writing it). Whether that is true depends on what the Library does and what the program that uses the Library does.

1. You may copy and distribute verbatim copies of the Library's complete source code as you receive it, in any medium, provided that you conspicuously and appropriately publish on each copy an appropriate copyright notice and disclaimer of warranty; keep intact all the notices that refer to this License and to the absence of any warranty; and distribute a copy of this License along with the Library.

You may charge a fee for the physical act of transferring a copy, and you may at your option offer warranty protection in exchange for a fee.

Gigaset S675 IP – free software

2. You may modify your copy or copies of the Library or any portion of it, thus forming a work based on the Library, and copy and distribute such modifications or work under the terms of Section 1 above, provided that you also meet all of these conditions:

- a) The modified work must itself be a software library.
- b) You must cause the files modified to carry prominent notices stating that you changed the files and the date of any change.
- c) You must cause the whole of the work to be licensed at no charge to all third parties under the terms of this License.
- d) If a facility in the modified Library refers to a function or a table of data to be supplied by an application program that uses the facility, other than as an argument passed when the facility is invoked, then you must make a good faith effort to ensure that, in the event an application does not supply such function or table, the facility still operates, and performs whatever part of its purpose remains meaningful.

(For example, a function in a library to compute square roots has a purpose that is entirely well-defined independent of the application. Therefore, Subsection 2d requires that any application-supplied function or table used by this function must be optional: if the application does not supply it, the square root function must still compute square roots.)

These requirements apply to the modified work as a whole. If identifiable sections of that work are not derived from the Library, and can be reasonably considered independent and separate works in themselves, then this License, and its terms, do not apply to those sections when you distribute them as separate works. But when you distribute the same sections as part of a whole which is a work based on the Library, the distribution of the whole must be on the terms of this License, whose permissions for other licensees extend to the entire whole, and thus to each and every part regardless of who wrote it. Thus, it is not the intent of this section to claim rights or contest your rights to work written entirely by you; rather, the intent is to exercise the right to control the distribution of derivative or collective works based on the Library.

In addition, mere aggregation of another work not based on the Library with the Library (or with a work based on the Library) on a volume of a storage or distribution medium does not bring the other work under the scope of this License.

3. You may opt to apply the terms of the ordinary GNU General Public License instead of this License to a given copy of the Library. To do this, you must alter all the notices that refer to this License, so that they refer to the ordinary GNU General Public License, version 2, instead of to this License. (If a newer version than version 2 of the ordinary GNU General Public License has appeared, then you can specify that version instead if you wish.) Do not make any other change in these notices.

Once this change is made in a given copy, it is irreversible for that copy, so the ordinary GNU General Public License applies to all subsequent copies and derivative works made from that copy.

This option is useful when you wish to copy part of the code of the Library into a program that is not a library.

4. You may copy and distribute the Library (or a portion or derivative of it, under Section 2) in object code or executable form under the terms of Sections 1 and 2 above provided that you accompany it with the complete corresponding machine-readable source code, which must be distributed under the terms of Sections 1 and 2 above on a medium customarily used for software interchange.

If distribution of object code is made by offering access to copy from a designated place, then offering equivalent access to copy the source code from the same place satisfies the requirement to distribute the source code, even though third parties are not compelled to copy the source along with the object code.

5. A program that contains no derivative of any portion of the Library, but is designed to work with the Library by being compiled or linked with it, is called a "work that uses the Library". Such a work, in isolation, is not a derivative work of the Library, and therefore falls outside the scope of this License.

However, linking a "work that uses the Library" with the Library creates an executable that is a derivative of the Library (because it contains portions of the Library), rather than a "work that uses the library". The executable is therefore covered by this License.

Section 6 states terms for distribution of such executables.

When a "work that uses the Library" uses material from a header file that is part of the Library, the object code for the work may be a derivative work of the Library even though the source code is not.

Whether this is true is especially significant if the work can be linked without the Library, or if the work is itself a library. The threshold for this to be true is not precisely defined by law.

If such an object file uses only numerical parameters, data structure layouts and accessors, and small macros and small inline functions (ten lines or less in length), then the use of the object file is unrestricted, regardless of whether it is legally a derivative work. (Executables containing this object code plus portions of the Library will still fall under Section 6.)

Otherwise, if the work is a derivative of the Library, you may distribute the object code for the work under the terms of Section 6.

Any executables containing that work also fall under Section 6, whether or not they are linked directly with the Library itself.

6. As an exception to the Sections above, you may also combine or link a "work that uses the Library" with the Library to produce a work containing portions of the Library, and distribute that work under terms of your choice, provided that the terms permit modification of the work for the customer's own use and reverse engineering for debugging such modifications.

You must give prominent notice with each copy of the work that the Library is used in it and that the Library and its use are covered by this License. You must supply a copy of this License. If the work during execution displays copyright notices, you must include the copyright notice for the Library among them, as well as a reference directing the user to the copy of this License. Also, you must do one of these things:

- a) Accompany the work with the complete corresponding machine-readable source code for the Library including whatever changes were used in the work (which must be distributed under Sections 1 and 2 above); and, if the work is an executable linked with the Library, with the complete machine-readable "work that uses the Library", as object code and/or source code, so that the user can modify the Library and then relink to produce a modified executable containing the modified Library. (It is understood that the user who changes the contents of definitions files in the Library will not necessarily be able to recompile the application to use the modified definitions.)
- b) Use a suitable shared library mechanism for linking with the Library. A suitable mechanism is one that (1) uses at run time a copy of the library already present on the user's computer system, rather than copying library functions into the executable, and (2) will operate properly with a modified version of the library, if the user installs one, as long as the modified version is interface-compatible with the version that the work was made with.
- c) Accompany the work with a written offer, valid for at least three years, to give the same user the materials specified in Subsection 6a, above, for a charge no more than the cost of performing this distribution.
- d) If distribution of the work is made by offering access to copy from a designated place, offer equivalent access to copy the above specified materials from the same place.
- e) Verify that the user has already received a copy of these materials or that you have already sent this user a copy.

For an executable, the required form of the "work that uses the Library" must include any data and utility programs needed for reproducing the executable from it. However, as a special exception, the materials to be distributed need not include anything that is normally distributed (in either source or binary form) with the major components (compiler, kernel, and so on) of the operating system on which the executable runs, unless that component itself accompanies the executable.

Gigaset S675 IP – free software

It may happen that this requirement contradicts the license restrictions of other proprietary libraries that do not normally accompany the operating system. Such a contradiction means you cannot use both them and the Library together in an executable that you distribute.

7. You may place library facilities that are a work based on the Library side-by-side in a single library together with other library facilities not covered by this License, and distribute such a combined library, provided that the separate distribution of the work based on the Library and of the other library facilities is otherwise permitted, and provided that you do these two things:

a) Accompany the combined library with a copy of the same work based on the Library, uncombined with any other library facilities. This must be distributed under the terms of the Sections above.

b) Give prominent notice with the combined library of the fact that part of it is a work based on the Library, and explaining where to find the accompanying uncombined form of the same work.

8. You may not copy, modify, sublicense, link with, or distribute the Library except as expressly provided under this License. Any attempt otherwise to copy, modify, sublicense, link with, or distribute the Library is void, and will automatically terminate your rights under this License. However, parties who have received copies, or rights, from you under this License will not have their licenses terminated so long as such parties remain in full compliance.

9. You are not required to accept this License, since you have not signed it. However, nothing else grants you permission to modify or distribute the Library or its derivative works. These actions are prohibited by law if you do not accept this License. Therefore, by modifying or distributing the Library (or any work based on the Library), you indicate your acceptance of this License to do so, and all its terms and conditions for copying, distributing or modifying the Library or works based on it.

10. Each time you redistribute the Library (or any work based on the Library), the recipient automatically receives a license from the original licensor to copy, distribute, link with or modify the Library subject to these terms and conditions. You may not impose any further restrictions on the recipients' exercise of the rights granted herein.

You are not responsible for enforcing compliance by third parties with this License.

11. If, as a consequence of a court judgment or allegation of patent infringement or for any other reason (not limited to patent issues), conditions are imposed on you (whether by court order, agreement or otherwise) that contradict the conditions of this License, they do not excuse you from the conditions of this License. If you cannot distribute so as to satisfy simultaneously your obligations under this License and any other pertinent obligations, then as a consequence you may not distribute the Library at all. For example, if a patent license would not permit royalty-free redistribution of the Library by all those who receive copies directly or indirectly through you, then the only way you could satisfy both it and this License would be to refrain entirely from distribution of the Library.

If any portion of this section is held invalid or unenforceable under any particular circumstance, the balance of the section is intended to apply, and the section as a whole is intended to apply in other circumstances.

It is not the purpose of this section to induce you to infringe any patents or other property right claims or to contest validity of any such claims; this section has the sole purpose of protecting the integrity of the free software distribution system which is implemented by public license practices. Many people have made generous contributions to the wide range of software distributed through that system in reliance on consistent application of that system; it is up to the author/donor to decide if he or she is willing to distribute software through any other system and a licensee cannot impose that choice.

This section is intended to make thoroughly clear what is believed to be a consequence of the rest of this License.

12. If the distribution and/or use of the Library is restricted in certain countries either by patents or by copyrighted interfaces, the original copyright holder who places the Library under this License may add an explicit geographical distribution limitation excluding those countries, so that distribution is permitted only in or among countries not thus

Gigaset S675 IP – free software

excluded. In such case, this License incorporates the limitation as if written in the body of this License.

13. The Free Software Foundation may publish revised and/or new versions of the Lesser General Public License from time to time. Such new versions will be similar in spirit to the present version, but may differ in detail to address new problems or concerns.

Each version is given a distinguishing version number. If the Library specifies a version number of this License which applies to it and "any later version", you have the option of following the terms and conditions either of that version or of any later version published by the Free Software Foundation. If the Library does not specify a license version number, you may choose any version ever published by the Free Software Foundation.

14. If you wish to incorporate parts of the Library into other free programs whose distribution conditions are incompatible with these, write to the author to ask for permission. For software which is copyrighted by the Free Software Foundation, write to the Free Software Foundation; we sometimes make exceptions for this. Our decision will be guided by the two goals of preserving the free status of all derivatives of our free software and of promoting the sharing and reuse of software generally.

NO WARRANTY

15. BECAUSE THE LIBRARY IS LICENSED FREE OF CHARGE, THERE IS NO WARRANTY FOR THE LIBRARY, TO THE EXTENT PERMITTED BY APPLICABLE LAW.

EXCEPT WHEN OTHERWISE STATED IN WRITING THE COPYRIGHT HOLDERS AND/OR OTHER PARTIES PROVIDE THE LIBRARY "AS IS" WITHOUT WARRANTY OF ANY KIND, EITHER EXPRESSED OR IMPLIED, INCLUDING, BUT NOT LIMITED TO, THE IMPLIED WARRANTIES OF MERCHANTABILITY AND FITNESS FOR A PARTICULAR PURPOSE. THE ENTIRE RISK AS TO THE QUALITY AND PERFORMANCE OF THE LIBRARY IS WITH YOU. SHOULD THE LIBRARY PROVE DEFECTIVE, YOU ASSUME THE COST OF ALL NECESSARY SERVICING, REPAIR OR CORRECTION.

16. IN NO EVENT UNLESS REQUIRED BY APPLICABLE LAW OR AGREED TO IN WRITING WILL ANY COPYRIGHT HOLDER, OR ANY OTHER PARTY WHO MAY MODIFY AND/OR REDISTRIBUTE THE LIBRARY AS PERMITTED ABOVE, BE LIABLE TO YOU FOR DAMAGES, INCLUDING ANY GENERAL, SPECIAL, INCIDENTAL OR CONSEQUENTIAL DAMAGES ARISING OUT OF THE USE OR INABILITY TO USE THE LIBRARY (INCLUDING BUT NOT LIMITED TO LOSS OF DATA OR DATA BEING RENDERED INACCURATE OR LOSSES SUSTAINED BY YOU OR THIRD PARTIES OR A FAILURE OF THE LIBRARY TO OPERATE WITH ANY OTHER SOFTWARE), EVEN IF SUCH HOLDER OR OTHER PARTY HAS BEEN ADVISED OF THE POSSIBILITY OF SUCH DAMAGES.

END OF TERMS AND CONDITIONS

Gigaset S675 IP – free software

How to Apply These Terms to Your New Libraries

If you develop a new library, and you want it to be of the greatest possible use to the public, we recommend making it free software that everyone can redistribute and change. You can do so by permitting redistribution under these terms (or, alternately, under the terms of the ordinary General Public License).

To apply these terms, attach the following notices to the library. It is safest to attach them to the start of each source file to most effectively convey the exclusion of warranty; and each file should have at least the "copyright" line and a pointer to where the full notice is found.

<one line to give the library's name and a brief idea of what it does.>

Copyright (C) <year> <name of author>

This library is free software; you can redistribute it and/or modify it under the terms of the GNU Lesser General Public License as published by the Free Software Foundation; either version 2.1 of the License, or (at your option) any later version.

This library is distributed in the hope that it will be useful, but WITHOUT ANY WARRANTY; without even the implied warranty of MERCHANTABILITY or FITNESS FOR A PARTICULAR PURPOSE. See the GNU Lesser General Public License for more details.

You should have received a copy of the GNU Lesser General Public License along with this library; if not, write to the Free Software Foundation, Inc., 59 Temple Place, Suite 330, Boston, MA 02111-1307 USA

Also add information on how to contact you by electronic and paper mail.

You should also get your employer (if you work as a programmer) or your school, if any, to sign a "copyright disclaimer" for the library, if necessary. Here is a sample; alter the names:

Yoyodyne, Inc., hereby disclaims all copyright interest in the library 'Frob' (a library for tweaking knobs) written by James Random Hacker. <signature of Ty Coon>, 1 April 1990
Ty Coon, President of Vice

Accessories

Gigaset handsets

Upgrade your Gigaset to a cordless PABX:

Gigaset S67H handset

- ◆ HDSP ready
- ◆ Illuminated graphical color display (65k colors)
- ◆ Illuminated keypad
- ◆ Speaker
- ◆ Polyphonic ringer melodies
- ◆ Directory for around 250 entries
- ◆ Picture Caller ID
- ◆ Headset socket
- ◆ Room monitor

www.gigaset.com/gigaset67h

www.gigaset.com/gigaset68h



Gigaset A58H handset

- ◆ Illuminated graphic display
- ◆ Illuminated keypad
- ◆ Speaker
- ◆ Polyphonic ringer melodies
- ◆ Directory for around 150 entries

www.gigaset.com/gigaset68h



All accessories are available from your phone retailer.



Use only original accessories. This will avoid possible health risks and damage to property, and also ensure that all the relevant regulations are complied with.

Glossary

Glossary

A

ADSL Asymmetric Digital Subscriber Line
Special form of **DSL**.

ALG Application Layer Gateway
NAT control mechanism of a router.
Many routers with integrated NAT use ALG. ALG lets the data packets in a VoIP connection pass and adds the public IP address of the secure private network. The router's ALG should be deactivated if the VoIP provider offers a STUN server or an outbound proxy.
See also: **Firewall**, **NAT**, **Outbound proxy**, **STUN**.

Authentication

Restriction of access to a network/service by use of an ID and password to log in.

Automatic ringback

See **Ringback when the number is busy**.

B

Block dialing

Enter the complete phone number, and correct it if necessary. Then pick up the handset or press the Speaker key to dial the phone number.

Broadband Internet access

See **DSL**.

Buddy Subscriber with whom you exchange brief messages on the Internet in real time (chatting).

See also: **Instant messaging**.

C

Call forwarding

CF

Automatic forwarding (CF) of a call to a different telephone number. There are three kinds of call forwarding:

- CFU, Call Forwarding Unconditional
- CFB, Call Forwarding Busy
- CFNR, Call Forwarding No Reply

Call diversion

See **Call forwarding**.

Call swap Call swap allows you to switch between two callers or between a conference call and an individual caller without allowing the waiting caller to listen to the call.

Call waiting = CW.

VoIP provider feature. A beep during a call indicates that another caller is waiting. You can accept or reject the second call. You can activate/deactivate the feature.

CF Call forwarding

See **Call forwarding**.

Chatting Form of communication on the Internet. During a chat, brief messages are exchanged between the communicating parties in real time. Chatting in this sense is understood to be a written form of communication.

Client Application that requests a service from a server.

Codec Coder/decoder

Codec is a procedure that digitizes and compresses analog voice before it is sent via the Internet, and decodes – i.e. translates into analog voice – digital data when voice packets are received. There are different codecs, with differing degrees of compression, for instance.

Both parties involved in the telephone connection (caller/sender and recipient) must use the same codec. This is negotiated between the sender and the recipient when establishing a connection.

The choice of codec is a compromise between voice quality, transmission speed and the necessary bandwidth. A high level of compression, for example, means that the bandwidth required for each voice connection is low. However, it also means that the time needed to compress/decompress the data is greater, which increases execution time for data in the network and thus impairs voice quality. The time required increases the delay between the sender speaking and the recipient hearing what has been said.

COLP / COLR

Connected Line Identification Presentation/Restriction

Service characteristic of a VoIP connection for outgoing calls.

COLP displays the phone number accepting the call on the calling party's display unit.

The number of the party accepting the call is different to the dialed number, e.g. if the call is forwarded or transferred.

The called party can use COLR (Connected Line Identification Restriction) to prevent the number from appearing on the calling party's display.

Consultation call

You are on a call. With a consultation call, you interrupt the conversation briefly to establish a second connection to another participant. If you terminate the connection to this participant immediately, then this was a consultation call. If you switch between the first and second participant, it is called **Call swap**.

Glossary

CW Call Waiting
See [Call waiting](#).

D

DHCP Dynamic Host Configuration Protocol
Internet protocol which regulates the automatic assignment of [IP addresses](#) to [Network subscribers](#). The protocol is made available in the network by a server. A DHCP server can, for example, be a router.

The phone contains a DHCP client. A router that contains a DHCP server can assign the IP addresses for the phone automatically from a defined address block. The dynamic assignment means that several [Network subscribers](#) can share one IP address, although they can only use it alternately and not simultaneously.

With some routers you can specify that the IP address for the phone is never changed.

Displayed name

VoIP provider feature. You can specify any name that is to be shown to the other party during a call instead of your phone number.

DMZ (Demilitarized Zone)

DMZ describes a part of a network that is outside the firewall.

A DMZ is set up, as it were, between a network you want to protect (e.g. a LAN) and a non-secure network (e.g. the Internet). A DMZ permits unrestricted access from the Internet to only one or a few network components, while the other network components remain secure behind the firewall.

DNS Domain Name System

Hierarchical system that enables assignment of [IP addresses](#) to [Domain names](#) that are easier to memorize. This assignment must be managed in each (W)LAN from a local DNS server. The local DNS server determines the IP address, if necessary by enquiring about superordinate DNS servers and other local DNS servers on the Internet.

You can specify the IP address of the primary/secondary DNS server.

See also: [DynDNS](#).

Domain name

Name of one (several) Web server(s) on the Internet (e.g. gigaset.net). The domain name is assigned to the relevant IP address by DNS.

DSCP Differentiated Service Code Point
See [Quality of Service \(QoS\)](#).

DSL Digital Subscriber Line

Data transfer technology that allows Internet access with, for e.g. [1.5 Mbps](#) over a conventional telephone line. Prerequisites: DSL modem and the appropriate service offered by the Internet provider.

DSLAM Digital Subscriber Line Access Multiplexer
The DSLAM is a switch cabinet in an exchange at which all subscriber connectors converge.

DTMF Dual Tone Multi-Frequency
Another description for dual tone multi-frequency dialing (DTMF).

Dynamic IP address

A dynamic IP address is assigned to a network component automatically via **DHCP**. The dynamic IP address for a network component can change every time it registers or at certain time intervals.

See also: **Static IP address**

DynDNS Dynamic DNS
Domain names and IP addresses are assigned via **DNS**. For **Dynamic IP addresses** this service is enhanced with "DynamicDNS". This permits the use of a network component with a dynamic IP address as a **Server** on the **Internet**. DynDNS ensures that a service can always be addressed on the Internet at the same **Domain name**, regardless of the current IP address.

E

ECT Explicit Call Transfer
Participant A calls participant B. The participant puts the connection on hold and calls participant C. Rather than connect everyone in a three-party conference, A now transfers participant B to C and hangs up.

EEPROM Electrically Erasable Programmable Read Only Memory
Memory building block in your phone with fixed data (e.g. default and customized settings) and data saved automatically (e.g. entries to the list of callers).

Ethernet network

Wired **LAN**.

F

Firewall You can use a firewall to protect your network against unauthorized external access. This involves combining various measures and technologies (hard and/or software) to control the flow of data between a private network you wish to protect and an unprotected network (e.g., the Internet).

See also: **NAT**.

Firmware Software for a device in which basic information is stored for the device's function. To correct errors or update the device software, a new version of the firmware can be loaded into the device's memory (firmware update).

Flat rate Billing system for an **Internet** connection. The Internet provider charges a set monthly fee. There are no additional charges for the duration of the connection or number of connections.

Glossary

Fragmentation

Data packets that are too big are split into smaller packets (fragments) before they are transferred. They are put together again when they reach the recipient (defragmented).

Full duplex Data transmission is a mode in which data can be sent and received at the same time.

G

G.711 a law, G.711 μ law

Standard for a **Codec**.

G.711 delivers a very good voice quality that corresponds to that in the ISDN fixed line. As there is little compression, the necessary bandwidth is around 64 kbit/s per voice connection, but the delay caused by coding/decoding is only 0.125 ms.

"a law" describes the European standard and " μ law" describes the North American/Japanese equivalent.

G.722

Standard for a **Codec**.

G.722 is a **broadband** language codec with a bandwidth of 50 Hz to 7 kHz, a net transmission rate of 64 kbit/s per language connection and integrated speech pause recognition and comfort noise generation (silence suppression).

G.722 delivers very good voice quality. A higher sampling rate provides clearer and better voice quality than other codecs and enables a speech tone in High Definition Sound Performance (HDSP).

G.726

Standard for a **Codec**.

G.726 delivers a good voice quality. It is inferior to the quality with codec **G.711** but better than with **G.729**.

G.729A/B

Standard for a **Codec**.

The voice quality is more likely to be lower with G.729A/B. As a result of the high level of compression, the necessary bandwidth is only around 8 kbit/s per voice connection, but the delay is around 15 ms.

Gateway Connects two different **Networks**, e.g. a router as an Internet gateway.

For phone calls from **VoIP** to the telephone network, a gateway has to be connected to the IP network and the telephone network (gateway/VoIP provider). It forwards calls from VoIP to the telephone network as required.

Gateway provider

See **SIP provider**.

Global IP address

See **IP address**.

GSM Global System for Mobile Communication
Originally, a European standard for mobile networks. GSM can now be described as a worldwide standard. In the USA and Japan national standards are now more frequently supported than in the past.

H

Headset Combination of microphone and headphone. A headset makes using the speaker more convenient. There are headsets available that can be connected to the handset by a cable.

HTTP Proxy Server via which the **Network subscribers** can process their Internet traffic.

Hub Uses one **Infrastructure network** to connect several **Network subscribers**. All data sent to the hub by one network subscriber is forwarded to all network subscribers.

See also: **Gateway, Router**.

I

IEEE Institute of Electrical and Electronics Engineers
International body that defines standards in electronics and electro-technology, concerned in particular with the standardization of LAN technology, transmission protocols, data transfer rate and wiring.

Infrastructure network

Network with central structure: All **Network subscribers** communicate via a central **Router**.

Instant messaging

Service that uses a client program to allow chatting in real time, i.e. to send brief messages to other subscribers on the Internet.

Internet Global **WAN**. A series of protocols have been defined for exchanging data, known by the name TCP/IP.

Each **Network subscriber** is identifiable via his **IP address**. **DNS** assigns a **Domain name** to the **IP address**.

Important services on the Internet include the World Wide Web (WWW), e-mail, file transfer and discussion forums.

Internet Service Provider

Enables access to the Internet for a fee.

IP (Internet Protocol)

TCP/IP protocol on the **Internet**. IP is responsible for addressing subscribers in a **Network** using **IP addresses** and transfers data from the sender to the recipient. IP determines the paths (routing) along which the data packets travel.

Glossary

IP address A unique address for a network component within a network based on the TCP/IP protocols (e.g. LAN, Internet). On the **Internet**, domain names are usually assigned instead of IP addresses. **DNS** assigns the corresponding IP address to the domain name.

The IP address has four parts (decimal numbers between 0 and 255) separated by periods (e.g. 230.94.233.2).

The IP address is made up of the network number and the number of the **Network subscriber** (e.g. phone). Depending on the **Subnet mask**, the front one, two or three parts make up the network number and the rest of the IP address addresses the network component. The network number of all the components in any one network must be identical.

IP addresses can be assigned automatically with DHCP (dynamic IP addresses) or manually (static IP addresses).

See also: **DHCP**.

IP pool range

Range of IP addresses that the DHCP server can use to assign dynamic IP addresses.

L

LAN Local Area Network

Network with a restricted physical range. A LAN can be wireless (WLAN) and/or wired.

Local IP address

The local or private IP address is the address for a network component in the local network (LAN). The network operator can assign any address he or she wants. Devices that act as a link from a local network to the Internet (gateway or router) have a public and a private IP address.

See also **IP address**.

Local SIP Port

See **SIP port/Local SIP port**.

M

MAC address

Media Access Control Address

Hardware address by means of which each network device (e.g. network card, switch, phone) can be uniquely identified worldwide. It consists of 6 parts (hexadecimal numbers) separated by a "-" (e.g. 00-90-65-44-00-3A).

The MAC address is assigned by the manufacturer and cannot be changed.

Mbps Million bits per second

Unit of the transmission speed in a network.

MRU Maximum Receive Unit
Defines the maximum user data volume within a data packet.

MTU Maximum Transmission Unit
Defines the maximum length of a data packet that can be carried over the network at a time.

Music on hold

Music that is played while you are on a **Consultation call** or **Call swap**. The waiting participant hears music while on hold.

N

NAT Network Address Translation
Method for converting (private) **IP addresses** to one or more (public) IP addresses. NAT enables the IP addresses of **Network subscribers** (e.g. VoIP telephones) in a **LAN** to be concealed behind a shared IP address for the **Router** on the **Internet**.

VoIP telephones behind a NAT router cannot be reached by VoIP servers (on account of the private IP address). To "get around" NAT, it is possible to use (alternately) **ALG** in the router, **STUN** in the VoIP telephone, or for the VoIP provider to use an **Outbound proxy**.

If an outbound proxy is made available you must allow for this in the VoIP settings for your phone.

Network Group of devices. Devices can be connected in either wired or wireless mode. Networks can also differ in range and structure:

- Range: local networks (**LAN**) or wide-area networks (**WAN**)
- Structure: **Infrastructure network** or ad-hoc network

Network subscriber

Devices and PCs that are connected to each other in a network, e.g. servers, PCs and phones.

O

Outbound proxy

Alternate NAT control mechanism to STUN and ALG.

Outbound proxies are implemented by the VoIP provider in firewall/NAT environments as an alternate to **SIP proxy server**. They control data traffic through the firewall.

Outbound proxy and STUN servers should not be used simultaneously.

See also: **STUN** and **NAT**.

Glossary

P

- Paging** (handset search)
A base station function to locate registered handsets. The base station establishes a connection to every registered handset. The handsets start to ring. Paging is activated by briefly pressing the button on the base station and is deactivated by briefly pressing the same button again.
- PIN** Personal Identification Number
Protects against unauthorized use. When the PIN is activated, a number combination has to be entered to access a protected area.
You can protect your base station configuration data with a system PIN (4-digit number combination).
- Port** Data is exchanged between two applications in a **Network** via a port.
- Port forwarding**
The Internet gateway (e.g. your router) forwards data packets from the **Internet** that are directed to a certain **Port** to the port concerned. This allows servers in the **LAN** to offer services on the Internet without you needing a public IP address.
- Port number**
Indicates a specific application of a **Network subscriber**. Depending on the setting in the **LAN**, the port number is permanently assigned or else it is newly assigned with each access.
The combination of **IP address/Port** number uniquely identifies the recipient or sender of a data packet within a network.
- Predialing** See **Block dialing**.
- Private IP address**
See **Public IP address**.
- Protocol** Describes the agreements for communicating within a **Network**. It contains rules for opening, administering and closing a connection, about data formats, time frames and possible error handling.
- Proxy/Proxy server**
Computer program that controls the exchange of data between **Client** and **Server** in computer networks. If the phone sends a query to the VoIP server, the proxy acts as a server towards the phone and as a client towards the server. A proxy is addressed via **IP addresses/Domain names** and **Ports**.
- Public IP address**
The public IP address is the address for a network component on the Internet. It is assigned by the Internet Service Provider. Devices that act as a link from a local network to the Internet (gateway, router) have a public and a local IP address.
See also: **IP address, NAT**

Q**Quality of Service (QoS)**

Quality of service

Describes the Quality of Service in communication networks. Differentiations are made between various Quality of Service classes.

QoS influences the flow of data packets on the Internet, e.g. by prioritizing data packets, reserving bandwidth and data packet optimization.

In VoIP networks, QoS influences the voice quality. If the whole infrastructure (router, network server, etc.) has QoS, the voice quality is better, i.e. fewer delays, less echoing, less crackling.

R**RAM** Random Access Memory

Memory in which you have reading and storage rights. Items such as melodies and screen pictures are saved in the RAM after you have loaded them onto the phone via the Web configurator.

Registrar The registrar manages the **Network subscribers'** current IP addresses. When you register with your VoIP provider, your current IP address is saved on the registrar. This means you can also be reached when on the move.

Ringback when the call is not answered

= CCNR (Completion of Calls on No Reply). If a participant does not respond when called, a caller can arrange an automatic ringback. As soon as the destination phone has completed a call and is free again, the caller is rung back. This feature must be supported by the exchange. The ringback request is automatically canceled after about 2 hours (depending on the VoIP provider).

Ringback when the number is busy

= CCBS (Completion of Calls to Busy Subscriber). If a caller hears the busy tone, he or she can activate the ringback function. As soon as the connection is free the caller is rung back. As soon as the caller lifts the receiver the connection is made automatically.

ROM Read Only Memory

A type of memory that can only be read.

Router Routes data packets within a network and between different networks via the quickest route. Can connect **Ethernet networks** and WLAN. Can be a **Gateway** to the Internet.

Glossary

Routing Routing is the transfer of data packets to another subscriber in your network. On their way to the recipient, the data packets are sent from one router to the next until they reach their destination.

If data packets were not forwarded in this way, a network like the Internet would not be possible. Routing connects the individual networks to this global system.

A router is a part of this system; it transfers data packets both within a local network and from one network to the next. Transfer of data from one network to another is performed on the basis of a common protocol.

RTP Realtime Transport Protocol
Global standard for transferring audio and video data. Often used in conjunction with UDP. In this case, RTP packets are embedded in UDP packets.

RTP port (Local) **Port** that is used to send and receive voice data packets for VoIP.

S

Server Provides a service to other **Network subscribers (Clients)**. The term can indicate a computer/PC or an application. A server is addressed via **IP addresses/ Domain names** and **Ports**.

SIP (Session Initiation Protocol)

Signaling protocol independent of voice communication. Used for establishing and ending a call. It is also possible to define parameters for voice transmission.

SIP address

See **URI**.

SIP port/Local SIP port

(Local) **Port** that is used to send and receive SIP signaling data for VoIP.

SIP provider

See **VoIP provider**.

SIP proxy server

IP address of your VoIP provider's gateway server.

Static IP address

A static IP address is assigned to a network component manually during network configuration. Unlike a **Dynamic IP address**, a static IP address does not change.

STUN Simple Transversal of UDP over NAT

NAT control mechanism.

STUN is a data protocol for VoIP telephones. STUN replaces the private IP address in the data packets of the VoIP telephone with the public address of the secure private network. To control data transfer, a STUN server is also required on the Internet. STUN cannot be implemented with symmetric NATs.

See also: **ALG, Firewall, NAT, Outbound proxy**.

Subnet Segment of a **Network**.

Subnet mask

IP addresses consist of a fixed network number and a variable subscriber number. The network number is identical for all **Network subscribers**. The size of the network number part is determined in the subnet mask. In the subnet mask 255.255.255.0, for example, the first three parts of the IP address are the network number and the last part the subscriber number.

Symmetric NAT

A symmetric NAT assigns different external IP addresses and port numbers to the same internal IP addresses and port numbers – depending on the external target address.

T

TCP Transmission Control Protocol

Transport protocol. Session-based transmission protocol: it sets up, monitors and terminates a connection between sender and recipient for transporting data.

TLS Transport Layer Security

Protocol for encrypting data transmissions on the Internet. TLS is a superordinated **Transport protocol**.

Transmission rate

Speed at which data is transmitted in the **WAN** or **LAN**. The transmission rate is measured in data units per unit of time (Mbit/s).

Transport protocol

Controls data transport between two communication partners (applications).

See also: **UDP**, **TCP**, **TLS**.

U

UDP User Datagram Protocol

Transport protocol. Unlike **TCP**, **UDP** is a non session-based protocol. UDP does not establish a fixed connection. The data packets ("datagrams") are sent as a broadcast. The recipient is solely responsible for making sure the data is received. The sender is not notified about whether it is received or not.

URI Uniform Resource Identifier

Character sequence for identifying resources (e.g. e-mail recipient, http://gigaset.com, files).

On the **Internet**, URIs are used as a uniform identification for resources. URIs are also described as SIP addresses.

URIs can be entered in the phone as a number. By dialing a URI you can call an Internet subscriber with VoIP equipment.

Glossary

URL Universal Resource Locator
Globally unique address of a domain on the **Internet**.
A URL is a subtype of **URI**. URLs identify a resource by its location on the **Internet**. For historical reasons the term is often used as a synonym for URI.

User ID See **User identification**.

User identification

Name/number combination for access, e.g. to your VoIP account.

V

Voice codec

See **Codec**.

VoIP Voice over Internet Protocol

Telephone calls are no longer placed and transmitted over the telephone network but over the **Internet** (or other IP networks).

VoIP provider

A VoIP, SIP or **Gateway provider** is an Internet service provider that provides a **Gateway** for Internet telephony. As the phone works with the SIP standard, your provider must support the SIP standard.

The provider routes calls from VoIP to the telephone network (analog, ISDN and cellular) and vice versa.

W

WAN Wide Area Network

Wide-area network that is unrestricted in terms of area (e.g. **Internet**).

Index

A

- Access code (PABX) 142
- Access protection 132
- Access to Web configurator
 - from other networks 152
- Accessories 223
- Account name (e-mail) 181
- Acknowledge tones 129
- Activating
 - advisory tones 129
 - annex B for G.729 166
 - answering machine 97
 - answering machine from external
 - location 105
 - appointment 110
 - auto answer 126
 - call forwarding (VoIP) 61
 - handset 1, 37
 - keypad lock 37
 - network mailbox 106, 174
 - room monitor 119
 - speaker 53
 - two-way record 101
 - withholding phone numbers 60
- Address assignment (IP address) 151
- ADSL 224
- Advisory tones 129
- Alarm clock 112
- Alert tone
 - activating/deactivating 128
- ALG 224
- Alternate DNS server
 - (Web configurator) 152
- Anniversary
 - deactivating 75
 - displaying missed ones 111
 - missed 75, 111
 - storing 74
- Announce only mode
 - (ans. mach.) 96
- Announcement (answering
 - machine) 99
- Anonymous calling 60
- Answer and record mode
 - (ans. mach.) 96
- Answering machine 96
 - activating/deactivating 97
 - assigning receive numbers 170
 - deleting messages 101
 - playing back messages 99
 - record announcement/
 - notification 98
 - remote operation 104
 - scrolling back 100
 - scrolling forward 100
- Answering Machine list 68
- Application Layer Gateway (ALG) 224
- Application signal (Flash key) 176
- Application type (Flash key) 176
- Appointment call 111
- Appointments 110
 - activating/deactivating 111
 - deleting 111
 - displaying missed ones 111
 - managing 111
- Arabic characters, entering 148
- Area code
 - dialing automatically 171
 - entering own 171
 - setting own area code 131
- Area code predialing
 - activating/deactivating 171
- Area codes 135
 - extra area codes 135
 - extra codes 135
 - local area code 135
 - own area code 135
- Assigning a key 124
- Assigning send number to
 - handset 168
- Asterisk key 1, 128
- Asymmetric Digital Subscriber
 - Line 224
- Attaching the belt clip 32
- Audio (DTMF signaling) 175
- Authentication 224
- Authentication name
 - e-mail 181
- Auto answer 49
 - activating/deactivating 126
- Auto-configuration code 24, 156
- Automatic configuration
 - of a VoIP connection 24, 156
- Automatic redial 65
- Automatic version check 187

Index

- Available codecs 166
- Away from computer (messenger) . . . 83
- B**
- Base station
 - activating/deactivating
 - eco mode 109
 - best base station 115
 - changing system PIN. 132
 - checking service information. 197
 - connecting 19
 - connecting to electrical power
 - supply 21
 - connecting to fixed line network . . . 21
 - connecting to router 23
 - operating on PABX 141
 - power consumption 201
 - reducing power consumption 109
 - reducing transmission power 109
 - restoring factory settings 133
 - selecting 115
 - setting 132
 - setting default connection . . . 134, 167
 - setting up. 19
 - system PIN 133
 - updating firmware 136, 185
 - wall mounting 250
- Base station selection. 115
- Battery
 - charge status 2
 - charging. 1, 15
 - display 1, 15
 - icon 1, 15
 - inserting 14
 - recommended batteries 200
 - tone 129
- Beep 128
- Best base station 115
- Birthday, see Anniversary
- Block dialing 224
- Blocking your caller ID 60
- Broadband connections 11
- Broadband Internet access 224
- Broadband voice codec 164, 228
- Browser
 - operating 93
- Buddy 81, 224
 - buddy messages 87
 - calling 89
 - checking information 86
 - list 81
 - opening list 84
 - status changes. 85
- Busy (messenger) 83
- Buttons (Web configurator) 149
- C**
- Calendar. 110
- Call
 - accepting 49
 - disconnecting (call swap) 63
 - ending 48
 - external. 51
 - incoming. 2
 - internal 116
 - number/name display 49
 - picking up from answering
 - machine 101
 - rejecting external. 118
 - transfer (VoIP) 63
 - transferring (connecting) 117
 - two-way record 101
- Call acceptance
 - automatic 126
- Call display 50
 - fixed line network 50
 - VoIP 50
- Call duration display 76
- Call forwarding 224, 225
 - Gigaset.net 61, 170
 - VoIP (handset) 61
 - VoIP (Web configurator) 170
- Call screening during recording 102
- Call swap 225
 - disconnecting call 63
 - VoIP 63
- Call transfer
 - VoIP 63
- Call waiting 225, 226
 - accepting/rejecting (VoIP). 64
 - activating/deactivating (VoIP) 62
 - internal call 118
- Call-by-call numbers 71, 76
- Caller ID 49
- Calling
 - anonymously. 60
 - entering IP address 47
 - external. 45
 - Gigaset.net 57, 59
 - internal 116

- via VoIP/fixed line network 45
 - Calls list 67
 - Cancel operation 35
 - Canceling
 - dialing 47
 - operation 35, 149
 - Care of the telephone 200
 - Changing
 - dialing mode 141
 - earpiece volume 126
 - internal number 115, 182
 - speaker volume 126
 - system PIN 133
 - Changing PIN
 - system PIN 133
 - Changing to daylight saving time . . . 188
 - Character set table, see Special characters
 - Charge saving function (remote operation) 103
 - Charge status display (battery) 1, 15
 - Charge status of the batteries 2
 - Charging cradle
 - connecting 15, 250
 - wall mounting 250
 - Chatting 81, 225
 - with buddies 86
 - Checking EEPROM version 189
 - Checking service information 197
 - CID picture 49, 71, 130
 - Client 225
 - Codecs 225
 - Codecs, available 166
 - Color scheme (display) 122
 - COLP 52, 225
 - COLR 52, 225
 - Conference 117
 - Conference call
 - fixed line network 61
 - VoIP 63
 - Configuration
 - via PC 144
 - VoIP connection (automatic) 156
 - Configuring
 - VoIP connection (handset) 138
 - VoIP connection (Web config.) 154
 - Confirmation tone 129
 - Connected Line Identification
 - Presentation/Restriction 52, 225
 - Connecting
 - to the Web configurator 145
 - Connecting phone to internal company network 153
 - Connecting the PC to the Web configurator 144
 - Connection
 - activating (VoIP) 162
 - Internet (troubleshooting) 30
 - name/provider (Web config.) 154
 - selecting (line suffix) 45, 47
 - to Gigaset.net 163
 - Connection assistant
 - starting (getting started) 24
 - Connection name
 - fixed line network 162
 - VoIP 156
 - Connection socket for headset 1, 32
 - Connection to an internal company network 153
 - Connection to message server 82
 - Connection type
 - selecting (Display key) 45, 46
 - selecting (Talk key) 45
 - Consultation call 225
 - ending 117
 - external (fixed line network) 61
 - external (VoIP) 63
 - internal 34, 117
 - Contrast (display) 122
 - Control key 1
 - functions 34
 - Correcting incorrect entries 35
 - Cost control 9, 76
 - defining dialing plans 172
 - Customer Care 211
 - Customer Service 190
 - CW 226
 - Cyrillic characters, entering 148
- ## D
- Data packets, fragmentation 228
 - Data server for firmware update 185
 - Date
 - set manually 16
 - transferring from time server 187
 - Daylight saving time
 - changing automatically 188
 - Deactivating
 - advisory tones 129
 - answering machine 97
 - appointment 110

Index

- appointment reminder 111
- auto answer 126
- call forwarding (VoIP) 61
- handset 1, 37
- keypad lock 37
- network mailbox 106, 174
- room monitor 120
- speaker 53
- two-way record 101
- withholding phone numbers 60
- Default settings
 - handset 131
- Delete key 35
- Deleting
 - announcement for answering
 - machine 99
 - message 101
 - Deleting an e-mail 80
 - Deleting characters 35
 - Demilitarized Zone 226
 - De-registering
 - from Web configurator 146
 - handset from base station 114
 - Destination number (room
 - monitor) 119
 - DHCP 226, 227
 - Dialing
 - canceling 47
 - IP address 47
 - using Quick dial 73, 124
 - with directory 72
 - Dialing plans 9, 76, 172
 - activating/deactivating 173
 - defining 172
 - deleting 173
 - for emergency numbers 174
 - Differentiated Service Code Point 226
 - Digit key
 - assigning a number/function 124
 - changing assignment 125
 - Digital Subscriber Line 226
 - Access Multiplexer 227
 - Directory 70
 - copying number 74
 - deleting (Web configurator) 184
 - editing via PC 183
 - Gigaset.net 56
 - loading from PC 184
 - opening 34
 - order of entries 205
 - saving anniversary 74
 - saving entry 71
 - selecting entry 72
 - sending entry/list to handset 73
 - transferring to/from PC 183
 - using to enter numbers 74
 - Directory file
 - content (vCard format) 184
 - Display
 - appointment/alarm
 - activated 2
 - backlight 123
 - call duration 76
 - caller's number (CID) 49
 - changing display language 121
 - charge status of the batteries 2
 - color scheme/contrast 122
 - in idle status 1
 - incoming call 2
 - keypad lock 2
 - memory (directory) 73
 - missed appointment/
 - anniversary 111
 - name (CNIP) 52
 - ringer deactivated 2
 - screensaver 122
 - setting 122
 - wrong language 121
 - Display keys 1, 35
 - assigning a number/function 124
 - changing assignment 125
 - Displayed name (VoIP) 159, 226
 - Disposal 199
 - DMZ 226
 - DNS 226
 - DNS server
 - alternate (Web configurator) 152
 - preferred (handset) 140
 - preferred (Web configurator) 152
 - Do not disturb (messenger) 83
 - Domain 159
 - Domain name 226
 - Domain Name System 226
 - DSCP 226
 - DSL 226
 - DSLAM 227
 - DTMF (tone dialing) 143
 - DTMF signaling for VoIP 175
 - Dynamic DNS 227

Dynamic Host Configuration
 Protocol 226
 Dynamic IP address 151, 227
 DynDNS. 227

E

Earpiece mode 53
 Earpiece volume 126
 EATONI (predictive text) 203
 Echo service of Gigaset.net. 54
 ECO DECT 109
 Eco mode 109
 E-mail
 account name 181
 authentication name/password . . . 181
 e-mail list 77
 entering access data 181
 incoming e-mail server 181
 messages while making
 a connection 78
 notification 77
 settings (Web config.) 181
 viewing the sender's address 80
 Emergency number
 dialing 48
 when keypad lock is active 8
 Emergency numbers
 dialing plans for 174
 End Call key 1, 47, 48
 Ending, call 48
 Entering access data
 (e-mail) 181
 Entering Cyrillic/Arabic
 characters 148
 Entering flash 1
 Entering pause 1
 Entering user data (VoIP)
 with handset 27
 Error handling
 messenger 90
 Error tone 129
 Ethernet network 227
 Example
 menu input 37
 Explicit Call Transfer 227
 External call
 accepting 49
 forwarding to ans. mach. 101

External consultation call
 fixed line network 61
 VoIP 63
 External line prefix (PABX) 142
 Extra area codes 135
 Extra codes 135

F

Factory settings
 base station 133
 Fast access 107
 answering machine 104
 directory entries 73
 Firewall 227
 Firmware 227
 automatic update 136, 187
 checking version 189, 198
 starting update (handset) 136
 starting update (Web conf.) 185
 updates 13
 Fixed line network
 anonymous calling 60
 conference call 61
 connection name 162
 entering network mailbox 106
 external consultation call 61
 settings for calls 61
 withholding phone numbers 60
 Fixed line network connection
 line suffix 155
 Flash 117
 Flash key 1
 function for VoIP 175
 Flat rate 227
 Fragmentation of data packets 228
 Free software, licenses 215
 Full duplex 228

G

G.711 μ law 164
 G.711 a law 164
 G.722 11, 164
 G.722 Broadband language
 codec 164
 G.726 164
 G.729 164
 Gateway 228
 Gateway provider 228
 Getting help with your phone 190
 Gigaset config. 144, 145

Index

Gigaset HDSP see HDSP
 Gigaset.net 54
 (de)activating connection 163
 call forwarding 61, 170
 calling participant 57, 59
 changing/deleting own name 58
 directory 56
 Echo service 54
 entering name 55, 58
 Jabber server 180
 messaging 180
 searching for subscriber 56
 Global IP address 228
 Global System for
 Mobile Communication 229
 GNU Lesser General Public
 License 215
 Going online (messenger) 82
 Group call 116
 GSM 229

H

Handset
 activating/deactivating 1, 37
 activating/deactivating
 advisory tones 129
 assigning receive number 168
 assigning send number 168
 base station selection 115
 changing internal names 116, 182
 changing internal number 115, 182
 changing name 116, 182
 changing to a different base
 station 115
 changing to best reception 115
 checking service information 198
 contact with liquid 200
 de-registering 114
 display backlight 123
 display language 121
 earpiece volume 126
 forwarding a call 117
 handset volume 126
 idle status 37
 list 34, 183
 locating 114
 muting 54
 operating 34
 registering 18, 113
 resetting 132

restoring to factory settings 131
 screensaver 122
 setting (individual) 121
 setting up 14
 speaker volume 34
 using room monitor 118
 using several 113
 volume 34
 Handset directory see Directory
 Handset operating time
 in room monitor mode 118
 Handset operating times 201
 HDSP 9, 11, 164
 Headset 1, 32, 229
 Hearing aids 8
 Help 190
 High Definition Sound Performance
 see HDSP
 HTTP Proxy 153, 229
 Hub 229

I

Icon
 alarm clock 112
 answering machine 97
 battery 15
 new message 99
 new messenger message 86
 ringer deactivated 128
 Idle status
 back to 37
 display 1
 IEEE 229
 Incoming e-mail server (e-mail) 181
 Incoming Mail list
 opening (e-mail) 77
 Incorrect input (correction) 35
 Info Center 91
 Info messages (messenger) 87
 Info services 181
 configuring 181
 Infrastructure network 229
 Input language (message) 204
 Installing, base station 19
 Instant messaging 81, 179, 229
 prerequisites 81
 Institute of Electrical and
 Electronics Engineers 229

- Interface language
 - handset 121
 - Web configurator 146
- Internal call 116
 - call waiting. 118
- Internal company network 153
- Internal consultation call 34, 117
- Internet 229
 - no connection to 30
- Internet access (broadband) 224
- Internet protocol 229
- Internet Service Provider 229
- Intranet 153
- IP 229
- IP address 230
 - assigning (handset) 139
 - assigning (Web configurator) 151
 - checking (handset) 139
 - checking (Web configurator) 189
 - dialing 47
 - display on handset 2
 - dynamic 227
 - global 228
 - local 230
 - obtaining automatically 139, 151
 - private 232
 - public 232
 - static 234
 - type 139, 151
- IP configuration
 - handset 139
 - Web configurator 151
- IP pool range 230
- J**
- Jabber ID (messenger) 179
- Jabber server (messenger) 179
- Jabber server port (messenger) 180
- K**
- Key 1 (fast access)
 - assigning 107
- Key 1 (quick dial) 1, 104
- Key click 129
- Keypad lock 8, 37
- Keys
 - assigning directory entry 73
 - Asterisk key 1, 128
 - Cancel key 35
 - Control key 1, 34
 - Delete key 35
 - Display keys 1, 35
 - End Call key 1, 47, 48
 - Flash key 1
 - Keypad lock 37
 - Message key 1, 66
 - On/Off key 1
 - Paging key (base station) 2
 - Pound key 1, 37
 - Quick dial 1, 73, 104
 - Quick list 1
 - Speaker key 1
 - Talk key 1
- L**
- LAN 230
- Language
 - handset/display 121
 - Web configurator 146
- Last number redial 65
- LGPL 215
- Licenses, free software 215
- Line suffix
 - dialing with 45, 47
 - display (Web configurator) 155
- Line type
 - for outgoing calls 167
- Liquid 200
- List
 - Answering Machine list 68
 - Calls List 67
 - e-mail notifications 77
 - handsets 34, 183
 - Last Number Redial list 65
 - Missed Calls 67
 - Network Mailbox 108
- Local area code 135
- Local Area Network 230
- Local communication ports 177
- Local IP address 230
- Local network 151
- Local SIP port 234
- Local SIP port (keypad lock) 37
- Login password
 - e-mail 181
 - messenger 179
- Lost connection
 - messenger 83, 90

Index**M**

MAC address 230
 checking (handset) 141
 checking (Web configurator) 189

Mailbox
 defining for fast access 107

Main menu 36, 40

Making calls
 accepting a call. 49
 external (VoIP, fixed line network) 45
 internal 116

Making cost-effective calls 76

Making internal calls 116

Maximum Receive Unit. 231

Maximum Transmission Unit. 231

Mbps. 230

Media Access Control 230

Medical appliances. 8

Memory
 directory 73

Menu
 end tone 129
 going back one menu level 35
 menu guidance 36
 menu input 37
 opening 34
 phone overview 40
 Web configurator overview 44

Menu bar (Web configurator) 147

Message
 Answering Machine list 68
 deleting (answering machine) 101
 deleting (e-mail) 80
 deleting (messenger) 88
 marking as "new" (answering machine) 100
 new message icon 99
 playback via remote operation. 105
 playing (network mailbox) 108
 playing back (answering machine) 69, 99
 receiving (messenger) 86
 writing/sending (messenger) 88

Message key 1
 opening lists 66

Message list
 answering machine 68, 99
 e-mail 77
 messenger 87

network mailbox 108

Message server 81
 establishing a connection. 82

Messaging
 Gigaset.net 180

Messenger 81
 account. 179
 calling buddy. 89
 changing own status 83
 entering access data 179
 error handling 90
 errors when sending 90
 lost connection 83, 90
 message list. 87
 priority 179
 resource name. 179

Messenger message
 deleting. 88
 reading 88
 receiving 86
 writing/sending 88

Microphone 1

Million bits per second 230

Missed
 anniversary 111
 appointment 111

Missed calls 67

MRU 231

MTU 231

Music 231

Music on hold. 53, 54, 134, 231

Muting the handset. 54

Muting the microphone. 53, 54

My stuff 130

N

Name
 changing name of the handset 116, 182
 displayed (VoIP) 226
 displaying caller's name (CNIP) 52
 fixed line network connection 162

NAT 231
 symmetric 235
 updating 161

Navigation area
 (Web configurator) 148

Network 231
 Ethernet 227

Network Address Translation 231

Network area 160
 Network mailbox 106
 activating/deactivating 106, 174
 calling 108
 defining for fast access 107
 entering number 106, 174
 list 108
 Network MB, see network mailbox
 Network provider (numbers list) 71
 Network services
 fixed line network 61
 fixed line network and VoIP 60
 settings for fixed line
 network calls 61
 settings for VoIP calls 61, 62
 VoIP 61
 Notification
 incoming e-mail 77
 Number
 as destination for room monitor . . 119
 copying from directory 74
 copying to directory 74
 displaying caller's number (CID) . . 49
 entering network mailbox
 number 106, 174
 entering with directory 74
 saving in the directory 71
 Number assignment 169, 170
 Numbers list, network provider 71
O
 Offline (messenger) 81, 83
 On/Off key 1
 Online (messenger) 81, 83
 Online directory
 Gigaset.net 56
 Opening the Incoming Mail list 77
 Opening/closing the battery cover . . 14
 Operation (preparing to use
 the phone) 12
 Order in directory 205
 Outbound proxy 161, 231
 mode 161
 port 161
 Own area code
 area code 135
 entering 171
 setting 131

P

PABX
 access code (external line
 prefix) 142
 operating base station on PABX . . 141
 pauses 142
 setting dialing mode 141
 setting Flash 141
 Pack contents 12
 Paging 2, 114, 232
 Pauses (PABX) 142
 Personal Identification Number 232
 Personal provider data 158
 Phone
 configuring via PC 144
 menu overview 40
 protecting (PIN) 132
 setting (Web configurator) 150
 setting base station
 (on handset) 132
 setting up 12
 Phone connection
 configuring (handset) 137
 Phone functions, overview 40
 Phone jack pin connections 202
 Phone status (Web configurator) . . . 189
 Picture
 deleting 130
 renaming 130
 Picture CID, see CIDpicture
 PIN 232
 changing 132
 Playback (ans. mach.) 68
 remote operation 105
 Playing back
 announcement (answering
 machine) 99
 message (answering machine) 99
 POP3 server 181
 Port 232
 Port forwarding 232
 Port number 232
 Pound key 1, 37
 Power adapter 8
 Power consumption
 of base station 201
 reducing for the base station 109
 Predialing 232
 Predictive text 203

Index

- Preferred DNS server
 - entering (handset) 140
 - entering (Web configurator) 152
- Priority (messenger) 179
- Private IP address 232
- Problems and solutions 190
- Protocol 232
- Proxy 232
- Proxy server address 159
- Proxy-Server 232
- Public IP address 232
- Q**
- Quality of Service 233
- Questions and answers 190
- Quick dial 70, 124
- Quick dial keys 73
- Quick list 70
 - key 1
- R**
- RAM 233
- Random Access Memory 233
- Read Only Memory 233
- Reading message (messenger) 88
- Reading the subject (e-mail) 79, 80
- Ready to chat (messenger) 83
- Receive number
 - answering machine 96
 - assigning to answering machine 170
 - assigning to handset 168
 - display on the handset 50
- Recording
 - announcement/notification (ans. mach.) 98
 - two-way record 101
- Recording quality (ans. mach.) 103
- Recording time (ans. mach.) 103
- Registering
 - handset 18, 113
 - with the Web configurator 146
- Registrar 233
- Registrar server 159
- Registrar server port 159
- Registration name
 - VoIP account 139, 158
- Registration password
 - VoIP account 27, 139, 158
- Registration refresh time 159
- Reminder call (anniversary) 75
- Remote access to Web configurator 152
- Remote management 152
- Remote operation 104
- Resetting
 - base station 133
 - handset 131
- Resource name (messenger) 179
- RFC 2833 (DTMF signaling) 175
- Ring delay 103
- Ringback
 - initiating (fixed line network) 61
 - when busy 233
 - when the call is not answered 233
- Ringer
 - changing 127
 - deactivating permanently 128
 - icon 2
 - muting 49
 - setting 127
 - setting volume 127
- ROM 233
- Room monitor 118
- Router 233
 - connecting base station 23
- Routing 234
- RTP 234
- RTP port 178, 234
- S**
- Safety precautions 8
- Scope of delivery 12
- Screensaver 122
- Search for subscriber on Gigaset.net 56
- Searching
 - handset 114
 - in directory 72
- Selecting announcement mode (ans. mach.) 97
- Send number
 - selecting via line suffix 47
- Sender's address (e-mail) 80
- Sensitivity (room monitor) 119
- Server 234
 - for firmware update 185
- Server port 159
- Service (Customer Care) 211

- Setting
 - base station 132
 - date/time on handset 16
 - handset 121
 - screensaver 122
 - Setting default connection 134, 167
 - Setting Flash (PABX) 141
 - Setting ringer 127
 - Setting the time zone 188
 - Settings for VoIP telephony 156
 - Shortcut (digit combination) 40
 - Signal strength 1
 - Signal tone, see Advisory tones
 - Simple Transversal of UDP over
 - NAT 234
 - SIP 234
 - SIP address 234
 - SIP Info (DTMF signaling) 175
 - SIP port 178, 234
 - SIP provider 234
 - SIP proxy server 234
 - Snooze (alarm clock) 112
 - Snooze mode (alarm clock) 112
 - Sound, see Ringer
 - Speaker 53
 - activating/deactivating 53
 - key 1
 - mode 53
 - Special characters 202
 - Specifications 200
 - Standard gateway
 - entering (handset) 140
 - entering (Web configurator) 151
 - Starting connection assistant
 - (menu) 137
 - State of presence (messenger) 81, 83
 - setting own 83
 - Static IP address 151, 234
 - Status
 - buddy 81
 - changing own (messenger) 83
 - VoIP connection 155
 - Status codes
 - activating display (Web config.) 185
 - Status codes (VoIP)
 - activating display (handset) 140
 - codes table 194
 - Structure of IP address 230
 - STUN 234
 - STUN port 160
 - STUN refresh time 161
 - STUN server 160
 - Submenu 36
 - Subnet 235
 - Subnet mask 235
 - defining (handset) 140
 - defining (Web configurator) 151
 - Suffix 155
 - dialing with 45, 47
 - Suppressing
 - speech pauses (VoIP) 166
 - Suppressing silence 166
 - Suppressing speech pauses 166
 - Symmetric NAT 235
 - Synchronization with time server 187
 - System settings 132
- T**
- Talk key 1
 - TCP 235
 - Telephone connection
 - configuring (Web config.) 154
 - Telephone jack pin connections 202
 - Text information
 - in idle display mode 181
 - Time
 - set manually 16
 - transferring from time server 187
 - Time server 187
 - TLS 235
 - Tone dialing 143
 - Transferring PC address book
 - to directory 183
 - Transmission Control Protocol 235
 - Transmission power
 - reducing for the base station 109
 - Transmission rate 235
 - Transport Layer Security 235
 - Transport protocol 235
 - Troubleshooting 190
 - e-mail 78
 - general (table) 190
 - Internet connection 30
- U**
- UDP 235
 - Uniform Resource Identifier 235
 - Universal Resource Locator 236
 - Unknown 51
 - Unknown caller 51

Index

URI 235
 Use random ports 178
 User Datagram Protocol 235
 User ID 236
 User identification 236
 User name (VoIP-Account) 138, 158

V

vCard format 185
 vcf file 183
 Version check, automatic 187
 VIP (directory entry) 73
 Voice over Internet Protocol 10, 236
 Voice quality 163
 Voice quality and infrastructure . . . 167
 VoIP 236
 accepting/rejecting call waiting . . . 64
 activating/deactivating call
 waiting 62
 activating/deactivating network
 mailbox 106
 activating/deactivating status
 message 140
 advantages. 10
 anonymous calling 60
 assigning IP address 139
 call forwarding 61
 call swap 63
 call transfer 63
 completing settings 29
 conference call 63
 configuring account 156
 configuring account (first) 27
 connection name 156
 displaying called party's number . . . 52
 entering network mailbox 106
 external consultation call 63
 loading provider data . . . 26, 137, 157
 making call settings 61
 network services. 61
 phone number 29, 156
 prerequisites. 10
 settings (on handset) 137
 starting connection
 assistant 24, 137
 status codes (table) 194
 withholding phone numbers. 60
 VoIP connection
 activating/deactivating 155, 162
 automatic configuration 156

 configuring (handset) 137
 configuring (Web configurator) . . . 156
 line suffix 155
 name (Web configurator) 156
 name/provider (Web config.) 154
 VoIP provider 236
 downloading data 26, 137, 157
 selecting (handset) 26, 137
 selecting (Web configurator) 157
 VoIP status messages
 activating display (handset) 140
 activating display (Web config.) . . 185
 status codes table 194
 VoIP telephony
 settings (Web config.) 156
 VoIP user data
 entering (connection assistant) . . . 27
 entering (handset) 138
 entering (Web configurator) 158
 Volume
 earpiece volume 34, 126
 handset. 126
 handsfree 34, 126
 ringer 127

W

Wall mounting
 base station. 250
 charging cradle 250
 WAN. 236
 Warning tone, see Advisory tones
 Weather forecasts, in idle
 display mode 95, 181

- Web configurator 144
 - activating VoIP connection 155
 - alternate DNS server 152
 - assigning receive number . . . 168, 170
 - assigning receive number to
 - ans. mach. 170
 - assigning send number 168
 - checking EEPROM version 189
 - checking firmware version 189
 - checking IP address 189
 - checking MAC address 189
 - connecting with PC 144
 - creating e-mail settings 181
 - deactivating VoIP connection 155
 - defining IP address 151
 - defining standard gateway 151
 - de-registering 146
 - directory transfer 183
 - DTMF signaling for VoIP 175
 - firmware update 185
 - interface language 146
 - IP configuration 151
 - local network 151
 - menu 44
 - messenger access data 179
 - name of a VoIP connection 156
 - name/provider of a connection . . . 154
 - number assignment 169, 170
 - opening web page 149
 - phone status 189
 - preferred DNS server 152
 - remote access 152
 - selecting IP address type 151
 - setting phone 150
 - specifying dialing plans 172
 - status of a VoIP connection 155
 - structure of the web pages 147
 - subnet mask 151
- Web interface, see Web configurator
- Web page (Web configurator)
 - opening 149
 - structure 147
- Web server see Web configurator
- Wide Area Network 236
- Withholding
 - phone number display 60
- Withholding number display 60
- Withholding phone number
 - display 60
- Working area (Web configurator) . . . 148
- Writing, editing text 202

Mounting the charging cradle to the wall

Mounting the charging cradle to the wall

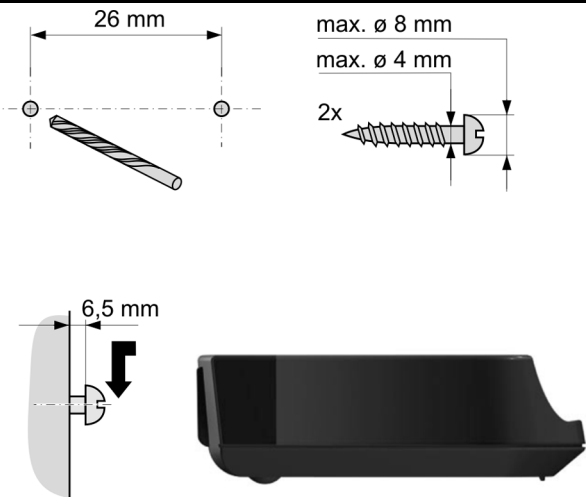

Mounting the base station to the wall

