

Introduction

Purpose of this Manual

This manual provides instruction for installing Mat Reader Assembly Kit C00016-XXX.

The Mat Reader allows customers to automatically authorize sales using a hand-held transponder tag.

Important Notice

This equipment has been tested and found to comply with the limits for a Class A digital device pursuant to Part 15 of the Federal Communications Commission (FCC) Rules. These limits are designed to provide reasonable protection against harmful interference when the equipment is operated in a commercial environment. This equipment generates, uses and can radiate radio frequency energy, and if not installed and used in accordance with the instruction manual, may cause harmful interference to radio communications. Operation of this equipment in a residential area is likely to cause harmful interference in which case the user will be required to correct the interference at his own expense. Changes or modifications not expressly approved by the manufacturer could void the user's authority to operate this equipment.

The long term characteristics or the possible physiological effects of radio frequency electromagnetic fields have not been investigated by Underwriters' Laboratories, Inc. (UL®).

Required Reading

Before installing the equipment, the installer must read, understand, and follow:

- this manual
- NFPA 70, The National Electrical Code (orderable at www.nfpa.org)
- applicable federal, state and local codes and regulations

Failure to do so may adversely effect the safe use and operation of the equipment.

Important Safety Information

This section introduces the hazards and safety precautions associated with installing, inspecting, maintaining or servicing this product. Before performing any task on this product, read this safety information and the applicable sections in this manual, where additional hazards and safety precautions for your task will be found. Electrical shock could occur and cause death or serious injury if these safe service procedures are not followed.

Preliminary Precautions

Read, understand and follow this manual and any other labels or related materials supplied with this equipment.

Follow the Regulations

There is applicable information in: NFPA 70: *National Electrical Code (NEC)*; OSHA regulations; and federal, state, and local codes which must be followed. Failure to install, maintain or service this equipment in accordance with these codes, regulations and standards may lead to legal citations with penalties or affect the safe use and operation of the equipment.

Safety Symbols and Warning Words

Alert Symbol



This safety alert symbol is used in this manual and on warning labels to alert you to a precaution which must be followed to prevent potential personal safety hazards. Obey safety directives that follow this symbol to avoid possible injury or death.

Signal Words

These signal words used in this manual and on warning labels tell you the seriousness of particular safety hazards. The precautions that follow must be followed to prevent death, injury or damage to the equipment.

DANGER

This signal word is used to alert you to a hazard or unsafe practice which **will** result in **death or serious injury**.

WARNING

This alerts you to a hazard or unsafe practice that **could** result in **death or serious injury**.

CAUTION

This signal word designates a hazard or unsafe practice which **may** result in **minor injury**.

CAUTION

When used by itself, CAUTION designates a hazard or unsafe practice which may result in **property or equipment damage**.

Proper Grounding is Required

Proper grounding is required for safe operation. See installation manual and applicable NEC, NFPA and local electrical codes for requirements.

Avoid Pinched Wires

Pinched or cut wires (cables) may damage components. Exposed wires could create sparks and electrical shorts when applying power.

Other Useful Safety Information

Replacement Parts

Use only genuine Gilbarco replacement parts. Using parts other than genuine Gilbarco replacement parts could create a safety hazard, violate national, state and local regulations or void warranty.

Reference Information

Related Documents

Installer must obtain, read and understand all site preparation documentation provided by the point of sale company authorizing the installation **before** attempting to install this equipment.

In addition, the installer must be familiar with the information in the following documents:

Document Number	Title	GOLD SM Library
MDE-3110	PC-Based G-SITE [®] System Installation Manual	G-SITE
MDE-3111	PC-Based G-SITE System Start-Up and Service Manual	<ul style="list-style-type: none"> • G-SITE • Service Manual
MDE-3620	Gilbarco [®] POS Console Site Preparation Manual	Site Prep
MDE-3982	Advanced Console Application KS000-XXXPC	G-SITE

Required Tools

The following equipment is needed to install all Mat Reader kits:

- drill motor and bits
- needle nose pliers
- screwdriver, Phillips[®] head
- Zircon[®] stud/bracket finder

Coaxial Cable and SMA Connector Handling Requirements

Coaxial antenna cables are more flexible and have a smaller diameter than more familiar coaxial cable, such as that used for cable television. However, all coaxial cables share this characteristic: turns or bends in coaxial cables must be gradual loops, no sharper than a 1-inch radius or 2-inch diameter (2.54 centimeter radius or 5 centimeter diameter).

CAUTION

Too severe a turn or bend in the cable will break the center (solid) fiber. This can result in an intermittent signal. It may also result in what appears to be proper performance at installation that is followed by premature failure and field service. In addition, a damaged cable will cause a situation where the transmitter printed circuit board (PCB) is powered without load, and damage the PCB.

An SMA connector is a type of connector that uses a threaded mount and connects one optical fiber. Due to its small size, use care when connecting the coaxial cable to as to not damage the SMA connector on the Interface Box or the coaxial cable.

Parts Lists

C00016-006 Kit - Low Frequency

C00016-006 Kits contain the following parts:

Description	Part Number	Quantity
box, interface assembly	M01814A001	1
tape, neoprene foam	M01870B001	2
channel, plastic filler	M01871B001	1
cable, mat reader drive	M01872A001	1
ferrite half	Q11433-110	2
ferrite, snap-on	Q11433-107	1
tape, acrylic foam	K85492-72	1
power supply	M01878B001	1
jack, jump	Q11011-01	1
cable, data, CAT-5	Q13482-06	1
clamp, cable, stick on, small	Q13459-01	3
decal, UL/FCC	M01868A001	1
document, installation	MDE-4017	1
screw, thread forming, 8-32x3/8"	K85736-06	2

C00016-008 Kit - High Frequency

C00016-008 Kits contain the following parts:

Description	Part Number	Quantity
box, interface assembly	M01814A002	1
tape, neoprene foam	M01870B002	1
channel, plastic filler	M01871B002	1
cable, mat reader drive	M01872A001	1
transient suppressor, magnetically coupled	Q11433-110	2
ferrite, snap-on	Q11433-106	1
ferrite, snap-on	Q11433-107	1
tape, acrylic foam	K85492-72	1
power supply	M01878B001	1
jack, jump	Q11011-01	10
cable, data, CAT-5	Q13482-06	1
clamp, cable, stick on, small	Q13459-01	3
decal, UL/FCC	M01868A002	1
document, installation	MDE-4017	1
screw, thread forming, 8-32x3/8"	K85736-06	2

C00016-010 Kit - Low Frequency Mini Mat

C00016-010 Kits contain the following parts:

Description	Part Number	Quantity
box, interface assembly	M01814A001	1
tape, neoprene foam	M02498B001	1
cable, mat reader drive	M01872A002	1
ferrite, snap-on	Q11433-107	1
power supply	M01878B001	1
jack, jump	Q11011-01	1
cable, data, CAT-5	Q13482-06	1
clamp, cable, stick on, small	Q13459-01	3
decal, UL/FCC/IC® (Industry Canada), see Note	M01868A003	1
document, installation	MDE-4017	1
screw, thread forming, 8-32x3/8"	K85736-06	2

Note: "IC:" before the certification/registration number only signifies that the Industry Canada technical specifications were met.

Mat Reader

The following component is also required in addition to the C00016-XXX kit.

Description	Part Number (Note)	Applicable Kit(s)	Quantity
mat reader, small	MR01002GXXX	C00016-006 C00016-008	1
mat reader, mini	MR01003GXXX	C00016-010	1

Note: XXX is the graphic-specific identifier.

Interconnect/Block Diagrams

Mat Reader Interconnect/Block Diagram M01873 (Sheet 1)

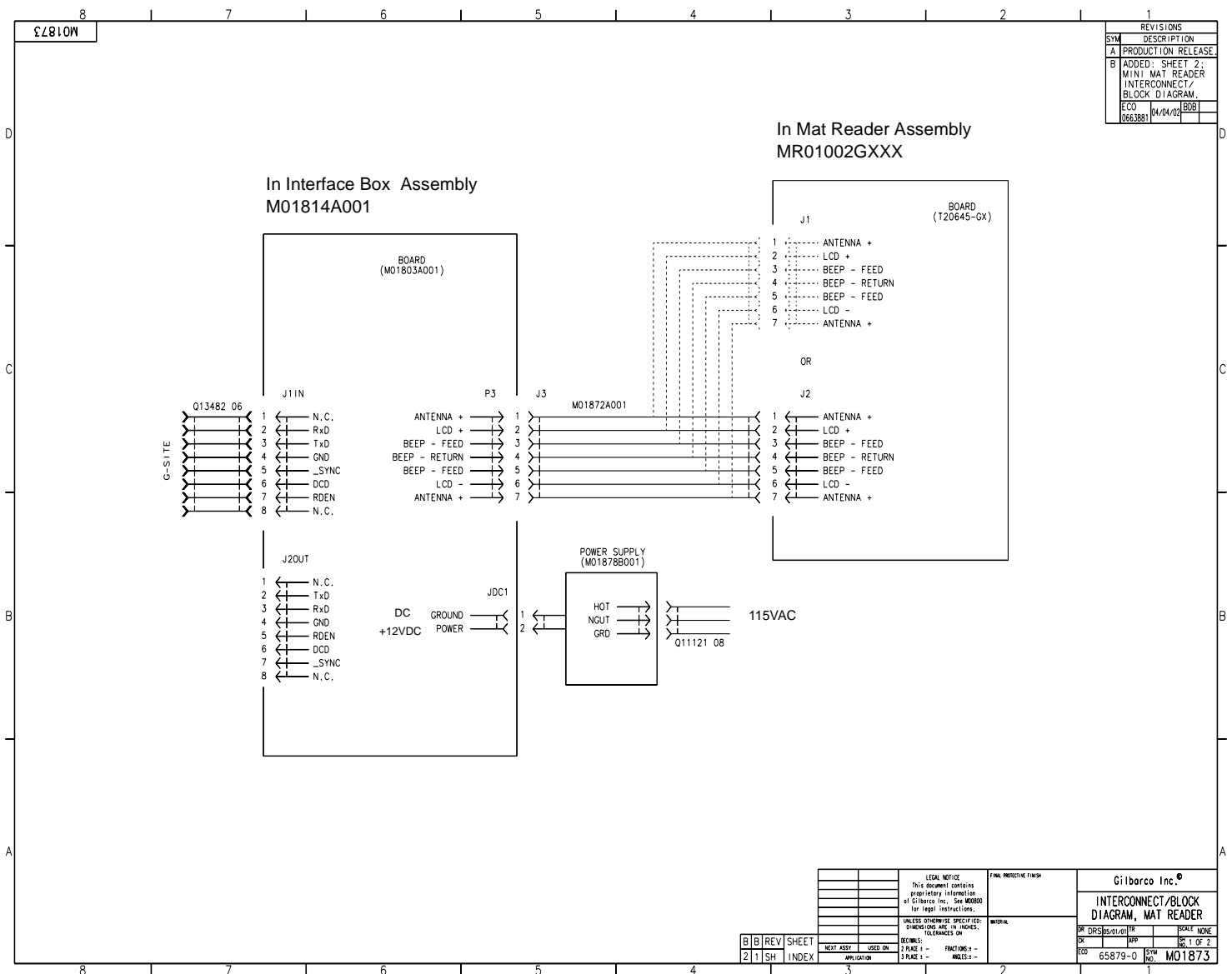

Mat Reader Interconnect/Block Diagram M01873 (Sheet 2)

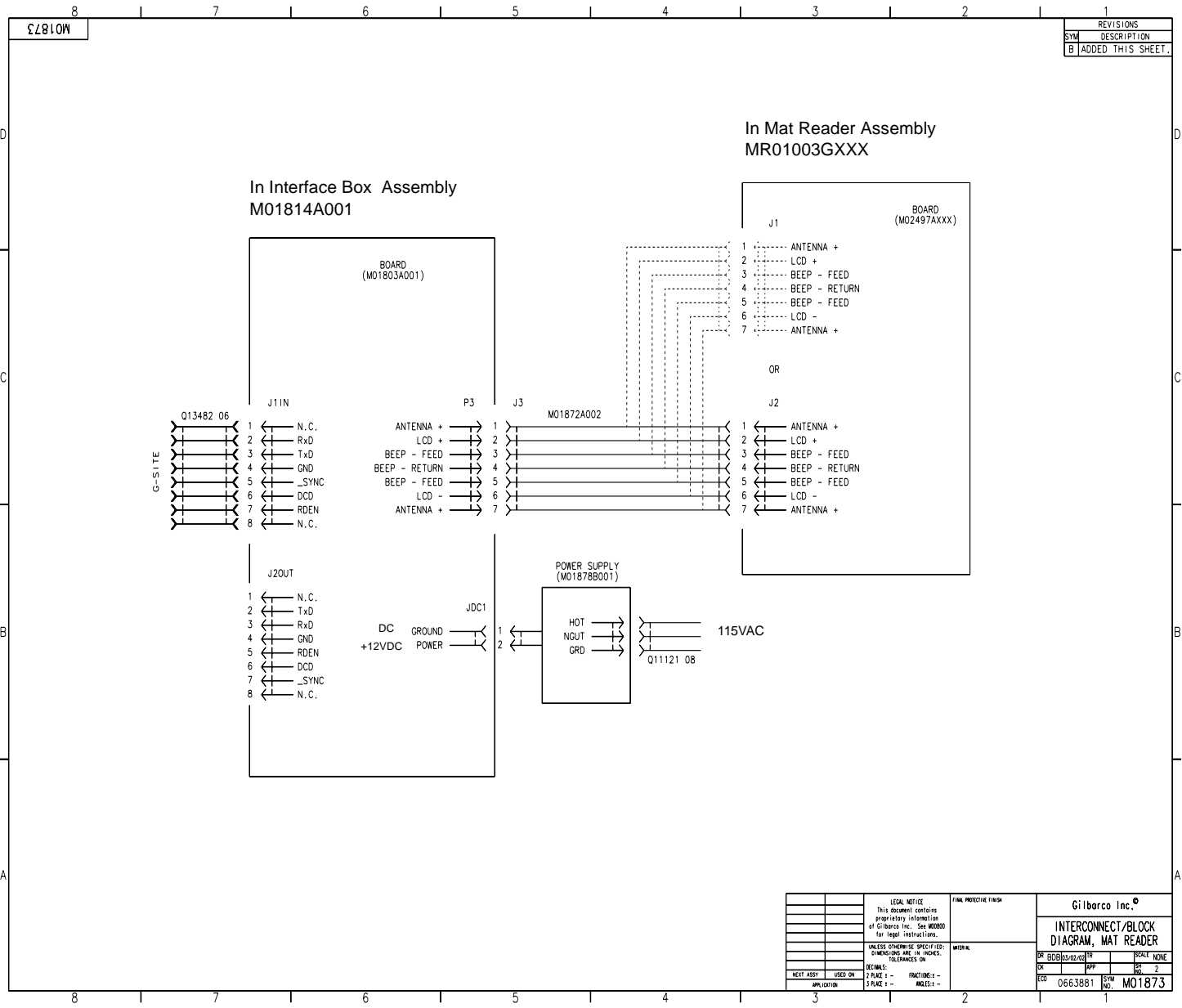

LEGAL NOTICE This document contains proprietary information of Gilbarco Inc. See W00000 for legal instructions.	FINAL PROTECTIVE FINISH	Gilbarco Inc.®	
UNLESS OTHERWISE SPECIFIED: DIMENSIONS ARE IN INCHES. TOLERANCES ON:	MATERIAL	INTERCONNECT/BLOCK DIAGRAM, MAT READER	
DECIMALS: ±		REV: 06/03/02/02	SCALE: NONE
FRACTIONS: ±		DATE: 06/03/02	SHEET: 2
ANGLES: ±		APP: 0663881	SYM No: M01873
NEXT ASSY USED ON APPLICATION	2 PLACE ±		
	ANGLES ±		

Mat Reader Interconnect/Block Diagram M02110

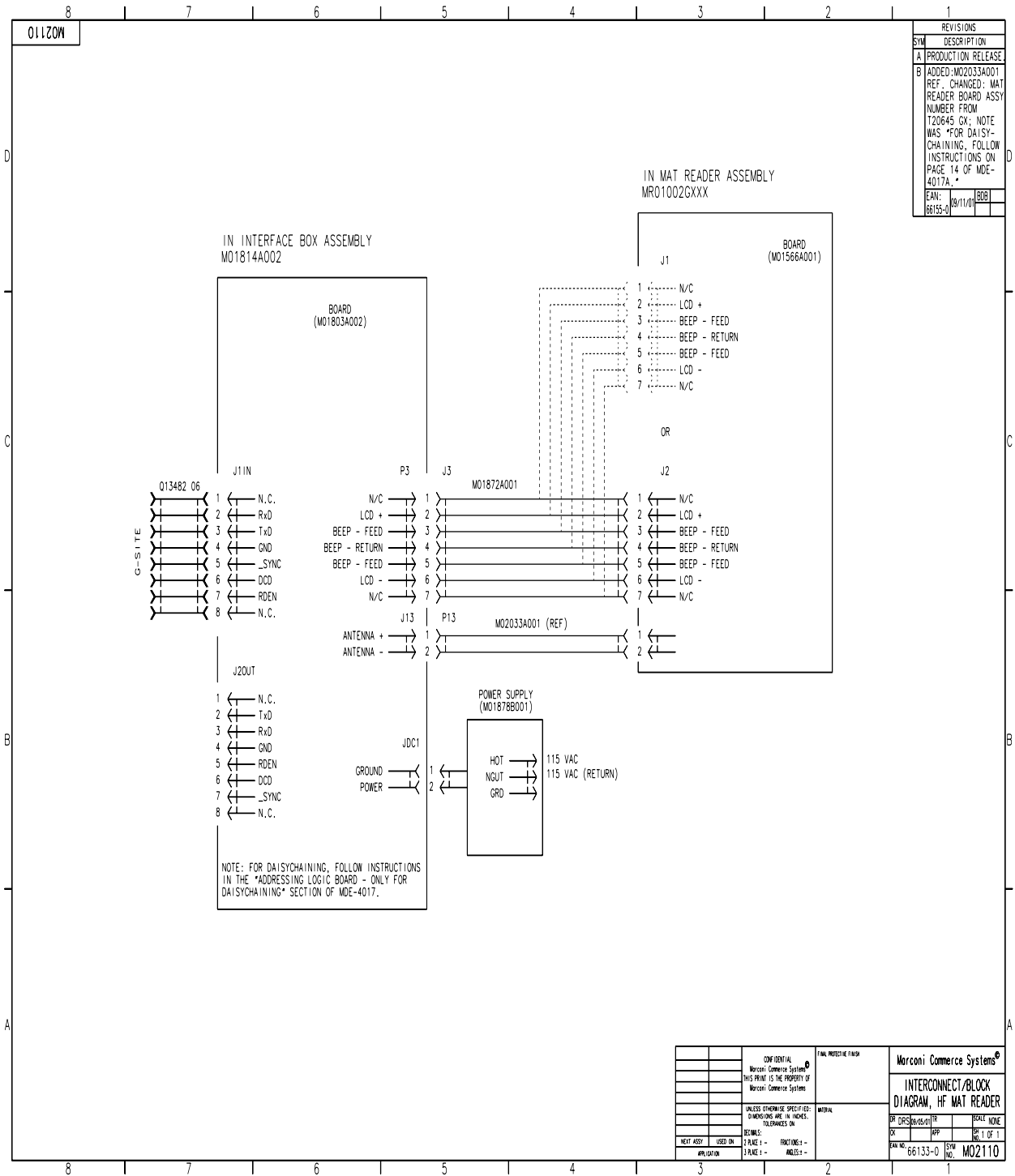

Installation

Note: All installation work is to be accomplished between the hours specified by the point of sale company authorizing the installation.

Install the Mat Reader assembly according to the following instructions.

Collect and arrange for safety and convenience all tools and equipment.

Positioning the Mat Reader

Gilbarco recommends the following concerning the placement of a Mat Reader on the counter top relative the following devices:

- any cathode ray tube (CRT), such as the point-of-sale (POS) monitor
- any device with a card reader, such as a personal identification number (PIN) pad
- the Mat Reader Interface Box
- countertop material

In Relation to a CRT

In general, a Mat Reader should be positioned as far away as is conveniently possible from any CRT device to avoid interference from the CRT and to ensure optimum performance of the Mat Reader. The interference from a CRT can vary greatly from unit to unit and model to model. Also, the presence of nearby masses of metal can affect the influence of a CRT.

There is no universal minimum separation that guarantees trouble-free operation. If the distance between the Mat Reader and CRT cannot be increased, changing the relative orientation of these items may yield better operation of the Mat Reader. However, increasing the distance will always give the most dramatic improvement in Mat Reader performance.

In Relation to a Card Reader

In general, any device with a card reader should be positioned as far as is conveniently possible from a Mat Reader. Since card readers are unshielded, loosely filtered devices, they are potential victims of any magnetic interference. The Mat Reader generates a magnetic field as part of its normal operation that can be such a source of magnetic interference to a card reader.

If a known, good card reader begins to display poor read performance after the addition of a Mat Reader to the POS system, significant improvements to card reader performance may be realized by simply increasing its separation from the Mat Reader by as little as a few inches. As a general rule, placing a card reader beside a Mat Reader has far less effect on the card reader than actually using the card reader while it is physically on, or held over, the Mat Reader. A counter top configuration where the card reader could be used in this manner should be avoided.

In Relation to the Interface Box

For optimum Mat Reader performance, the Interface Box should be positioned as close to the Mat Reader as is conveniently possible. If necessary, the CAT-5 cable, Q13482-06, may be swapped out for a longer version in order to properly place the Interface Box and still reach the POS connection. The dash number, such as -06, indicates 6 feet (1.8 meters) long.

In Relation to the Countertop Material

If the countertop material is stainless steel, Formica® covered steel, or some other metallic material, less than desired performance will be experienced. In the preferred setup, the countertop should be Corian®, plastic, wood, or some other non-metallic and/or non-ferrous material.

Preliminary
05/16/02

Setting Baud Rate

- 1 Remove Mat Reader Interface Box cover to access the logic board.

Figure: M01814A001 Mat Reader Interface Box Cover

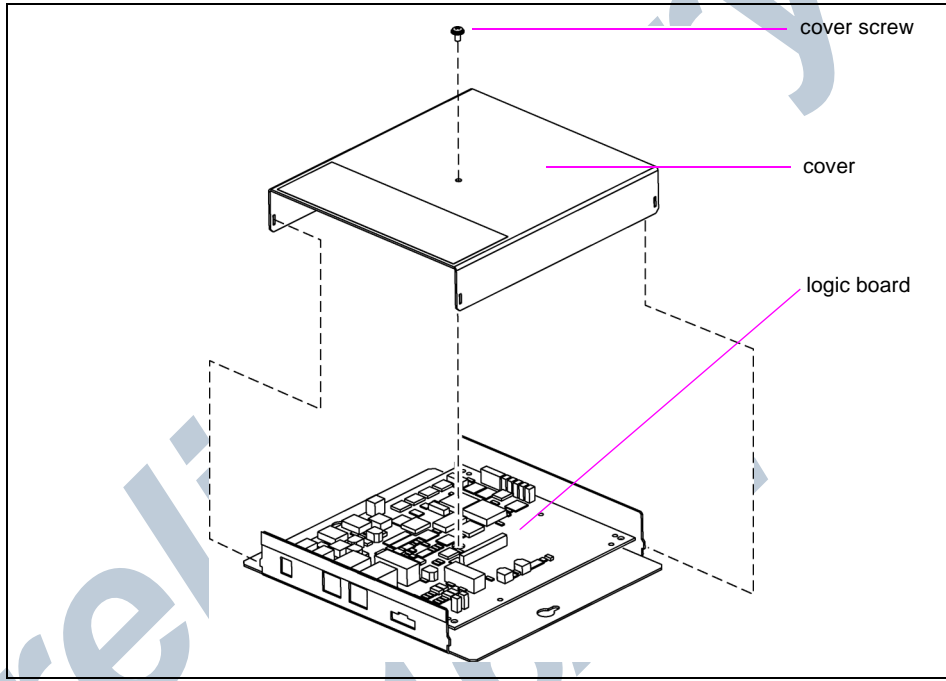
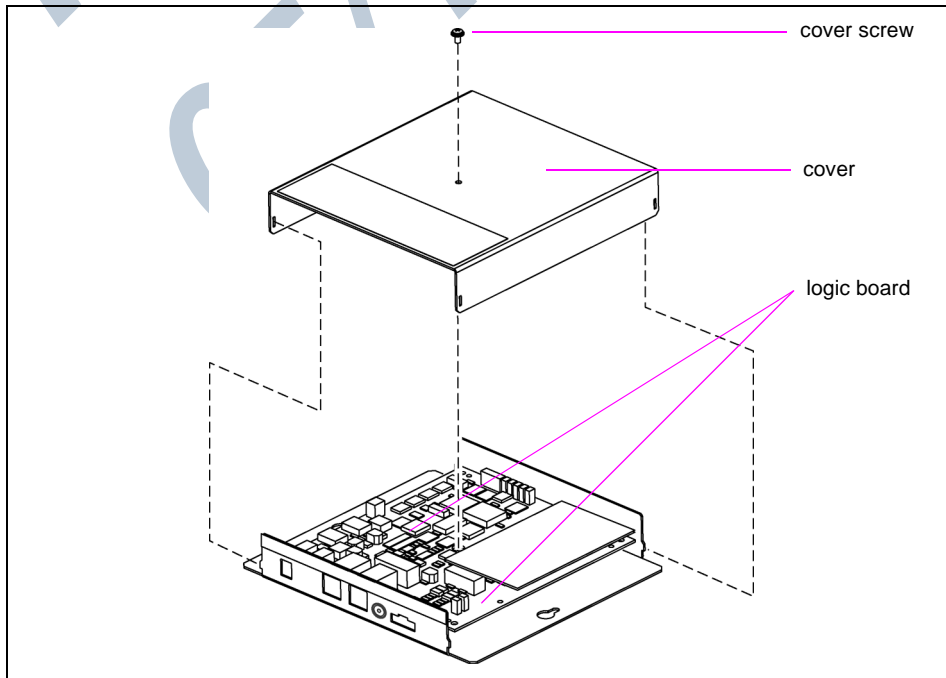

Figure: M01814A002 Mat Reader Interface Box Cover



2 Locate jump jacks on logic board for Mat Reader.

Figure: Jump Jacks for Baud Rate Setting - M01803A001

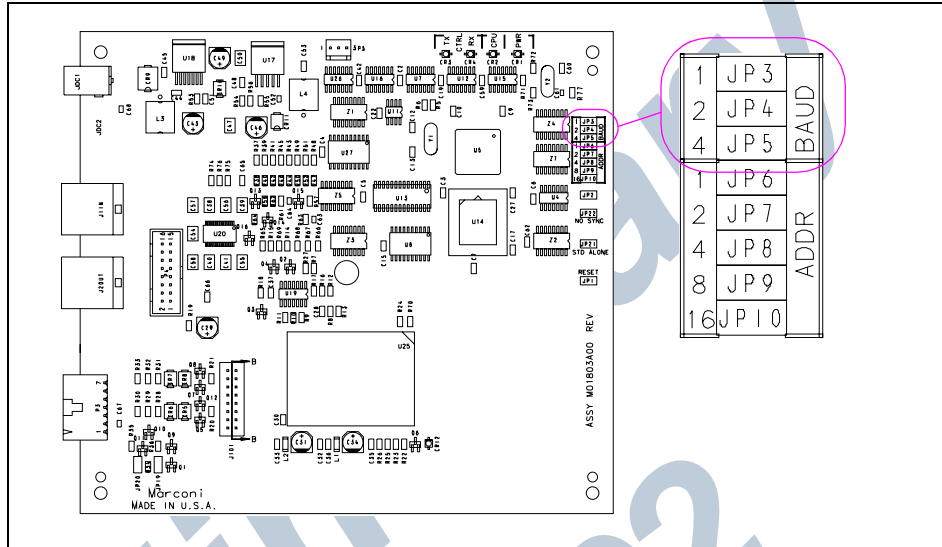
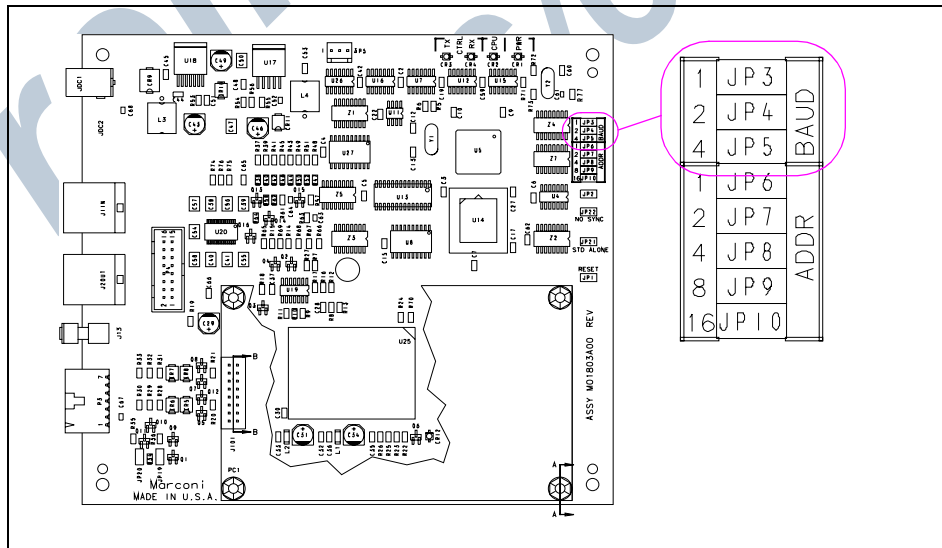

Figure: Jump Jacks for Baud Rate Setting - M01803A002



- Set the jump jacks as follows (see the appropriate figure: “Figure: Jump Jacks for Baud Rate Setting - M01803A001” on page 13 or “Figure: Jump Jacks for Baud Rate Setting - M01803A002” on page 13).

CAUTION



Electrostatic Discharge Damage

Printed circuit boards (PCBs) and integrated circuits (ICs) are sensitive to electrostatic discharge caused by static electricity. Electrostatic discharge damages electronic parts. Follow these guidelines when handling sensitive parts:

- Touch an unpainted metal surface to discharge any static electricity buildup.
- Use a wrist strap connected to a grounded metal frame or chassis.

Mat Reader Baud Rates

Baud Rate (Note)	BAUD 1	BAUD 2	BAUD 4
4800	OUT	OUT	OUT
2400	IN	OUT	OUT
1200	OUT	IN	OUT
300	IN	IN	OUT
38400	OUT	OUT	IN
19200	IN	OUT	IN
9600	OUT	IN	IN
4800	IN	IN	IN

Note: 4800 is the default value and the Mat Reader value.

- If not daisy chaining Mat Reader Interface Boxes, reinstall cover.
Note: Daisy chaining is connecting the output from one Interface Box to the input of another.

Addressing Logic Board - Only for Daisychaining

Address for Mat Reader must match address on previously installed Mat Reader. Follow these steps:

- 1 Access logic board for Mat Reader being installed.
- 2 Locate jump jacks on previously installed Mat Reader logic board M01803A001 or M01803A002 as appropriate.

Figure: M01803A001 Jump Jacks for Address Setting

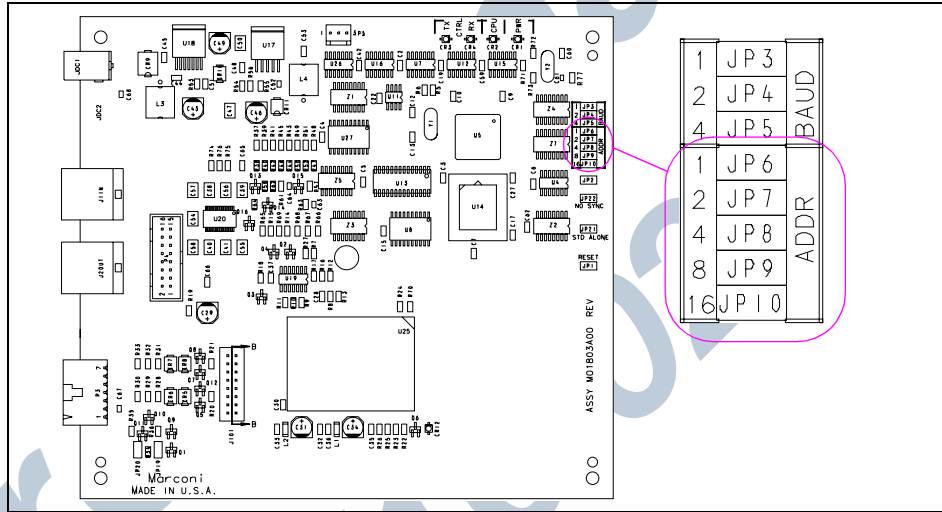
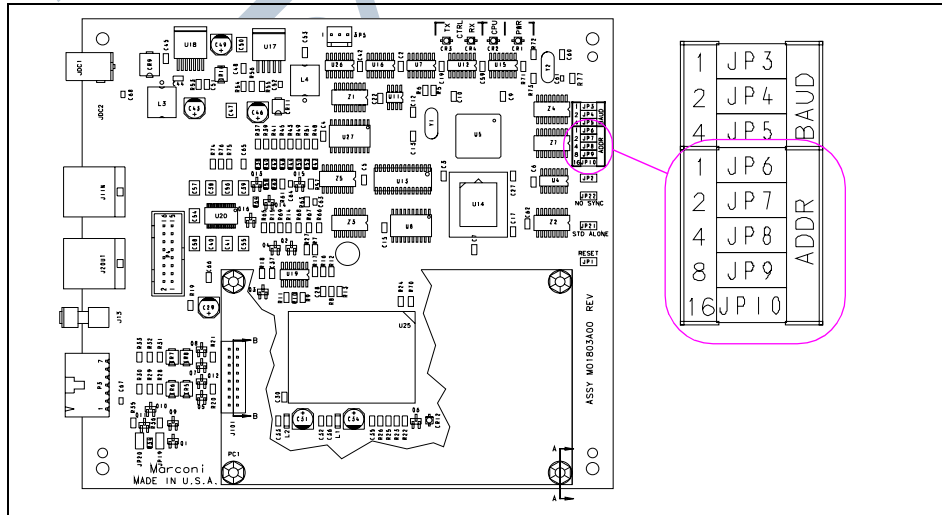

Figure: M01803A002 Jump Jacks for Address Setting



- 3 Note position of jump jacks on previously installed Mat Reader logic board, and set jump jacks on board for Mat Reader being installed to match address on logic board (see Caution that follows).

CAUTION



Electrostatic Discharge Damage

Printed circuit boards (PCBs) and integrated circuits (ICs) are sensitive to electrostatic discharge caused by static electricity. Electrostatic discharge damages electronic parts. Follow these guidelines when handling sensitive parts:

- Touch an unpainted metal surface to discharge any static electricity buildup.
- Use a wrist strap connected to a grounded metal frame or chassis.

Mat Reader Addresses

Address on Logic Board M01803A001/M01803A002	ADDR 1	ADDR 2	ADDR 4	ADDR 8	ADDR 16
0	OUT	OUT	OUT	OUT	OUT
1	IN	OUT	OUT	OUT	OUT
2	OUT	IN	OUT	OUT	OUT
3	IN	IN	OUT	OUT	OUT
4	OUT	OUT	IN	OUT	OUT
5	IN	OUT	IN	OUT	OUT
6	OUT	IN	IN	OUT	OUT
7	IN	IN	IN	OUT	OUT
8	OUT	OUT	OUT	IN	OUT
9	IN	OUT	OUT	IN	OUT
10	OUT	IN	OUT	IN	OUT
11	IN	IN	OUT	IN	OUT
12	OUT	OUT	IN	IN	OUT
13	IN	OUT	IN	IN	OUT
14	OUT	IN	IN	IN	OUT
15	IN	IN	IN	IN	OUT
16	OUT	OUT	OUT	OUT	IN
17	IN	OUT	OUT	OUT	IN
18	OUT	IN	OUT	OUT	IN
19	IN	IN	OUT	OUT	IN
20	OUT	OUT	IN	OUT	IN
21	IN	OUT	IN	OUT	IN
22	OUT	IN	IN	OUT	IN
23	IN	IN	IN	OUT	IN
24	OUT	OUT	OUT	IN	IN
25	IN	OUT	OUT	IN	IN
26	OUT	IN	OUT	IN	IN
27	IN	IN	OUT	IN	IN
28	OUT	OUT	IN	IN	IN
29	IN	OUT	IN	IN	IN
30	OUT	IN	IN	IN	IN
31	IN	IN	IN	IN	IN

4 Reinstall cover.

Mounting Mat Reader Interface Box

- 1 Determine the location for the installation of indoor equipment. The Interface Box may be mounted under the counter top (upside down) or vertically on one of the supporting walls of the counter top.
Note: Refer to site prep document provided by point of sale company and keep in mind overall 5-foot (1.5 meter) length of cable to connect Mat Reader Interface Box to Mat Reader. Also refer to “In Relation to the Interface Box” on page 11.
- 2 Use a Zircon stud/bracket finder to ensure no electrical conduits or pipes are located inside of wall where the Mat Reader Interface Box is to be mounted. Also, ensure the Mat Reader Interface Box is to be located where studs or wall (concrete/brick/drywall) molls can be used for mounting.
- 3 Mark and drill holes. Insert wall molls if required.

CAUTION

Do not use the Mat Reader Interface Box as a drill guide. It may be used as a template to mark the holes to be drilled.

- 4 Use 8-32 thread-forming screws provided or other appropriate contractor-supplied mounting hardware to secure the Mat Reader Interface Box to the wall or under counter top.
Note: 3/8-inch deep pilot holes (approximately 1/8-inch diameter) will be required if the screws provided are used.

Figure: Mat Reader Interface Box Mounting Holes

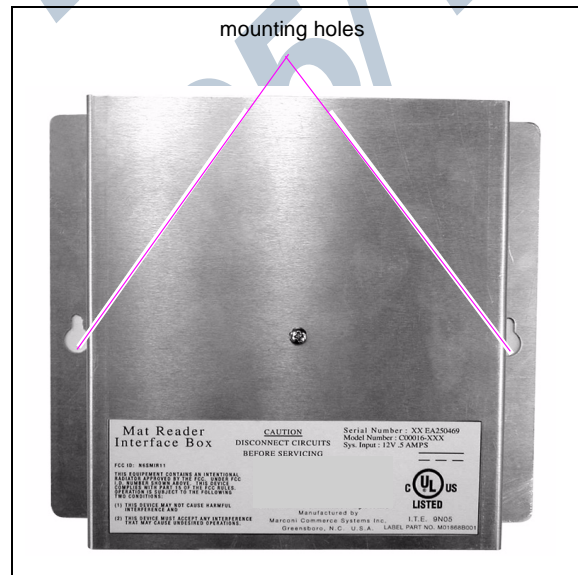

Connecting Data Cables to Mat Reader Interface Box

Run both power and data cables to port end of Mat Reader Interface Box (see “[Figure: Mat Reader Interface Box Mounting Holes](#)” on page 17) as follows:

- 1 Connect the P3 end of the ribbon cable (M01872A001) to the interface port (P3).
- 2 Connect the J1 end of the CAT-5 cable (Q13482-06) to the J1IN port.
Note: The other end of the CAT-5 cable will be connected to the POS controller in the instructions for “[Connecting Data Cables from the Mat Reader Interface Box](#)” on page 19.
- 3 If daisy chaining Interface Boxes, connect a CAT-5 cable from the J1IN port on the other Interface Box to the J2OUT port on this Interface Box.
- 4 If the Interface Box has an antenna connection, connect one end of the coaxial cable to the antenna connection (“[Figure: Connecting to Mat Reader Interface Box M01803A002](#)” on page 18). See “[Coaxial Cable and SMA Connector Handling Requirements](#)” on page 4.

Figure: **Connecting to Mat Reader Interface Box M01803A001**

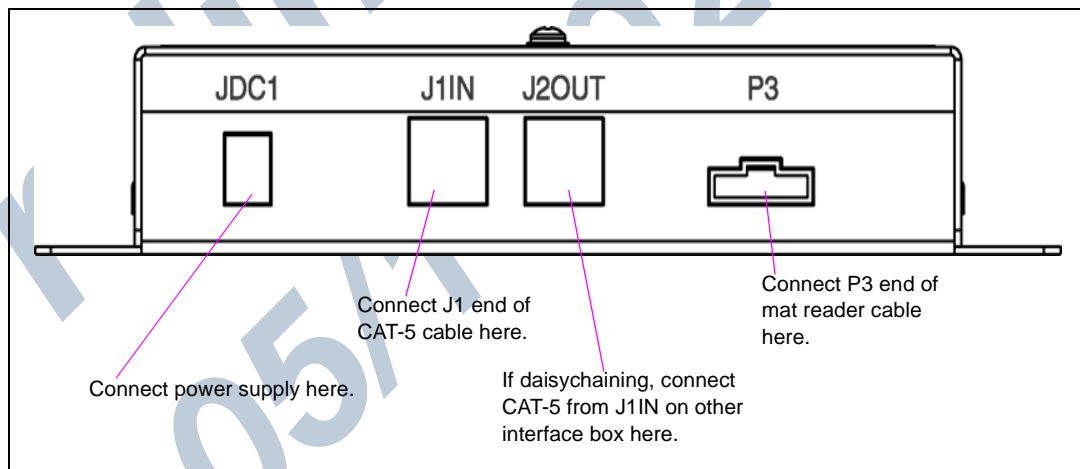
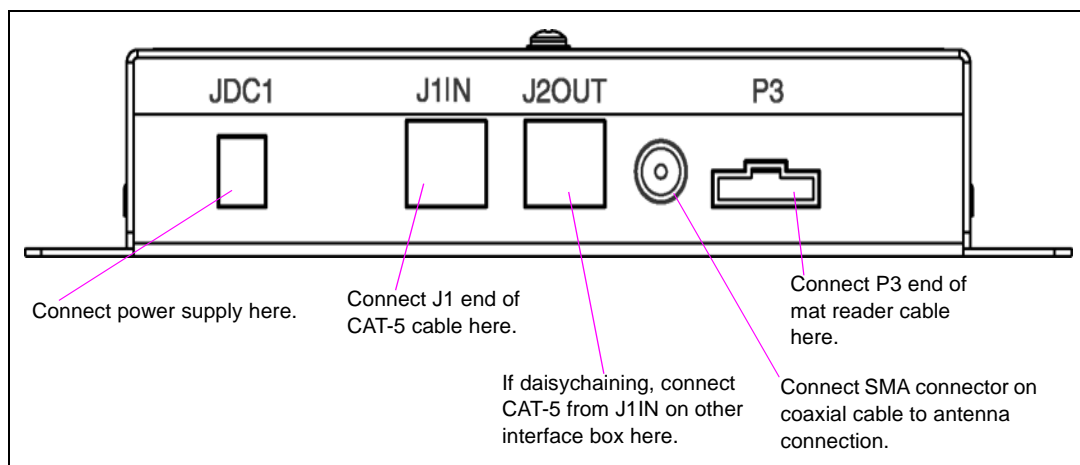

Figure: **Connecting to Mat Reader Interface Box M01803A002**



Connecting Data Cables from the Mat Reader Interface Box

Low Frequency Mat Reader

- 1 Position Mat Reader face down.

Figure: **Bottom Side of Mat Reader - Low Frequency**

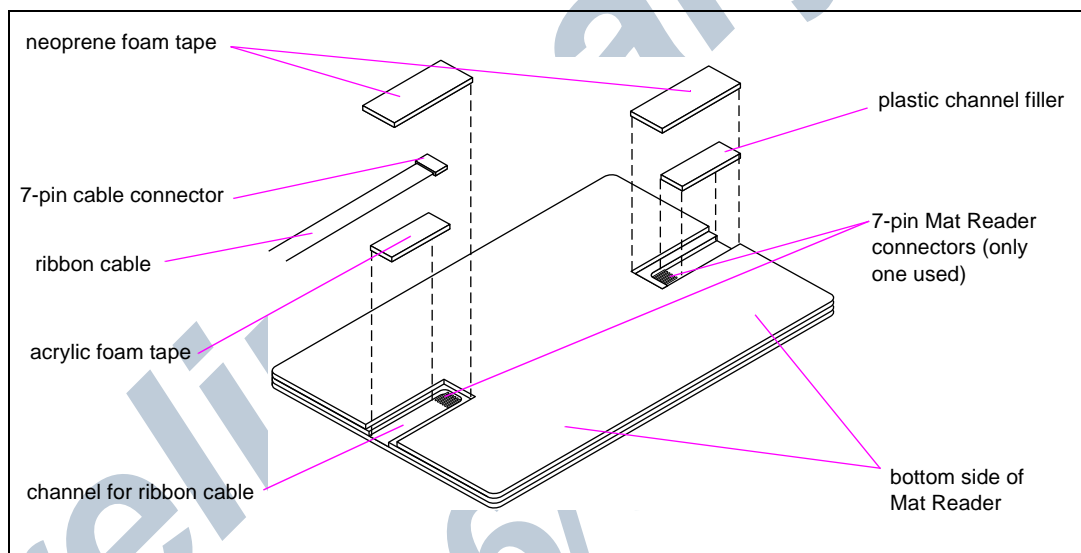

- 2 Select side for ribbon cable (M01872A001) connection based on counter top configuration requirements.

Note: The Mat Reader is designed to be placed on a counter top beside or adjacent to a cash register or point-of-sale (POS) terminal. If properly positioned, the Mat Reader ribbon cable will “disappear” underneath the existing POS equipment. The ribbon cable will penetrate the counter top via the same hole used by the POS power and data cables. Double-sided tape (not provided) may be used to secure the Mat Reader and/or the ribbon cable in position on the counter top.

- 3 Install strip of acrylic foam tape (K85492-72) in base of channel on side selected for ribbon cable.
- 4 Peel second release liner, exposing adhesive.
- 5 Carefully connect the P1/P2 end of the ribbon cable (M01872A001) to the back side of the Mat Reader.

Note: The cable can be plugged in from either side; the orientation does not matter. Be sure the cable will be flat and not twisted once the Mat Reader is face up.

Figure: **Connecting to Mat Reader - Low Frequency**

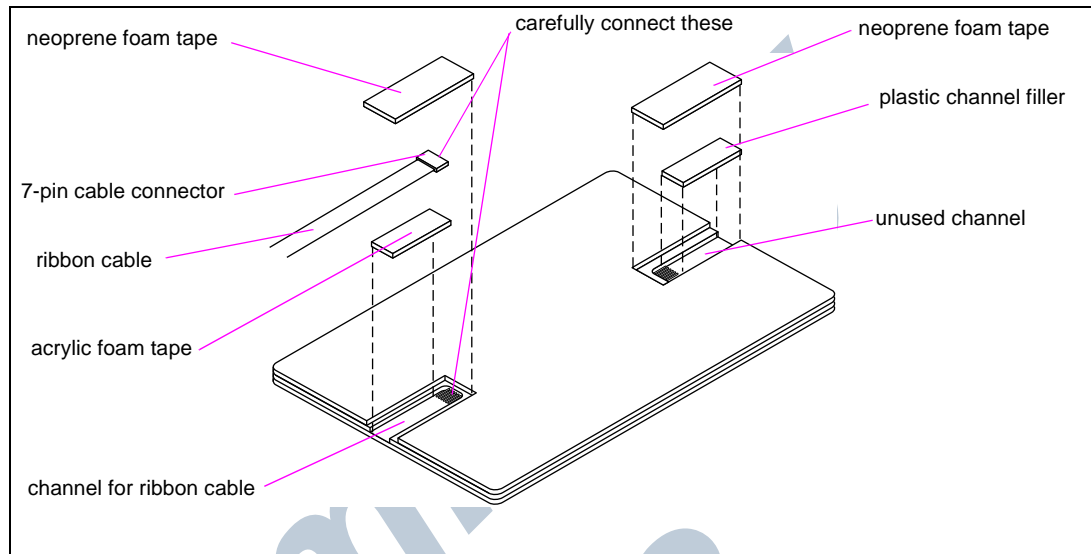

- 6 Peel release liner and install neoprene foam tape (M01870B001) over ribbon cable and sides of channel. Foam tape should fit snugly into cutout of surrounding foam tape backer.
- 7 On unused cable channel, install plastic filler channel (M01871B001).
- 8 Install remaining neoprene foam tape (M01870B001) over filler channel. Foam tape should fit snugly into cutout of surrounding foam tape backer.
- 9 Gently turn the Mat Reader to the face-up position.

Figure: **Mat Reader - Face Up**



- 10 Connect the loose end of the CAT-5 cable to the POS system.
Note: For a G-SITE system, the exact G-SITE system port depends on the G-SITE system configuration. Refer to MDE-3110 PC-Based G-SITE System Installation Manual.

Low Frequency Mini Mat Reader

- 1 Position Mat Reader face down.

Figure: **Bottom Side of Mini Mat Reader - Low Frequency**

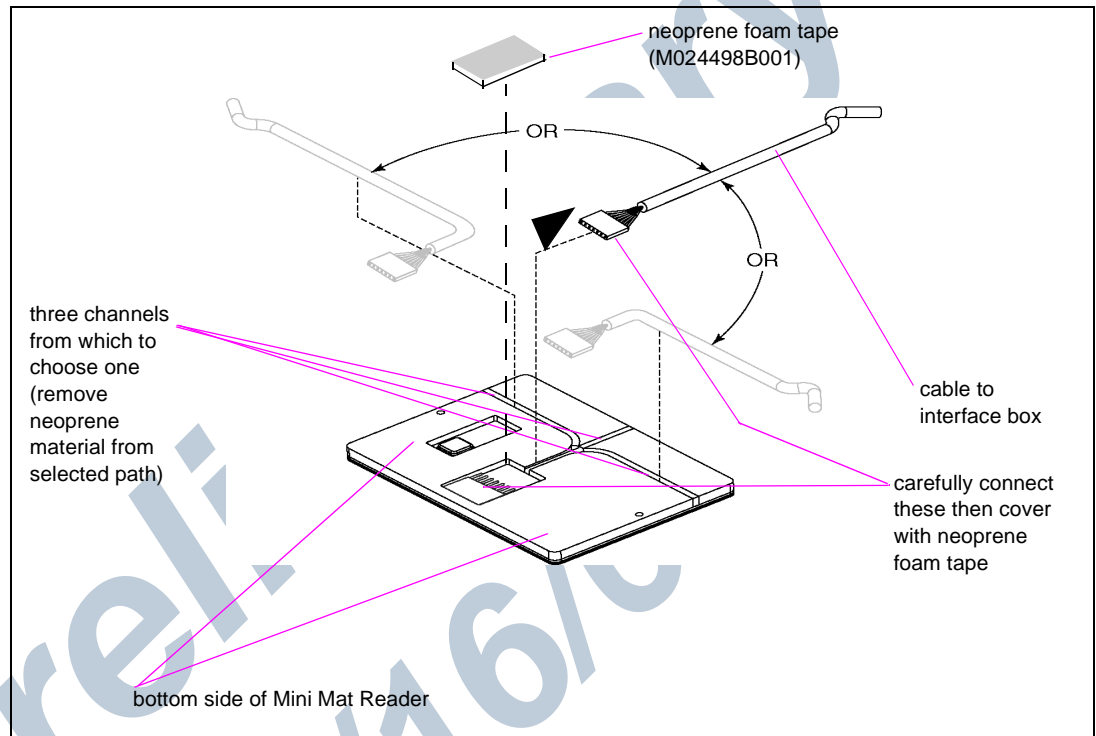

- 2 Select side for CAT-5 cable (M01872A002) connection based on counter top configuration requirements.

Note: The Mat Reader is designed to be placed on a counter top beside or adjacent to a cash register or point-of-sale (POS) terminal. If properly positioned, the Mat Reader cable will “disappear” underneath the existing POS equipment. The cable will penetrate the counter top via the same hole used by the POS power and data cables. Double-sided tape (not provided) may be used to secure the Mat Reader and/or the cable in position on the counter top.

CAUTION

Perform the next step by hand! Use of tools (i.e. screwdriver tip or knife blade) could damage PCB beneath the layer of neoprene, which could render the system inoperable and void the warranty.

- 3 Using fingers, spread open the precut backing for the cable routing path selected in the previous step and lift out the neoprene material from that path. Each cable path has been precut approximately 90 percent through. Lifting out the selected channel will cause slight tearing of the neoprene material which is to be expected.

- Carefully connect the P1/P2 end of the cable (M01872A002) to the back side of the Mat Reader, and press the cable into the cable path channel created in step 3.
- Peel the backing from the neoprene foam tape (M02498B001) and place over the P1/P2 cable connection. Be sure to press tape down firmly so it contacts the PCB around the perimeter of the connector.

Figure: **Connecting to Mini Mat Reader - Low Frequency**

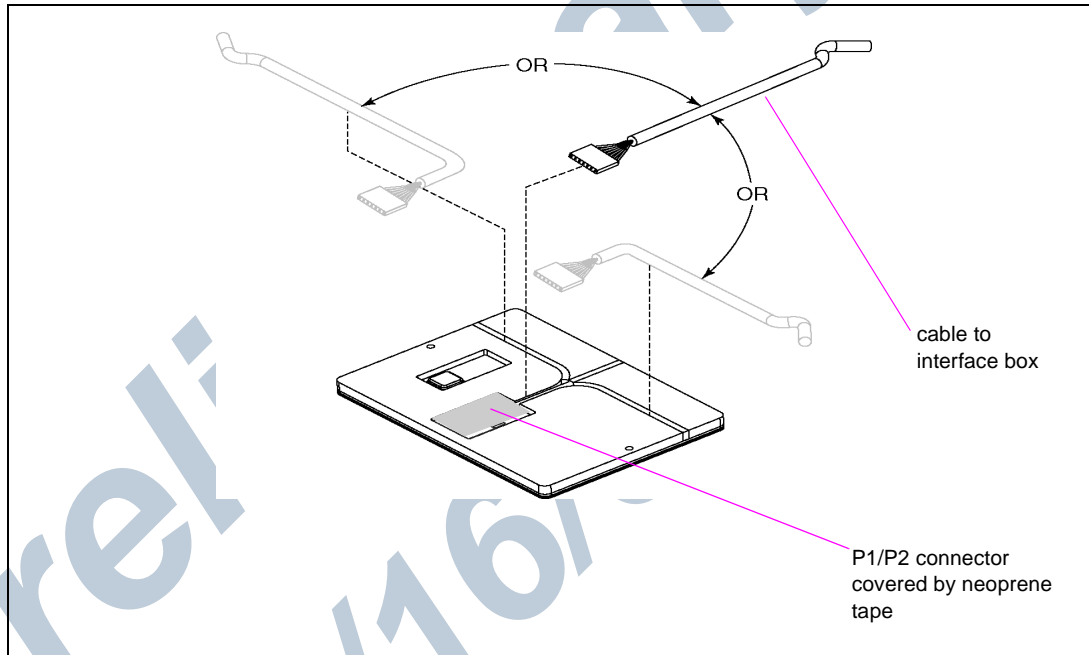

- Gently turn the Mat Reader to the face-up position.

Figure: **Mat Reader - Face Up**



- Connect the loose end of the CAT-5 cable to the POS system.
Note: For a G-SITE system, the exact G-SITE system port depends on the G-SITE system configuration. Refer to MDE-3110 PC-Based G-SITE System Installation Manual.

High Frequency Mat Reader

- 1 Position Mat Reader face down.

Figure: **Bottom Side of Mat Reader - High Frequency**

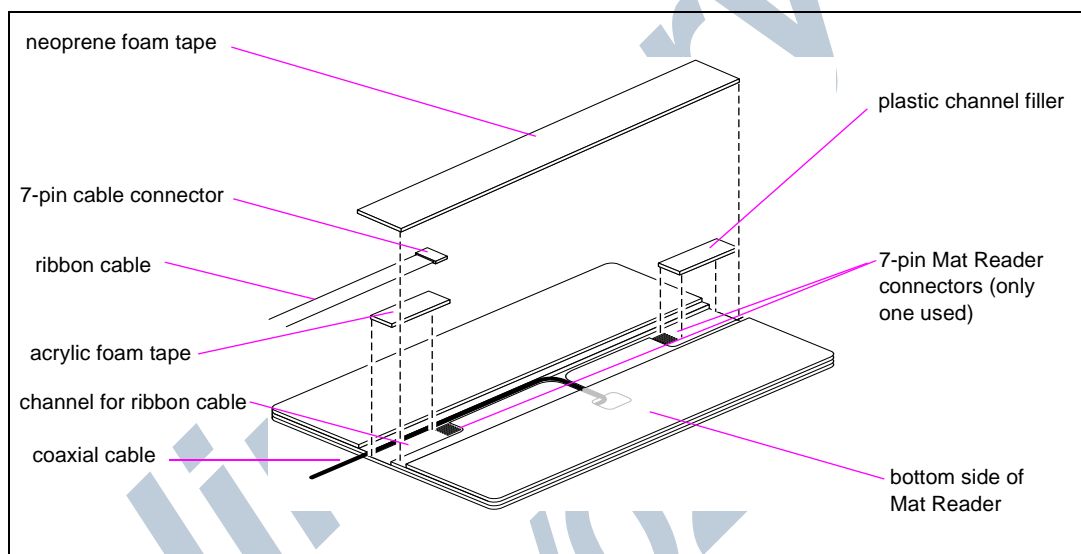

- 2 Select side for ribbon cable (M01872A001) connection based on counter top configuration requirements.

Note: The Mat Reader is designed to be placed on a counter top beside or adjacent to a cash register or point-of-sale (POS) terminal. If properly positioned, the Mat Reader ribbon cable will “disappear” underneath the existing POS equipment. The ribbon cable will penetrate the counter top via the same hole used by the POS power and data cables. Double-sided tape (not provided) may be used to secure the Mat Reader and/or the ribbon cable in position on the counter top.

- 3 Install strip of acrylic foam tape (K85492-72) in base of channel on side selected for ribbon cable.
- 4 Peel second release liner, exposing adhesive.
- 5 Carefully connect the P1/P2 end of the ribbon cable (M01872A001) to the back side of the Mat Reader.
Note: The cable can be plugged in from either side; the orientation does not matter. Be sure the cable will be flat and not twisted once the Mat Reader is face up.
- 6 Carefully connect the coaxial cable to the antenna connection on the Interface Box (M01803A002). Route the coaxial cable in the channel on the same side as the ribbon cable.

Figure: **Connecting to Mat Reader - High Frequency**

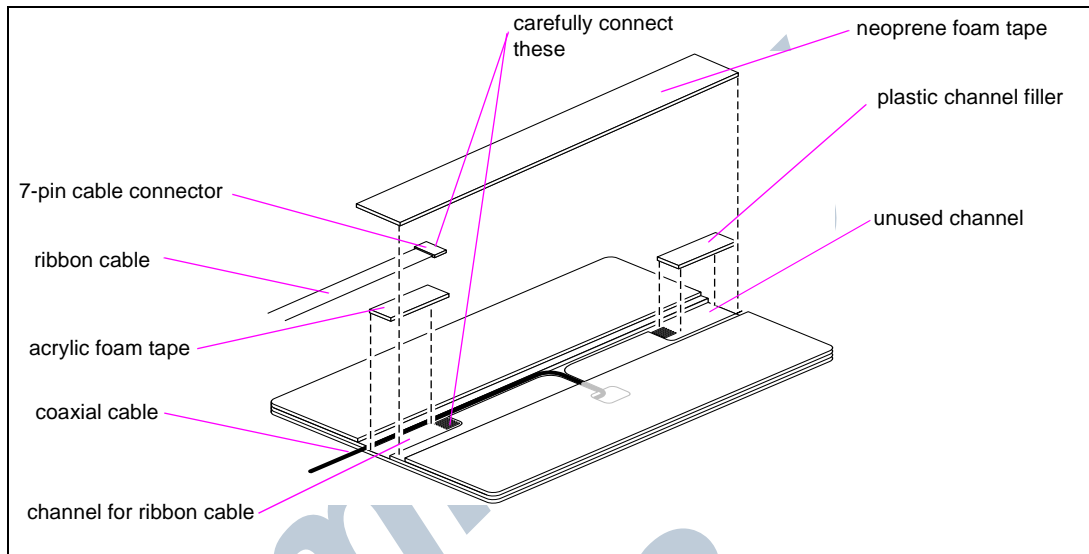

- 7 On unused cable channel, install plastic filler channel (M01871B002).
- 8 Install neoprene foam tape (M01870B002) over filler channel, ribbon cable, and coaxial cable. Foam tape should fit snugly into cutout of surrounding foam tape backer.
- 9 Gently turn the Mat Reader to the face-up position.

Figure: **Mat Reader - Face Up**

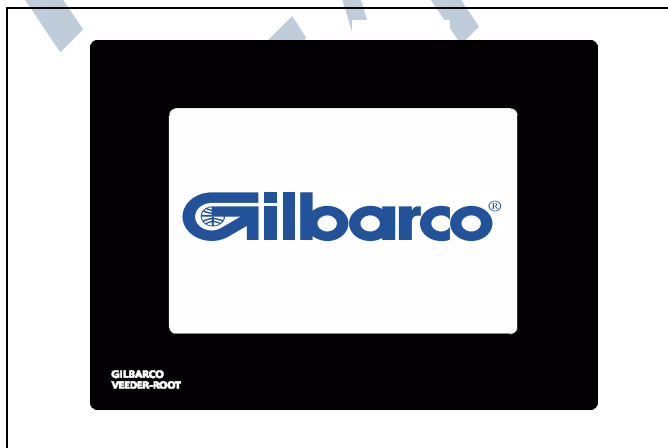

- 10 Connect the loose end of the CAT-5 cable to the POS system.
Note: For a G-SITE system, the exact G-SITE system port depends on the G-SITE system configuration. Refer to MDE-3110 PC-Based G-SITE System Installation Manual.

Connecting Power Supply

Figure: Power Supply (M01878B001)

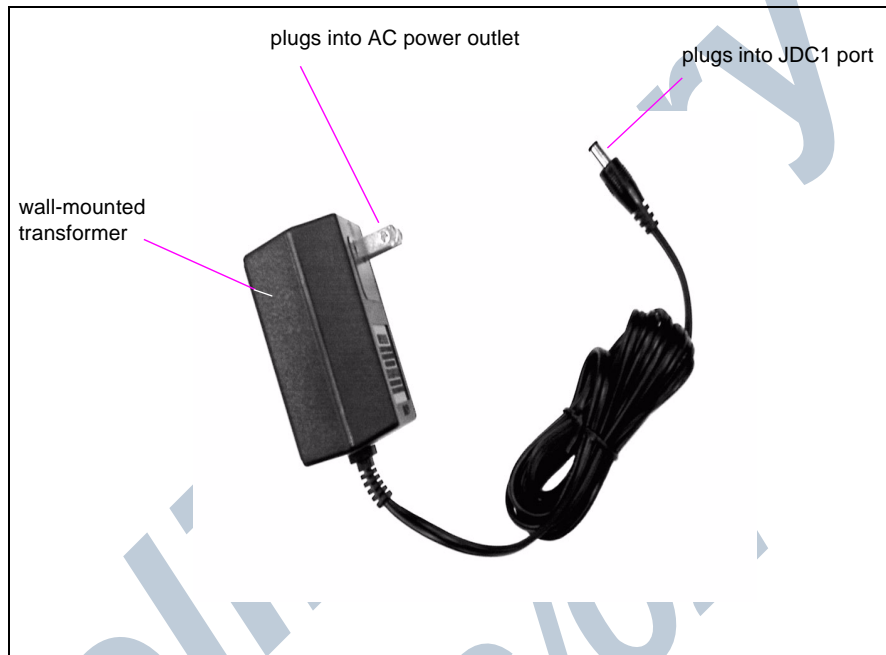

Low and High Frequency Mat Readers

Connect the power supply (M01878B001) provided with kit as shown.

- 1 Plug the wall-mounted transformer into the AC power outlet.
Note: If the POS is a G-SITE system, this AC power outlet must be on the same circuit as the G-SITE system.
- 2 Connect the plug end of the power supply cable to the JDC1 port on the Mat Reader Interface Box (see [“Figure: Connecting to Mat Reader Interface Box M01803A001” on page 18](#) or [“Figure: Connecting to Mat Reader Interface Box M01803A002” on page 18](#)).
- 3 Double loop the JDC1 end of the power supply cable through the ferrite bead (Q11433-107) with the bead in the open position, then snap the bead shut.

Figure: Power Supply (M01878B001) Cable with Ferrite

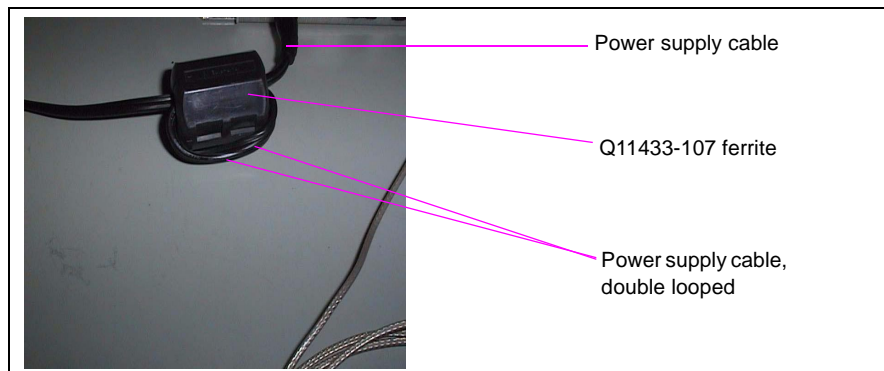

Mini Mat Readers

Connect the power supply (M01878B001) provided with kit as shown.

- 1 Plug the wall-mounted transformer into the AC power outlet.
Note: If the POS is a G-SITE system, this AC power outlet must be on the same circuit as the G-SITE system.
- 2 Connect the plug end of the power supply cable to the JDC1 port on the Mat Reader Interface Box (see [“Figure: Connecting to Mat Reader Interface Box M01803A001”](#) on page 18).

Note: The Q11433-107 ferrite will be installed in the first step under “Low Frequency Mini Mat Reader” on page 29 in the “Completing the Installation” section.

Preliminary
05/16/02

Completing the Installation

Low Frequency Mat Reader

Figure: Low Frequency Mat Reader Connections

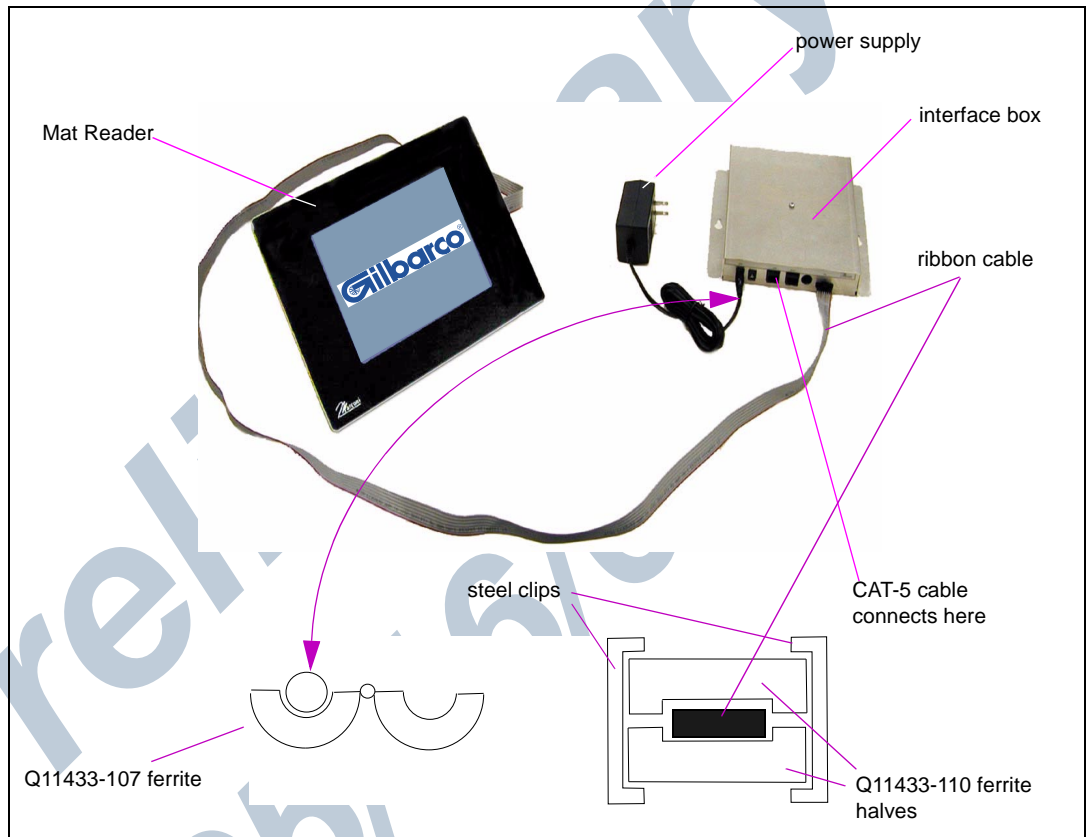

- 1 Install both ferrite halves Q11433-110 on ribbon cable, and secure with steep clips, as shown.

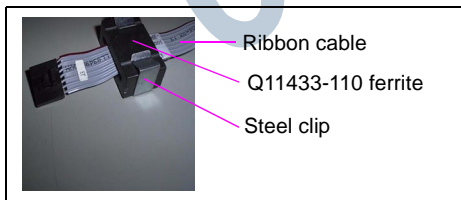

- 2 Be sure clip-on ferrite Q11433-107 is on interface box power supply cable (double loop).

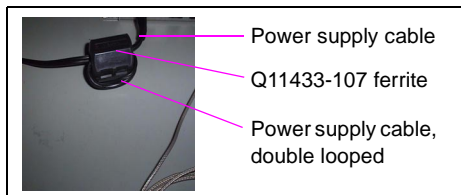

- 3 Dress all cables and secure with stick on cable clamps (Q13459-01).

- 4 Install M01868A001 UL/FCC decal, as appropriate, as shown in [“Figure: Mat Reader Interface Box Mounting Holes”](#) on page 17.
- 5 Clean up the work area.
- 6 Verify the keytag can be read by the mat reader within the specified range.

Figure: **Low Frequency Mat Reader Read Verification**

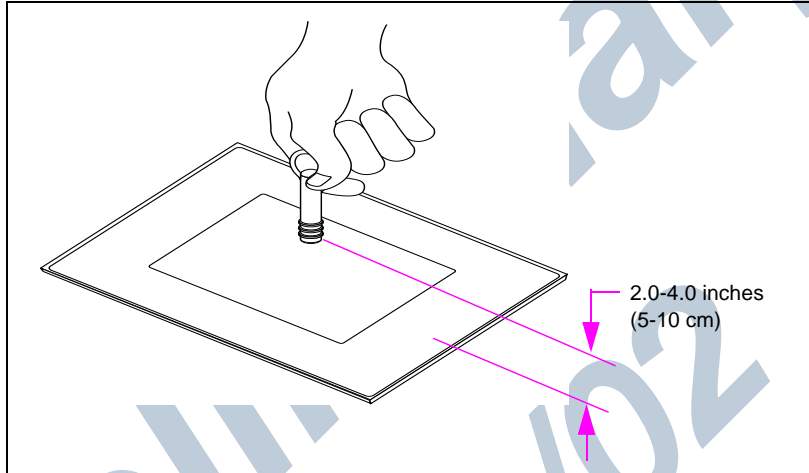

- 7 Go to [“Commissioning and Warranty Information”](#) on page 33.

Low Frequency Mini Mat Reader

Figure: Low Frequency Mini Mat Reader Connections

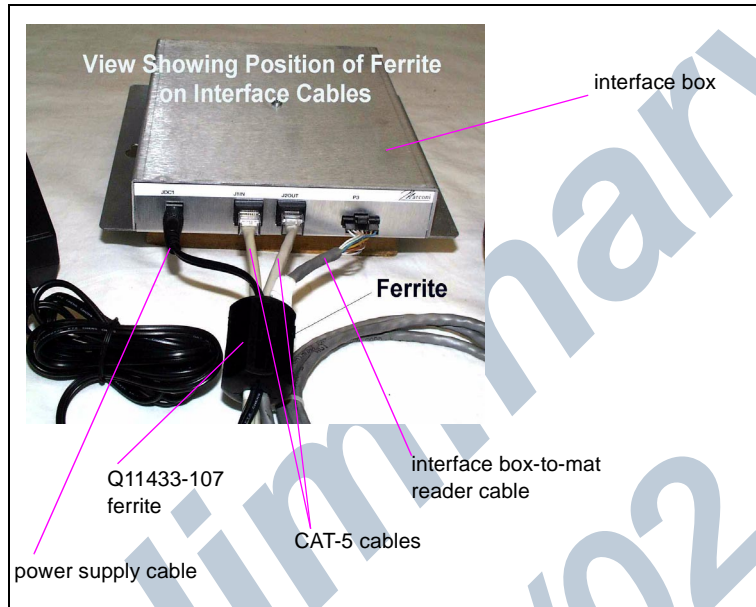

- 1 Route all cables near interface box end through Q11433-107 ferrite and snap ferrite closed.



- 2 Dress all cables and secure with stick on cable clamps (Q13459-01).
- 3 Install M01868A003 UL/FCC decal, as appropriate, as shown in [“Figure: Mat Reader Interface Box Mounting Holes”](#) on page 17.
- 4 Clean up the work area.
- 5 Verify the keytag can be read by the mat reader within the specified range (see [“Figure: Low Frequency Mini Mat Reader Read Verification”](#) on page 30).

Figure: Low Frequency Mini Mat Reader Read Verification

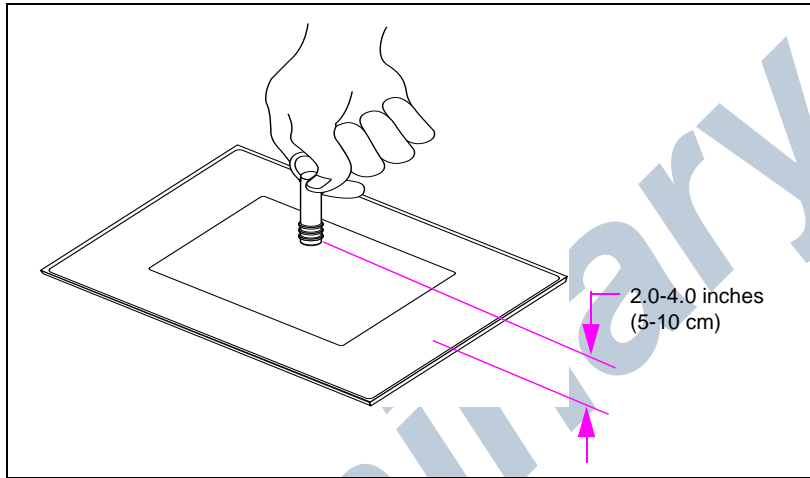

- 6 Go to [“Commissioning and Warranty Information”](#) on page 33.

Preliminary
05/16/02

High Frequency Mat Reader

Figure: **High Frequency Mat Reader Connections**

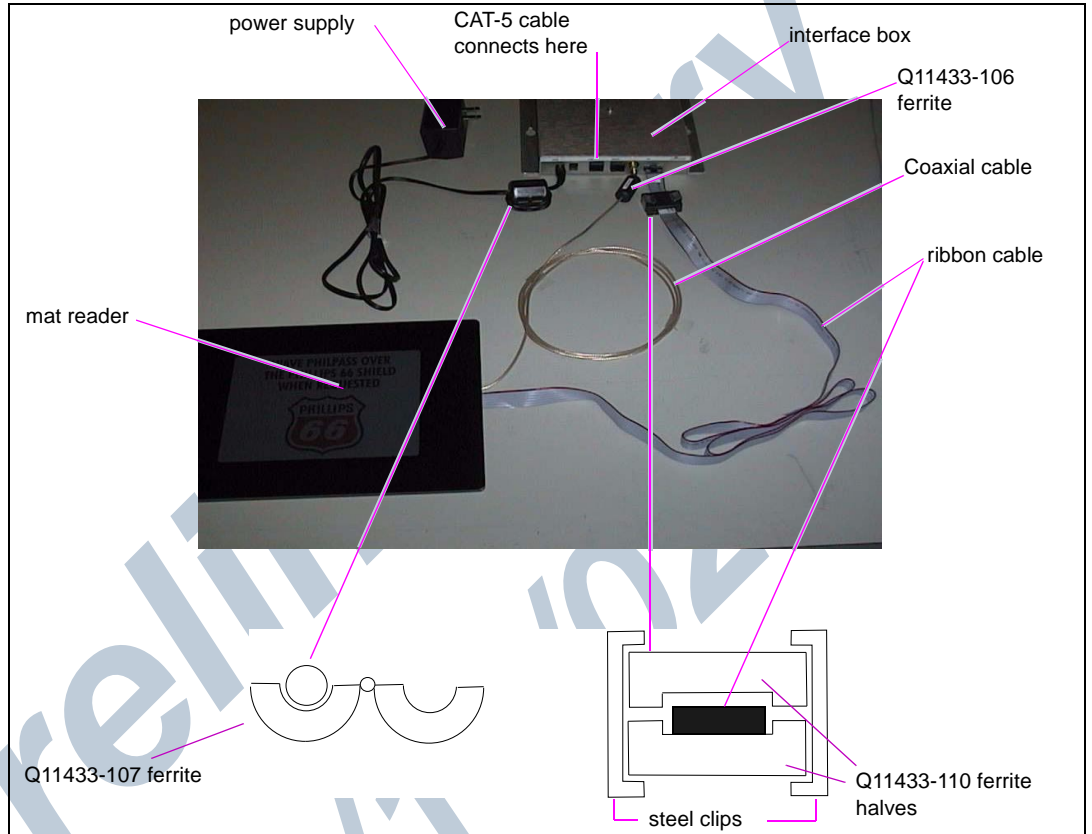

- 1 Install both ferrite halves Q11433-110 on ribbon cable, and secure with steep clips, as shown.

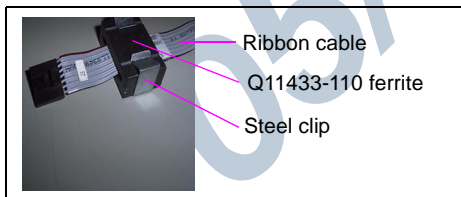

- 2 Be sure clip-on ferrite Q11433-107 is on interface box power supply cable (double loop).

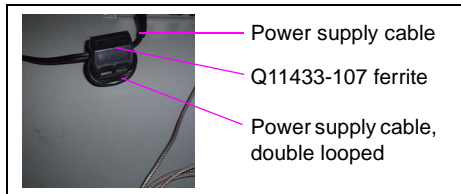

- 3 Install clip-on ferrite (Q11433-106) in pass-through configuration on coaxial cable at Interface Box connection.

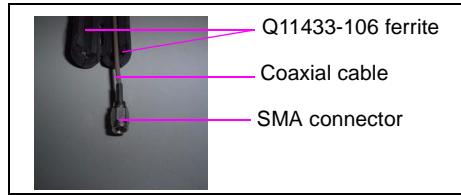

- 4 Dress all cables and secure with stick on cable clamps (Q13459-01).
- 5 Install M01868A002 UL/FCC decal, as appropriate, as shown in [“Figure: Mat Reader Interface Box Mounting Holes”](#) on page 17.
- 6 Clean up the work area.
- 7 Verify the keytag can be read by the mat reader within the specified range.

Figure: **High Frequency Mat Reader Read Verification**

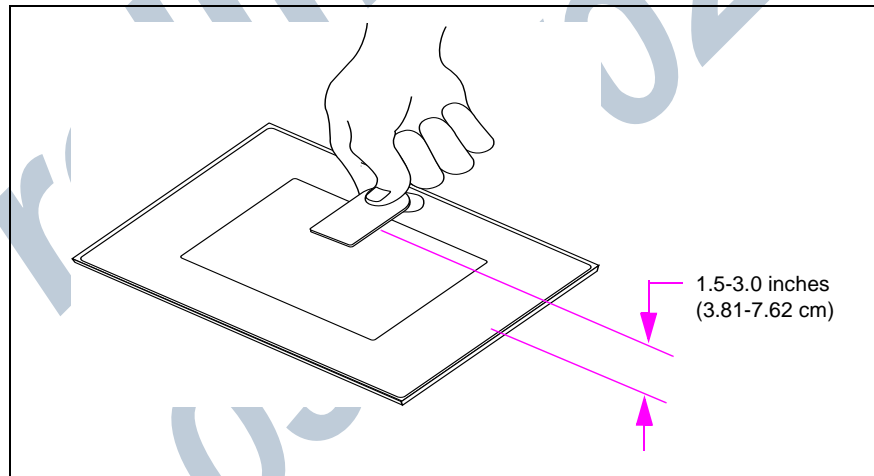

- 8 Go to [“Commissioning and Warranty Information”](#) on page 33.

Commissioning and Warranty Information

Upon completion and testing the Mat Reader system, the installing contractor must call the Gilbarco Call Center at 1-888-800-7498 to register the installation and activate the warranty. Note the installed unit's full Model Number (C00016-XXX) and serial number before making this call.

- All Mat Readers have a one-year parts only warranty.
Note: Parts are to be returned through and obtained from the local Gilbarco distributor.
- Labor warranty, if any, is unit and customer specific.

Gilbarco strongly recommends using only Gilbarco trained ASCs (Authorized Service Contractors) to perform service on the units. Use of non-authorized service personnel to repair or service these units may void warranty. Call your local distributor for service.

Preliminary
05/16/02

Preliminary
05/16/02

G-SITE® and Gilbarco® are registered trademarks of Gilbarco Inc. GOLDSM is a service mark of Gilbarco Inc. Corian® is a registered trademark of E.I. Du Pont De Nemours and Company. Formica® is a registered trademark of Formica Corporation IC® is a registered trademark of Industry Canada. Phillips® is a registered trademark of Phillips Screw Company. UL® is a registered trademark of Underwriters' Laboratories, Inc. Zircon® is a registered trademark of Zircon International Inc.

GILBARCO
VEEDER-ROOT

© 2002 Gilbarco Inc.
7300 West Friendly Avenue • Post Office Box 22087
Greensboro, North Carolina 27420
Phone (336) 547-5000 • <http://www.gilbarco.com> • Printed in the U.S.A.
MDE-4017B Mat Reader Assembly Kit C00016-XXX Installation Manual • May 2002