

Marconi

Installation

TRIND™ Transmitter/Receiver in Dispenser Retrofit Kits C00011-002-XXXX Using TIRIS™ Technology

Introduction

Purpose of this Manual

This manual provides instruction for installing TRIND™/TIRIS™ Retrofit Kits C00011-002-XXXX in The Advantage® Series wide frame units with InfoScreen®, monochrome CRIND™, or single-line CRIND.

The TRIND option allows customers to automatically authorize CRIND-equipped units, using either a hand-held or auto-mounted transponder provided by a major oil company (MOC). Use these kits for one- or two-sided units.

Retrofit Kits C00011-002-XXXX are configured according to specific unit requirements.

Prerequisites

Before installing any TRIND kit, ensure that the existing CRIND contains the following.

- Z-180 logic board and software (T17764-XX), which is not configured in TRIND retrofit kit. Refer to MDE-2628, Cash Acceptor Retrofit Assemblies for The Advantage Series Units with CRIND Card Reader in Dispenser Kit C00007-002.
- Plastic options doors for single-line/cash acceptor InfoScreen/cash acceptor and monochrome/cash acceptor

Important Notice

This equipment has been tested and found to comply with the limits for a Class A digital device pursuant to Part 15 of the FCC Rules. These limits are designed to provide reasonable protection against harmful interference when the equipment is operated in a commercial environment. This equipment generates, uses and can radiate radio frequency energy, and if not installed and used in accordance with the instruction manual, may cause harmful interference to radio communications. Operation of this equipment in a residential area is likely to cause harmful interference in which case the user will be required to correct the interference at his own expense. Changes or modifications not expressly approved by the manufacturer could void the user's authority to operate this equipment.

Required Reading

Before installing the equipment, the installer must read, understand, and follow:

- this manual
- NFPA 30A, The Automotive and Marine Service Station Code
- NFPA 70, The National Electric Code
- applicable federal, state and local codes and regulations
- ASC TRIND Technology Update on page 9

Failure to do so may adversely effect the safe use and operation of the equipment.

Note: These kits must be installed by a Gilbarco ASC (Authorized Service Contractor)

Related Documents

MDE-2531	Pump & Dispenser Start-Up & Service Manual
MDE-2562	CRIND Service Manual
MDE-2628	Cash Acceptor Retrofit Assemblies for The Advantage Series with CRIND
MDE-2620	Graphics Panel Application for The Advantage Series
MDE-3640	Authorized Service Contractor (ASC) TRIND Installation Tool Kit K94577-01
PT-1728	The Advantage Series Illustrated Parts Manual
PT-1736	CRIND Card Reader Illustrated Parts Manual

Required Tools

The following equipment is needed to install TRIND™ kit C00011-002

- Allen wrench set, American standard
- clean cloth or rag
- chip extraction tool, e.g., IC extraction, Digikey Part No. K158-ND or equivalent
- isopropyl alcohol (part# END-1082)
- ladders, style 'A', quantity of two (2)
- multimeter
- pencil or marker
- pliers
- pocket knife
- putty knife or scraper
- Q12534 CRIND diagnostic card
- ratchet set, standard
- screwdrivers, flat and Phillips head
- static guard wrist strap
- straight edge, 24"
- TRIND ASC tool kit (See "ASC TRIND™ Tool Kit K94577-01" on page 3 and refer to MDE-3640, ASC TRIND Installation Tool Kit K94577-01)
- work bench or saw horses (packaging cartons may be used as bench)

PRELIMINARY

Parts Lists

C00011-002-XXXX Kit Configurations by Suffix

-Suffix	Configured For	See
-WF_S	The Advantage® Series 48" (wide frame) single-sided	page 4
-WF_D	The Advantage Series 48" (wide frame) double-sided	page 4

Common Parts for All C00011-002-XXXX Kits

Description	Assembly Contains	Part Number	Quantity
cable clamp, gray		Q13558-04	16
cable clamp, gray		Q13558-06	4
cable group assembly (parts shown in columns at right)		Q13863-01	1
	cable, TRIND to CRIND	R20437-G01	1
	cable, TRIND AC power	R20580-G1	1
	cable, light/multi-protocol	M00857A001	1
	cable, light/multi-protocol	M00857A002	1
	cable, antenna/low frequency	M00878A002	1
card cage assembly		T20606-G1	1
grommet, edge		Q10315-06	1.5 ft.
grommet material, strip		Q10277-02	1 ft.
jump jack		Q11011-01	10
label plate, FCC		N23949-01	1
nut, Keps		Q12068-03	2
screw, sems, 6-32 x 3/8		Q12083-13	1
screw, 8-32 x 3/8		Q12083-26	2
silicone sealant, RTV, tube		END 1576	1
software, CRIND™ Bios TRIND		K93744-01	1
tie wrap		Q10178-01	4
washer, flat		N16599-48	1

ASC TRIND™ Tool Kit K94577-01

Tool Description	Part Number	Quantity
co-axial cable tool	Q13628-01	1
field strength sensor	Q13626-01	1
test tag, TI/RFIDcar mount	Q13630-01	1
test tag, TI/RFID hand held	Q13630-02	1
threaded rod, 3/8-16 x 4"	N23880-01	4
tuning tool, plastic tipped	Q13631-01	1

C00011-002-WF S**For The Advantage® Series 48" (wide frame) single-sided units.**

Kit contains all parts from "Common Parts for All C00011-002-XXXX Kits" on page 3 plus the following.

Description	Part Number	Quantity
antenna assembly	T20632G1	1
bracket assembly, antenna mounting	T20625-01	2
gasket, 1/2" x 1/16" strip	Q11899-12	1.5 ft.
grommet, bulkhead seal	Q13570-01	1
grommet, round	N15941-38	4
load connector, dummy transmitter	R20526-G1	1
option door assembly	T20613-G1	1
screw, 10-32 black	K85736-45	14

C00011-002-WF D**For The Advantage® Series 48" (wide frame) double-sided units.**

Kit contains all parts from "Common Parts for All C00011-002-XXXX Kits" on page 3 plus the following.

Description	Part Number	Quantity
antenna assembly	T20632G1	2
bracket assembly, antenna mounting	T20625-01	2
gasket, 1/2" x 1/16" strip	Q11899-12	3 ft.
grommet, bulkhead seal	Q13570-01	1
grommet, round	N15941-38	4
option door assembly	T20613-G1	2
screw, 10-32 black	K85736-45	16

Safety Information

Alert Symbol and Signal Words



Alert Symbol:

This is a standard ANSI* approved alert symbol. When you see this symbol, be alert to the potential for a personal injury.

* Reference American National Standard Bulletins ANSI Z535.

Signal Words:

These signal words alert you to important safety hazards.

 WARNING	 CAUTION	 DANGER
The hazard or unsafe practice may result in severe injury or death.	The hazard or unsafe practice could result in minor injury.	The hazard or unsafe practice will result in severe injury or death.

Safety Symbols:

The following safety symbols are used throughout this manual to alert you to personal safety hazards and precautions.

-  Explosive
-  Flammable
-  Electrical hazard
-  Use safety barricades
-  No people in area
-  No vehicles in area
-  Use emergency power disconnect
-  No open flames
-  No smoking
-  No power tools
-  Wear eye protection
-  Read all related manuals
-  Clean up spills
-  Turn power off

Before Beginning

Do the following:

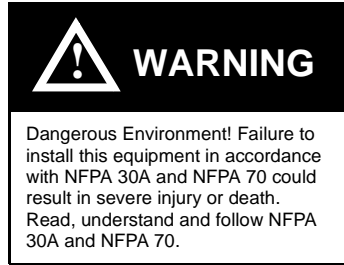

Read all instructions before beginning.

Follow all safety precautions, including:

- Barricade work area.
- Do not allow vehicles or unauthorized people in work area.
- Do not use power tools in work area.
- Do not permit smoking or open flames in work area.
- Wear protective gear while performing this installation.

Record all mechanical and electronic totals.

Turn off all power to unit, unit lights and STPs.

- Use system circuit breakers.
- Multiple disconnects may be required.
- Isolate each pump at distribution box.
- Refer to MDE-2531, Pump and Dispenser Start-up and Service for OSHA lock-out/tag-out procedures.

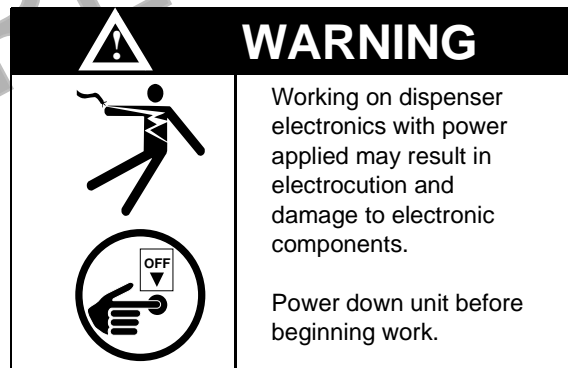

When system battery is present, turn off system battery by pressing CLEAR then ENTER on manager keypad.

Use Electrostatic Discharge Precautions

Place yourself at a neutral static-free potential by doing the following:



- 1 Touch an unpainted metal surface.
- 2 Use a wrist strap connected to a grounded metal frame or chassis.



Note: Failure to use electrostatic discharge precautions may damage electronic components and void warranty.

Make sure all power has been removed from unit and CRIND.

Follow OSHA Lock-Out and Tag-Out Requirements

OSHA Standard 29 CFR 1910-147 Control of Hazardous Energy Sources (Lock-Out/Tag-Out) covers ways to avoid personal injury if power is turned on or fuel pressure is applied unexpectedly while servicing equipment. The rule requires that equipment power and fuel under pressure be turned off and the device (breaker, valve, etc.) locked or labeled with a warning tag.

Read OSHA Standard 29 CFR 1910-147 Control of Hazardous Energy Sources (Lock-Out/Tag-Out). Station employees and service contractors need to understand and comply with this program completely to ensure safety while the equipment is down.

Tag-Out and Lock-Out Procedure

Use plastic warning tags with signature/date blanks for Tag-Out. Sign and date them at shut down. Attach tags with plastic connectors.

Use metal screw-down lock clamps or plastic single or multi-pole devices for Lock-Out of breakers and switches. Always use a lock-out device whenever possible.

When working on electronics and electrical connections (junction box):

- Turn off unit power, light breakers, and all dispensers sharing the same isolation relay box.
- Install lock-out device and tag on breaker(s).

Note: If station does not use STP control wire isolation relays, multiple disconnects may be required to shut off all power supplied to the unit.

Classifying Hazardous Locations

Any activity that can cause an explosion (such as smoking or drilling) must be done well outside the vapor area.

The following diagram is based on NFPA 30A, section 6 and NFPA 70, section 514.

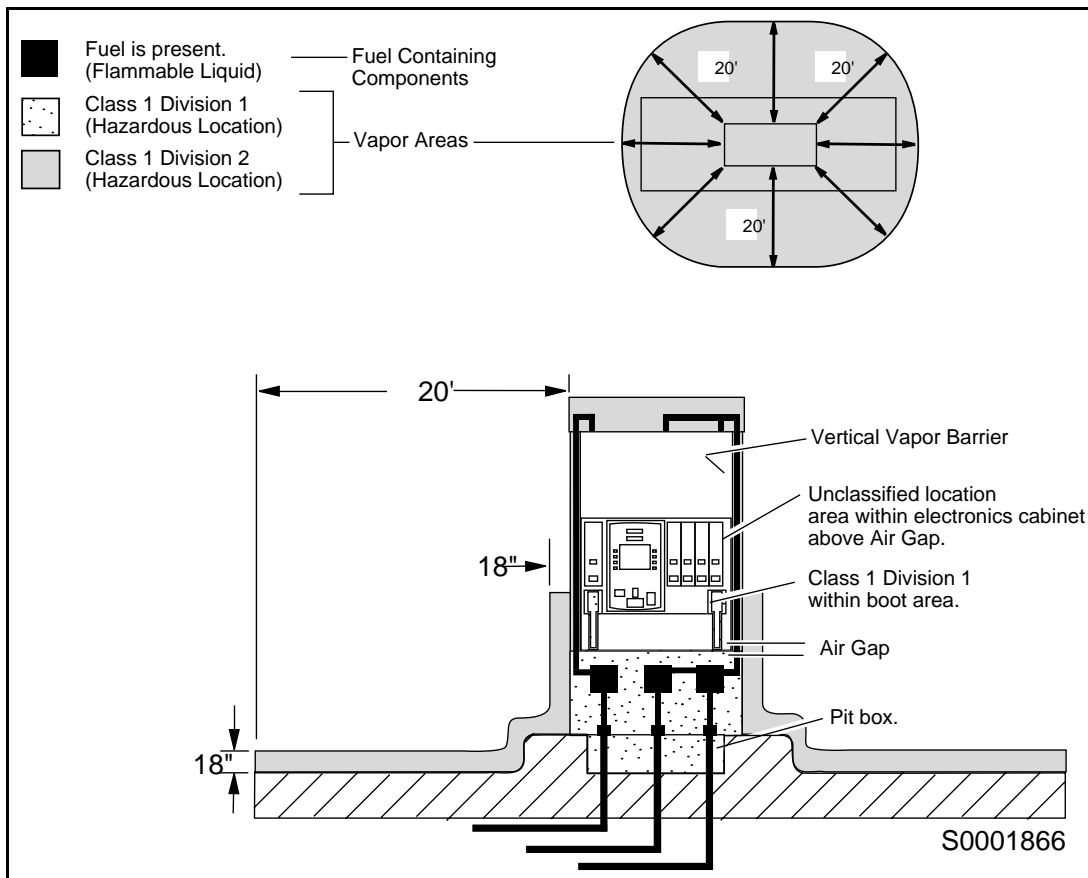

ASC TRIND™ Technology Update

The TRIND™ system utilizes technology and devices not commonly used in the industry. Read the following carefully to familiarize yourself with relatively unique aspects of TRIND and prevent field problems.

RF Transmission and Antennas

Located in the TRIND card cage is a transmitter printed circuit board (PCB). The RF antennas are connected to this board during installation.

Applying power to the card cage with either antenna disconnected will result in damage to the transmitter PCB.

- The transmitter PCB may be burned up immediately, or its effective life shortened drastically.
- The PCB may perform properly at installation, but will require premature field service at a later date.

For single-sided units, a 'dummy load' connector R20526-G1 is provided for unused 'B' side of the PCB.

Note: Power must never be applied to the card cage without a load, either antennas or dummy load connector.

Co-Axial Cable

Co-axial antenna cables Q13756-01, part of cable assembly M00878, used for TRIND are more flexible and smaller diameter than more familiar co-axial cable, such as that used for cable television. However, all co-axial cables share this feature:

Too severe a turn or bend in the cable will break the center (solid) wire.

This can result in a seemingly good but in actuality intermittent signal. This too may result in what appears to be proper performance at installation that is followed by premature failure and field service. Replacing damaged cable in the field is an extensive task.

In addition, a damaged cable will also cause a situation where the transmitter PCB is powered without load, and damage the PCB.

Note: Turns or bends in co-axial cables Q13556-01 must be gradual loops, no sharper than a 1" radius (2" diameter).

For installation instructions, proceed to page 10.

ATTENTION: AUTHORIZED SERVICE CONTRACTORS
READ THIS SECTION BEFORE PROCEEDING WITH INSTALLATION

Installation

Before beginning read “Safety Information” on page 5.

Preparing For Installation

Perform these steps for all The Advantage® Series units

- 1 Remove four hoisting brackets from top of unit by removing four bolts and washers. Dispose of hoisting brackets. Save hardware for reassembly.

Note: On units with logo display cabinet, hoisting brackets have already been removed.

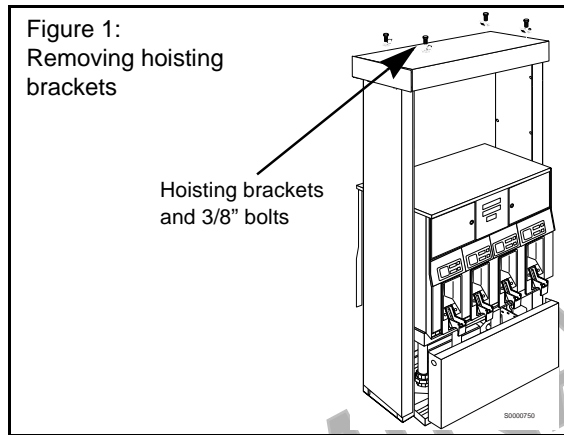

- 2 From ‘A’ side of unit, remove inner sheathing on left column. Set sheathing and screws aside for reassembly.
- 3 Open main access doors. Refer to MDE-2531, Pump and Dispenser Start-Up/Service Manual for access instructions.
- 4 Remove cabinet top cover from main panel by accessing mounting hardware from inside main cabinet. See Figure 2. Save top cover and fastening hardware for reassembly.

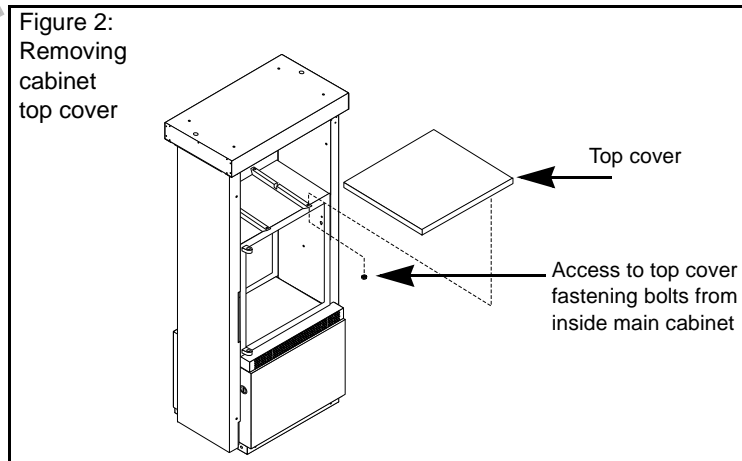

- 5 Remove door mounting pin and right options door. See Figure 3.

Continued →

- 6 Dispose of door. Save pin for reassembly.

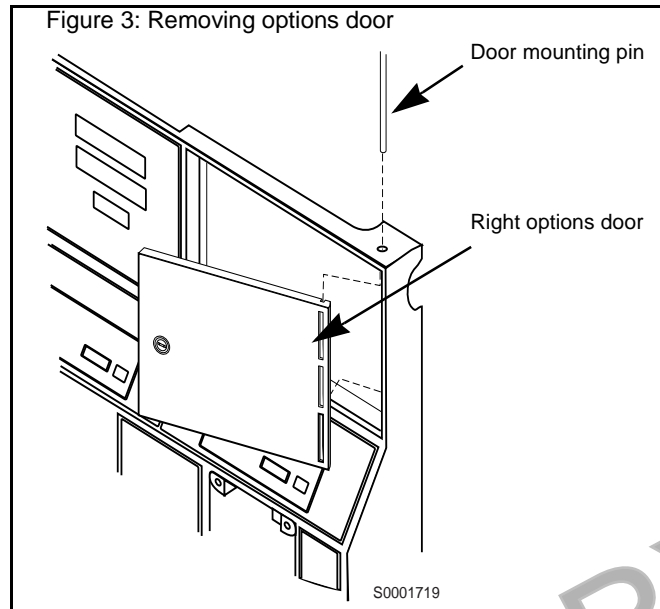

Removing Knockout on Top Cover

- 1 Remove knockout from left side of unit top cover while facing 'B' side for single sided units, or both knockouts for double sided units.
 - For units without end plate, lift left side of top cover for access to knockout from bottom.
 - For units with nine bolt end plates, remove plate for access.
- 2 Lower top cover to original position.
Note: For units with end plate, do not replace plate at this time.
- 3 Install round grommet(s) N15941-38 in hole(s).
- 4 Lower top cover to original position.
Note: For units with end plate, do not replace plate at this time.

Installing Right Options Door

Install new TRIND/TIRIS right options door (one per side for two-sided units), using pin(s) removed and saved in Step 6 on page 11. See “Figure 3: Removing options door” on page 11.

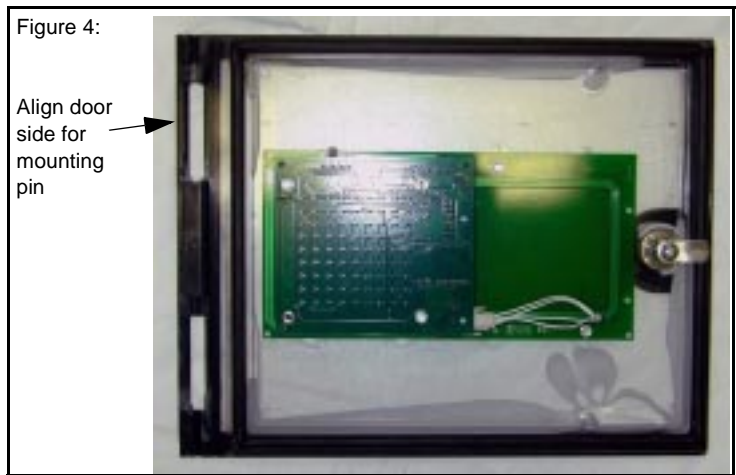

PRELIMINARY

Installing Bulkhead Grommet

- 1 In electronics cabinet, disconnect two cables and remove ground connector to 'A' side printer. Remove printer from unit and save for reinstallation.
- 2 While facing 'A' side of unit, measure 6" in toward center of cabinet top from outside edge of top, and draw a line on top cover. See Figure 5.

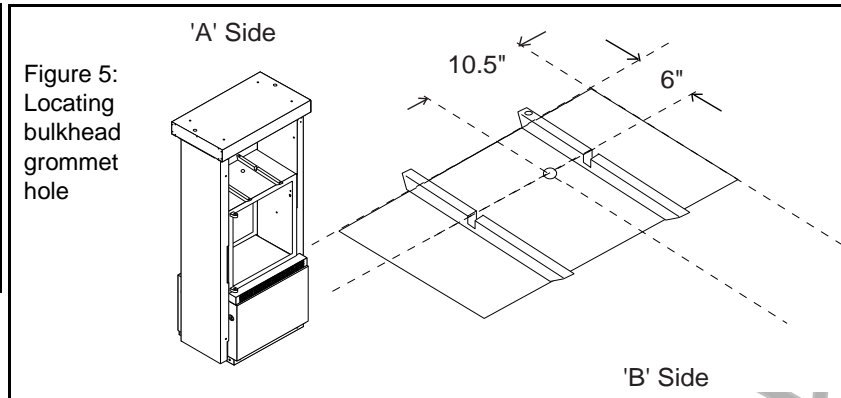

- 3 Measure 10.5" in from left side of top, and draw a line. See Figure 4. Intersection of both lines is pilot hole location.
- 4 In packaging materials, locate thick rubber packing that can be broken into flat sided pieces, approximately six inches round, square or random.
- 5 On one flat side of thick rubber piece, apply light coating of cutting oil.
- 6 With oil coated surfaces in contact with metal surfaces, heavily tape one each foam piece to top and bottom of main cabinet top, above and below drilling point marked. See Figure 6.
Note: For foam piece taped to top, mark foam with marking pen or pencil to identify drilling point under foam. Drilling point location accuracy of plus or minus 1/2" is acceptable.

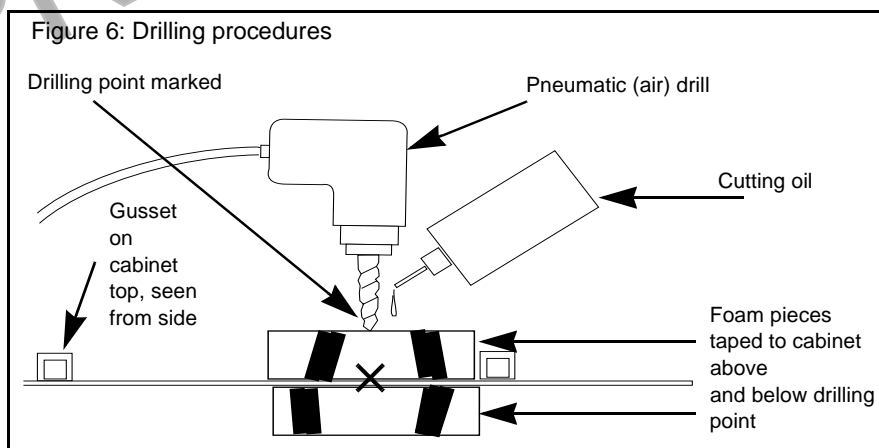

- 7 Cover shelf area under drilling position with plastic. Kit packaging materials may be used.

Continued →



Do not use electric drill

- 8 Follow these mandatory safety guidelines:
- Do not use electric drill. Use only pneumatic (air) drill set or controlled for low speed only (300-500 rpm) or hand operated drill.
 - Deposit a few drops of cutting oil at drilling point and on drill bit, to keep bit from binding, to quench sparks and to bind drill shavings.

- 9 Drill through foam pieces, going only as deep as required to penetrate top cover, beginning with small diameter bit (approximately 1/8") and gradually increasing bit size until adequate pilot hole is made.

Note: Hole 3/8" in diameter should be sufficient as pilot for knockout.

- 10 Remove both top and bottom foam pieces, being careful that all drilling residue and oil is removed from cabinet area. Wipe off cabinet surface, top and bottom, with clean cloth or rag.

Note: Use file or deburring tool to remove burrs or edges that may cut hands.

- 11 Using hydraulic or manual knockout punch, make one inch (1") diameter hole.

- 12 Remove plastic covering hardware by folding inwards to retain any drilling residue, and dispose of plastic.

- 13 Carefully check interior of main cabinet for trash or residue and clean as needed.

- 14 Position bulkhead seal grommet (Q13570-01) with O-ring beneath hole.

- 15 Secure grommet in place with locking nut from top of cabinet.

- 16 From 'A' side of unit, drop (lower) CRIND tray. Refer to MDE-2531.

CAUTION

Edges of drilled holes may have sharp edges or burrs.

Cleaning or working around drilled areas not properly deburred could result in **minor injury**.

PRELIMINARY

Installing Card Cage Assembly

Install card cage assembly from 'B' side of unit according to the following steps:

- 1 Carefully pry out printer cable retainer from underside of printer shelf.
- 2 Pull printer cable out of 2 3/4" round hole from bottom, and install piece of strip grommet Q10277-02 around perimeter of hole.
- 3 For all single-sided units, connect dummy load connector R20526-01 to JB on transmitter PCB. See "Card Cage Assembly T20606-G1" on page 25 for connection point.
- 4 Install card cage assembly fuse side first on printer shelf and against center divider behind right options door, as shown in Figure 7.

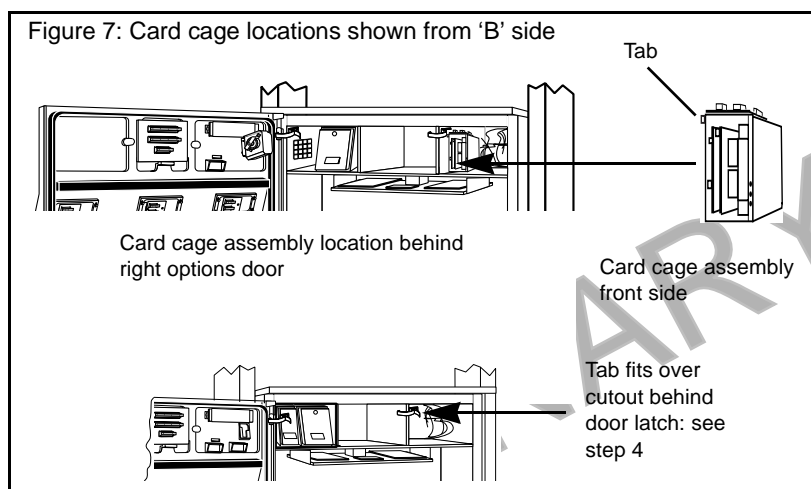

- 5 Position card cage so that tab on upper left side of housing fits over latch cutout for main door latch, securing card cage to divider. See Figure 7.
- 6 From 'B' side of unit, feed screw Q12083-13 and washer N16599-48 up through hole in shelf into threaded hole in card cage bottom.
- 7 Feed three prong female end of power supply cable R20580-G1 up through grommeted hole in printer shelf to recessed receptacle on card cage assembly. Refer to "Card Cage Assembly T20606-G1" on page 25 for connection points.
- 8 Secure power cable R20580-G1 in cable retainer removed in Step 1, so that power cable and printer cable are both secured, and reinstall cable retainer in grommeted hole.
- 9 Feeding cables up through grommeted hole connect P8 (two position, mate and lock) on 'B' side data cable M00857A001 to J8 on data control PCB Q13563 in card cage assembly (two sided units), and connect P7 on 'A' side data cable M00857A002 to J7 on data control PCB Q13563-G4 in card cage assembly (all units).
Note: Caution: do not overtighten cables connectors.
- 10 Return printer to shelf and reconnect two printer cables and ground connector.
- 11 Reorient printer and secure to shelf.
Note: Caution: antennas must be connected to card cage transmitter board whenever power is applied or damage to transmitter board may result.

Installing Transmitter Cables

Note: Sharp bends in antenna cables will cause damage. All cable turns must be in loops and gradual. Refer to "ASC TRIND™ Technology Update" on page 9.

- 1 Feed P1A and B and P3A and B ends of M00878A001 cable assembly (harness) up through bulkhead grommet in main cabinet.
- 2 Be sure that there is sufficient length (24") of cable assembly remaining in electronics cabinet to reach connection points on card cage. Cable ends must be routed through underside of card cage to connection points on 'B' side. See "Card Cage Assembly T20606-G1" on page 25 for connection points.
- 3 Lay M00878 cables flat across top of main cabinet, through gusset opening to column as shown in Figure 8.

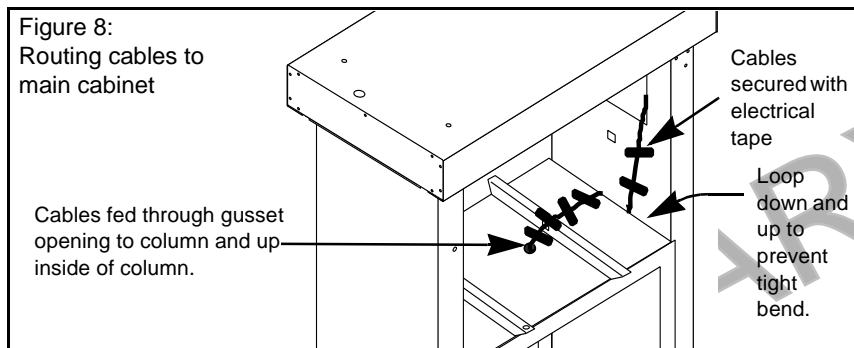

- 4 Use electrical tape to secure cables flat to top of cabinet and in gusset opening. See Figure 8.
- 5 Route M00878 cables from top of main cabinet up along inside of column, keeping cables flat and parallel. See Figures 7 on page 16 and Figure 9 on page 17.
- 6 Loop cables 3" down into space between column and main cabinet and back up again to allow for reinstallation of inside sheathing. See Figures 8 on page 16 and Figure 10 on page 17.
Note: Turn in cables must be gradual, not sharp, to prevent damage to cables.
- 7 Feed cable connector P1A and B and P3A and B ends up through grommet in unit top cover and leave cable ends there.
- 8 Without removing top sheathing, install piece of strip grommet Q10315-06 along edge of top sheathing where cables pass in column. See exploded view in Figure 9.
Note: Carefully check for any points where cables are run where cables may come in contact with sheet metal edges, and install edge grommet to prevent cable damage.

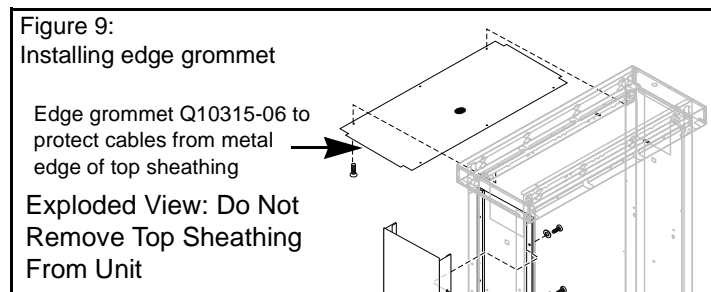

Continued →

- 9 Lay cables flat and parallel to column and secure with electric tape as shown in Figure 10.

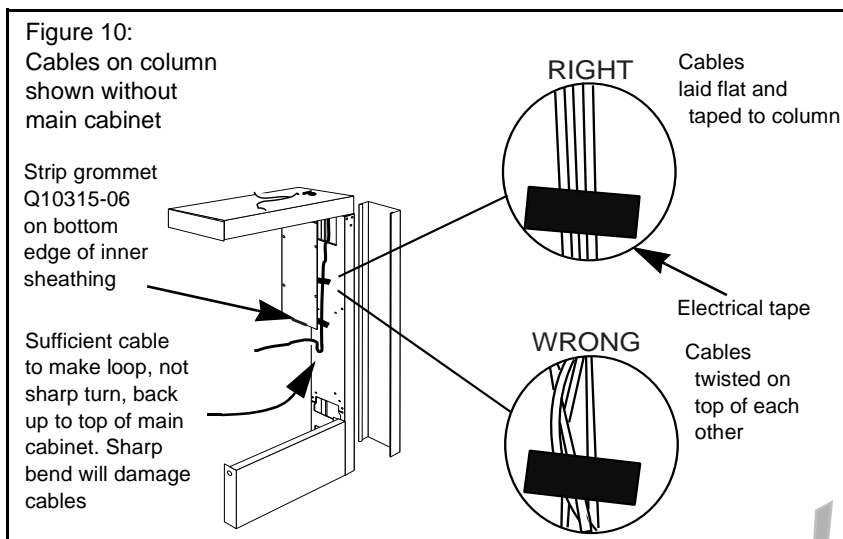

- 10 Install edge grommet Q10315-06 on bottom edge of inner sheathing (see Figure 10), and replace inner sheathing, using screws saved during disassembly.

PRELIMINARY

Installing Overhead Antenna and Brackets

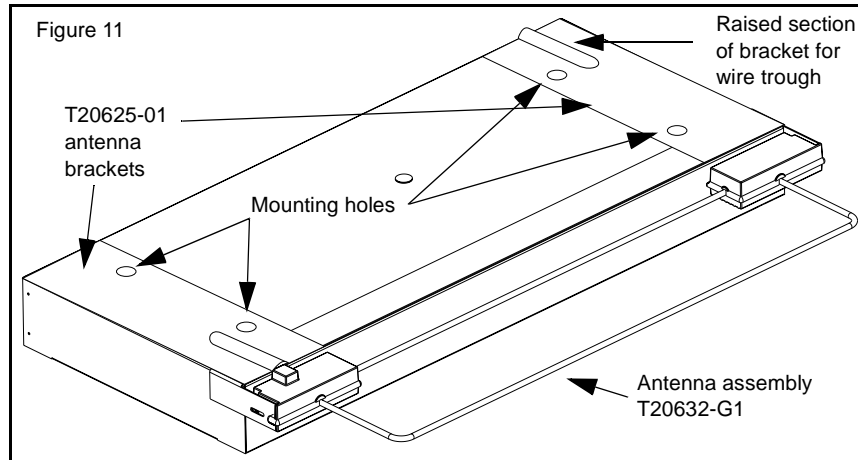

Locate mounting brackets in T20625-01 assemblies and do the following:

- 1 Position one each mounting bracket at each short side of unit, for either single or double sided units.
- 2 Align mounting holes in brackets with holes for hoisting brackets.
- 3 Loosely secure brackets using one bolt (for each bracket) removed and saved in Step 1 of “Preparing For Installation” on page 10. Utilize bracket hole furthest from antenna assembly, to allow for lifting of end of bracket and wire access. Do not tighten bolt at this time.
- 4 Using hardware supplied with antenna assembly fasten antenna assembly T20632-G1 (one per side for two sided units) to antenna bracket(s) T20625-01.
- 5 Lifting side of antenna and bracket assembly, connect P1 and P3 cable connectors for each side according to table on page 23.
- 6 With connections made, feed connectors back down into upper housing through grommet.
Note: Sufficient lead is provided on antenna wire assemblies to accomplish this.
- 7 Assure that wire leads remaining on top cover fit under raised portion of antenna brackets when brackets are lowered, and securely fasten antenna bracket(s) to unit top using all hardware removed and saved in Step 1 of “Preparing For Installation” on page 10.

Modifying Cabinet Top Cover

- 1 Use hacksaw to cut 3/8" slots in cabinet top cover to allow strip a minimum of 6" wide to be folded back with pliers and hammered flat as shown in Figure 10, to allow cables to pass under top cover to grommet.

Note: Remove top cover from work area to cut slot. Do not cut metal in proximity to dispensers. Place top cover on cardboard while hammering to prevent damage to paint.

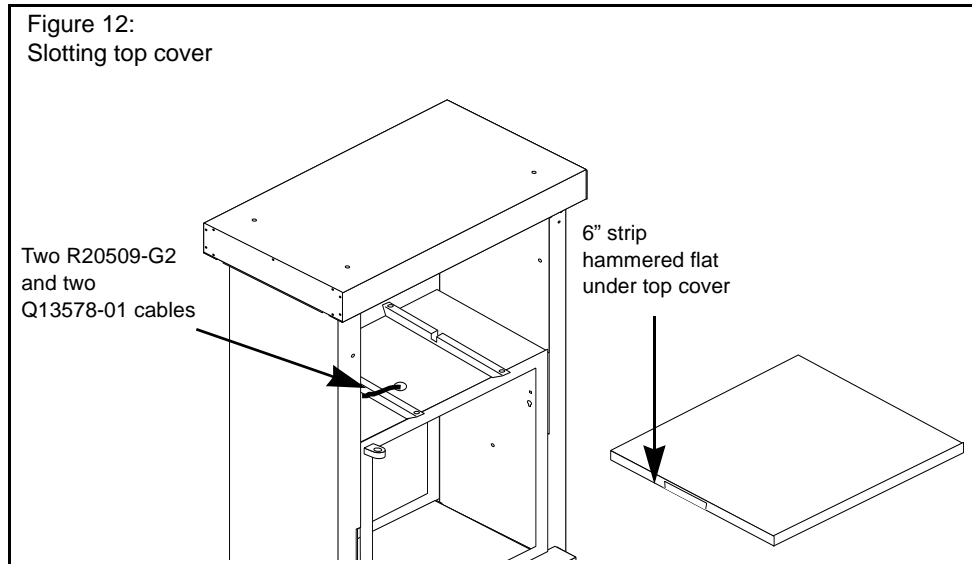

- 2 Clean edges and burrs around cuts in cover with file or deburring tool.
- 3 Thoroughly seal spaces around and between cables in main cabinet bulkhead grommet with RTV sealant supplied with kit.
Note: Place some packaging plastic inside bulkhead grommet from top to prevent sealant from running out bottom when applied.
- 4 For units with upper housing end plates, replace end plate using nine screws removed and saved with plate.

Routing Cables

Retrofit kit comes with twenty (20) cable clamps, four large (Q13558-06) and sixteen small (Q13558-08). Number required for proper installation varies with units. Large clamps are for use with power cable R20580-G1.

Note these variations for routing cable to card cage:

Horse Shoe style CRIND™

For these units, utilize opening in printer shelf bottom for routing.

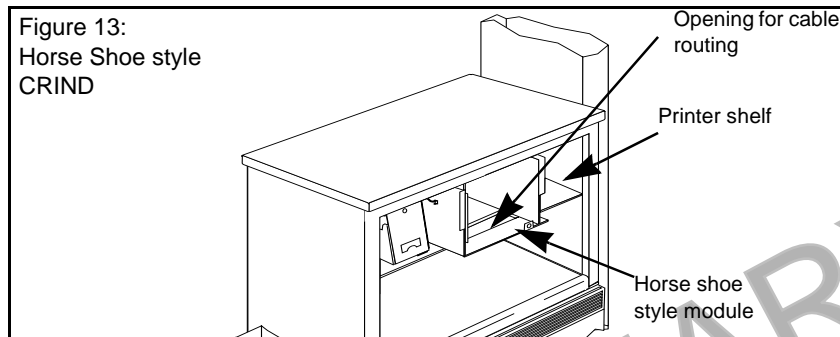

Pull Out CRIND Tray

For these units utilize round 2-3/4" hole in printer shelf bottom, used for printer cable. Use cable clamps to secure cables to underside of printer shelf.

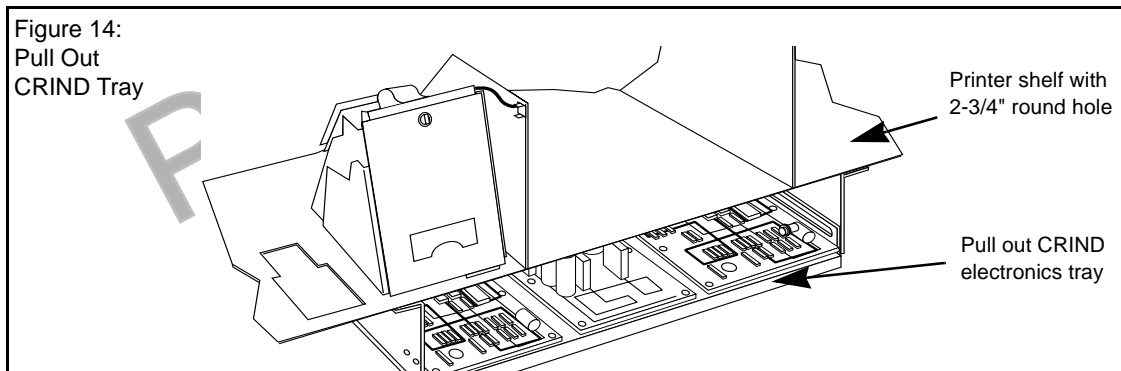

Continued →

Cable Routing to Option Doors

When routing door cables to card cage, leave excess cable on door, routing cable around edges of printed circuit board.

Note: It is critical that door cables do not get crimped or pulled when either options door or main door are opened or closed. Be sure that door cables are secured such that they cannot be caught in main door when door is closed, and always close main door before options door.

- Remove option door shield
- Assuring sufficient cable to reach connection points on card cage, use clamps to secure cables to underside of lighting frame. Be sure clamps are secured to non-removable part of frame, so access is maintained for lighting service.
- Route door cables around door electronics and connect cables. See “Connecting Cables” on page 23.
- Loosely secure cables using tie wrap Q10178-01 and hole on light-microreader printed circuit board.

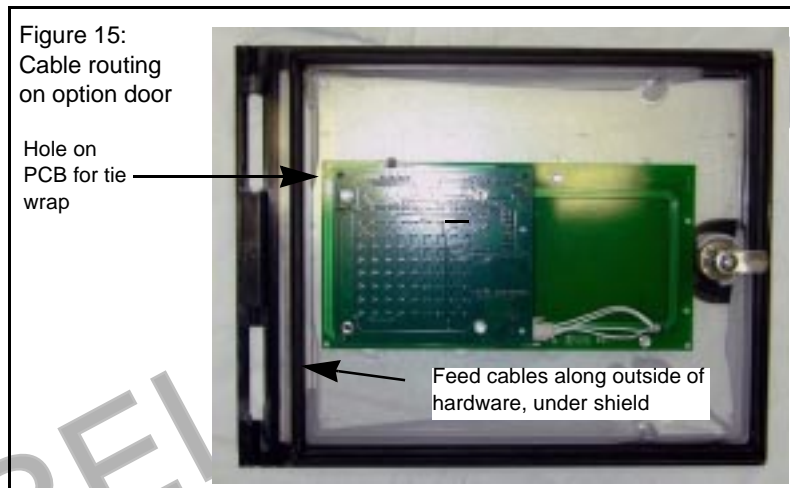

- Being sure that option door opens and closes freely without stressing or crimping cables, use tie wrap Q10178-01 to loosely secure cables to small fixed tab at end of light frame, forcing cables between light frame and door gasket.

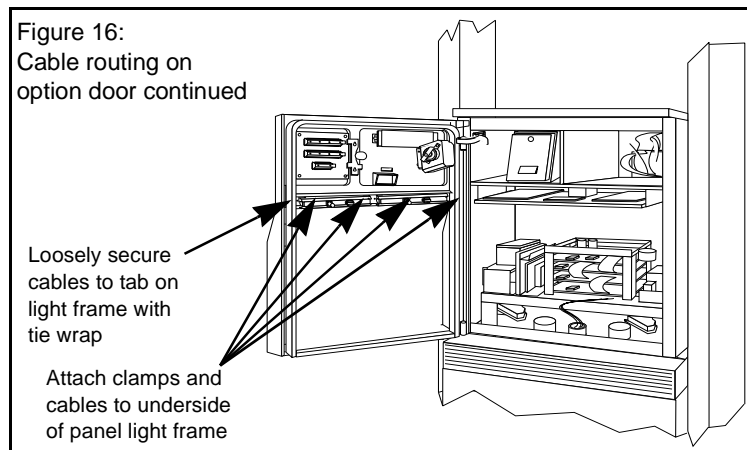

Continued →

Cable Routing to Main Cabinet

When routing cables from main door to cabinet, be sure to allow sufficient slack in cables to allow main door to open and close freely, without pulling on or crimping cables.

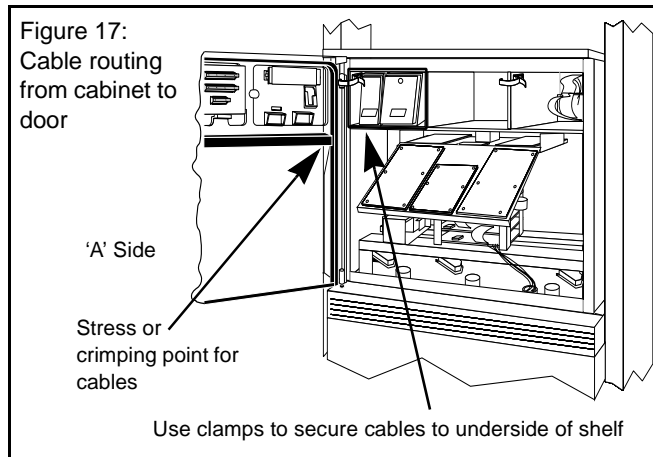

Feed cables through 2-3/4" round hole after installing Q10277-02 strip grommet on perimeter.

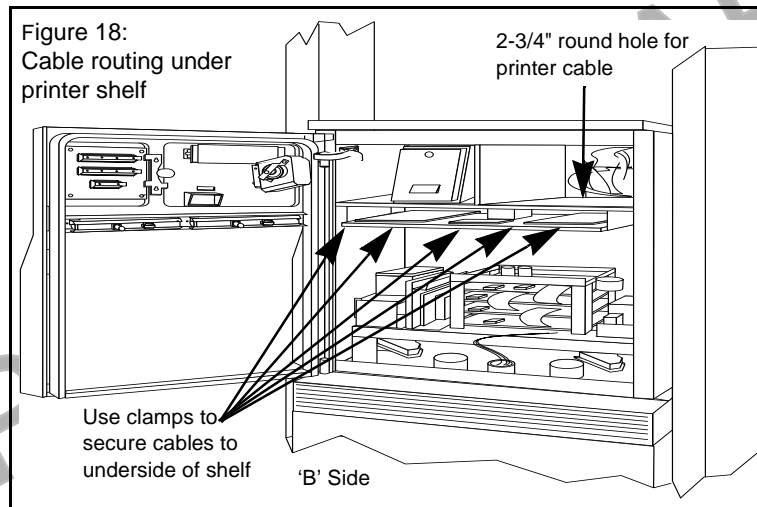

Connecting Cables

Cable connections for The Advantage Series.

For exploded view of card cage assembly and location of connection points, see “Card Cage Assembly T20606-G1” on page 25.

For all single-sided units, install dummy load connector R20526-01 on JB on transmitter PCB and skip all ‘B’ side connections.

Note: If power is applied to card cage without antenna cables or dummy load connected the transmitter board will be damaged.

On Cable	Connect	To	On
M00878A002	PA	JA	Low Frequency Transmitter Board Q13579-01
	PB	JB	
	P2A	J2A	Ultra High Frequency (UHF) Receiver Board Q13564 (Part of Q13564-04)
	P2B	J2B	
	P1A	J1A	Low Frequency Overhead Antenna (A side)
	P3A	J3A	UHF Receive Antenna (A side)
	P1B	J1B	Low Frequency Overhead Antenna (B side)
	P3B	J3B	UHF Receive Antenna (B side)
M00857A001 A side	P7	J7	Data Control Board (DCB) Q13564-04
	J177	P177	Power Supply Board T20314-G1
	JA	PA	R20724-G1 Cable (from Gateway PCB)
	J182	P182	Light/Microreader Board T20601-G1
M00857A002 B side	P8	J8	Data Control Board (DCB) Q13564-04
	J176	P176	Power Supply Board T20314-G1
	JA	PA	R20724-G1 Cable (from Gateway PCB)
	J182	P182	Light/Microreader Board T20601-G1
R20437-G01	J250	P250	Gateway Board T20128-G3
	J258A	P258	CRIND Logic Board T17764-GX (A side electronics)
	J258B	P258	CRIND Logic Board T17764-GX (B side electronics)
R20580-G1	AC Power	P3	Rear of card cage assembly T20606-G1
	P708	J708	AC distribution cable T19612-GX (on A side)

*Note: * indicates connection point is on card cage assembly.*

Note: Route cables R20521-G1 and -G2 and R20437-G01 through bottom of card cage to ‘B’ side for connections.

Connections for power supply cable R20580-01 are unit specific. With three prong female end already in rear of card cage, use appropriate connector to intercept power on existing unit power cable by installing R20580-01 in-line.

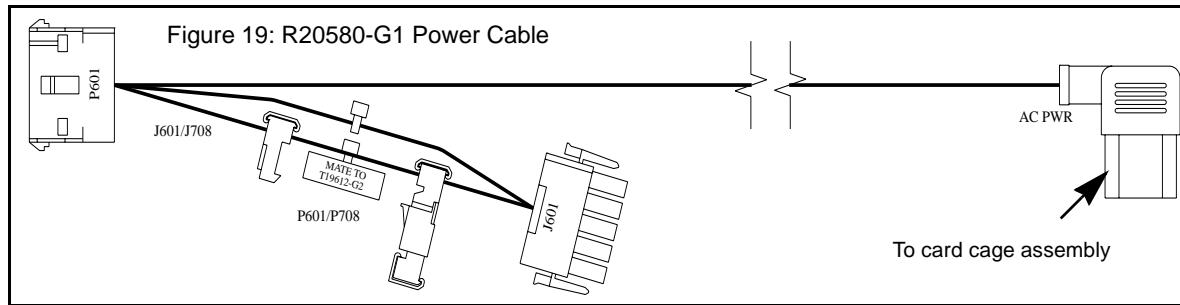

PRELIMINARY

Card Cage Assembly T20606-G1

Figure 20:
Card cage exploded

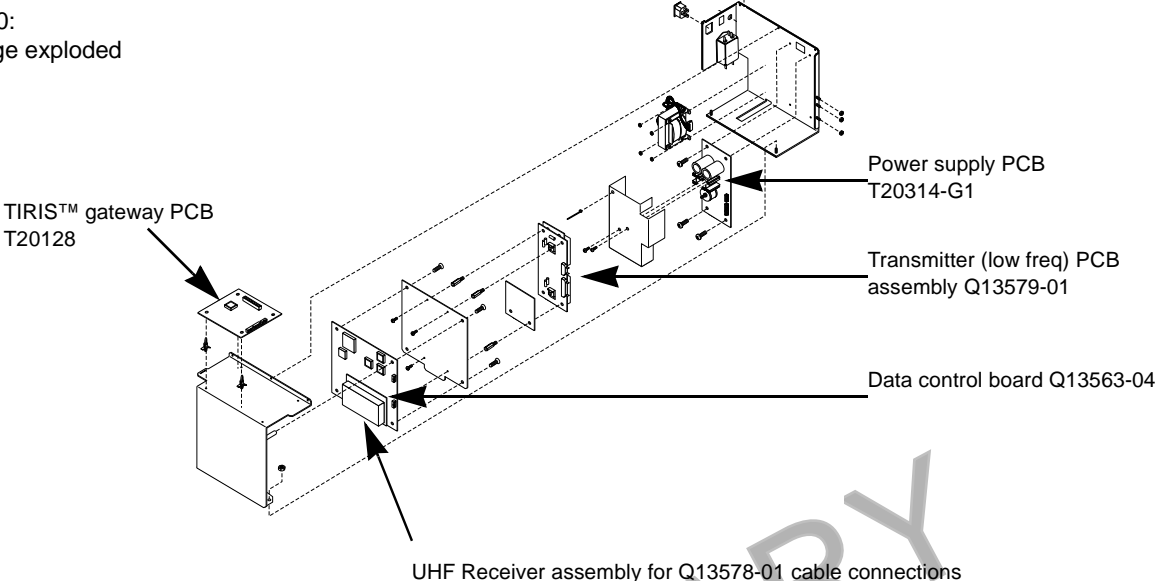
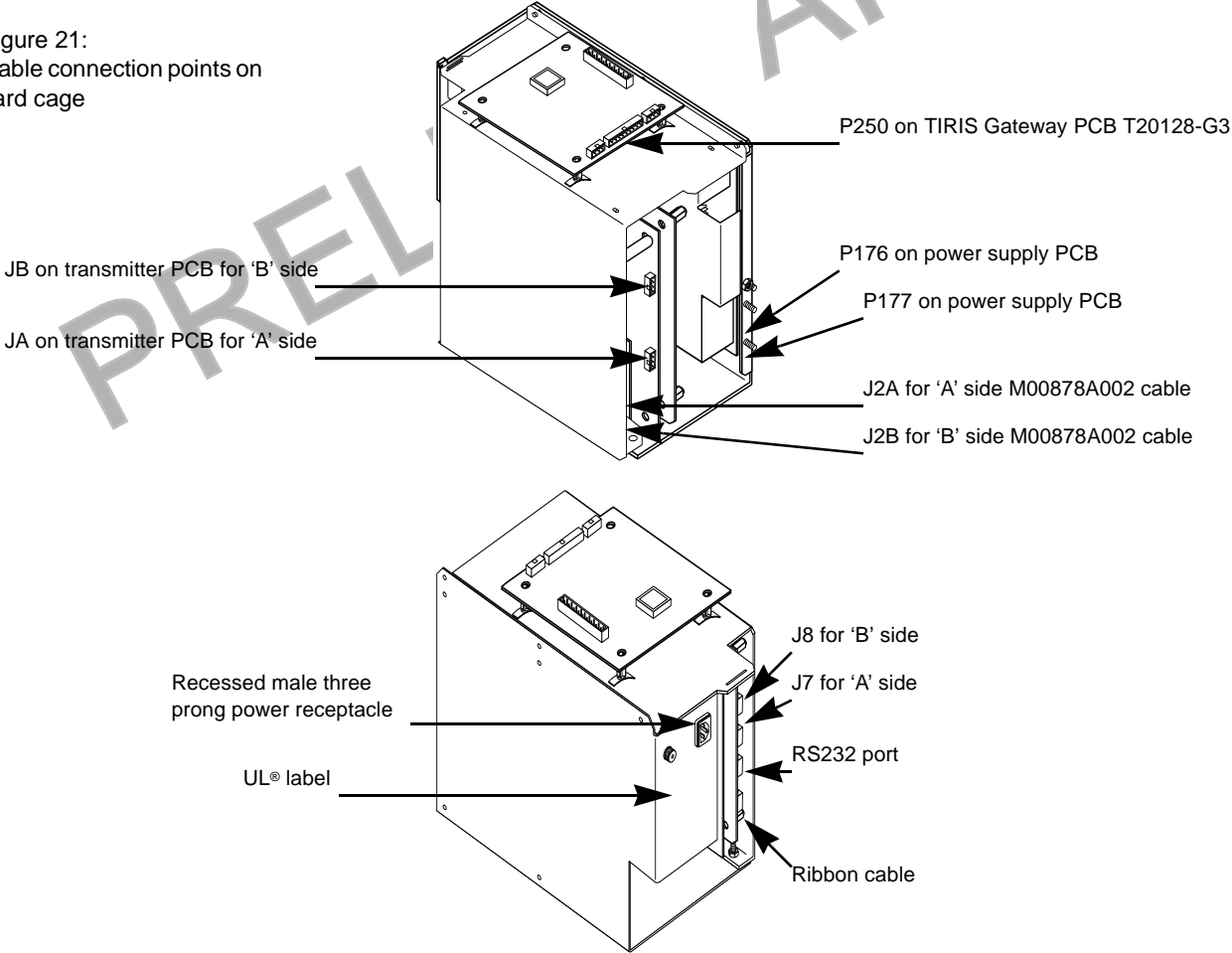

Figure 21:
Cable connection points on
card cage



CRIND™ BIOS TRIND™ Upgrade

Units must have current Z-180 CRIND logic board. Refer to MDE-2628, Cash Acceptor Retrofit Assemblies for The Advantage® Series Units with CRIND Card Reader in Dispenser.

Install the CRIND Bios TRIND software (K93744-01), one per side, on the T17764-XX CRIND logic board(s) according to the following steps.

Note: A properly grounded electrostatic discharge wrist strap must be worn during this procedure.

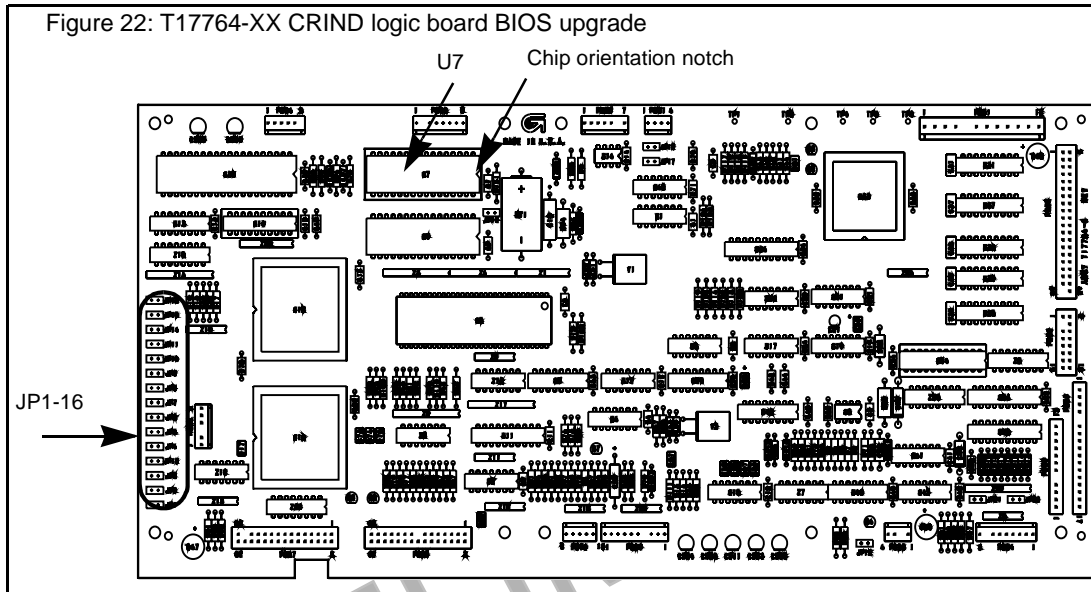

- 1 Locate and remove existing BIOS at U7 using a grounded chip removal tool.

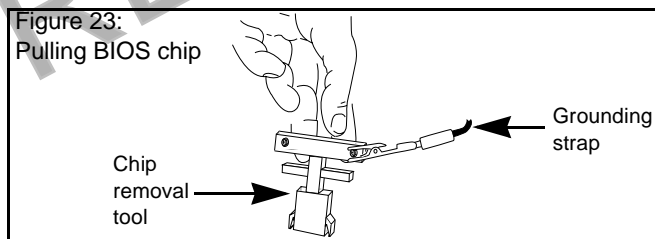

- 2 Install TRIND BIOS K93744-01 (one per side) at position U7, orienting notch on chip with indication mark on board as shown in Figure 22.
- 3 For The Advantage® Series units with CRIND tray, restore CRIND tray to operating position.

Dispenser Set-Up

Addressing Dispenser

Each dispenser on the G-Site controller must be addressed differently; no two dispensers may have the same address. Address is at discretion of the installer. Follow these steps:

- 1 From A side of unit, locate dip switches on power supply board (PCB) T20314-G1 in card cage.
- 2 Using switches 2, 3, 4 and 5 address each dispenser according to the following table:
Note: Switch one in down position is standalone mode selected, used for service only.



Addressing Gateway Board

Address for TRIND™ must match address on CRIND™ logic board. Follow these steps for each side of unit:

- 1 Locate CRIND logic board T17764-XX.
- 2 Note position of jump jacks and set jump jacks on Gateway board T20128 to match address on CRIND logic board.

Note: For double-sided units set address for both A and B sides.

MOC and Generic CRIND Addresses.

Address On CRIND Logic Board T17764-XX	JP8	JP7	JP6	JP5	JP4
= Address on Gateway Board T20128 'A' Side	JP6	JP7	JP8	JP9	JP10
= Address on Gateway Board T20128 'B' Side	JP14	JP15	JP16	JP17	JP18
1	IN	OUT	OUT	OUT	OUT
2	OUT	IN	OUT	OUT	OUT
3	IN	IN	OUT	OUT	OUT
4	OUT	OUT	IN	OUT	OUT
5	IN	OUT	IN	OUT	OUT
6	OUT	IN	IN	OUT	OUT
7	IN	IN	IN	OUT	OUT
8	OUT	OUT	OUT	IN	OUT
9	IN	OUT	OUT	IN	OUT
10	OUT	IN	OUT	IN	OUT
11	IN	IN	OUT	IN	OUT
12	OUT	OUT	IN	IN	OUT
13	IN	OUT	IN	IN	OUT
14	OUT	IN	IN	IN	OUT
15	IN	IN	IN	IN	OUT
16	OUT	OUT	OUT	OUT	IN
17	IN	OUT	OUT	OUT	IN
18	OUT	IN	OUT	OUT	IN
19	IN	IN	OUT	OUT	IN
20	OUT	OUT	IN	OUT	IN
21	IN	OUT	IN	OUT	IN
22	OUT	IN	IN	OUT	IN
23	IN	IN	IN	OUT	IN
24	OUT	OUT	OUT	IN	IN
25	IN	OUT	OUT	IN	IN
26	OUT	IN	OUT	IN	IN
27	IN	IN	OUT	IN	IN
28	OUT	OUT	IN	IN	IN
29	IN	OUT	IN	IN	IN
30	OUT	IN	IN	IN	IN
31	IN	IN	IN	IN	IN
32	OUT	OUT	OUT	OUT	OUT

Preparation for Tuning Antennas

Antenna tuning requires use of field strength sensor Q13626-01 supplied with ASC tool kit.

- 1 For units without G-Site™ put unit in 'Stand Alone' mode by disconnecting J4 on the DCB board and placing jumper on light microreader board at JP3.

Note: JP3 and J4 can never both be in or both out. One and only one must always be in, the other out.

- 2 Restore power to unit(s) and cold start the CRIND. Refer to MDE-2562, CRIND Service Manual for detailed instructions.

Note: Be sure transmitter cables are connected before restoring power.

- 3 Once the CRIND display indicates unit is downloading, remove the Cold Start jump jack.

Tuning Antennas

Do the following for each side:

- 1 Locate tuning pot access hole on underside of antenna enclosure. Pot has slot for tuning tool.

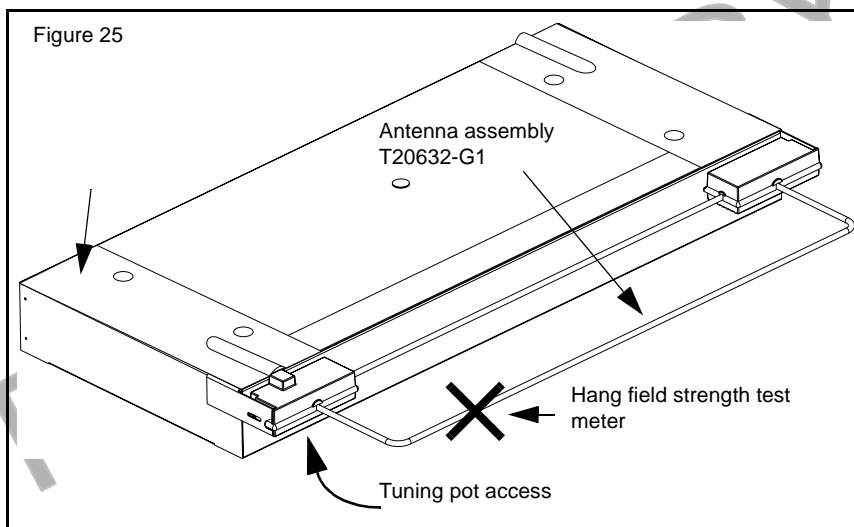

- 2 Tuning pot in overhead antenna enclosure should be turned out 5 to 6 turns.

Note: Use tuning tool Q13631-01 from the ASC TRIND tool kit to make pot adjustments. Refer to MDE-3640 ASC TRIND Tool Kit for instructions.

- 3 Hang field strength sensor in position shown on overhead antenna, to right of antenna enclosure. See Figure 25.

Continued →

- 4 On card cage, move three position 'tune' toggle switch from center position to 'A'. See Figure 26.

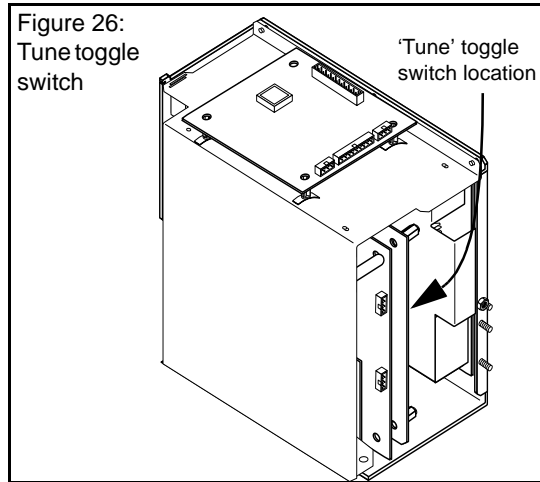

- 5 Connect leads on multi-meter set to DC voltage to field strength sensor.
- 6 By fine adjustments to tuning pot, set to highest DC voltage reading.
Note: Voltage will peak at a point, and then decrease with turns in either direction. Set at peak.
- 7 After completing steps for all sides return tune toggle switch to center position.

PRELIMINARY

Testing TRIND™

- 1 From 'A' side of unit touch hand held test tag (Q13630-02 from the ACS TRIND tool kit) to TRIND target graphic. Door or faceplate TRIND indicator will light.
Note: If indicator fails to light check whether light on other side is on; if so it indicates a crossing of 'A' and 'B' side cables. Check connections.
- 2 From 'A' side of unit hold car mount test tag (Q13630-01 from the ASC TRIND tool kit) in front of unit, at a distance of approximately 6 feet from overhead antenna. Door or faceplate TRIND indicator will light.
- 3 Repeat Steps 1 through 3 for 'B' side.

Alternative Testing Using Laptop

- 1 Connect laptop to RS232 port on DCB.
- 2 Go to:
 - Windows program
 - Accessories
 - Terminal
 - Settings
 - Communications
- 3 Set for:
 - 9600 baud
 - 8 bit
 - No parity
 - Comm 1
- 4 Then go to:
 - Help screen
 - Antenna scan
 - Choose 1, 2, 3 and 4*Note: This will test both antennas*
- 5 From 'A' side of unit touch hand held test tag (Q13630-02 from the ACS TRIND tool kit) to front of TRIND target graphic. Door or faceplate TRIND indicator will light.
- 6 From 'A' side of unit hold car mount test tag (Q13630-01 from the ASC TRIND tool kit) in front of unit, at a distance of approximately 6 feet from overhead antenna. Door or faceplate TRIND indicator will light.
- 7 Repeat Steps 5 and 6 for 'B' side.

Setting Baud Rate

For major oil company (MOC) TRIND™ installations there is no requirement to set or change baud rate.

Installing FCC Label Plate

For all units install FCC label plate N23949-01 according to the following:

Note: Label on plate is identified as N23949-01 on lower left corner of label.

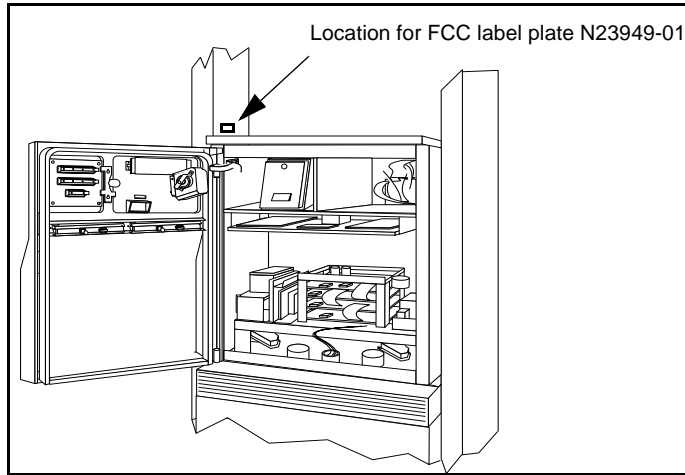

- 1 Peel paper backing off FCC nameplate N23949-01 to expose adhesive on back of plate.
- 2 From A side of unit, affix FCC label plate to left side inner sheathing, above main cabinet top cover.
- 3 Press nameplate firmly in place to secure adhesive bond.

PRELIMINARY